

Features

- DVD SoC with Digital Front-End
- MVP™ Progressive Scan Video Output
- Supports: DVD-Video, DVD-RW, DVD+RW, CVD, SuperVCD, VideoCD, DVCD, Audio CD, Kodak PictureCD™
- Dolby Digital™, Pro Logic™, Pro Logic II™, DTS™, MPEG 5.1, HDCD™, WMA™ Audio Decoding
- ZoranZoom™ and Panning
- Image Enhancement: Sharpness and Brightness Adjustments
- 6-Channel and S/PDIF Audio Outputs
- Virtual Surround Sound, 3D Headphones, Music Modes
- Enhanced Karaoke
- Flexible Support for OPU's and Mechanisms
- Embedded NTSC/PAL Encoder w/four 10-bit Video DACs
- CPPM/CPRM Decryption
- Software Compatible with Vaddis Family
- Turbo 186 CPU
- On-Screen Display (OSD) Processor with 32 Colors and 8 Blending Levels
- Interfaces for Front Panel and IR Remote I/O
- External Flash/ROM/Peripheral Interfaces
- Supports 32-, 64- and 128-Mbit SDRAM Configurations
- 208-pin PQFP Package
- 1.6 W Power Consumption in Full Operation

Benefits Overview

The ZR36768 Vaddis 6E is targeted at entry-level DVD and convergence products. The Vaddis 6E is built upon the Vaddis 5E (integrated Turbo 186 CPU, video and audio decoder) and integrates the main DVD front-end components (servo, read-channel). This integration further reduces the system cost by component reduction and minimizing PCB size. The ZR36768 includes high quality progressive scan analog video output, support for DVD-RW and DVD+RW playback, and WMA decoding. The front-end component integration combined with the CPU and superior back-end functionality makes the ZR36768 the ideal choice for DVD standalone players, DVD-receivers, DVD+VCR combos, DVD+TV combos, DVD mini-component and portable systems.

DIGITAL FRONT-END ARCHITECTURE

The Vaddis 6E includes fully-digital front-end processing. The main components of this front-end are the read-channel for data retrieval (through an RF amplifier) from the optical pick-up unit (OPU) and the servo, which enables precise tracking of the optical media. This architecture allows for flexibility in choice of OPU's and mechanisms. It also allows for high performance in error handling of scratched and fingerprinted media.

Feature Description**STREAM PARSING**

The Vaddis 6E can process disc sectors of the disc types listed previously. The bitstreams from these sectors are typically separated into video and audio for further processing, although other data types can be supported (e.g. VMGI, VTSI, sub-pictures). Included in this parsing is any necessary authentication and decryption (e.g. CSS, CPPM, CPRM) for DVD-Video, DVD-RW or DVD+RW.

TURBO 186 CPU, FLASH INTERFACE AND GPIOs

The Vaddis 6E contains the same CPU, flash and GPIO interfaces that are found in the Vaddis 5E, allowing for easy migration from Vaddis 5E to Vaddis 6E designs. The Turbo 186 CPU core provides interrupts, DMA & UART services and has an architecture familiar to many. This CPU is superior in performance to a standard 186 processor and supports execution of large programs. The system software is stored on external flash or ROM and is accessed via the flash/ROM interface. Peripherals such as USB controllers can be connected to the flash/ROM interface for open-system designs. The GPIOs can be used to control front panels, including inputs via remote control, or other devices per a system's needs.

MULTI-FUNCTION PLAYER

The Vaddis 6E contains the video and audio processing power to handle playback of all of the disc types listed in "Features". The Vaddis 6E is designed with Zoran's StandardsPlus™ methodology, which means that the device is capable of supporting existing standards with some desirable enhancements including HDCD™, MP3, JPEG and WMA file playback. The programmable nature of the Vaddis 6E makes it ready for future standards and enhancements.

VIDEO DECODING

The Vaddis 6E supports video decoding of the various MPEG formats and picture sizes supported by DVD, SuperVCD, CVD, VideoCD and DVCD. Frame rates and sizes can be converted between NTSC and PAL. JPEG decoding is supported for PictureCD™ viewing and JPEG file viewing.

AUDIO DECODING

The Vaddis 6E includes a 67 MIPS audio decode processor (ADP) capable of supporting the latest advanced audio algorithms including Dolby Digital™, Pro Logic I/II™, DTS™, MPEG Layer II (including multi-channel), multi-channel LPCM, CD-DA, MP3 and Microsoft® Windows Media Audio™ (WMA).

ZORANZOOM™ AND IMAGE ENHANCEMENT FILTERS

The Vaddis 6E incorporates ZoranZoom™, Zoran's proprietary scaling algorithm and several filtering functions for enhancing the image quality. ZoranZoom™ is the built-in zoom and pan function which provides a crisp image for the resulting enlarged view. The Vaddis 6E supports user picture controls including sharpness (edge enhancement), and brightness adjustments for optimizing the image quality.

OSD, SUB-PICTURE AND CLOSED-CAPTION INSERTION

The On-Screen Display (OSD) unit allows for overlay of custom graphics on the video. The OSD can be frame- or field-based with up to 32 colors and 8 blending levels. The Vaddis 6E supports sub-picture decoding with button highlighting and closed-caption insertion in the vertical blanking region.

ANALOG VIDEO OUTPUT WITH PROGRESSIVE SCAN

The Vaddis 6E includes an advanced video encoder core capable of outputting YPbPr, RGB, Composite, or S-Video via

four high quality 54MHz 10-bit video DACs. The video encoder supports programmable chroma and notch filters to optimize the picture quality, even when displaying on lower quality TV's. The encoder also supports progressive scan video output, with Zoran's proprietary Multi-angle Video Processing (MVP™) for excellent progressive scan image quality.

AUDIO ENHANCEMENT ALGORITHMS

Beyond the decoding of DVD or compressed audio, post-decoding algorithms from Zoran's SiliconSoftware™ library can be applied to enhance the listening experience. Such algorithms include Virtual Surround Sound, 3D Headphones, Graphic Equalization, Karaoke and Music Modes. Virtual Surround Sound gives the listener a multichannel effect through only two speakers. Likewise, 3D Headphones gives the sensation that the listener is surrounded by a theater speaker system, when the audio is actually delivered via the two speakers on the headphones. Graphic Equalization allows the listener to amplify or attenuate various frequency bands of the audio. Karaoke allows mixing of digitized microphone(s) input with playback of the audio with audio effects applied such as echo, voice cancellation and key shift. Music modes expand the sound of the room by simulating a theater or concert hall listening environment. In addition to these algorithms, bass redirection and multi-channel downmixing are supported for all of the various audio standards.

DVD Player Application using the Vaddis ZR36768

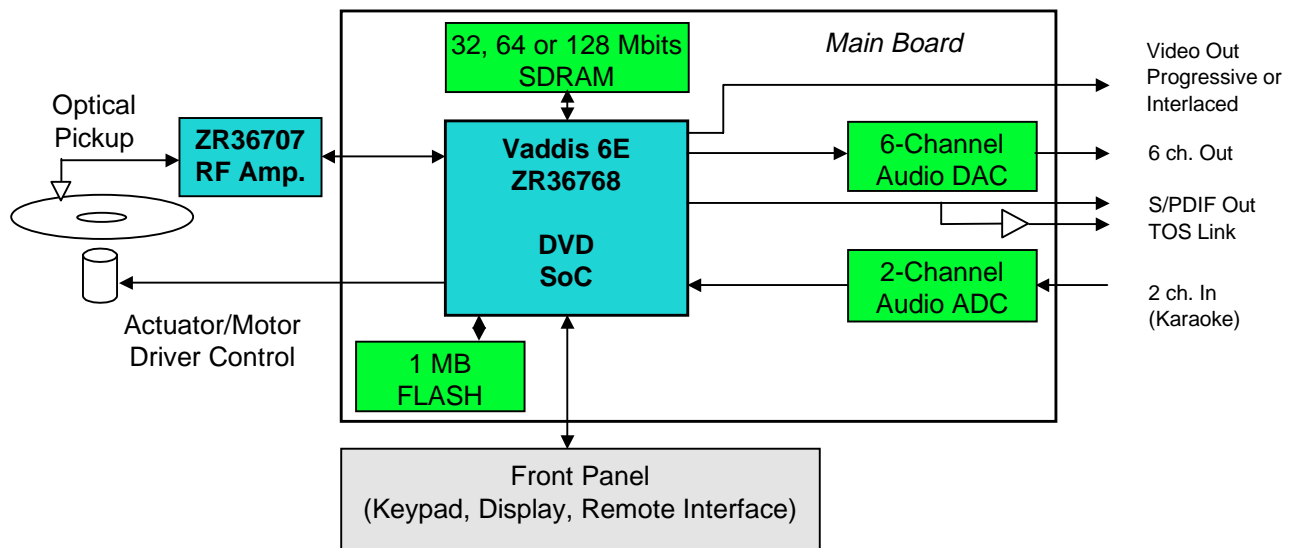

Vaddis 6E incorporates Macrovision and CSS Technologies. To obtain Vaddis 6E, the recipient must have the appropriate licenses with these entities. Due to the programmability of the Vaddis 6E, other licenses may be required. Vaddis, StandardsPlus, SiliconSoftware, ZoranZoom, MVP and Vaddis 6E are trademarks or registered trademarks of Zoran Corp. All other trademarks are property of their respective companies.