

RoHS

- ① Series name
- ② Single output
- ③ Output wattage
- ④ Input voltage
- ⑤ Output voltage

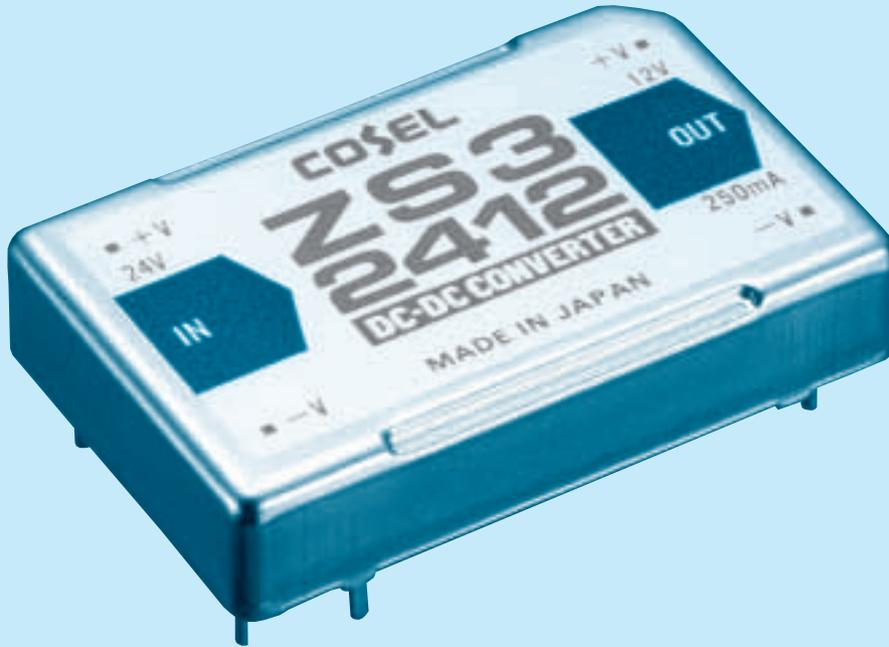

MODEL	ZS30505	ZS30512	ZS30515	ZS31205	ZS31212	ZS31215	ZS32405	ZS32412	ZS32415	ZS34805	ZS34812	ZS34815
MAX OUTPUT WATTAGE[W]	2.5	3.0	3.0	2.5	3.0	3.0	2.5	3.0	3.0	2.5	3.0	3.0
DC OUTPUT	5V 0.5A	12V 0.25A	15V 0.2A	5V 0.5A	12V 0.25A	15V 0.2A	5V 0.5A	12V 0.25A	15V 0.2A	5V 0.5A	12V 0.25A	15V 0.2A

SPECIFICATIONS

	MODEL	ZS30505	ZS30512	ZS30515	ZS31205	ZS31212	ZS31215	ZS32405	ZS32412	ZS32415	ZS34805	ZS34812	ZS34815
INPUT	VOLTAGE[V]	5 (4.5 - 6.0)			12 (10 - 15)			24 (20 - 30)			48 (35 - 63)		
	CURRENT[A]	*1 0.760typ	0.920typ	0.920typ	0.317typ	0.358typ	0.358typ	0.150typ	0.171typ	0.171typ	0.075typ	0.090typ	0.090typ
	EFFICIENCY[%]	65typ	65typ	65typ	65typ	70typ	70typ	70typ	74typ	74typ	70typ	70typ	70typ
OUTPUT	VOLTAGE[V]	5	12	15	5	12	15	5	12	15	5	12	15
	CURRENT[A]	0.5	0.25	0.2	0.5	0.25	0.2	0.5	0.25	0.2	0.5	0.25	0.2
	LINE REGULATION[mV]	25max	60max	75max	25max	60max	75max	25max	60max	75max	25max	60max	75max
	LOAD REGULATION[mV]	50max	120max	150max	50max	120max	150max	50max	120max	150max	50max	120max	150max
	RIPPLE[mVp-p]	*2 100max	120max	120max	100max	120max	120max	100max	120max	120max	100max	120max	120max
	RIPPLE NOISE[mVp-p]	*2 120max	120max	120max	120max	120max	120max	120max	120max	120max	120max	120max	120max
	TEMPERATURE REGULATION[mV]	0 to +50°C			50max			120max			150max		
	OUTPUT VOLTAGE ADJUSTMENT RANGE[V]	Fixed											
OUTPUT VOLTAGE SETTING[%]	±5max (Rated input/output, Ta=25°C)												
PROTECTION CIRCUIT	OVERCURRENT PROTECTION	Works over 105% of rating and recovers automatically											
	INPUT-OUTPUT	AC500V 1minute, Cutoff current = 10mA, DC500V 50MΩ min (20±15°C)											
	INPUT-CASE	AC500V 1minute, Cutoff current = 10mA, DC500V 50MΩ min (20±15°C)											
ISOLATION	OUTPUT-CASE	AC500V 1minute, Cutoff current = 10mA, DC500V 50MΩ min (20±15°C)											
	OPERATING TEMP., HUMID. AND ALTITUDE	-10 to +60°C, 20 - 90%RH (Non condensing) (Refer to DERATING CURVE), 3,000m (10,000feet) max											
	STORAGE TEMP., HUMID. AND ALTITUDE	-20 to +75°C, 20 - 90%RH (Non condensing), 9,000m (30,000feet) max											
ENVIRONMENT	VIBRATION	10 - 55Hz, 19.6m/s ² (2G), 3minutes period, 30minutes each along X, Y and Z axis											
	IMPACT	490.3m/s ² (50G), 11ms, once each X, Y and Z axis											

*1 Rated input 5V, 12V, 24V or 48V DC, Io=100%

*2 Measured by 20MHz oscilloscope.

* Parallel operation with other model is not possible.

External view

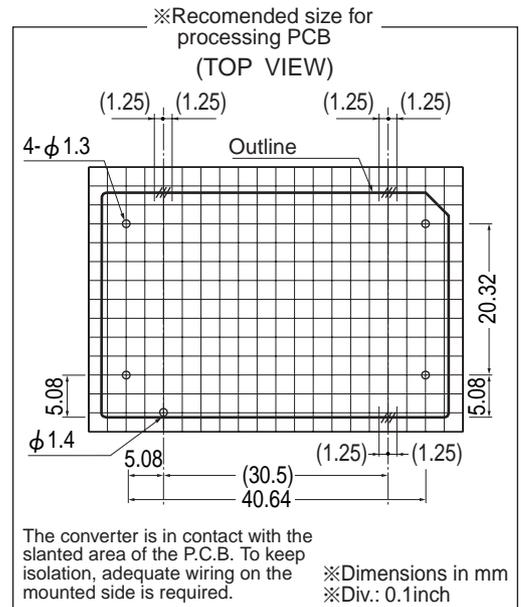
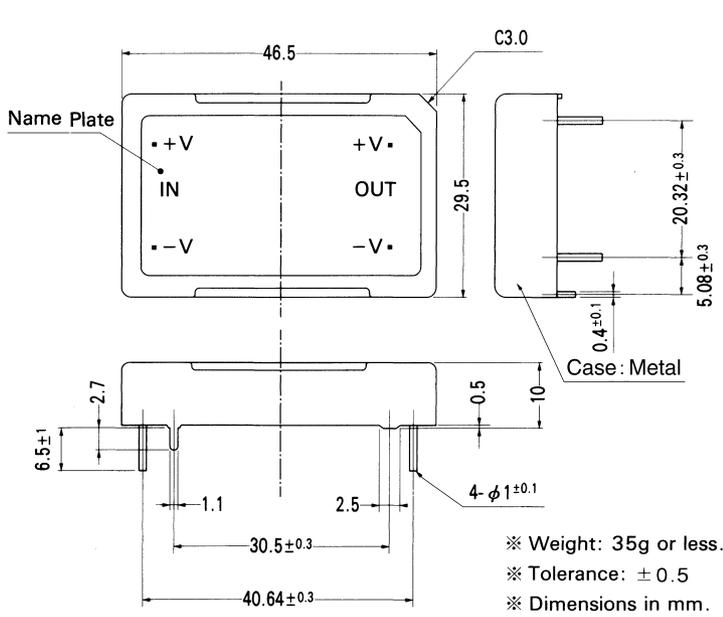

Performance data

■ STATIC CHARACTERISTICS (ZS32405)

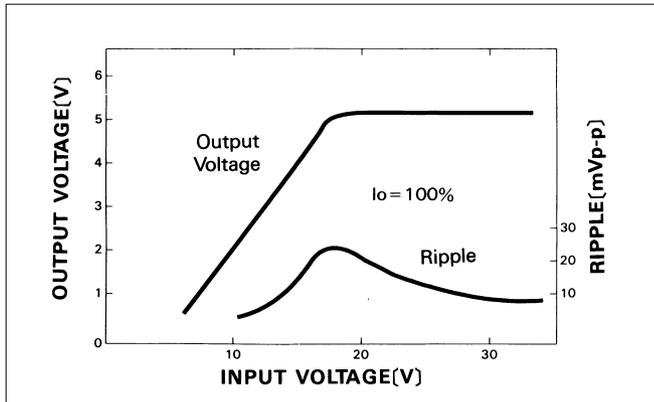

■ RISE TIME & FALL TIME (ZS32405)

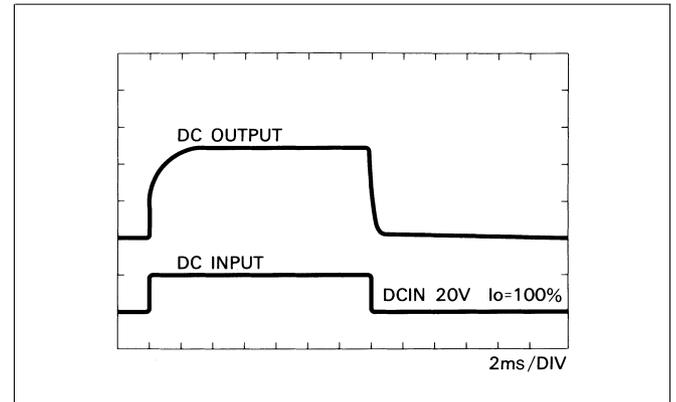

■ OVERCURRENT CHARACTERISTICS (ZS32405)

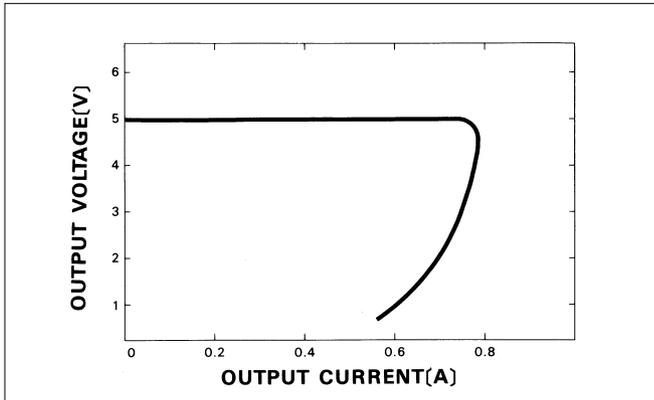

■ DERATING CURVE

