

Coaxial Switch GaAs

NON-CATALOG

ZSWA-4-30DR+

50Ω SP4T, TTL Driver, Absorptive DC¹ to 3 GHz



CASE STYLE: CV665

Connectors	Model
SMA	ZSWA-4-30DR+

+RoHS Compliant

The +Suffix identifies RoHS Compliance. See our web site for RoHS Compliance methodologies and qualifications

Maximum Ratings

Operating Temperature	-30°C to 85°C
Storage Temperature	-55°C to 100°C
Input Power	see Table
Vcontrol	(V+) +0.4V

Permanent damage may occur if any of these limits are exceeded.

Coaxial/Pin Connections

RF IN	1
RF OUT 1	2
RF OUT 2	3
RF OUT 3	4
RF OUT 4	5
CONTROL 1	C5
CONTROL 2	C3
CONTROL 3	C4
CONTROL 4	C6
+5V (V+)	C2
-5V (V-)	C1

Outline Drawing

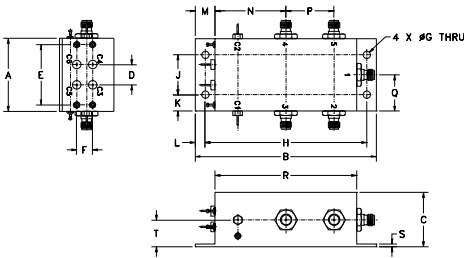

Outline Dimensions (inch/mm)

A	B	C	D	E	F	G	H	J	K
1.61	4.00	1.20	.45	1.33	.35	.161	3.560	.880	.36
40.89	101.60	30.48	11.43	33.78	8.89	4.09	90.42	22.35	9.14
L	M	N	P	Q	R	S	T	wt	
.22	.44	1.56	1.06	.80	3.12	.06	.59	grams	
5.59	11.18	39.62	26.92	20.32	79.25	1.52	14.99	150.0	

Features

- wideband, DC to 3 GHz
- low video leakage, 30 mVp-p typ.
- high isolation, 37 dB typ. @ 2 GHz
- integral TTL driver

Applications

- transmitter/receiver isolation
- automated switching networks
- cellular
- PCN

Electrical Specifications

FREQ. ¹ (GHz)	INSERTION LOSS (dB)						1dB COMPR. (dBm)			IN-OUT ISOLATION (dB)						
	DC-500 MHz		500-2000 MHz		2000-3000 MHz		DC-500 MHz	500-2000 MHz	2000-3000 MHz	DC-500 MHz		500-2000 MHz		2000-3000 MHz		
f _L	f _U	Typ.	Max.	Typ.	Max.	Typ.	Max.	Typ.	Typ.	Typ.	Typ.	Min.	Typ.	Min.	Typ.	Min.
DC	3	1.0	1.8	1.5	3.0	2.0	3.9	23*	25	25	50	40	37	32	31	26

¹1dB compression gradually decreases to 10 dBm at 1 MHz

Additional Specifications

*TTL Control Voltage Low Threshold, V	0/V+		
High Threshold, V	0.8 max. 3.5 min.		
TTL Control Current, mA	0.2 max. 0.02 max.		
High V, mA	+5±0.5		
Low V, mA	-5±0.25		
Positive Supply V. (V+)	4 max		
Negative Supply V. (V-)	20 max.		
Positive Supply Current, mA	1.28 typ., ON 1.24 typ., OFF DC-2GHz		
Negative Supply Current, mA	25 typ.		
VSWR(:1)	45 typ.		
Rise/Fall time (10%-90%), ns	30 typ.		
Switching time, 50% of Control to 90% RF (Turn-on), ns	30X10 ⁶		
10% RF (Turn-off), ns			
**Video Leakage, mVp-p 0/+5V Control			
MTBF, hrs @85°C case			
Max. Input Power, dBm	DC-100 MHz	100-500 MHz	500-3000 MHz
Steady state control	+20	+24	+30
As Modulator	+8	+14	+20

* Do not apply control voltage high prior to applying V+

** Video leakage or break through is defined as leakage of TTL switching signal to RF output ports.
1. All RF connections must be DC blocked or held at 0V DC.

CONTROL LOGIC

Control Ports				RF outputs			
1	2	3	4	1	2	3	4
Low	High	High	High	On	Off	Off	Off
High	Low	High	High	Off	On	Off	Off
High	High	Low	High	Off	Off	On	Off
High	High	High	Low	Off	Off	Off	On

Electrical Schematic

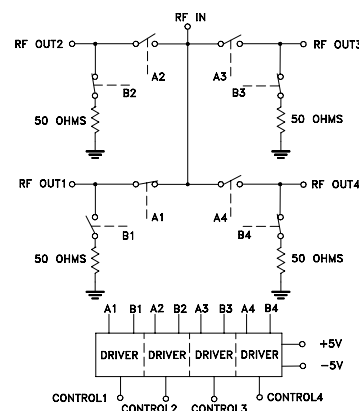

Notes

- Performance and quality attributes and conditions not expressly stated in this specification document are intended to be excluded and do not form a part of this specification document.
- Electrical specifications and performance data contained in this specification document are based on Mini-Circuit's applicable established test performance criteria and measurement instructions.
- The parts covered by this specification document are subject to Mini-Circuits standard limited warranty and terms and conditions (collectively, "Standard Terms"); Purchasers of this part are entitled to the rights and benefits contained therein. For a full statement of the Standard Terms and the exclusive rights and remedies thereunder, please visit Mini-Circuits' website at www.minicircuits.com/MCLStore/terms.jsp



Typical Performance Data

FREQ. (MHz)	ON INSERTION LOSS (dB) TTL Low @ 0V IN-OUT		OFF ISOLATION (dB) TTL High @ 5V IN-OUT		VSWR IN	VSWR OUT ON	VSWR OUT OFF
	\bar{x}	σ	\bar{x}	σ			
1.00	0.59	0.007	94.53	1.66	1.05	1.07	1.29
125.75	0.87	0.008	62.61	0.49	1.14	1.08	1.26
250.50	0.97	0.007	57.54	0.31	1.10	1.14	1.26
375.25	1.02	0.011	54.64	0.24	1.22	1.19	1.27
500.00	1.09	0.012	52.17	0.23	1.26	1.24	1.28
687.50	1.28	0.011	49.37	0.19	1.46	1.31	1.30
875.00	1.35	0.010	47.33	0.26	1.53	1.34	1.35
1062.50	1.47	0.013	45.96	0.26	1.49	1.37	1.38
1250.00	1.47	0.017	44.64	0.20	1.45	1.35	1.37
1437.50	1.51	0.021	44.41	0.25	1.37	1.34	1.41
1625.00	1.50	0.022	44.27	0.34	1.24	1.35	1.41
1812.50	1.63	0.036	43.69	0.29	1.35	1.31	1.41
2000.00	1.73	0.040	44.05	0.31	1.25	1.29	1.42
2333.33	1.80	0.042	42.78	0.29	1.66	1.30	1.37
2444.44	1.89	0.058	43.76	0.34	1.38	1.34	1.35
2555.56	1.90	0.055	42.68	0.34	1.54	1.38	1.31
2666.67	2.03	0.062	41.94	0.29	1.60	1.33	1.31
2777.78	2.07	0.069	42.93	0.42	1.27	1.45	1.25
2888.89	2.18	0.072	41.51	0.36	1.51	1.40	1.29
3000.00	2.28	0.078	41.43	0.38	1.65	1.47	1.22

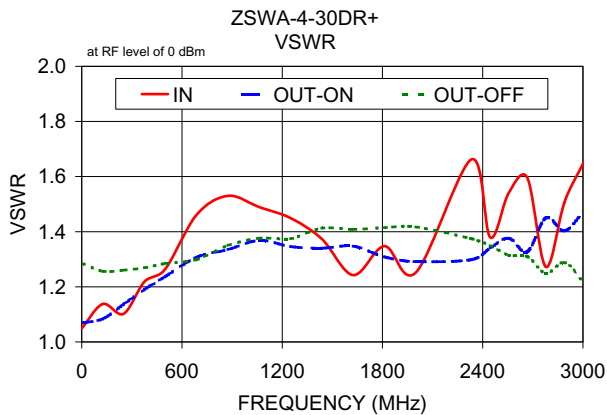
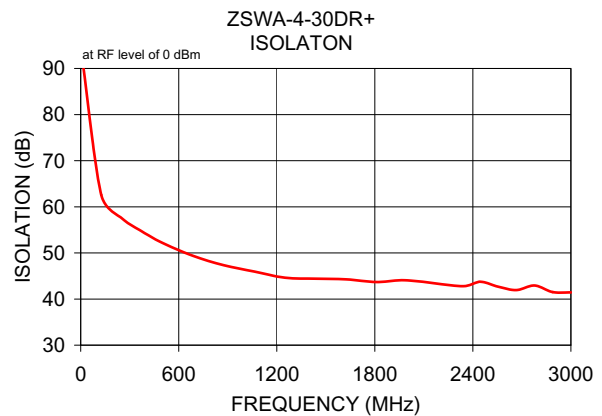
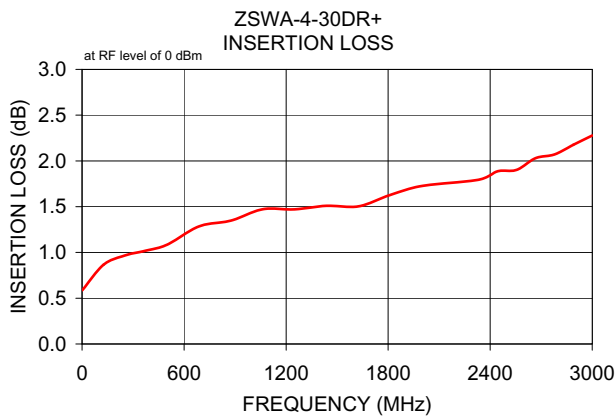

Notes

- A. Performance and quality attributes and conditions not expressly stated in this specification document are intended to be excluded and do not form a part of this specification document.
- B. Electrical specifications and performance data contained in this specification document are based on Mini-Circuit's applicable established test performance criteria and measurement instructions.
- C. The parts covered by this specification document are subject to Mini-Circuits standard limited warranty and terms and conditions (collectively, "Standard Terms"); Purchasers of this part are entitled to the rights and benefits contained therein. For a full statement of the Standard Terms and the exclusive rights and remedies thereunder, please visit Mini-Circuits' website at www.minicircuits.com/MCLStore/terms.jsp

