

---

深圳市中意微显示科技有限公司

**SPECIFICATION**

MODEL NO: ZYW40001-A

CUSTOMER:

Customer Approval:

- Approve Specification Only
- Approve Specification and Sample

APPROVED BY
DATE: 2015-06-19

ISSUED DATE: 2015-06-19

PREPARED BY	CHEEK BY	APPROVED BY

联系人:

电话:

地址:

**Tel:**

**Fax:**

E-mail: [yuanxiub@163.com](mailto:yuanxiub@163.com)

Web: [www.zywlcd.com](http://www.zywlcd.com)



---

# Contents

1. Introduction.....	4
1.1 Scope of application .....	4
1.2 Structure:.....	4
1.3 TFT features:.....	4
1.4 Applications:.....	4
2. General specification .....	5
3. Mechanical drawing.....	6
4. ABSOLUTE MAXIMUM RATINGS .....	7
5. ELECTRICAL CHARACTERISTICS .....	7
6. OPTICAL CHARACTERISTICS.....	8
7.MCU Interface Pin Function .....	10
8. AC Characteristics .....	11
8.1 Parallel 24/18/16-bit RGB Interface Timing Characteristics.....	11
9.LCM Quality Criteria .....	12
9.1 VISUAL & FUNCTION INSPECTION STANDARD.....	12
9.1.1 Inspection conditions.....	12
9.1.2 Definition.....	12
9.1.3 Sampling Plan.....	12
9.1.4 Criteria (Visual).....	13
9.2 Handling Precautions.....	16
9.3 Operation instructions.....	16
9.4 Storage instructions: .....	17
附件： 以下代码为 L C D 初始化： .....	17
1.ILI9806E 初始化.....	17
2.FL10801 初始化.....	22

---

# 1. Introduction

## 1.1 Scope of application

This specification applies to the Positive type TFT transmissive dot matrix LCD module that is supplied by ZYW electronic science and technology. This LCD module should be designed for mobile phone use. LCD specification: Dots 480xRGBx800.

As to basic specification of the driver IC, refer to the IC (ILI9806E or FL10801) specification and datasheet.

## 1.2 Structure:

Double display structure:

TFT Module + FPC

FULL 16.7M Color 3.97 inch TFT LCD size for LCD;

One bare chip with gold bump (COG) TECH;

SPI+RGB interface;

## 1.3 TFT features:

Structure: TFT PANNEL+IC+FPC;

Transmissive Type LCD

480 dot-source and 800 dot-gate outputs;

16.7M Color can be selected by software;

White LED back light;

## 1.4 Applications:

Mobile phone

## 2. General specification

ITEM	Standard value	UNIT
LCD Type	TFT Transmissive	---
Driver element	a-Si TFT Active matrix	
Number of Dots	480*(RGB)*800	Dots
Pixel Arrangement	RGB Vertical Stripe	
Dot Pitch (W*H)	0.108*0.108	mm
Active Area	51.84(H)*86.4(V)	mm
Viewing Area (W*H)	52.44(H)*87.0(V)	mm
Glass Area (W*H)	55.44*93.90	mm
Viewing Direction	IPS	
Control IC	ILI9806E OR FL10801	
Module Size(W*H*T)	56.34*95.7*1.9	mm
Approx. Weight	TBD	g
Back Light	8 White LED	
Touch Panel Type	-----	
Touch Panel Active Area	-----	mm
Touch Panel View Area	-----	mm



## 4. ABSOLUTE MAXIMUM RATINGS

Parameter	Symbol	Min	Max	Unit
Supply voltage for logic	$V_{DD}$	-0.3	4.6	V
Input voltage for logic	$V_{IN}$	-0.5	$V_{DD} + 0.3$	V
Supply current (One LED)	$I_{LED}$	20	--	mA
Operating temperature	$T_{OP}$	-20	+70	°C
Storage temperature	$T_{ST}$	-30	+80	°C

## 5. ELECTRICAL CHARACTERISTICS

Item	Symbol	Min	Typ	Max	Unit	Applicable terminal
Supply voltage for logic	$V_{DD}$	2.5	2.8	3.0	V	$V_{DD}$
Input voltage	$V_{IL}$	-	-	$0.2 V_{DD}$	V	
	$V_{IH}$	$0.8 V_{DD}$	-	$V_{DD}$	V	
Input leakage current	$I_{LKG}$				$\mu A$	
LED Forward voltage	$V_f$	24	25.6	27.2	V	--
Input backlight current	$I_{LED}$	-	20	-	mA	

## 6. OPTICAL CHARACTERISTICS

ITEM		SYMBOL	CONDITIONS	SPECIFICATIONS			UNIT	NOTE
				MIN.	TYP.	MAX		
Brightness		B	Viewing normal angle	TBD	TBD	--	Cd/m <sup>2</sup>	All left side data are based on DYX' s product reference only
Contrast Ratio		CR		--	800	--	--	
Response Time		Tr+Tf		--	35		ms	
CIE Color coordinate	Red	X <sub>R</sub>		-	0.665	-		
		Y <sub>R</sub>		-	0.323	-		
	Green	X <sub>G</sub>		-	0.272	-		
		Y <sub>G</sub>		-	0.588	-		
	Blue	X <sub>B</sub>		-	0.134	-		
		Y <sub>B</sub>		-	0.121	-		
White	X <sub>w</sub>	-		0.292	-			
	Y <sub>w</sub>	-	0.333	-				
Viewing Angle	Hor.	$\theta_{x+}$	Center CR>=10	--	85	--	Deg.	
		$\theta_{x-}$		--	85	--		
	Ver.	$\theta_{y+}$		--	85	--		
		$\theta_{y-}$		--	85	--		
Uniformity	Un			--	--	--	%	

**Note 1 : Definition of Viewing Angle  $\theta_x$  and  $\theta_y$  :**

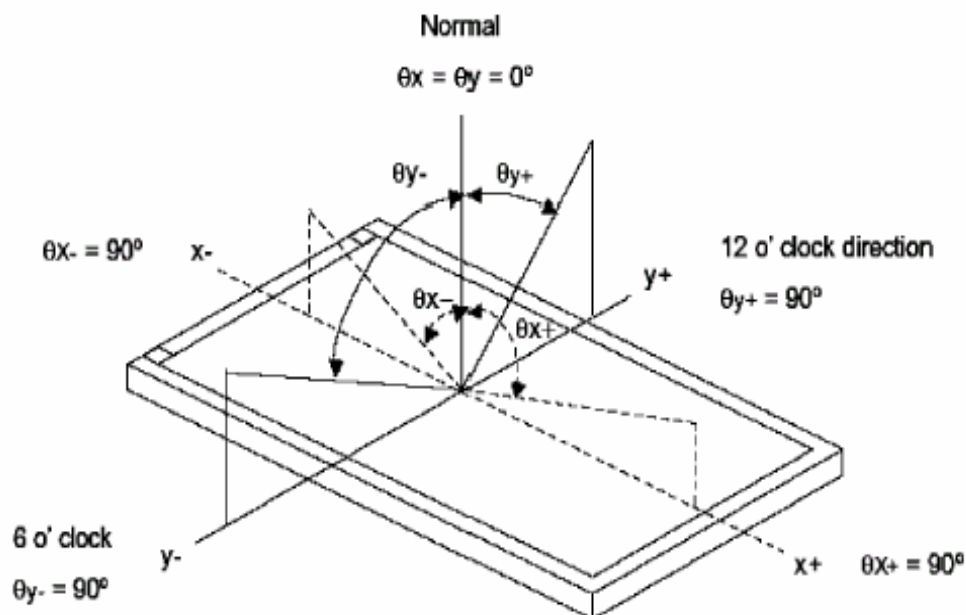

**Note 2: Definition of contrast ratio CR:**



---

$$CR = \frac{\text{Brightness of non-selected dots (white)}}{\text{Brightness of selected dots (black)}}$$

Note 3: Definition of response time ( $T_R$ ,  $T_F$ )

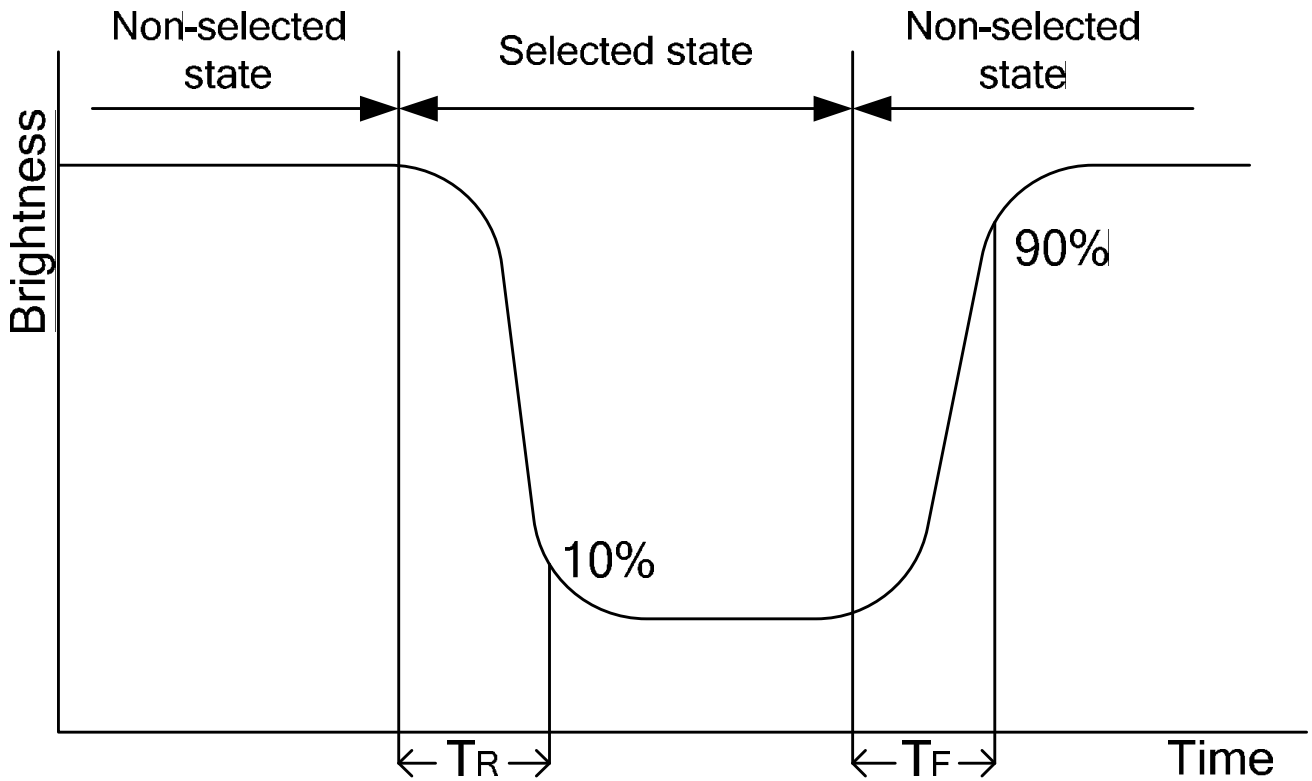

## 7.MCU Interface Pin Function

NO.	SYMBOL	Description
1	GND	Ground
2	VCI/2.8	Power Supply for Analog, Digital System and Booster Circuit.
3	IOVCC/1.8	Power Supply for I/O System.
4	PWM	The PWM frequency output for LED driver control.
5	VS	Frame synchronizing signal for DPI (RGB) interface operation.
6	HS	Line synchronizing signal for DPI (RGB) interface operation.
7	DOTPCLK	Dot clock signal for DPI (RGB) interface operation.
8	DE	Data enable signal for DPI (RGB) interface operation.
9-32	D0-D23	24-bit parallel bi-directional data bus for RGB I/F
33	REST	This signal will reset the device and it must be applied to properly initialize the chip. Signal is active low.
34	CS	Chip selection pin Low enable. High disable.
35	SCL	Serial clock input.
36	SDI	Serial data input pin used for the SPI Interface.
37	SDO	Serial data output pin used for the SPI Interface.
38	A	Backlight +
39	K	Backlight -

## 8. AC Characteristics

### 8.1 Parallel 24/18/16-bit RGB Interface Timing Characteristics

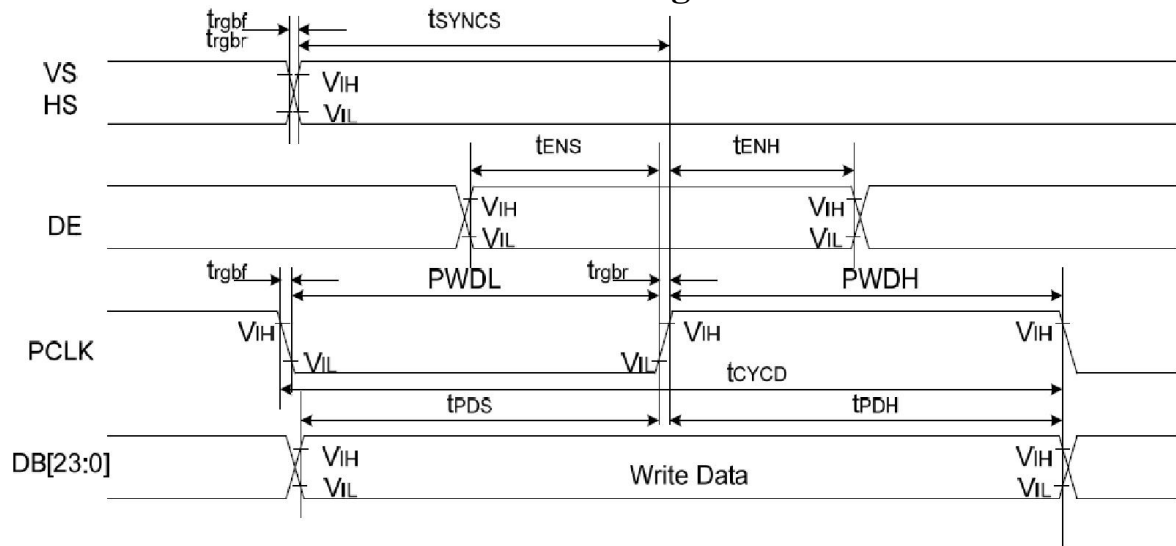

Signal	Symbol	Parameter	min	max	Unit	Description
VS/ HS	$t_{SYNCS}$	VS/HS setup time	5	-	ns	24/18/16-bit bus RGB interface mode
	$t_{SYNCH}$	VS/HS hold time	5	-	ns	
DE	$t_{ENS}$	DE setup time	5	-	ns	
	$t_{ENH}$	DE hold time	5	-	ns	
DB[23:0]	$t_{POS}$	Data setup time	5	-	ns	
	$t_{PDH}$	Data hold time	5	-	ns	
PCLK	PWDH	PCLK high-level period	13	-	ns	
	PWDL	PCLK low-level period	13	-	ns	
	$t_{CYCD}$	PCLK cycle time	28	-	ns	
	$t_{rgbr}, t_{rgbf}$	PCLK,HS,VS rise/fall time	-	15	ns	

Note:  $T_a = -30$  to  $70$  °C,  $IOVCC=1.65V$  to  $3.6V$ ,  $VCI=2.5V$  to  $3.6V$ ,  $DGND=0V$

# 9.LCM Quality Criteria

## 9.1 VISUAL & FUNCTION INSPECTION STANDARD

### 9.1.1 Inspection conditions

Inspection performed under the following conditions is recommended.

Temperature :  $25 \pm 5^{\circ}\text{C}$

Humidity :  $65\% \pm 10\% \text{RH}$

Viewing Angle : Normal viewing Angle.

Illumination: Single fluorescent lamp (300 to 700Lux)

Viewing distance:30-50cm

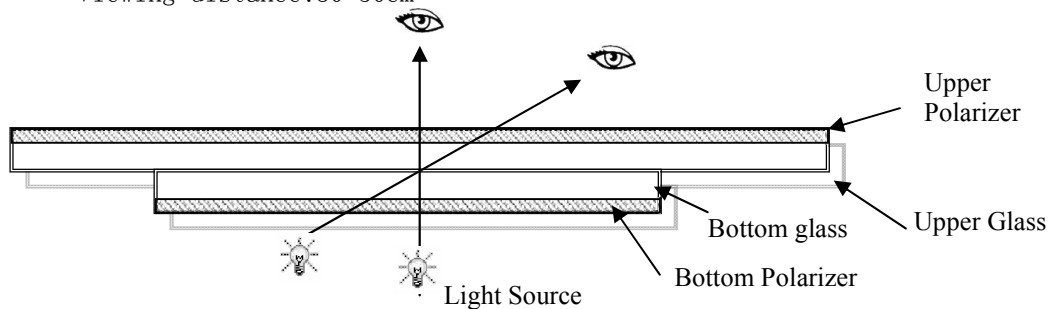

### 9.1.2 Definition

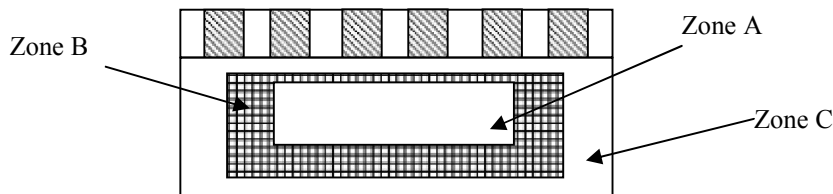

Zone A : Effective Viewing Area(Character or Digit can be seen)

Zone B : Viewing Area except Zone A

Zone C : Outside (Zone A+Zone B) which can not be seen after assembly by customer .)

Note:

As a general rule ,visual defects in Zone C can be ignored when it doesn' t effect product function

or appearance after assembly by customer.

### 9.1.3 Sampling Plan

According to GB/T 2828-2003 ; , normal inspection, Class II

AQL:

Major defect	Minor defect
0.65	1.5

LCD: Liquid Crystal Display , TP: Touch Panel , LCM: Liquid Crystal Module

No	Items to be inspected	Criteria	Classification of defects
1	Functional defects	1) No display, Open or miss line 2) Display abnormally, Short 3) Backlight no lighting, abnormal lighting. 4) TP no function	Major
2	Missing	Missing component	
3	Outline dimension	Overall outline dimension beyond the drawing is not allowed	

4	Color tone	Color unevenness, refer to limited sample	Minor
5	Soldering appearance	Good soldering , Peeling off is not allowed.	
6	LCD/Polarizer/TP	Black/White spot/line, scratch, crack, etc.	

**9.1.4 Criteria (Visual)**

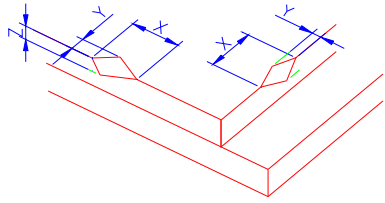
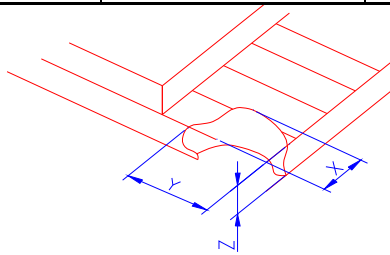
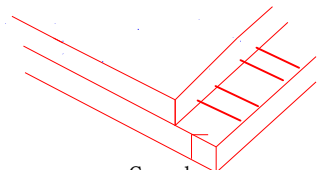
Number	Items	Criteria(mm)						
1.0 LCD Crack/Broken  NOTE: X: Length Y: Width Z: Height L: Length of ITO, T: Height of LCD	(1) The edge of LCD broken	 <table border="1" data-bbox="853 660 1396 817"> <tr> <td>X</td> <td>Y</td> <td>Z</td> </tr> <tr> <td>≤3.0mm</td> <td>&lt;Inner border line of the seal</td> <td>≤T</td> </tr> </table>	X	Y	Z	≤3.0mm	<Inner border line of the seal	≤T
	X	Y	Z					
	≤3.0mm	<Inner border line of the seal	≤T					
(2)LCD corner broken	 <table border="1" data-bbox="912 1108 1337 1182"> <tr> <td>X</td> <td>Y</td> <td>Z</td> </tr> <tr> <td>≤3.0mm</td> <td>≤L</td> <td>≤T</td> </tr> </table>	X	Y	Z	≤3.0mm	≤L	≤T	
X	Y	Z						
≤3.0mm	≤L	≤T						
(3) LCD crack	 <p>Crack Not allowed</p>							

Number	Items	Criteria (mm)
--------	-------	---------------

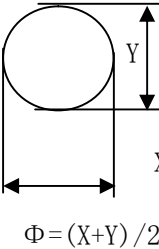
2.0	Spot defect  $\Phi = (X+Y)/2$	① light dot (LCD/TP/Polarizer black/white spot , light dot, pinhole, dent, stain)																									
		<table border="1"> <thead> <tr> <th rowspan="2">Zone Size (mm)</th> <th colspan="3">Acceptable Qty</th> </tr> <tr> <th>A</th> <th>B</th> <th>C</th> </tr> </thead> <tbody> <tr> <td><math>\Phi \leq 0.10</math></td> <td colspan="3">Ignore</td> </tr> <tr> <td><math>0.10 &lt; \Phi \leq 0.15</math></td> <td colspan="3">3 ( distance <math>\geq 10\text{mm}</math>)</td> </tr> <tr> <td><math>0.15 &lt; \Phi \leq 0.2</math></td> <td colspan="3">1</td> </tr> <tr> <td><math>0.2 &lt; \Phi</math></td> <td colspan="3">0</td> </tr> </tbody> </table>	Zone Size (mm)	Acceptable Qty			A	B	C	$\Phi \leq 0.10$	Ignore			$0.10 < \Phi \leq 0.15$	3 ( distance $\geq 10\text{mm}$ )			$0.15 < \Phi \leq 0.2$	1			$0.2 < \Phi$	0				
		Zone Size (mm)		Acceptable Qty																							
			A	B	C																						
$\Phi \leq 0.10$	Ignore																										
$0.10 < \Phi \leq 0.15$	3 ( distance $\geq 10\text{mm}$ )																										
$0.15 < \Phi \leq 0.2$	1																										
$0.2 < \Phi$	0																										
② Dim spot (LCD/TP/Polarizer dim dot, light leakage, dark spot)																											
<table border="1"> <thead> <tr> <th rowspan="2">Zone Size (mm)</th> <th colspan="3">Acceptable Qty</th> </tr> <tr> <th>A</th> <th>B</th> <th>C</th> </tr> </thead> <tbody> <tr> <td><math>\Phi \leq 0.1</math></td> <td colspan="3">Ignore</td> </tr> <tr> <td><math>0.1 &lt; \Phi \leq 0.2</math></td> <td colspan="3">2 ( distance <math>\geq 10\text{mm}</math>)</td> </tr> <tr> <td><math>0.2 &lt; \Phi \leq 0.3</math></td> <td colspan="3">1</td> </tr> <tr> <td><math>\Phi &gt; 0.3</math></td> <td colspan="3">0</td> </tr> </tbody> </table>	Zone Size (mm)	Acceptable Qty			A	B	C	$\Phi \leq 0.1$	Ignore			$0.1 < \Phi \leq 0.2$	2 ( distance $\geq 10\text{mm}$ )			$0.2 < \Phi \leq 0.3$	1			$\Phi > 0.3$	0						
Zone Size (mm)		Acceptable Qty																									
	A	B	C																								
$\Phi \leq 0.1$	Ignore																										
$0.1 < \Phi \leq 0.2$	2 ( distance $\geq 10\text{mm}$ )																										
$0.2 < \Phi \leq 0.3$	1																										
$\Phi > 0.3$	0																										
③ Polarizer accidented spot																											
<table border="1"> <thead> <tr> <th rowspan="2">Zone Size (mm)</th> <th colspan="3">Acceptable Qty</th> </tr> <tr> <th>A</th> <th>B</th> <th>C</th> </tr> </thead> <tbody> <tr> <td><math>\Phi \leq 0.2</math></td> <td colspan="3">Ignore</td> </tr> <tr> <td><math>0.2 &lt; \Phi \leq 0.5</math></td> <td colspan="3">2 ( distance <math>\geq 10\text{mm}</math>)</td> </tr> <tr> <td><math>\Phi &gt; 0.5</math></td> <td colspan="3">0</td> </tr> </tbody> </table>	Zone Size (mm)	Acceptable Qty			A	B	C	$\Phi \leq 0.2$	Ignore			$0.2 < \Phi \leq 0.5$	2 ( distance $\geq 10\text{mm}$ )			$\Phi > 0.5$	0										
Zone Size (mm)		Acceptable Qty																									
	A	B	C																								
$\Phi \leq 0.2$	Ignore																										
$0.2 < \Phi \leq 0.5$	2 ( distance $\geq 10\text{mm}$ )																										
$\Phi > 0.5$	0																										
Line defect (LCD/TP /Polarizer black/white line, scratch, stain)	<table border="1"> <thead> <tr> <th rowspan="2">Width(mm)</th> <th rowspan="2">Length(mm)</th> <th colspan="3">Acceptable Qty</th> </tr> <tr> <th>A</th> <th>B</th> <th>C</th> </tr> </thead> <tbody> <tr> <td><math>\Phi \leq 0.03</math></td> <td>Ignore</td> <td colspan="2">Ignore</td> <td rowspan="3">Ignore</td> </tr> <tr> <td><math>0.03 &lt; W \leq 0.05</math></td> <td><math>L \leq 3.0</math></td> <td colspan="2"><math>N \leq 2</math></td> </tr> <tr> <td><math>0.05 &lt; W \leq 0.08</math></td> <td><math>L \leq 2.0</math></td> <td colspan="2"><math>N \leq 2</math></td> </tr> <tr> <td><math>0.08 &lt; W</math></td> <td colspan="3">Define as spot defect</td> <td></td> </tr> </tbody> </table>	Width(mm)	Length(mm)	Acceptable Qty			A	B	C	$\Phi \leq 0.03$	Ignore	Ignore		Ignore	$0.03 < W \leq 0.05$	$L \leq 3.0$	$N \leq 2$		$0.05 < W \leq 0.08$	$L \leq 2.0$	$N \leq 2$		$0.08 < W$	Define as spot defect			
Width(mm)	Length(mm)			Acceptable Qty																							
		A	B	C																							
$\Phi \leq 0.03$	Ignore	Ignore		Ignore																							
$0.03 < W \leq 0.05$	$L \leq 3.0$	$N \leq 2$																									
$0.05 < W \leq 0.08$	$L \leq 2.0$	$N \leq 2$																									
$0.08 < W$	Define as spot defect																										

3.0	Polarizer Bubble	<table border="1"> <thead> <tr> <th rowspan="2">Zone Size (mm)</th> <th colspan="3">Acceptable Qty</th> </tr> <tr> <th>A</th> <th>B</th> <th>C</th> </tr> </thead> <tbody> <tr> <td><math>\Phi \leq 0.2</math></td> <td colspan="3">Ignore</td> </tr> <tr> <td><math>0.2 &lt; \Phi \leq 0.4</math></td> <td colspan="3">2 (distance <math>\geq 10\text{mm}</math>)</td> </tr> <tr> <td><math>0.4 &lt; \Phi \leq 0.6</math></td> <td colspan="3">1</td> </tr> <tr> <td><math>0.6 &lt; \Phi</math></td> <td colspan="3">0</td> </tr> </tbody> </table>			Zone Size (mm)	Acceptable Qty			A	B	C	$\Phi \leq 0.2$	Ignore			$0.2 < \Phi \leq 0.4$	2 (distance $\geq 10\text{mm}$ )			$0.4 < \Phi \leq 0.6$	1			$0.6 < \Phi$	0			
		Zone Size (mm)	Acceptable Qty																									
			A	B	C																							
		$\Phi \leq 0.2$	Ignore																									
		$0.2 < \Phi \leq 0.4$	2 (distance $\geq 10\text{mm}$ )																									
$0.4 < \Phi \leq 0.6$	1																											
$0.6 < \Phi$	0																											
4.0	SMT	According to IPC-A-610C class II standard . Function defect and missing part are major defect , the others are minor defect.																										
5.0	TP Related	TP bubble/ accidented spot	<table border="1"> <thead> <tr> <th rowspan="2">Size <math>\Phi</math> (mm)</th> <th colspan="3">Acceptable Qty</th> </tr> <tr> <th>A</th> <th>B</th> <th>C</th> </tr> </thead> <tbody> <tr> <td><math>\Phi \leq 0.1</math></td> <td colspan="3">Ignore</td> </tr> <tr> <td><math>0.1 &lt; \Phi \leq 0.2</math></td> <td colspan="3">2</td> </tr> <tr> <td><math>0.2 &lt; \Phi \leq 0.3</math></td> <td colspan="3">1</td> </tr> <tr> <td><math>0.3 &lt; \Phi</math></td> <td colspan="3">0</td> </tr> </tbody> </table>			Size $\Phi$ (mm)	Acceptable Qty			A	B	C	$\Phi \leq 0.1$	Ignore			$0.1 < \Phi \leq 0.2$	2			$0.2 < \Phi \leq 0.3$	1			$0.3 < \Phi$	0		
			Size $\Phi$ (mm)	Acceptable Qty																								
				A	B	C																						
			$\Phi \leq 0.1$	Ignore																								
$0.1 < \Phi \leq 0.2$	2																											
$0.2 < \Phi \leq 0.3$	1																											
$0.3 < \Phi$	0																											
Assembly deflection	beyond the edge of backlight $\leq 0.15\text{mm}$																											
Newton Ring	Newton Ring area $> 1/3$ TP area NG  Newton Ring area $\leq 1/3$ TP area OK																											

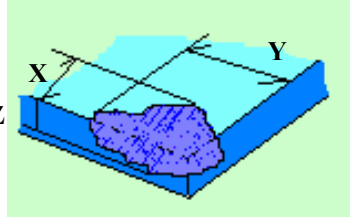
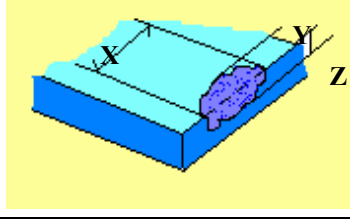
		TP corner broken X: length Y: width Z: height	<table border="1"> <tr> <td>X</td> <td>Y</td> <td>Z</td> </tr> <tr> <td><math>X \leq 3.0\text{mm}</math></td> <td><math>Y \leq 3.0\text{mm}</math></td> <td><math>Z &lt; \text{LCD thickness}</math></td> </tr> </table>	X	Y	Z	$X \leq 3.0\text{mm}$	$Y \leq 3.0\text{mm}$	$Z < \text{LCD thickness}$	
		X	Y	Z						
$X \leq 3.0\text{mm}$	$Y \leq 3.0\text{mm}$	$Z < \text{LCD thickness}$								
	* Circuitry broken is not allowed.									
		TP edge broken X: length Y: width Z: height	<table border="1"> <tr> <td>X</td> <td>Y</td> <td>Z</td> </tr> <tr> <td><math>X \leq 6.0\text{mm}</math></td> <td><math>Y \leq 2.0\text{mm}</math></td> <td><math>Z &lt; \text{LCD thickness}</math></td> </tr> </table>	X	Y	Z	$X \leq 6.0\text{mm}$	$Y \leq 2.0\text{mm}$	$Z < \text{LCD thickness}$	
		X	Y	Z						
$X \leq 6.0\text{mm}$	$Y \leq 2.0\text{mm}$	$Z < \text{LCD thickness}$								
	* Circuitry broken is not allowed.									

Criteria ( functional items)

Number	Items	Criteria (mm)
1	No display	Not allowed
2	Missing segment	Not allowed
3	Short	Not allowed
4	Backlight no lighting	Not allowed
5	TP no function	Not allowed

## 9.2 Handling Precautions

9.2.1 Avoid static electricity damaging the LSI.

9.2.2 Do not remove the panel or frame from the module .

9.2.3 The polarizing plate of the display is very fragile . So, please handle it very carefully.

9.2.4 Do not wipe the polarizing plate with a dry cloth, as it may easily scratch the surface of the plate.

9.2.5 The color tone of display and background of LCM has the possibility to be changed in the storage temperature range.

9.2.6 Pay attention to the working environment, as the element may be destroyed by static electricity.

--Be sure to ground human body and electric appliance during work.

--Avoid working in a dry environment to minimize the generations of static electricity.

--Static electricity may be generated when the protective film is fast peeled off.

9.2.7 When soldering the terminal of LCM, make certain the AC power source of soldering iron does not leak.

10.4.8 If the display surface becomes contaminated ,breathe on the surface and gently wipe it with a soft-dry- clean cloth .If it is heavily contaminated ,moisten cloth with the following solvent(ex:Ethyl alcohol).Solvents other than those above-mentioned may damage the polarizer(Especially ,do not use them .ex: Warter / Ketone)

## 9.3 Operation instructions

9.3.1 It is recommended to drive the LCD within the specified voltage limits, try to adjust the operating voltage for the optimal contrast, the color and contrast of LCD panel will varies at different temperature.

9.3.2 Response time is greatly delayed at low operating temperature range. However, this does not mean the LCD will be out of the order, It will recover when it returns to the specified temperature range.

9.3.3 If the display area is pushed hard during operation, the display will become abnormal.



---

9.3.4 Do not operate the LCD at the environments over the specified conditions, this may cause damage on the LCD and shorten the lifetime.

## 9.4 Storage instructions:

9.4.1 Store LCDs in a sealed polyethylene bag.

9.4.2 Store LCDs in a dark place, Do not expose to sunlight or fluorescent light. Keep the temperature between 0°C and 35°C.

9.4.3 Avoid the polarizer touch any other object, ( It is recommended to store them in the container in which they were shipped.)

## 附件：以下代码为LCD初始化：

### 1. ILI9806E 初始化

```
REGISTER, FF, 5, FF, 98, 06, 04, 00    // Change to Page 0

REGISTER, 20, 1, 00

REGISTER, FF, 5, FF, 98, 06, 04, 01    // Change to Page 1

REGISTER, 08, 1, 10                    // output SDA

REGISTER, 21, 1, 01                    // DE = 1 Active

REGISTER, 30, 1, 02                    // 480 X 800

REGISTER, 31, 1, 02                    // 2-Dot Inversion

REGISTER, 60, 1, 07                    // SDTI

REGISTER, 61, 1, 06                    // CRTI

REGISTER, 62, 1, 06                    // EQTI

REGISTER, 63, 1, 04                    // PCTI

REGISTER, 40, 1, 14                    // BT +2.5/-2.5 pump for DDVDH-L

REGISTER, 41, 1, 55                    // DVDDH DVDDL clamp

REGISTER, 42, 1, 11                    // VGH/VGL

REGISTER, 43, 1, 09                    // VGH clamp

REGISTER, 44, 1, 0C                    // VGL clamp

REGISTER, 45, 1, 14                    // VGL_REG -10V

REGISTER, 50, 1, 50                    // VGMP

REGISTER, 51, 1, 50                    // VGMN
```

---

REGISTER, 52, 1, 00 //Flicker

REGISTER, 53, 1, 47 //Flicker4F

//+++++++ Gamma Setting ++++++//

REGISTER, A0, 1, 00 // Gamma 0 /255

REGISTER, A1, 1, 09 // Gamma 4 /251

REGISTER, A2, 1, 0C // Gamma 8 /247

REGISTER, A3, 1, 0F // Gamma 16 /239

REGISTER, A4, 1, 06 // Gamma 24 /231

REGISTER, A5, 1, 09 // Gamma 52 / 203

REGISTER, A6, 1, 07 // Gamma 80 / 175

REGISTER, A7, 1, 16 // Gamma 108 /147

REGISTER, A8, 1, 06 // Gamma 147 /108

REGISTER, A9, 1, 09 // Gamma 175 / 80

REGISTER, AA, 1, 11 // Gamma 203 / 52

REGISTER, AB, 1, 06 // Gamma 231 / 24

REGISTER, AC, 1, 0E // Gamma 239 / 16

REGISTER, AD, 1, 19 // Gamma 247 / 8

REGISTER, AE, 1, 0C // Gamma 251 / 4

REGISTER, AF, 1, 00 // Gamma 255 / 0

///=====Nagitive

REGISTER, C0, 1, 00 // Gamma 0 /255

REGISTER, C1, 1, 09 // Gamma 4 /251

REGISTER, C2, 1, 0C // Gamma 8 /247

REGISTER, C3, 1, 0F // Gamma 16 /239

REGISTER, C4, 1, 06 // Gamma 24 /231

REGISTER, C5, 1, 09 // Gamma 52 /203

REGISTER, C6, 1, 07 // Gamma 80 /175

---

REGISTER, C7, 1, 16 // Gamma 108 /147  
REGISTER, C8, 1, 06 // Gamma 147 /108  
REGISTER, C9, 1, 09 // Gamma 175 /80  
REGISTER, CA, 1, 11 // Gamma 203 /52  
REGISTER, CB, 1, 06 // Gamma 231 /24  
REGISTER, CC, 1, 0E // Gamma 239 /16  
REGISTER, CD, 1, 19 // Gamma 247 /8  
REGISTER, CE, 1, 0C // Gamma 251 /4  
REGISTER, CF, 1, 00 // Gamma 255  
REGISTER, FF, 5, FF, 98, 06, 04, 07 // Change to Page 7

REGISTER, 17, 1, 32  
REGISTER, 06, 1, 13  
REGISTER, 02, 1, 77  
REGISTER, 18, 1, 1D  
REGISTER, E1, 1, 79

//=====//

REGISTER, FF, 5, FF, 98, 06, 04, 06 // Change to Page 6  
REGISTER, 00, 1, A0  
REGISTER, 01, 1, 05  
REGISTER, 02, 1, 00  
REGISTER, 03, 1, 00  
REGISTER, 04, 1, 01  
REGISTER, 05, 1, 01  
REGISTER, 06, 1, 88  
REGISTER, 07, 1, 04  
REGISTER, 08, 1, 01  
REGISTER, 09, 1, 90

---

REGISTER, 0A, 1, 04  
REGISTER, 0B, 1, 01  
REGISTER, 0C, 1, 01  
REGISTER, 0D, 1, 01  
REGISTER, 0E, 1, 00  
REGISTER, 0F, 1, 00  
REGISTER, 10, 1, 55  
REGISTER, 11, 1, 50  
REGISTER, 12, 1, 01  
REGISTER, 13, 1, 85  
REGISTER, 14, 1, 85  
REGISTER, 15, 1, C0  
REGISTER, 16, 1, 0B  
REGISTER, 17, 1, 00  
REGISTER, 18, 1, 00  
REGISTER, 19, 1, 00  
REGISTER, 1A, 1, 00  
REGISTER, 1B, 1, 00  
REGISTER, 1C, 1, 00  
REGISTER, 1D, 1, 00  
REGISTER, 20, 1, 01  
REGISTER, 21, 1, 23  
REGISTER, 22, 1, 45  
REGISTER, 23, 1, 67  
REGISTER, 24, 1, 01  
REGISTER, 25, 1, 23  
REGISTER, 26, 1, 45

---

REGISTER, 27, 1, 67  
REGISTER, 30, 1, 02  
REGISTER, 31, 1, 22  
REGISTER, 32, 1, 11  
REGISTER, 33, 1, AA  
REGISTER, 34, 1, BB  
REGISTER, 35, 1, 66  
REGISTER, 36, 1, 00  
REGISTER, 37, 1, 22  
REGISTER, 38, 1, 22  
REGISTER, 39, 1, 22  
REGISTER, 3A, 1, 22  
REGISTER, 3B, 1, 22  
REGISTER, 3C, 1, 22  
REGISTER, 3D, 1, 22  
REGISTER, 3E, 1, 22  
REGISTER, 3F, 1, 22  
REGISTER, 40, 1, 22  
REGISTER, 52, 1, 12  
REGISTER, 53, 1, 12 //VGLO refer VGL\_REG 1A  
  
//\*\*\*\*\*  
//\*\*\*\*\* Page 0 Command \*\*\*\*\*  
//\*\*\*\*\*  
  
REGISTER, FF, 5, FF, 98, 06, 04, 00 // Change to Page 0  
REGISTER, 11, 1, 00 // Sleep-Out  
DELAY, 120  
REGISTER, 29, 1, 00 // Display On

---

## 2.FL10801 初始化

```
SPI_WriteComm(0xB9);
SPI_WriteData(0xF1);
SPI_WriteData(0x08);
SPI_WriteData(0x01);

SPI_WriteComm(0xB1);
SPI_WriteData(0x02);
SPI_WriteData(0x1E);
SPI_WriteData(0x1E);
SPI_WriteData(0x87);
SPI_WriteData(0x30);
SPI_WriteData(0x01);
SPI_WriteData(0x8B); //8b

SPI_WriteComm(0xB2);
SPI_WriteData(0x23); //480x800

SPI_WriteComm(0x36);
SPI_WriteData(0x40);

SPI_WriteComm(0xB3);
SPI_WriteData(0x00);
SPI_WriteData(0x00);
SPI_WriteData(0x06);
SPI_WriteData(0x06); //VBP
SPI_WriteData(0x20);
SPI_WriteData(0x20); //VFP_GEN
SPI_WriteData(0x30);
SPI_WriteData(0x30); //HFP_GEN

SPI_WriteComm(0xBA); // Set DSI
SPI_WriteData(0x31); //1
SPI_WriteData(0x00); //2
SPI_WriteData(0x44); //3
```

---

```
SPI_WriteData(0x25); //4
SPI_WriteData(0x91); //5
SPI_WriteData(0x0A); //6
SPI_WriteData(0x00); //7
SPI_WriteData(0x00); //8
SPI_WriteData(0xC1); //9
SPI_WriteData(0x00); //10
SPI_WriteData(0x00); //11
SPI_WriteData(0x00); //12
SPI_WriteData(0x0D); //13
SPI_WriteData(0x02); //14
SPI_WriteData(0x4F); //15
SPI_WriteData(0xB9); //16
SPI_WriteData(0xEE); //17

SPI_WriteComm(0xE3); //
SPI_WriteData(0x05); //
SPI_WriteData(0x05); //
SPI_WriteData(0x01); //
SPI_WriteData(0x01); //
SPI_WriteData(0x00); //

SPI_WriteComm(0xB4);
SPI_WriteData(0x00);

SPI_WriteComm(0xB5);
SPI_WriteData(0x09);
SPI_WriteData(0x09);

SPI_WriteComm(0xB6); // Set VCOM
SPI_WriteData(0x38); //VCOM OSET
SPI_WriteData(0x38); //VCOM OSET

SPI_WriteComm(0xB8);
SPI_WriteData(0x64); //PCCS11
```

---

```

SPI_WriteData(0x20); //2.5x, -2.5x

SPI_WriteComm(0xCC);
SPI_WriteData(0x0A);

SPI_WriteComm(0xBC);
SPI_WriteData(0x47);

SPI_WriteComm(0xE9); //GIP
SPI_WriteData(0x00); // 1 //VBTH VBTL
SPI_WriteData(0x00); // 2 //SHR0
SPI_WriteData(0x06); // 3 //SHR0 18
SPI_WriteData(0x00); // 4 //SHR1 03
SPI_WriteData(0x00); // 5 //SHR1 3C
SPI_WriteData(0x81); // 6 //SON
SPI_WriteData(0x89); // 7 //SO
SPI_WriteData(0x12); // 8 //SHR0_1, SHR0_2
SPI_WriteData(0x31); // 9 //SHR0_3, SHR1_1
SPI_WriteData(0x23); //10 //SHR1_2, SHR1_3
SPI_WriteData(0x23); //11 //SHP, SCP
SPI_WriteData(0x08); //12 //CHR,
SPI_WriteData(0x81); //13 //15//CON,
SPI_WriteData(0x80); //14 //CO
SPI_WriteData(0x23); //15 //CHP, CCP
SPI_WriteData(0x00); //16 //CGS
SPI_WriteData(0x00); //17 //CGS
SPI_WriteData(0x10); //18 //CGS GOUT5
SPI_WriteData(0x00); //19 //CGS_INV
SPI_WriteData(0x00); //20 //CGS_INV
SPI_WriteData(0x00); //21 //CGS_INV
SPI_WriteData(0x0F); //22 //USER_GIP
SPI_WriteData(0x89); //23 //COSL1, COS2 // , FW
SPI_WriteData(0x13); //24 //COSL3, CS04 //CKV1, CK1B
SPI_WriteData(0x18); //25 //COSL5, COS6 //STVL, BW
SPI_WriteData(0x88); //26 //COSL7, COS8

```



---

```

SPI_WriteData(0x88); //27 //COSL9, COS10
SPI_WriteData(0x88); //28 //COSL11, COS12
SPI_WriteData(0x88); //29 //COSL13, COS14
SPI_WriteData(0x88); //30 //COSL15, COS16
SPI_WriteData(0x88); //31 //COSL17, COS18
SPI_WriteData(0x89); //32 //COSR1, COS2 // , FW
SPI_WriteData(0x02); //33 //COSL3, CS04 //CKV2, CKV2B
SPI_WriteData(0x08); //34 //COSL5, COS6 //STVR, BW
SPI_WriteData(0x88); //35 //COSR7, COS8
SPI_WriteData(0x88); //36 //COSR9, COS10
SPI_WriteData(0x88); //37 //COSR11, COS12
SPI_WriteData(0x88); //38 //COSR13, COS14
SPI_WriteData(0x88); //39 //COSR15, COS16
SPI_WriteData(0x88); //40 //COSR17, COS18
SPI_WriteData(0x00); //41 //OPTION
SPI_WriteData(0x00); //42 //OPTION
SPI_WriteData(0x00); //43 //OTPTION
SPI_WriteData(0x00); //44 //OPTION
SPI_WriteData(0x00); //45 //CHR2
SPI_WriteData(0x00); //46 //CON2
SPI_WriteData(0x00); //47 //C02
SPI_WriteData(0x00); //48 //CHP, CCP
SPI_WriteData(0x00); //49 //CKS
SPI_WriteData(0x00); //50 //CKS
SPI_WriteData(0x00); //51 //CKS

SPI_WriteComm(0xEA); // Set GIP2
SPI_WriteData(0x90); //1
SPI_WriteData(0x00); //2
SPI_WriteData(0x00); //3
SPI_WriteData(0x00); //4
SPI_WriteData(0x88); //5 //COSL1, COS2 // , BW
SPI_WriteData(0x20); //6 //COSL3, CS04 //CKV1, CK1B
SPI_WriteData(0x09); //7 //COSL5, COS6 //STVL, FW
SPI_WriteData(0x88); //8 //COSL7, COS8

```

---

```
SPI_WriteData(0x88); //9 //COSL9, COS10
SPI_WriteData(0x88); //10 //COSL11, COS12
SPI_WriteData(0x88); //11 //COSL13, COS14
SPI_WriteData(0x88); //12 //COSL15, COS16
SPI_WriteData(0x88); //13 //COSL17, COS18
SPI_WriteData(0x88); //14 //COSR1, COS2 // , BW
SPI_WriteData(0x31); //15 //COSR3, COS4 //CKV2, CKV2B
SPI_WriteData(0x19); //16 //COSR5, COS6 //STVR, FW
SPI_WriteData(0x88); //17 //COSR7, COS8
SPI_WriteData(0x88); //18 //COSR9, COS10
SPI_WriteData(0x88); //19 //COSR11, COS12
SPI_WriteData(0x88); //20 //COSR13, COS14
SPI_WriteData(0x88); //21 //COSR15, COS16
SPI_WriteData(0x88); //22 //COSR17, COS18
```

```
SPI_WriteComm(0xE0); //Gamma
SPI_WriteData(0x00); //1
SPI_WriteData(0x0A); //2
SPI_WriteData(0x0F); //3
SPI_WriteData(0x3B); //4
SPI_WriteData(0x3E); //5
SPI_WriteData(0x3F); //6
SPI_WriteData(0x21); //7
SPI_WriteData(0x43); //8
SPI_WriteData(0x08); //9
SPI_WriteData(0x0D); //10
SPI_WriteData(0x0E); //11
SPI_WriteData(0x11); //12
SPI_WriteData(0x14); //13
SPI_WriteData(0x11); //14
SPI_WriteData(0x13); //15
SPI_WriteData(0x0E); //16
SPI_WriteData(0x17); //17
SPI_WriteData(0x00); //18
SPI_WriteData(0x0A); //19
```

---

```
SPI_WriteData(0x0F); //20
SPI_WriteData(0x3B); //21
SPI_WriteData(0x3E); //22
SPI_WriteData(0x3F); //23
SPI_WriteData(0x21); //24
SPI_WriteData(0x43); //25
SPI_WriteData(0x08); //26
SPI_WriteData(0x0D); //27
SPI_WriteData(0x0E); //28
SPI_WriteData(0x11); //29
SPI_WriteData(0x14); //30
SPI_WriteData(0x11); //31
SPI_WriteData(0x13); //32
SPI_WriteData(0x0E); //33
SPI_WriteData(0x17); //34

SPI_WriteComm(0x11); // Sleep-Out
Delay(800);
SPI_WriteComm(0x29); // Display On
Delay(800);
```