

# 1A, Single-Input, Single-Cell LiFePO<sub>4</sub> Linear Battery Charger with 50mA LDO

Check for Samples: [bq25070](#)

## FEATURES

- Single Cell LiFePO<sub>4</sub> Charging Algorithm
- 30V Input Rating, With 10.5V Over-Voltage Protection (OVP)
- 50mA Integrated Low Dropout Linear Regulator (LDO)
- Programmable Charge Current Through Single Input Interface (CTRL)
- 7% Charge Current Regulation Accuracy
- Thermal Regulation and Protection
- Soft-Start Feature to Reduce Inrush Current

- Battery NTC Monitoring
- Charging Status Indication
- Available in Small 2mm × 3mm 10 Pin SON Package

## APPLICATIONS

- Smart Phones
- Mobile Phones
- Portable Media Players
- Low Power Handheld Devices

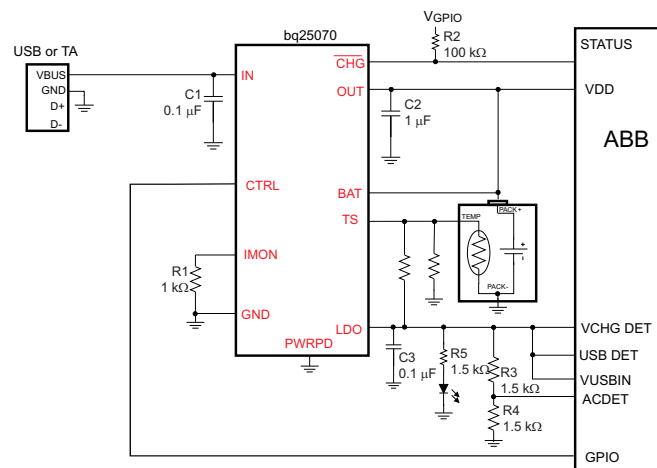
## DESCRIPTION

The bq25070 is a highly integrated LiFePO<sub>4</sub> linear battery charger targeted at space-limited portable applications. It operates from either a USB port or AC Adapter and charges a single-cell LiFePO<sub>4</sub> battery with up to 1A of charge current. The 30V input voltage range with input over-voltage protections supports low-cost unregulated adapters.

The bq25070 has a single power output that charges the battery and powers the system. The charge current is programmable up to 1A using the CTRL input. Additionally, a 4.9V ±10% 50mA LDO is integrated into the IC for supplying low power external circuitry.

The LiFePO<sub>4</sub> charging algorithm removes the constant voltage mode control usually present in Li-Ion battery charge cycles. Instead, the battery is fastcharged to the overcharge voltage and then allowed to relax to a lower float charge voltage threshold. The removal of the constant voltage control reduces charge time significantly. During the charge cycle, an internal control loop monitors the IC junction temperature and reduces the charge current if an internal temperature threshold is exceeded. The charger power stage and charge current sense functions are fully integrated. The charger function has high accuracy current and voltage regulation loops, and charge status display.

## APPLICATION SCHEMATIC



Please be aware that an important notice concerning availability, standard warranty, and use in critical applications of Texas Instruments semiconductor products and disclaimers thereto appears at the end of this data sheet.



These devices have limited built-in ESD protection. The leads should be shorted together or the device placed in conductive foam during storage or handling to prevent electrostatic damage to the MOS gates.

### ORDERING INFORMATION<sup>(1)</sup>

PART NUMBER	I <sub>LIM(DEF)</sub>	V <sub>BAT(OVCH)</sub>	V <sub>BAT(FLOAT)</sub>	V <sub>OVP</sub>	V <sub>LDO</sub>	MARKING
bq25070DQCR	300 mA	3.7 V	3.5 V	10.5 V	4.9 V	QUS
bq25070DQCT	300 mA	3.7 V	3.5 V	10.5 V	4.9 V	QUS

(1) For the most current package and ordering information, see the Package Option Addendum at the end of this document, or visit the device product folder on ti.com ([www.ti.com](http://www.ti.com)),

### ABSOLUTE MAXIMUM RATINGS<sup>(1)</sup>

over operating free-air temperature range (unless otherwise noted)

		VALUE	UNIT
Input Voltage	IN (with respect to GND)	-0.3 to 30	V
	CTRL, TS (with respect to GND)	-0.3 to 7	V
Output Voltage	BAT, OUT, LDO, $\overline{\text{CHG}}$ , IMON (with respect to GND)	-0.3 to 7	V
Input Current (Continuous)	IN	1.2	A
Output Current (Continuous)	BAT	1.2	A
Output Current (Continuous)	LDO	100	mA
Output Sink Current	$\overline{\text{CHG}}$	5	mA
Junction temperature, T <sub>J</sub>		-40 to 150	°C
Storage temperature, T <sub>STG</sub>		-65 to 150	°C

(1) Stresses beyond those listed under *absolute maximum ratings* may cause permanent damage to the device. These are stress ratings only, and functional operation of the device at these or any other conditions beyond those indicated under *recommended operating conditions* is not implied. Exposure to absolute-maximum-rated conditions for extended periods may affect device reliability. All voltage values are with respect to the network ground terminal unless otherwise noted.

### THERMAL INFORMATION

THERMAL METRIC <sup>(1)</sup>		bq25070	UNITS
		SON	
		10 PINS	
$\theta_{JA}$	Junction-to-ambient thermal resistance <sup>(2)</sup>	58.7	°C/W
$\theta_{JCTop}$	Junction-to-case (top) thermal resistance <sup>(3)</sup>	3.9	

- (1) For more information about traditional and new thermal metrics, see the *IC Package Thermal Metrics* application report, [SPRA953](#).  
 (2) The junction-to-ambient thermal resistance under natural convection is obtained in a simulation on a JEDEC-standard, high-K board, as specified in JESD51-7, in an environment described in JESD51-2a.  
 (3) The junction-to-case (top) thermal resistance is obtained by simulating a cold plate test on the package top. No specific JEDEC-standard test exists, but a close description can be found in the ANSI SEMI standard G30-88.

### RECOMMENDED OPERATING CONDITIONS

		MIN	MAX	UNITS
V <sub>IN</sub>	IN voltage range	3.75 <sup>(1)</sup>	28	V
	IN operating voltage range	3.75 <sup>(1)</sup>	10.2	
I <sub>IN</sub>	Input current, IN		1	A
I <sub>OUT</sub>	Output Current in charge mode, OUT		1	A
T <sub>J</sub>	Junction Temperature	0	125	°C

(1) Charge current may be limited at low input voltages due to the dropout of the device.

## ELECTRICAL CHARACTERISTICS

Over junction temperature range  $0^{\circ}\text{C} \leq T_J \leq 125^{\circ}\text{C}$  and recommended supply voltage (unless otherwise noted)

PARAMETER		TEST CONDITIONS	MIN	TYP	MAX	UNITS
<b>INPUT</b>						
$V_{UVLO}$	Under-voltage lock-out	$V_{IN}: 0\text{ V} \rightarrow 4\text{ V}$	3.15	3.30	3.55	V
$V_{HYS-UVLO}$	Hysteresis on UVLO	$V_{IN}: 4\text{ V} \rightarrow 0\text{ V}$		250		mV
$V_{BATUVLO}$	Battery UVLO	$V_{BAT}$ rising	1.95	2.05	2.15	V
$V_{HYS-BUVLO}$	Hysteresis on BAT UVLO	$V_{BAT}$ falling		125		mV
$V_{IN-SLP}$	Valid input source threshold $V_{IN-SLP}$ above $V_{BAT}$	Input power good if $V_{IN} > V_{BAT} + V_{IN-SLP}$ $V_{BAT} = 3.6\text{ V}$ , $V_{IN}: 3.5\text{ V} \rightarrow 4\text{ V}$	30	75	150	mV
$V_{HYS-INSLP}$	Hysteresis on $V_{IN-SLP}$	$V_{BAT} = 3.6\text{ V}$ , $V_{IN}: 4\text{ V} \rightarrow 3.5\text{ V}$	18	32	54	mV
$t_{DGL(NO-IN)}$	Delay time, input power loss to charger turn-off	Time measured from $V_{IN}: 5\text{ V} \rightarrow 2.5\text{ V}$ 1 $\mu\text{s}$ fall-time		32		ms
$V_{OVP}$	Input over-voltage protection threshold	$V_{IN}: 5\text{ V} \rightarrow 11\text{ V}$	10.2	10.5	10.8	V
$V_{HYS-OVP}$	Hysteresis on OVP	$V_{IN}: 11\text{ V} \rightarrow 5\text{ V}$		100		mV
$t_{BLK(OVP)}$	Input over-voltage blanking time			100		$\mu\text{s}$
$t_{REC(OVP)}$	Input over-voltage recovery time	Time measured from $V_{IN}: 11\text{ V} \rightarrow 5\text{ V}$ 1 $\mu\text{s}$ fall-time to LDO = HI, $V_{BAT} = 3.5\text{ V}$		100		$\mu\text{s}$
<b>QUIESCENT CURRENT</b>						
$I_{BAT(PDWN)}$	Battery current into BAT, No input connected	$V_{IN} = 0\text{ V}$ , $\overline{V_{CHG}} = \text{High}$ , TS Enabled		120	150	$\mu\text{A}$
		$V_{IN} = 0\text{ V}$ , $\overline{V_{CHG}} = \text{Low}$ , TS Disabled, $T_J = 85^{\circ}\text{C}$			6	$\mu\text{A}$
$I_{IN(STDBY)}$	Standby current into IN pin	CTRL = HI, $V_{IN} = 5.5\text{ V}$			0.25	mA
		CTRL = HI, $V_{IN} \leq V_{OVP}$			0.5	
		CTRL = HI, $V_{IN} > V_{OVP}$			2	
ICC	Active supply current, IN pin	$V_{IN} = 6\text{ V}$ , No load on OUT pin, $V_{BAT} > V_{BAT(REG)}$ , IC enabled			3	mA
<b>BATTERY CHARGER FAST-CHARGE</b>						
$V_{BAT(REG)}$	Battery float charge voltage	$T_A = 0^{\circ}\text{C}$ to $125^{\circ}\text{C}$	3.465	3.5	3.535	V
		$T_A = 25^{\circ}\text{C}$	3.465	3.5	3.529	
$V_{BAT(OVCH)}$	Battery overcharge voltage threshold		3.62	3.7	3.78	V
$I_{IN(LIM)}$	Input Current Limit (selected by CTRL interface)	4 pulses on CTRL	87	93	100	mA
		5 pulses on CTRL	174	187	200	
		6 pulses on CTRL	261	280	300	
		7 pulses on CTRL	348	374	400	
		8 pulses on CTRL	435	467	500	
		9 pulses on CTRL	608	654	700	
		10 pulses on CTRL	739	794	850	
		11 pulses on CTRL	869	935	1000	
$V_{DO(IN-OUT)}$	$V_{IN} - V_{OUT}$	$V_{IN} = 3.5\text{ V}$ , $I_{OUT} = 0.75\text{ A}$		500	1400	mV
$K_{IMON}$	Input current monitor ratio	$K_{IMON} = I_{IMON} / I_{CHG}$ , $R_{IMON} = 1\text{k}\Omega$ , Current programmed using CTRL		1		mA / A
$V_{IMON(MAX)}$	Maximum IMON voltage	IMON open		1.2	1.25	V
	IMON Accuracy	$I_{IN} < 100\text{ mA}$	-25%		25%	
		$I_{IN} = 100\text{ mA}$ to $1\text{ A}$	-10%		10%	
<b>PRE-CHARGE AND CHARGE DONE</b>						
$V_{LOWV}$	Pre-charge to fast-charge transition threshold		2.4	2.5	2.6	V
$t_{DGL1(LOWV)}$	Deglintch time on pre-charge to fast-charge transition			25		ms
$t_{DGL2(LOWV)}$	Deglintch time on fast-charge to pre-charge transition			25		ms

## ELECTRICAL CHARACTERISTICS (continued)

Over junction temperature range  $0^{\circ}\text{C} \leq T_J \leq 125^{\circ}\text{C}$  and recommended supply voltage (unless otherwise noted)

PARAMETER		TEST CONDITIONS	MIN	TYP	MAX	UNITS
$I_{\text{PRECHARGE}}$	Precharge current to BAT during precharge mode	$V_{\text{BAT}} = 0 \text{ V to } 0.7 \text{ V}$	41.5	45	48.5	mA
<b>RECHARGE OR REFRESH</b>						
$V_{\text{RCH}}$	Recharge detection threshold	$V_{\text{BAT}}$ falling	3.1	3.3	3.5	V
$t_{\text{DGL(RCH)}}$	Deglintch time, recharge threshold detected	$V_{\text{BAT}}$ falling to New Charge Cycle		25		ms
<b>LDO</b>						
$V_{\text{LDO}}$	LDO Output Voltage	$V_{\text{IN}} = 5 \text{ V to } 10.5 \text{ V}$ , $I_{\text{LDO}} = 0 \text{ mA to } 50 \text{ mA}$	4.7	4.9	5.1	V
$I_{\text{LDO}}$	Maximum LDO Output Current		60			mA
$V_{\text{DO}}$	Dropout Voltage	$V_{\text{IN}} = 4.5\text{V}$ , $I_{\text{LDO}} = 50\text{mA}$		200	350	mV
<b>CTRL INTERFACE</b>						
$t_{\text{CTRL\_DGL}}$	CTRL Deglitch timer		5			ms
$t_{\text{CTRL\_LATCH}}$	CTRL Latch timer		2			ms
$t_{\text{HI\_MIN}}$	High Duration on CTRL		50		1000	$\mu\text{s}$
$t_{\text{LO\_MIN}}$	Low Time Duration on CTRL		50		1000	$\mu\text{s}$
$R_{\text{PULLDOWN}}$	CTRL Pulldown Resistor			260		k $\Omega$
<b>LOGIC LEVELS ON CTRL</b>						
$V_{\text{IL}}$	Logic LOW input voltage				0.4	V
$V_{\text{IH}}$	Logic HIGH input voltage		1.4			V
<b>BATTERY-PACK NTC MONITOR (TS)</b>						
$V_{\text{COLD}}$	TS Cold Threshold	$V_{\text{TS}}$ Rising	24.5	25	25.5	$\%V_{\text{LDO}}$
$V_{\text{CUTOFF}}$	TS Cold Cutoff Threshold	$V_{\text{TS}}$ Falling		1		$\%V_{\text{LDO}}$
$V_{\text{HOT}}$	TS Hot Threshold	$V_{\text{TS}}$ Falling	12	12.5	13	$\%V_{\text{LDO}}$
$V_{\text{HOT\_HYS}}$	TS Hot Cutoff Threshold	$V_{\text{TS}}$ Rising		1		$\%V_{\text{LDO}}$
$t_{\text{dgl(TS)}}$	Deglitch for TS Fault	Fault detected on TS to stop charge		25		ms
<b>CHG OUTPUT</b>						
$V_{\text{OL}}$	Output LOW voltage	$I_{\text{SINK}} = 1 \text{ mA}$			0.45	V
$I_{\text{IH}}$	Leakage current	$\overline{\text{CHG}} = 5 \text{ V}$			1	$\mu\text{A}$
$t_{\text{FLSH(TS)}}$	TS fault flash period	50% Duty Cycle, TS out of valid range		100		ms
<b>THERMAL REGULATION</b>						
$T_{\text{J(REG)}}$	Temperature Regulation Limit	$T_J$ rising		125		C
$T_{\text{J(OFF)}}$	Thermal shutdown temperature	$T_J$ rising		155		C
$T_{\text{J(OFF-HYS)}}$	Thermal shutdown hysteresis	$T_J$ falling		20		C

### TYPICAL CHARACTERISTICS

$V_{IN} = 5\text{ V}$ ,  $V_{BAT} = 3.2\text{ V}$ ,  $I_{CHG} = 280\text{ mA}$ , Typical Application Circuit

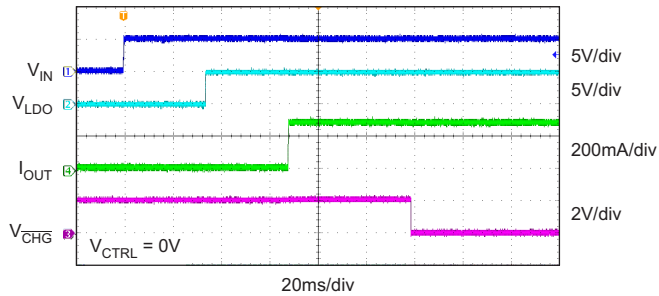


Figure 1. Adapter Plug-In With Battery Connected

G001

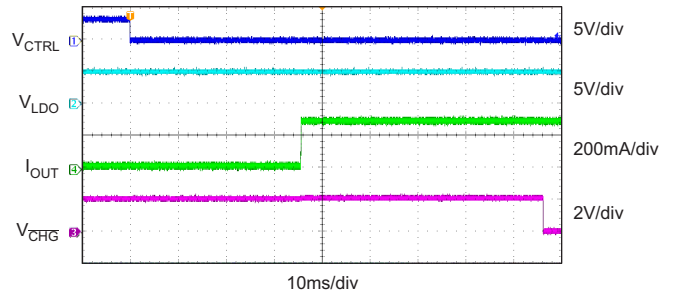


Figure 2. Charger Enable Using CTRL

G002

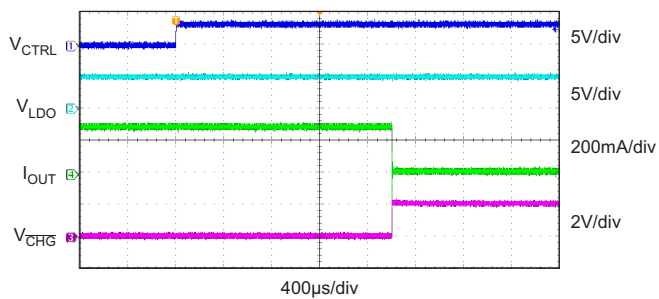


Figure 3. Charger Disable Using CTRL

G003

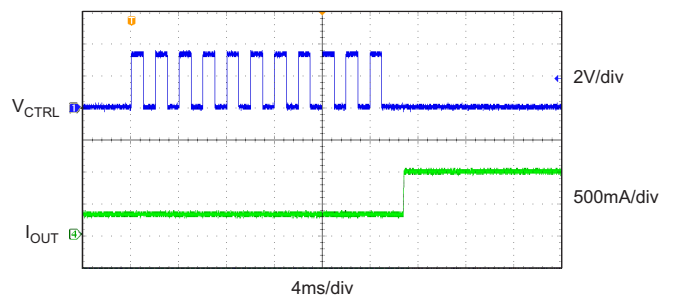


Figure 4. Default to 1A Transition Using CTRL

G004

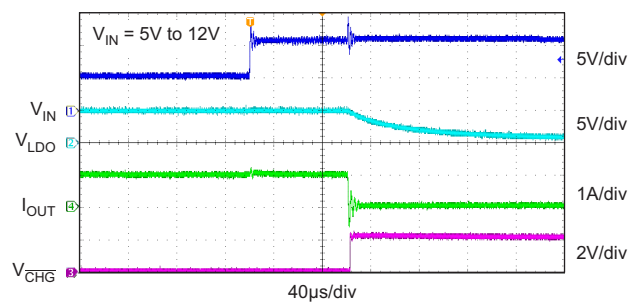


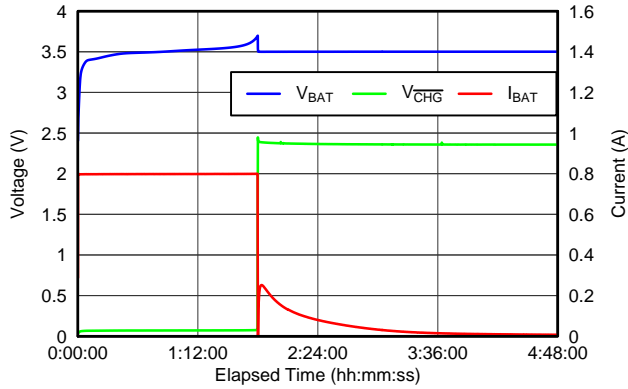
Figure 5. OVP Fault

G005

**TYPICAL CHARACTERISTICS (continued)**

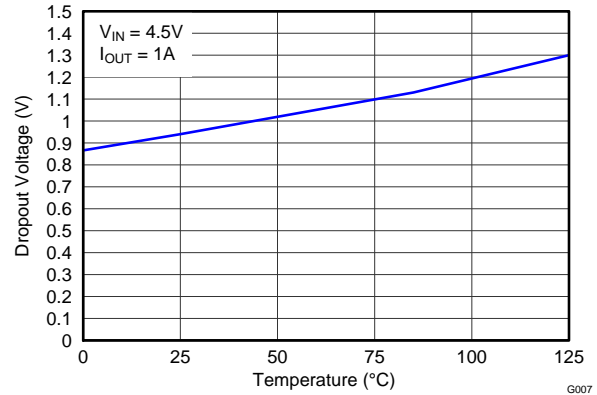
$V_{IN} = 5\text{ V}$ ,  $V_{BAT} = 3.2\text{ V}$ ,  $I_{CHG} = 280\text{ mA}$ , Typical Application Circuit

**VOLTAGE and CURRENT vs ELAPSED TIME**



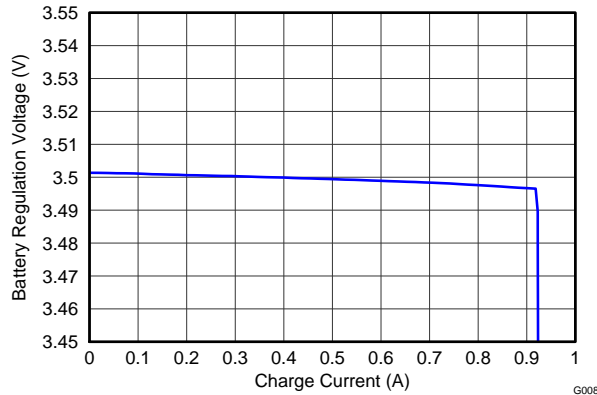
**Figure 6. Complete Charge Cycle**

**DROPOUT VOLTAGE vs TEMPERATURE**



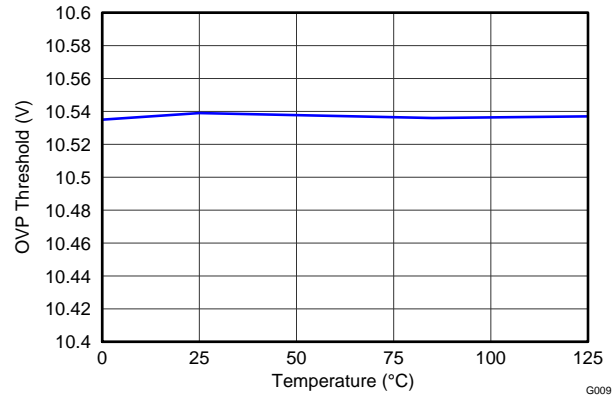
**Figure 7.**

**BATTERY REGULATION VOLTAGE vs CHARGE CURRENT**



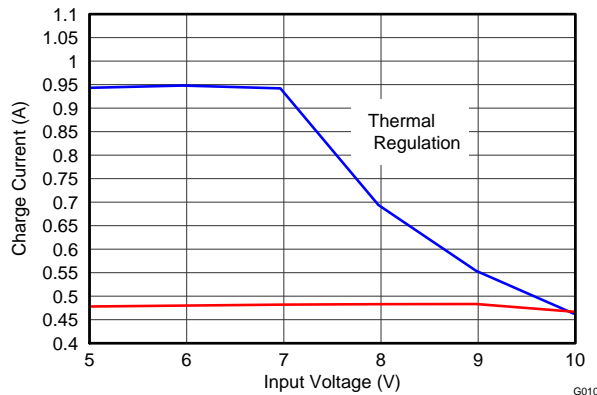
**Figure 8.**

**OVP THRESHOLD vs TEMPERATURE**



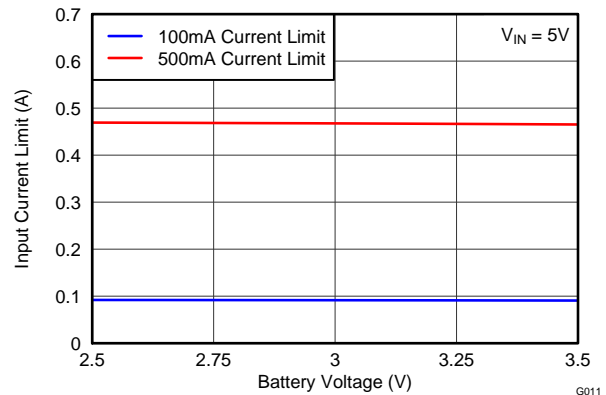
**Figure 9.**

**CHARGE CURRENT vs INPUT VOLTAGE**



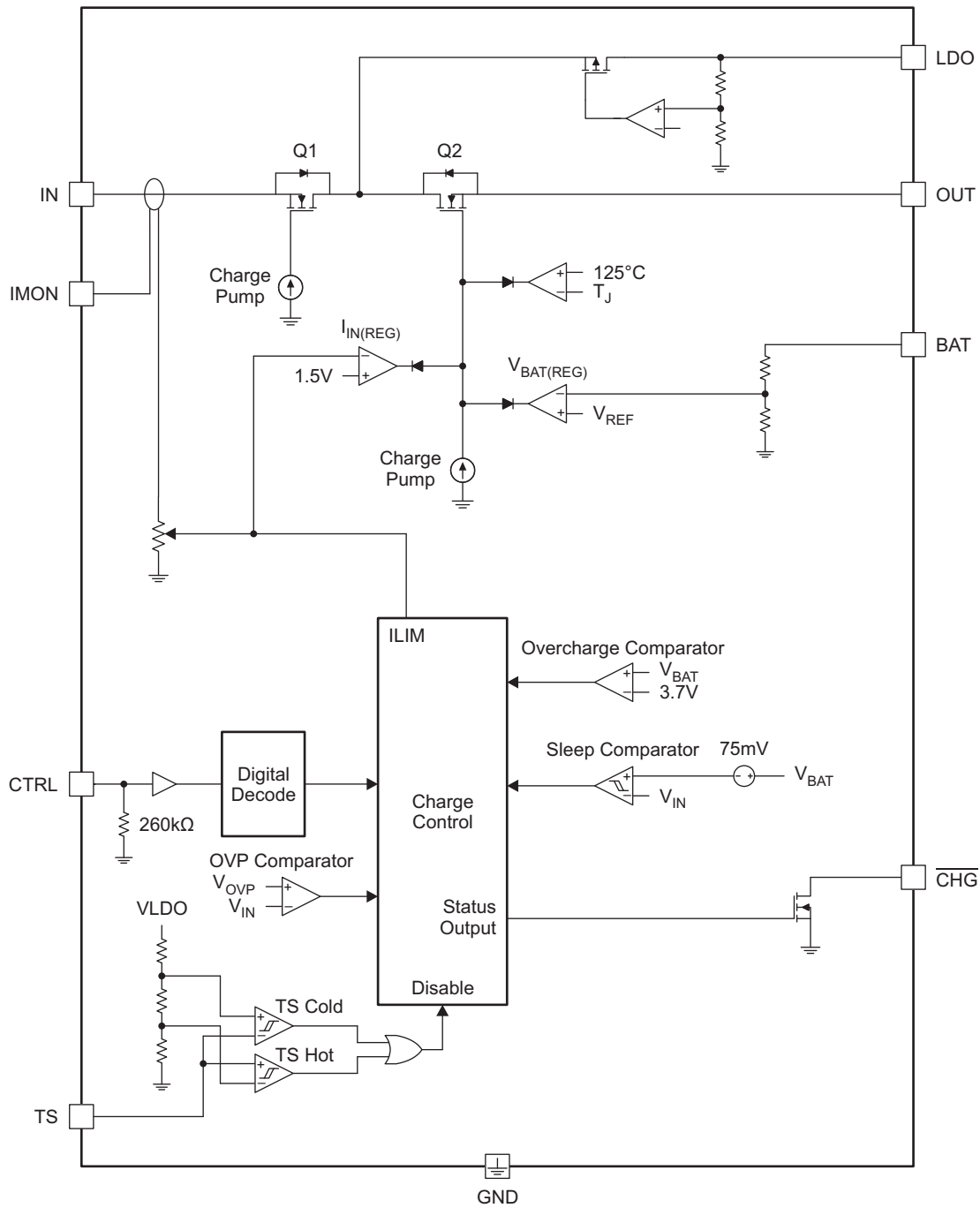
**Figure 10.**

**INPUT CURRENT LIMIT vs BATTERY VOLTAGE**

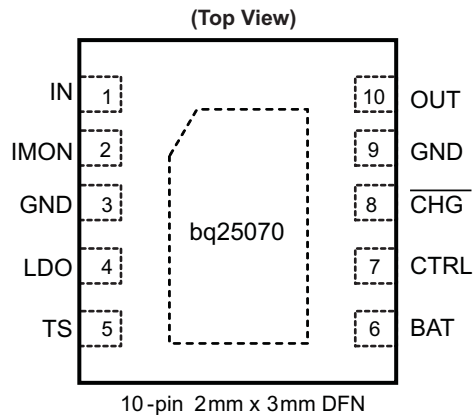


**Figure 11.**

SIMPLIFIED BLOCK DIAGRAM



## PIN CONFIGURATION



## PIN FUNCTIONS

PIN		I/O	DESCRIPTION
NAME	NO.		
IN	1	I	Input power supply. IN is connected to the external DC supply (AC adapter or USB port). Bypass IN to GND with at least a 0.1µF ceramic capacitor.
IMON	2	O	Current monitoring output. Connect a 1kΩ resistor from IMON to GND to monitor the input current. The voltage at IMON ranges from 0V to 1V which corresponds to an input current from 0A to 1A.
GND	3, 9	–	Ground terminal. Connect to the thermal pad and the ground plane of the circuit.
LDO	4	O	LDO output. LDO is regulated to 4.9V and drives up to 50mA. Bypass LDO to GND with a 0.1µF ceramic capacitor. LDO is enabled when $V_{UVLO} < V_{IN} < V_{OVP}$ .
TS	5	I	Battery pack NTC monitoring input. Connect a resistor divider from LDO to GND with TS connected to the center tap to set the charge temperature window. The battery pack NTC is connected in parallel with the bottom resistor of the divider. See the Applications Design section for details on the selecting the proper component values.
BAT	6	O	Battery connection output. BAT is the sense input for the battery. Connect BAT and OUT to the battery and bypass to GND with a 1µF ceramic capacitor.
CTRL	7	I	Single-input interface Input. Drive CTRL with pulses to enable/disable the device, enable/disable $V_{IN-DPM}$ , and select current limits. See the interface section for details on using the CTRL interface.
$\overline{CHG}$	8	O	Charge status indicator open-drain output. $\overline{CHG}$ is pulled low while the device is charging the battery. $\overline{CHG}$ goes high impedance when the battery is fully charged.
OUT	10	O	System output connection. Connect OUT and BAT together. Bypass the OUT and BAT connection to GND with a 1µF ceramic capacitor.
Thermal PAD	Pad	–	There is an internal electrical connection between the exposed thermal pad and the GND pin of the device. The thermal pad must be connected to the same potential as the GND pin on the printed circuit board. Do not use the thermal pad as the primary ground input for the device. GND pin must be connected to ground at all times.



APPLICATIONS CIRCUITS

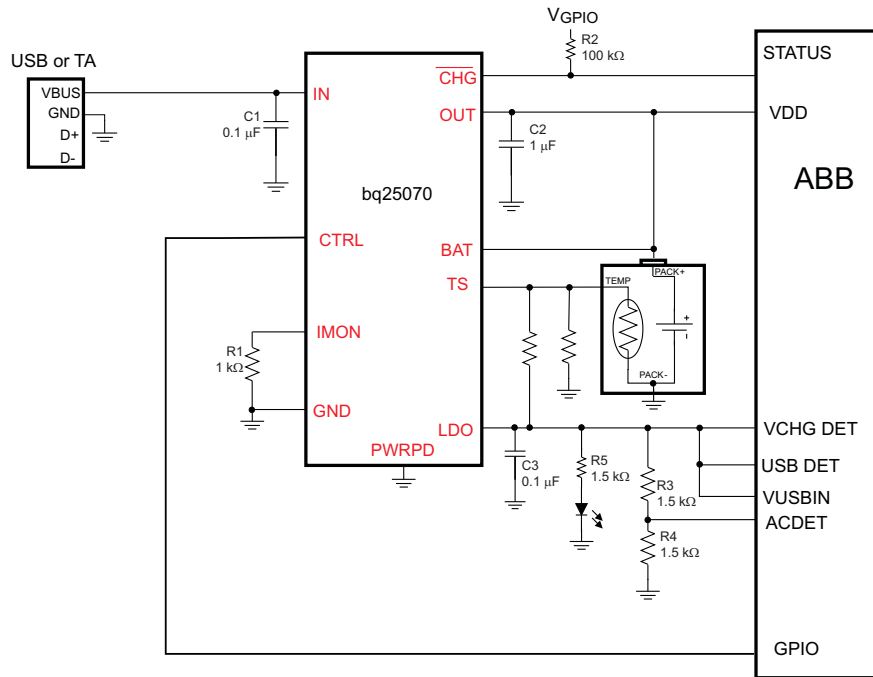


Figure 12. bq25070 Typical Application Circuit

## DETAILED FUNCTIONAL DESCRIPTION

The bq25070 is a highly integrated LiFePO<sub>4</sub> linear battery charger targeted at space-limited portable applications. It operates from either a USB port or AC Adapter and charges a single-cell LiFePO<sub>4</sub> battery with up to 1A of charge current. The 30V input voltage range with input over-voltage protections supports low-cost unregulated adapters.

The LiFePO<sub>4</sub> charging algorithm removes the constant voltage mode control usually present in Li-Ion battery charge cycles. Instead, the battery is charged with the fastcharge current to the overcharge voltage and then allowed to relax to a lower float charge voltage threshold. The removal of the constant voltage control reduces charge time significantly. During the charge cycle, an internal control loop monitors the IC junction temperature and reduces the charge current if an internal temperature threshold is exceeded. The charger power stage and charge current sense functions are fully integrated. The charger function has high accuracy voltage and current regulation loops, and charge status display.

### CHARGING OPERATION

The bq25070 uses a charge algorithm that is unique to LiFePO<sub>4</sub> chemistry cells. The constant voltage mode control usually present in Li-Ion battery charge cycles is eliminated. This dramatically decreases the charge time. When the bq25070 is enabled by CTRL, the battery voltage is monitored to verify which stage of charging must be used. When  $V_{BAT} < V_{LOWV}$ , the bq25070 charges in precharge mode; when  $V_{BAT} > V_{LOWV}$ , the normal charge cycle is used.

#### Charger Operation with Minimum System Voltage Mode Enabled

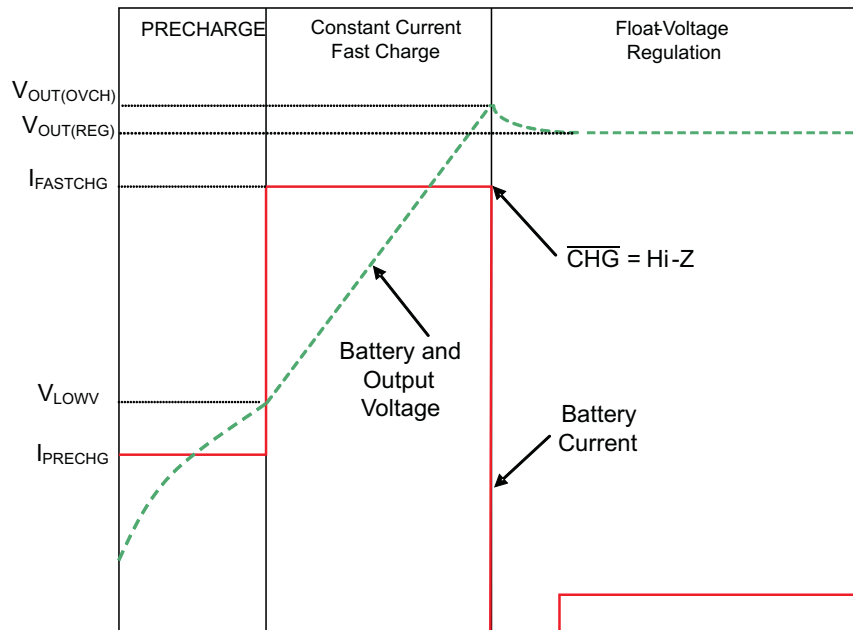


Figure 13. Typical Charging Cycle with Minimum System Voltage Enabled

#### Precharge Mode ( $V_{BAT} \leq V_{LOWV}$ )

The bq25070 enters precharge mode when  $V_{BAT} \leq V_{LOWV}$ . Upon entering precharge mode, the battery is charged with a 47.5mA current and  $\overline{CHG}$  goes low.

## Fast Charge Mode

Once  $V_{BAT} > V_{LOWV}$ , the bq25070 enters constant current (CC) mode where charge current is regulated using the internal MOSFETs between IN and OUT. The total current is shared between the output load and the battery. Once the battery voltage charges up to  $V_{BAT(OVCH)}$ , the **CHG** output goes high indicating the charge cycle is complete and the bq25070 switches the battery regulation voltage to  $V_{BAT(REG)}$ . The battery voltage is allowed to relax down to  $V_{BAT(REG)}$ . The charger remains enabled and regulates the output to  $V_{BAT(REG)}$ . If at any time the battery falls below  $V_{REC}$ , the charge cycle restarts.

## CHARGE CURRENT TRANSLATOR (IMON)

When the charger is enabled, internal circuits generate a current proportional to the charge current at the IMON input. The current out of IMON is 1/1000 ( $\pm 10\%$ ) of the charge current. This current, when applied to the external charge current programming resistor, R1 (Figure 12), generates an analog voltage that can be monitored by an external host to calculate the current sourced from BAT. Connect a 1k $\Omega$  resistor from IMON to GND. The voltage at IMON is calculated as:

$$V_{IMON} = I_{IN} \times 1 \frac{V}{A} \quad (1)$$

## INPUT OVER VOLTAGE PROTECTION

The bq25070 contains an input over voltage protection circuit that disables the LDO output and charging when the input voltage rises above  $V_{OVP}$ . This prevents damage from faulty adapters. The OVP circuitry contains an 115 $\mu$ s deglitch that prevents ringing on the input from line transients from tripping the OVP circuitry falsely. If an adapter with an output greater than  $V_{OVP}$  is plugged in, the IC completes soft-start power up and then shuts down if the voltage remains above  $V_{OVP}$  after 115 $\mu$ s. The LDO remains off and charging remains disabled until the input voltage falls below  $V_{OVP}$ .

## UNDER-VOLTAGE LOCKOUT (UVLO)

The bq25070 remains in power down mode when the input voltage is below the under-voltage lockout threshold ( $V_{UVLO}$ ). During this mode, the control input (CTRL) is ignored. The LDO, the charge FET connected between IN and OUT are off and the status output (CHG) is high impedance. Once the input voltage rises above  $V_{UVLO}$ , the internal circuitry is turned on and the normal operating procedures are followed.

## EXTERNAL NTC MONITORING (TS)

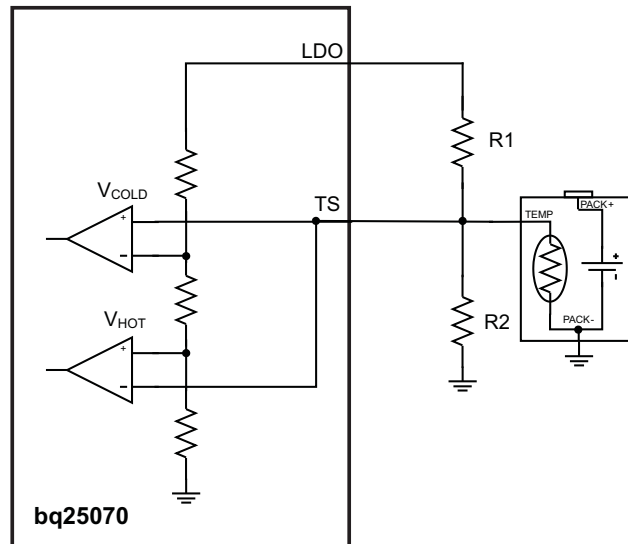
The bq25070 features a flexible, voltage based external battery pack temperature monitoring input. The TS input connects to the NTC thermistor in the battery pack to monitor battery temperature and prevent dangerous over-temperature conditions. During charging, the voltage at TS is continuously monitored. If, at any time, the voltage at TS is outside of the operating range ( $V_{COLD}$  to  $V_{HOT}$ ), charging is suspended. When the voltage measured at TS returns to within the operation window, charging is resumed. When charging is suspended due to a battery pack temperature fault, the CHG output remains low and continues to indicate charging.

The temperature thresholds are programmed using a resistor divider from LDO to GND with the NTC thermistor connected to the center tap from TS to GND. See Figure 14 for the circuit example. The value of R1 and R2 are calculated using the following equations:

$$R1 = \frac{-R2 \times RHOT \times (0.125 - 1)}{0.125 \times (R2 + RHOT)} \quad (2)$$

$$R2 = \frac{-RHOT \times RCOLD \times (0.125 - 0.250)}{RHOT \times 0.250 \times (0.125 - 1) + RCOLD \times 0.125 \times (1 - 0.250)} \quad (3)$$

RHOT is the expected thermistor resistance at the programmed hot threshold; RCOLD is the expected thermistor resistance at the programmed cold threshold.



For applications that do not require the TS monitoring function, set  $R1 = 490k\Omega$  and  $R2 = 100k\Omega$  to set the TS voltage at a valid level and maintain charging.

**Figure 14. NTC Monitoring Function**

### 50 mA LDO (LDO)

The LDO output of the bq25070 is a low dropout linear regulator (LDO) that supplies up to 50mA while regulating to  $V_{LDO}$ . The LDO is active whenever the input voltage is above  $V_{UVLO}$  and below  $V_{OVP}$ . It is not affected by the CTRL input. The LDO output is used to power and protect circuitry such as USB transceivers from transients on the input supply.

### CHARGE STATUS INDICATOR ( $\overline{CHG}$ )

The bq25070 contains an open drain  $\overline{CHG}$  output that indicates when charge cycles and faults. When charging a battery in precharge or fastcharge mode, the  $\overline{CHG}$  output is pulled to GND. Once the BAT output reaches the overcharge voltage threshold,  $\overline{CHG}$  goes high impedance to signal the battery is fully charged. The  $\overline{CHG}$  output goes low during battery recharge cycles to signal the host.

Additionally,  $\overline{CHG}$  notifies the host if a NTC temperature fault has occurred.  $\overline{CHG}$  pulses with a period of 100ms and a 50% duty cycle if a TS faults occurs. Connect  $\overline{CHG}$  to the required logic level voltage through a  $1k\Omega$  to  $100k\Omega$  resistor to use the signal with a microprocessor.  $I_{CHG}$  must be below 5mA.

The IC monitors the CHG pin when no input is connected to verify if the system circuitry is active. If the voltage at CHG is logic being drive low when no input is connected, the TS circuit is turned off for a low quiescent current state. Once the voltage at CHG increases above logic high, the TS circuit is turned on.

### SINGLE INPUT INTERFACE (CTRL)

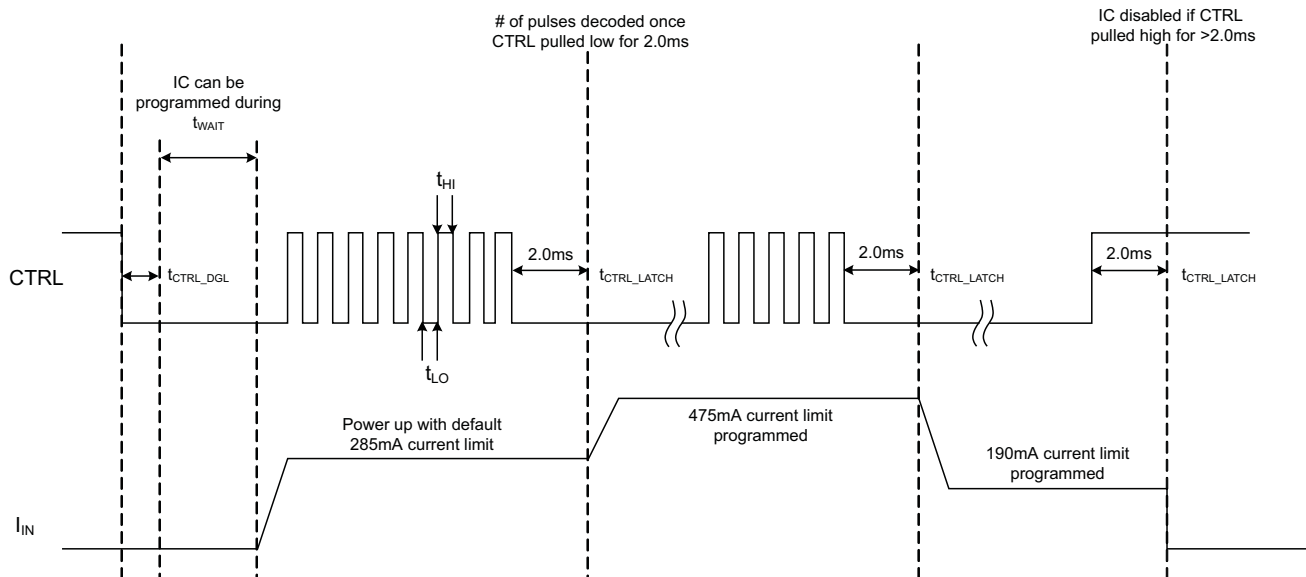
CTRL is used to enable/disable the device as well as select the input current limit, enable/disable charge, extend the TS operation range and disable  $V_{IN}$ -DPM mode. CTRL is pulled low to enable the device. After the  $50\mu s$  deglitch expires, the IC enters the 32ms WAIT state. CTRL may be used to program the bq25070 during this time. Once  $t_{WAIT}$  expires, the IC starts up. If no command is sent to CTRL during  $t_{WAIT}$ , the IC starts up with a default 285mA current limit.

Programming the different modes is done by pulsing the CTRL input. See [Table 1](#) for a map of the different modes. The width of the CTRL pulses is unimportant as long as they are between  $50\mu s$  and  $1000\mu s$  long. The time between pulses must be between  $50\mu s$  and  $1000\mu s$  to be properly read. Once CTRL is held low for 2ms, the number of pulses is passed to the control logic and decoded and then the mode changes. To ensure proper operation, do not send more than 16 pulses in one programming cycle.

**Table 1. Pulse Counting Map for CTRL Interface**

# of Pulses	Current Limit
1	No Change
2	No Change
3	No Change
4	93 mA
5	187 mA
6	280 mA
7	374 mA
8	467 mA
9	654 mA
10	794 mA
11	935 mA
>11	No Change

If, at any time, the CTRL input is held high for more than 2ms, the IC is disabled. When disabled, charging is suspended and the bq25070 input quiescent current is reduced.



**Figure 15. CTRL Timing Diagram**

## THERMAL REGULATION AND THERMAL SHUTDOWN

The bq25070 contains a thermal regulation loop that monitors the die temperature continuously. If the temperature exceeds  $T_{J(REG)}$ , the device automatically reduces the charging current to prevent the die temperature from increasing further. In some cases, the die temperature continues to rise despite the operation of the thermal loop, particularly under high  $V_{IN}$  conditions. If the die temperature increases to  $T_{J(OFF)}$ , the IC is turned off. Once the device die temperature cools by  $T_{J(OFF-HYS)}$ , the device turns on and returns to thermal regulation. Continuous over-temperature conditions result in the pulsing of the load current. If the junction temperature of the device exceeds  $T_{J(OFF)}$ , the charge FET is turned off. The FET is turned back on when the junction temperature falls below  $T_{J(OFF)} - T_{J(OFF-HYS)}$ .

Note that these features monitor the die temperature of the bq25070. This is not synonymous with ambient temperature. Self heating exists due to the power dissipated in the IC because of the linear nature of the battery charging algorithm.

## APPLICATION INFORMATION

### SELECTION OF INPUT/OUTPUT CAPACITORS

In most applications, all that is needed is a high-frequency decoupling capacitor on the input power pin. For normal charging applications, a 0.1µF ceramic capacitor, placed in close proximity to the IN pin and GND pad works best. In some applications, depending on the power supply characteristics and cable length, it may be necessary to increase the input filter capacitor to avoid exceeding the OVP voltage threshold during adapter hot plug events where the ringing exceeds the deglitch time.

The charger in the bq25070 requires a capacitor from OUT to GND for loop stability. Connect a 1µF ceramic capacitor from BAT to GND close to the pins for best results. More output capacitance may be required to minimize the output droop during large load transients.

The LDO also requires an output capacitor for loop stability. Connect a 0.1µF ceramic capacitor from LDO to GND close to the pins. For improved transient response, this capacitor may be increased.

### THERMAL CONSIDERATIONS

The bq25070 is packaged in a thermally enhanced QFN package. The package includes a thermal pad to provide an effective thermal contact between the IC and the printed circuit board (PCB). Full PCB design guidelines for this package are provided in the application note entitled: *QFN/SON PCB Attachment Application Note (SLUA271)*.

The most common measure of package thermal performance is thermal impedance ( $\theta_{JA}$ ) measured (or modeled) from the chip junction to the air surrounding the package surface (ambient). The mathematical expression for  $\theta_{JA}$  is:

Where:

$$\theta_{JA} = \frac{T_J - T_A}{P_D} \quad (4)$$

$T_J$  = chip junction temperature

$T_A$  = ambient temperature

$P_D$  = device power dissipation

Factors that can greatly influence the measurement and calculation of  $\theta_{JA}$  include:

- Whether or not the device is board mounted
- Trace size, composition, thickness, and geometry
- Orientation of the device (horizontal or vertical)
- Volume of the ambient air surrounding the device under test and airflow
- Whether other surfaces are in close proximity to the device being tested

The device power dissipation,  $P_D$ , is a function of the charge rate and the voltage drop across the internal PowerFET. It can be calculated from the following equation when a battery pack is being charged:

$$P_D = (V_{IN} - V_{OUT}) \times I_{OUT}$$

Due to the charge profile of LiFePO<sub>4</sub> batteries the maximum power dissipation is typically seen at the beginning of the charge cycle when the battery voltage is at its lowest. See the charging profile, [Figure 13](#). If the board thermal design is not adequate the programmed fast charge rate current may not be achieved under maximum input voltage and minimum battery voltage, as the thermal loop can be active, effectively reducing the charge current to avoid excessive IC junction temperature.

### PCB LAYOUT CONSIDERATIONS

It is important to pay special attention to the PCB layout. The following provides some guidelines:

- To obtain optimal performance, the decoupling capacitor from IN to GND (thermal pad) and the output filter capacitors from OUT to GND (thermal pad) should be placed as close as possible to the bq25070, with short trace runs to both IN, OUT and GND (thermal pad).

- All low-current GND connections should be kept separate from the high-current charge or discharge paths from the battery. Use a single-point ground technique incorporating both the small signal ground path and the power ground path.
- The high current charge paths into IN pin and from the OUT pin must be sized appropriately for the maximum charge current in order to avoid voltage drops in these traces.
- The bq25070 is packaged in a thermally enhanced SON package. The package includes a thermal pad to provide an effective thermal contact between the IC and the printed circuit board (PCB); this thermal pad is also the main ground connection for the device. Connect the thermal pad to the PCB ground connection. Full PCB design guidelines for this package are provided in the application note entitled: *QFN/SON PCB Attachment Application Note* ([SLUA271](#)).

**PACKAGING INFORMATION**

Orderable Device	Status (1)	Package Type	Package Drawing	Pins	Package Qty	Eco Plan (2)	Lead/Ball Finish	MSL Peak Temp (3)	Op Temp (°C)	Top-Side Markings (4)	Samples
BQ25070DQCR	ACTIVE	WSO	DQC	10	3000	Green (RoHS & no Sb/Br)	CU NIPDAU	Level-2-260C-1 YEAR	-40 to 85	QUS	<a href="#">Samples</a>
BQ25070DQCT	ACTIVE	WSO	DQC	10	250	Green (RoHS & no Sb/Br)	CU NIPDAU	Level-2-260C-1 YEAR	-40 to 85	QUS	<a href="#">Samples</a>

(1) The marketing status values are defined as follows:

**ACTIVE:** Product device recommended for new designs.

**LIFEBUY:** TI has announced that the device will be discontinued, and a lifetime-buy period is in effect.

**NRND:** Not recommended for new designs. Device is in production to support existing customers, but TI does not recommend using this part in a new design.

**PREVIEW:** Device has been announced but is not in production. Samples may or may not be available.

**OBSOLETE:** TI has discontinued the production of the device.

(2) Eco Plan - The planned eco-friendly classification: Pb-Free (RoHS), Pb-Free (RoHS Exempt), or Green (RoHS & no Sb/Br) - please check <http://www.ti.com/productcontent> for the latest availability information and additional product content details.

**TBD:** The Pb-Free/Green conversion plan has not been defined.

**Pb-Free (RoHS):** TI's terms "Lead-Free" or "Pb-Free" mean semiconductor products that are compatible with the current RoHS requirements for all 6 substances, including the requirement that lead not exceed 0.1% by weight in homogeneous materials. Where designed to be soldered at high temperatures, TI Pb-Free products are suitable for use in specified lead-free processes.

**Pb-Free (RoHS Exempt):** This component has a RoHS exemption for either 1) lead-based flip-chip solder bumps used between the die and package, or 2) lead-based die adhesive used between the die and leadframe. The component is otherwise considered Pb-Free (RoHS compatible) as defined above.

**Green (RoHS & no Sb/Br):** TI defines "Green" to mean Pb-Free (RoHS compatible), and free of Bromine (Br) and Antimony (Sb) based flame retardants (Br or Sb do not exceed 0.1% by weight in homogeneous material)

(3) MSL, Peak Temp. -- The Moisture Sensitivity Level rating according to the JEDEC industry standard classifications, and peak solder temperature.

(4) Multiple Top-Side Markings will be inside parentheses. Only one Top-Side Marking contained in parentheses and separated by a "~" will appear on a device. If a line is indented then it is a continuation of the previous line and the two combined represent the entire Top-Side Marking for that device.

**Important Information and Disclaimer:** The information provided on this page represents TI's knowledge and belief as of the date that it is provided. TI bases its knowledge and belief on information provided by third parties, and makes no representation or warranty as to the accuracy of such information. Efforts are underway to better integrate information from third parties. TI has taken and continues to take reasonable steps to provide representative and accurate information but may not have conducted destructive testing or chemical analysis on incoming materials and chemicals. TI and TI suppliers consider certain information to be proprietary, and thus CAS numbers and other limited information may not be available for release.

In no event shall TI's liability arising out of such information exceed the total purchase price of the TI part(s) at issue in this document sold by TI to Customer on an annual basis.



## TAPE AND REEL INFORMATION



### QUADRANT ASSIGNMENTS FOR PIN 1 ORIENTATION IN TAPE



\*All dimensions are nominal

Device	Package Type	Package Drawing	Pins	SPQ	Reel Diameter (mm)	Reel Width W1 (mm)	A0 (mm)	B0 (mm)	K0 (mm)	P1 (mm)	W (mm)	Pin1 Quadrant
BQ25070DQCR	WSON	DQC	10	3000	180.0	8.4	2.25	3.25	1.05	4.0	8.0	Q1
BQ25070DQCT	WSON	DQC	10	250	180.0	8.4	2.25	3.25	1.05	4.0	8.0	Q1

**TAPE AND REEL BOX DIMENSIONS**


\*All dimensions are nominal

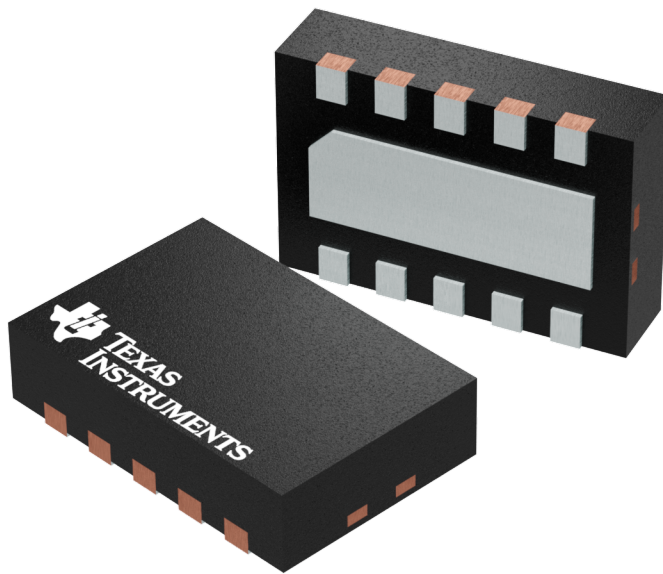
Device	Package Type	Package Drawing	Pins	SPQ	Length (mm)	Width (mm)	Height (mm)
BQ25070DQCR	WSON	DQC	10	3000	210.0	185.0	35.0
BQ25070DQCT	WSON	DQC	10	250	210.0	185.0	35.0

## GENERIC PACKAGE VIEW

DQC 10

WSO - 0.8 mm max height

PLASTIC SMALL OUTLINE - NO LEAD



Images above are just a representation of the package family, actual package may vary.  
Refer to the product data sheet for package details.

4209674/B

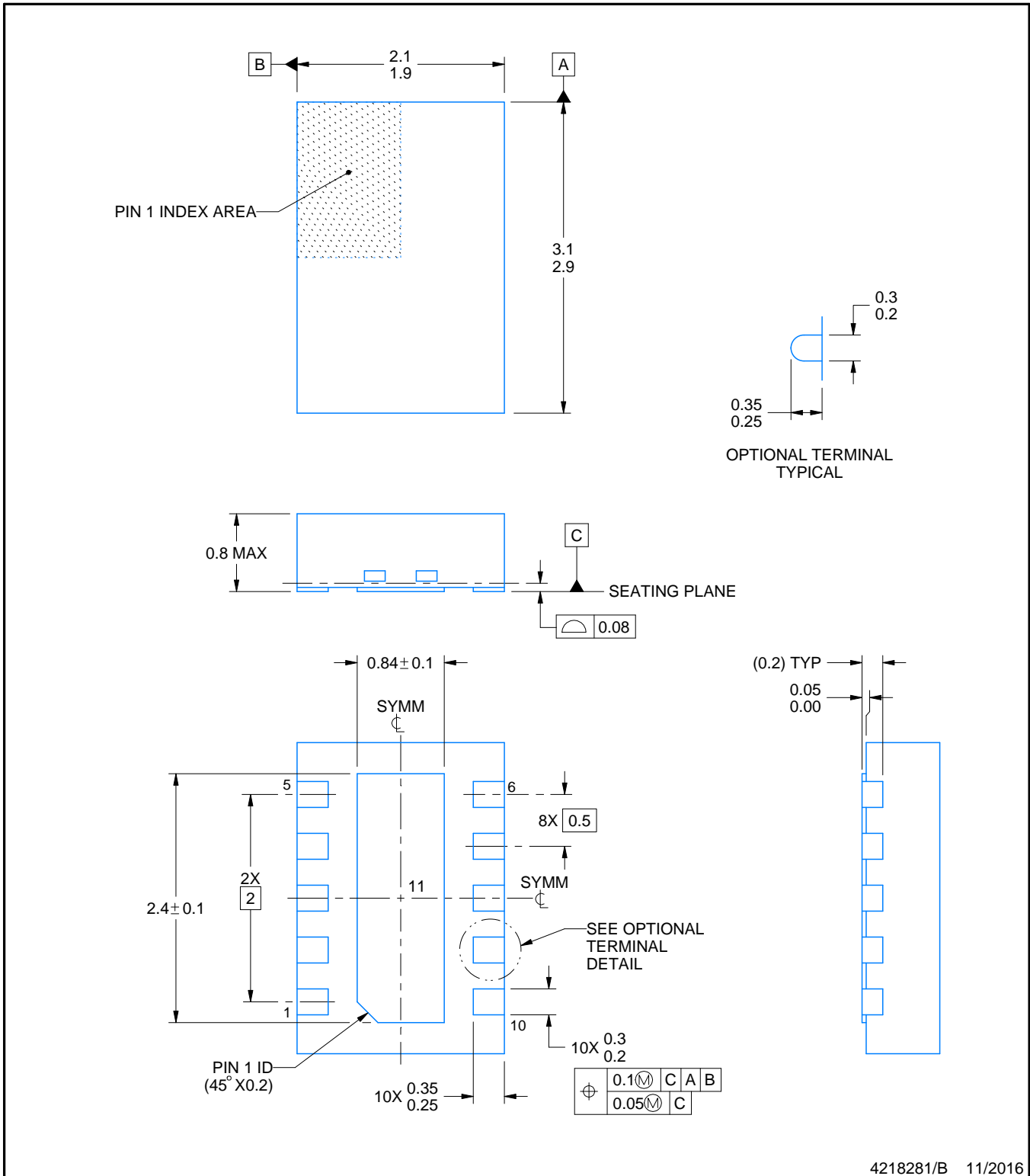
# DQC0010A



# PACKAGE OUTLINE

## WSO - 0.8mm max height

PLASTIC SMALL OUTLINE - NO LEAD



4218281/B 11/2016

**NOTES:**

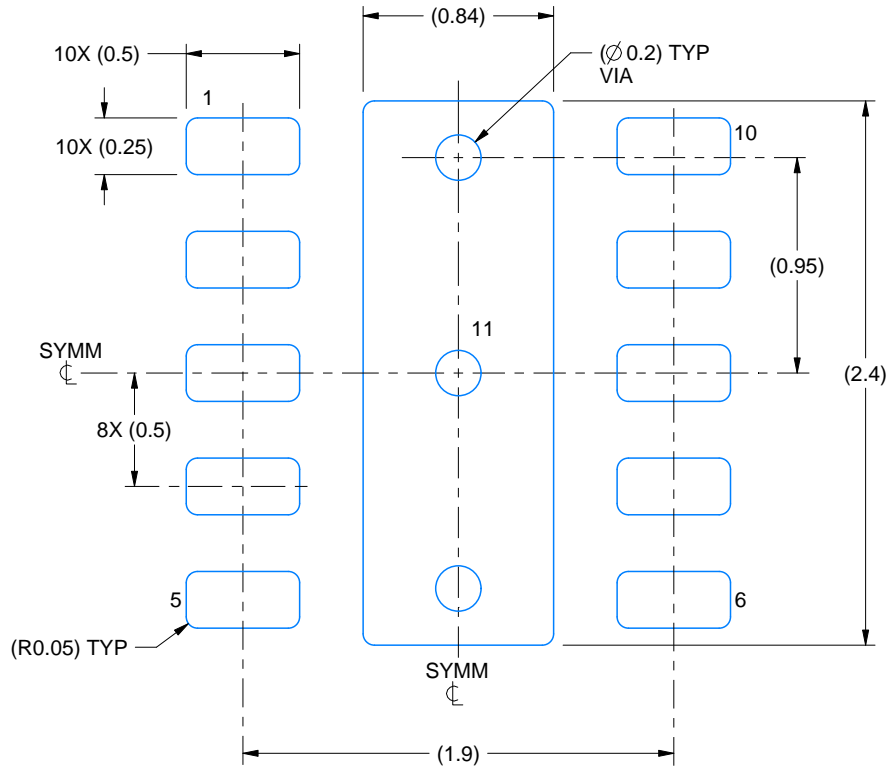
1. All linear dimensions are in millimeters. Any dimensions in parenthesis are for reference only. Dimensioning and tolerancing per ASME Y14.5M.
2. This drawing is subject to change without notice.
3. The package thermal pad must be soldered to the printed circuit board for thermal and mechanical performance.

# EXAMPLE BOARD LAYOUT

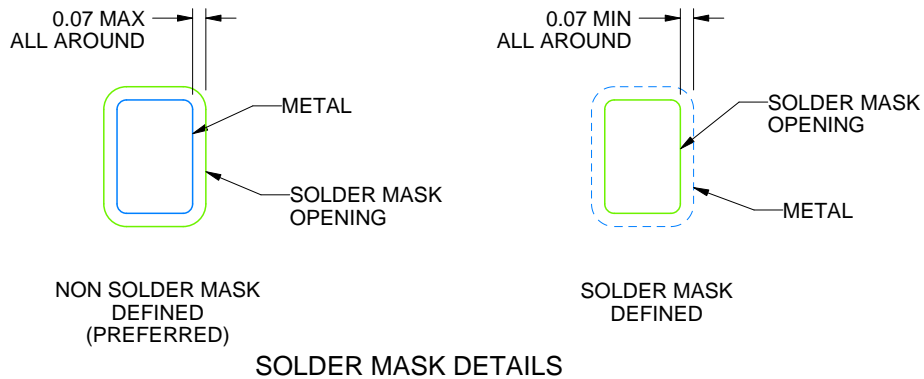
DQC0010A

WSN - 0.8mm max height

PLASTIC SMALL OUTLINE - NO LEAD



LAND PATTERN EXAMPLE  
SCALE: 30X



SOLDER MASK DETAILS

4218281/B 11/2016

NOTES: (continued)

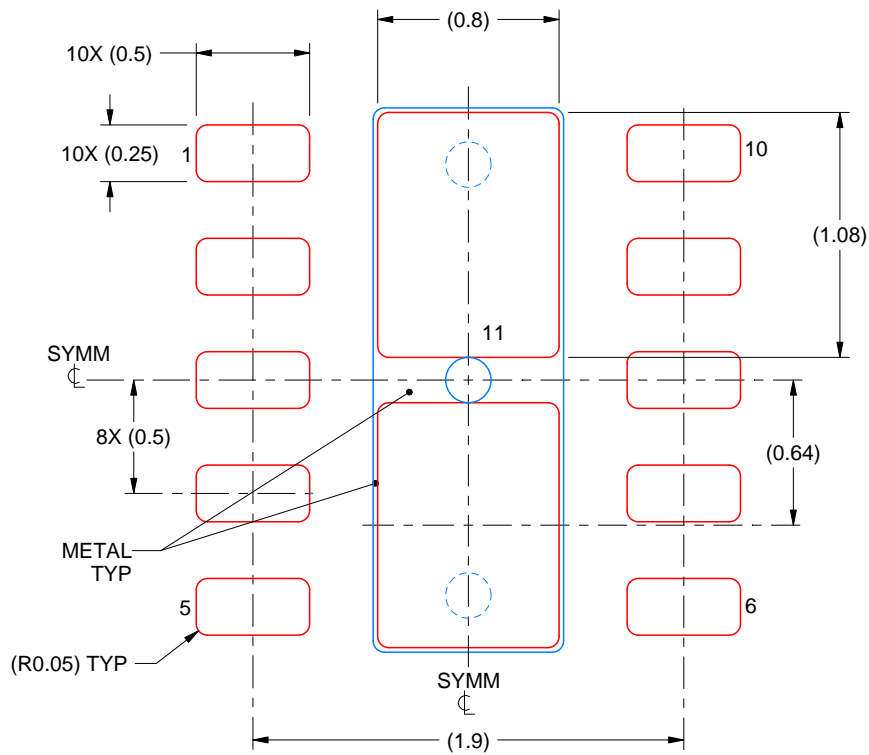
4. This package is designed to be soldered to a thermal pad on the board. For more information, see Texas Instruments literature number SLUA271 ([www.ti.com/lit/sluea271](http://www.ti.com/lit/sluea271)).
5. Vias are optional depending on application, refer to device data sheet. If any vias are implemented, refer to their locations shown on this view. It is recommended that vias under paste be filled, plugged or tented.

# EXAMPLE STENCIL DESIGN

DQC0010A

WSN - 0.8mm max height

PLASTIC SMALL OUTLINE - NO LEAD



SOLDER PASTE EXAMPLE  
BASED ON 0.125 mm THICK STENCIL

EXPOSED PAD 11:  
86% PRINTED SOLDER COVERAGE BY AREA UNDER PACKAGE  
SCALE: 30X

4218281/B 11/2016

NOTES: (continued)

6. Laser cutting apertures with trapezoidal walls and rounded corners may offer better paste release. IPC-7525 may have alternate design recommendations.

## IMPORTANT NOTICE

Texas Instruments Incorporated (TI) reserves the right to make corrections, enhancements, improvements and other changes to its semiconductor products and services per JESD46, latest issue, and to discontinue any product or service per JESD48, latest issue. Buyers should obtain the latest relevant information before placing orders and should verify that such information is current and complete.

TI's published terms of sale for semiconductor products (<http://www.ti.com/sc/docs/stdterms.htm>) apply to the sale of packaged integrated circuit products that TI has qualified and released to market. Additional terms may apply to the use or sale of other types of TI products and services.

Reproduction of significant portions of TI information in TI data sheets is permissible only if reproduction is without alteration and is accompanied by all associated warranties, conditions, limitations, and notices. TI is not responsible or liable for such reproduced documentation. Information of third parties may be subject to additional restrictions. Resale of TI products or services with statements different from or beyond the parameters stated by TI for that product or service voids all express and any implied warranties for the associated TI product or service and is an unfair and deceptive business practice. TI is not responsible or liable for any such statements.

Buyers and others who are developing systems that incorporate TI products (collectively, "Designers") understand and agree that Designers remain responsible for using their independent analysis, evaluation and judgment in designing their applications and that Designers have full and exclusive responsibility to assure the safety of Designers' applications and compliance of their applications (and of all TI products used in or for Designers' applications) with all applicable regulations, laws and other applicable requirements. Designer represents that, with respect to their applications, Designer has all the necessary expertise to create and implement safeguards that (1) anticipate dangerous consequences of failures, (2) monitor failures and their consequences, and (3) lessen the likelihood of failures that might cause harm and take appropriate actions. Designer agrees that prior to using or distributing any applications that include TI products, Designer will thoroughly test such applications and the functionality of such TI products as used in such applications.

TI's provision of technical, application or other design advice, quality characterization, reliability data or other services or information, including, but not limited to, reference designs and materials relating to evaluation modules, (collectively, "TI Resources") are intended to assist designers who are developing applications that incorporate TI products; by downloading, accessing or using TI Resources in any way, Designer (individually or, if Designer is acting on behalf of a company, Designer's company) agrees to use any particular TI Resource solely for this purpose and subject to the terms of this Notice.

TI's provision of TI Resources does not expand or otherwise alter TI's applicable published warranties or warranty disclaimers for TI products, and no additional obligations or liabilities arise from TI providing such TI Resources. TI reserves the right to make corrections, enhancements, improvements and other changes to its TI Resources. TI has not conducted any testing other than that specifically described in the published documentation for a particular TI Resource.

Designer is authorized to use, copy and modify any individual TI Resource only in connection with the development of applications that include the TI product(s) identified in such TI Resource. NO OTHER LICENSE, EXPRESS OR IMPLIED, BY ESTOPPEL OR OTHERWISE TO ANY OTHER TI INTELLECTUAL PROPERTY RIGHT, AND NO LICENSE TO ANY TECHNOLOGY OR INTELLECTUAL PROPERTY RIGHT OF TI OR ANY THIRD PARTY IS GRANTED HEREIN, including but not limited to any patent right, copyright, mask work right, or other intellectual property right relating to any combination, machine, or process in which TI products or services are used. Information regarding or referencing third-party products or services does not constitute a license to use such products or services, or a warranty or endorsement thereof. Use of TI Resources may require a license from a third party under the patents or other intellectual property of the third party, or a license from TI under the patents or other intellectual property of TI.

TI RESOURCES ARE PROVIDED "AS IS" AND WITH ALL FAULTS. TI DISCLAIMS ALL OTHER WARRANTIES OR REPRESENTATIONS, EXPRESS OR IMPLIED, REGARDING RESOURCES OR USE THEREOF, INCLUDING BUT NOT LIMITED TO ACCURACY OR COMPLETENESS, TITLE, ANY EPIDEMIC FAILURE WARRANTY AND ANY IMPLIED WARRANTIES OF MERCHANTABILITY, FITNESS FOR A PARTICULAR PURPOSE, AND NON-INFRINGEMENT OF ANY THIRD PARTY INTELLECTUAL PROPERTY RIGHTS. TI SHALL NOT BE LIABLE FOR AND SHALL NOT DEFEND OR INDEMNIFY DESIGNER AGAINST ANY CLAIM, INCLUDING BUT NOT LIMITED TO ANY INFRINGEMENT CLAIM THAT RELATES TO OR IS BASED ON ANY COMBINATION OF PRODUCTS EVEN IF DESCRIBED IN TI RESOURCES OR OTHERWISE. IN NO EVENT SHALL TI BE LIABLE FOR ANY ACTUAL, DIRECT, SPECIAL, COLLATERAL, INDIRECT, PUNITIVE, INCIDENTAL, CONSEQUENTIAL OR EXEMPLARY DAMAGES IN CONNECTION WITH OR ARISING OUT OF TI RESOURCES OR USE THEREOF, AND REGARDLESS OF WHETHER TI HAS BEEN ADVISED OF THE POSSIBILITY OF SUCH DAMAGES.

Unless TI has explicitly designated an individual product as meeting the requirements of a particular industry standard (e.g., ISO/TS 16949 and ISO 26262), TI is not responsible for any failure to meet such industry standard requirements.

Where TI specifically promotes products as facilitating functional safety or as compliant with industry functional safety standards, such products are intended to help enable customers to design and create their own applications that meet applicable functional safety standards and requirements. Using products in an application does not by itself establish any safety features in the application. Designers must ensure compliance with safety-related requirements and standards applicable to their applications. Designer may not use any TI products in life-critical medical equipment unless authorized officers of the parties have executed a special contract specifically governing such use. Life-critical medical equipment is medical equipment where failure of such equipment would cause serious bodily injury or death (e.g., life support, pacemakers, defibrillators, heart pumps, neurostimulators, and implantables). Such equipment includes, without limitation, all medical devices identified by the U.S. Food and Drug Administration as Class III devices and equivalent classifications outside the U.S.

TI may expressly designate certain products as completing a particular qualification (e.g., Q100, Military Grade, or Enhanced Product). Designers agree that it has the necessary expertise to select the product with the appropriate qualification designation for their applications and that proper product selection is at Designers' own risk. Designers are solely responsible for compliance with all legal and regulatory requirements in connection with such selection.

Designer will fully indemnify TI and its representatives against any damages, costs, losses, and/or liabilities arising out of Designer's non-compliance with the terms and provisions of this Notice.