

---

# **eSA Series**

**General Purpose  
Tiny Controller with  
Four-Channel Speech  
and Melody Synthesis**

# **Product Specification**

**Doc. Version 1.7**

**ELAN MICROELECTRONICS CORP.**

October 2006

---



**Trademark Acknowledgments:**

IBM is a registered trademark and PS/2 is a trademark of IBM.

Windows is a trademark of Microsoft Corporation.

ELAN and ELAN logo  are trademarks of ELAN Microelectronics Corporation.

Copyright © 2005~2006 by **ELAN Microelectronics Corporation**

**All Rights Reserved**

Printed in Taiwan

The contents of in this specification are subject to change without notice. ELAN Microelectronics assumes no responsibility concerning the accuracy, adequacy, or completeness of this specification. ELAN Microelectronics makes no commitment to update, or to keep current the information and material contained in this specification. Such information and material may change to conform to each confirmed order.

In no event shall ELAN Microelectronics be made responsible to any claims attributed to errors, omissions, or other inaccuracies in the information or material contained in this specification. ELAN Microelectronics shall not be liable for direct, indirect, special incidental, or consequential damages arising out of the use of such information or material.

The software (if any) described in this specification is furnished under a license or nondisclosure agreement, and may be used or copied only in accordance with the terms of such agreement.

ELAN Microelectronics products are not intended for use in life support appliances, devices, or systems. Use of ELAN Microelectronics product in such applications is not supported and is prohibited.

**NO PART OF THIS SPECIFICATION MAY BE REPRODUCED OR TRANSMITTED IN ANY FORM OR BY ANY MEANS WITHOUT THE EXPRESS WRITTEN PERMISSION OF ELAN MICROELECTRONICS.**



## **ELAN MICROELECTRONICS CORPORATION**

**Headquarters:**

No. 12, Innovation Road 1  
Hsinchu Science Park  
Hsinchu, TAIWAN 30077  
Tel: +886 3 563-9977  
Fax: +886 3 563-9966  
<http://www.emc.com.tw>

**Hong Kong:**

**Elan (HK) Microelectronics Corporation, Ltd.**  
Flat A, 19F., World Tech Centre  
95 How Ming Street, Kwun Tong  
Kowloon, HONG KONG  
Tel: +852 2723-3376  
Fax: +852 2723-7780  
[elanhk@emc.com.hk](mailto:elanhk@emc.com.hk)

**USA:**

**Elan Information Technology Group (U.S.A.)**  
1821 Saratoga Ave., Suite 250  
Saratoga, CA 95070  
U.S.A.  
Tel: +1 408 366-8225  
Fax: +1 408 366-8220

**Europe:**

**Elan Microelectronics Corp. (Europe)**  
Siewerdstrasse 105  
8050 Zurich, SWITZERLAND  
Tel: +41 43 299-4060  
Fax: +41 43 299-4079  
<http://www.elan-europe.com>

**Shenzhen:**

**Elan Microelectronics Shenzhen, Ltd.**  
SSMEC Bldg., 3F, Gaoxin S. Ave.  
Shenzhen Hi-Tech Industrial Park  
Shenzhen, Guandong, CHINA  
Tel: +86 755 2601-0565  
Fax: +86 755 2601-0500

**Shanghai:**

**Elan Microelectronics Shanghai, Ltd.**  
23/Bldg. #115 Lane 572, Bibo Road  
Zhangjiang Hi-Tech Park  
Shanghai, CHINA  
Tel: +86 21 5080-3866  
Fax: +86 21 5080-4600

# Contents

<b>1</b>	<b>General Description</b> .....	<b>1</b>
<b>2</b>	<b>Features</b> .....	<b>1</b>
<b>3</b>	<b>Selection Table</b> .....	<b>2</b>
<b>4</b>	<b>Application</b> .....	<b>3</b>
<b>5</b>	<b>Pin Description</b> .....	<b>3</b>
<b>6</b>	<b>Special Function Description</b> .....	<b>4</b>
6.1	Green Mode .....	4
6.2	Interrupt Mode .....	4
6.3	I/O Ports Description .....	4
6.3.1	Pull Low Structure of Ports 1, 2, and 3.....	5
<b>7</b>	<b>Electrical Characteristics</b> .....	<b>6</b>
7.1	Absolute Maximum Ratings.....	6
7.2	DC Characteristics .....	6
<b>8</b>	<b>Oscillator Frequency Deviation</b> .....	<b>7</b>
8.1	Oscillator Frequency vs. $R_{osc}$ ( $V_{DD}=3V$ ) .....	7
8.2	Oscillator Frequency vs. $V_{DD}$ (Normal Mode, $R_{osc}=56K\Omega$ ).....	7
8.3	Oscillator Frequency vs. $V_{DD}$ (Normal Mode, $R_{osc}=51K\Omega$ ).....	8
8.4	Oscillator Frequency vs. $V_{DD}$ (Green Mode, $R_{osc}=1M\Omega$ ).....	8
<b>9</b>	<b>Application Circuit</b> .....	<b>9</b>
9.1	R Oscillator in Normal Mode (Without Green Mode).....	9
9.2	Crystal Oscillator in Normal Mode (Without Green Mode) .....	10
9.3	R oscillator in Normal mode & Green mode.....	10
9.4	Crystal Oscillator in Normal Mode and R Oscillator in Green Mode.....	11



### Specification Revision History

Doc. Version	Revision Description	Date
1.4	Changed the operating voltage, added frequency deviation, application circuit, etc.	2005/05/09
1.5	Changed the standby current and auto optional oscillator select.	2005/11/09
1.6	Added new eSA010 to the series.	2006/05/12
1.7	<a href="#">Modified the eSA010 for the final version.</a>	<a href="#">2006/10/26</a>



## 1 General Description

The eSA Series IC's are 4-bit microcontroller based sound processors with audio function, like multi-channel speech and instrument playback. The series has a powerful 4-bit CPU that handles most of the speech and melody functions. Its four channels can be configured as speech or melody, and all the channels can be simultaneously played back. Speech synthesis is implemented by software. Wide range sampling rate and different volume levels are supported. The eSA Series provides real instrument waveform to obtain good quality melody, as well as one 4-bit input port, three 4-bit I/O ports (Port 2 is applicable to eSA010 only), and one 4-bit output port (applicable to eSA100 & eSA120 only). By programming through the microcontroller, applications, such as section combination, trigger mode, output control, keyboard matrix, and other logic functions are easily implemented.

In addition to Sleep mode, the eSA Series IC's also offer Green mode which allows reduced but continuous operation at very low power consumption. Normal operation resumes at a preset time. These enhanced versatile features allow users to create products with a wide variety of new fancy ideas.

---

## 2 Features

- System clock: 3.58 M Hz@2.2 volts ~ 5.1 volts
- Auto Optional crystal oscillator or RC oscillator (only RC oscillator is applicable to eSA010)
- Input/Output ports:
  - One Input port (P1) with software controlled pull-low resistor.
  - Three input /output ports (P2 ~ P4)  
P2 & P3 are software controlled with pull-low resistor and wake-up function (eSA010 has only one input/output port, P2)
  - One output port (P5) applicable to eSA100 & eSA120 only.
- Sleep mode to conserve power, less than 2 $\mu$ A@3V standby current
- Green mode for reduced but continuous operation at very low power consumption (less than 15 $\mu$ A@3V) (not supported for eSA010)
- 4 bits RISC type controller, each instruction takes 1 (90%) or 2 clocks
- 12 bits width per instruction, each instruction takes 1 (90%) or 2 words
- One interrupt entrance. Multiple interrupt sources.
- Total of six interrupts are available:
  - Four interrupts for speech/melody operation
  - One for timer
  - One external interrupt for general purpose (not supported for eSA010)

## eSA Series

General Purpose Tiny Controller with  
Four-Channel Speech and Melody Synthesis



- 32K words maximum program address (except for the eSA010 which has 20K words max., eSA015 which has 24K words max).
- Total of eight stacks
- 192 nibbles RAM
- Maximum of 4 channels can play simultaneously
- Each channel can be arbitrarily assigned as speech or melody channel
- Software PCM/ADPCM/ADPCM+ algorithm for speech synthesis, is transparent to users
- Instrument waveform that provides much better melody tone quality
- Flexible envelope control for melody
- Built-in hardware multiplier and mixer
- 128 steps volume control for each channel; 16 steps DA volume control for mixer output.
- Optional 8 bits PWM or 10 bits traditional current DA (only PWM is applicable for eSA010)
- 4 Flash with volume level options; 1/2, 1/4, 1/8/, & 1/16

### 3 Selection Table

The eSA Series integrates an extensive range of features, most of which are common to all devices, except for some distinctive features like Program Size, Program ROM, I/O count and Timer function. For user convenience in the choice of the most suitable product for their application, the following table is provided, which enumerates the main features of each device.

IC Type	Time (sec)	Stack	Program Size (words)	ROM (Bits)	RAM (Bits)	I/O (x4)	Cryst /Rst	IR	Channel	DA
eSA010	10	8	20K	20K × 16	192 × 4	P2	Rst only	Yes	4	PWM only
eSA015	15	8	24K	24K × 16	192 × 4	P1, P2, P3, P4	Yes	Yes	4	1
eSA020	20	8	32K	32K × 16	192 × 4	P1, P2, P3, P4	Yes	Yes	4	1
eSA030	30	8	32K	48K × 16	192 × 4	P1, P2, P3, P4	Yes	Yes	4	1
eSA040	40	8	32K	64K × 16	192 × 4	P1, P2, P3, P4	Yes	Yes	4	1
eSA065	65	8	32K	104K × 16	192 × 4	P1, P2, P3, P4	Yes	Yes	4	1
eSA080	80	8	32K	128K × 16	192 × 4	P1, P2, P3, P4	Yes	Yes	4	1
eSA100	100	8	32K	160K × 16	192 × 4	P1, P2, P3, P4, P5	Yes	Yes	4	1
eSA120	120	8	32K	192K × 16	192 × 4	P1, P2, P3, P4, P5	Yes	Yes	4	1



## 4 Application

- Musical Instrument toys and leisure products
- Musical Instrument keyboards
- Musical appliances
- Educational learning tools

## 5 Pin Description

Symbol	I/O	Function Description
OSCI	I	Crystal oscillator in / RC oscillator in (Normal mode)
OSCO	O	Crystal oscillator out / RC oscillator in (Green mode) (not supported for eSA010)
P1.0~3	I	Bits 0~3 of Port 1 (not supported for eSA010)
P2.0~3	I/O	Bits 0~3 of Port 2
P3.0~3	I/O	Bits 0~3 of Port 3 (not supported for eSA010)
P4.0~3	I/O	Bits 0~3 of Port 4 (not supported for eSA010)
P5.0~3	O	Bits 0~3 of Port 5 (only applicable for eSA100 & eSA120)
VO1A	O	PWM voice output/Traditional DA (only supports PWM for eSA010)
VO1B	O	PWM voice output
VDD0	I	For I/O, controller logic, oscillator circuit power
VSS0	I	For I/O, controller logic, oscillator circuit ground
RESETB	I	Reset pin (internal pull-high)
IRin	I	IR receiver pad
IRout	O	IR Transmit pad
VDD1	I	For PWM/DAC power
VSS1	I	For PWM/DAC ground
TEST	–	Test pin

## 6 Special Function Description

### 6.1 Green Mode

Green mode is a very useful feature for conserving power (see table below) and in extending the lifetime of batteries. With Green mode, it is possible to achieve reduced but continuous operation at very low power consumption (less than 15 $\mu$ A@3V), and to resume normal operation at a preset time.

Mode	Current Consumption	Suitable Usage Condition
Normal mode	maximum 3 mA@V <sub>DD</sub> =3V	Complex computing, scenario flow control, high power consumption
Green mode	maximum 15 $\mu$ A@V <sub>DD</sub> =3V	Long (preset) reduced but continuous operation at very low power consumption (not supported for eSA010)
Sleep mode	maximum 2 $\mu$ A@ V <sub>DD</sub> =3V	Sleep (no operation) & wake-up only to save power

### 6.2 Interrupt Mode

A total of six interrupts are available. Each interrupt can be enabled or disabled and the interrupt status can be checked by the corresponding flags.

Interrupt	Set	Behavior
Speech/Melody	4	11-bit resolution with pre-load counter
Timer	1	4 bits pre-load counter
External Interrupt	1	Occurs when P1.3 pad has a rising edge change (not supported for eSA010)

### 6.3 I/O Ports Description

The eSA Series supports a total of five ports. Each port contains 4 bits. See Part List (Section 3) to check which body possesses which port.

**Port 1:** Input application only with pull low resistor and wake-up mechanism. The pull low resistor can be enabled or disabled, and the wake-up mechanism is always available (enabled) (not supported for eSA010).

**Port 2:** Available as input or output as defined by the Control Register. When set to input status, the pull low resistor can be enabled or disabled. When set to output status, another register is used to select port to sink or drive outside circuit. The port is also equipped with the wake-up mechanism which can be enabled or disabled under either input or output mode.

**Port 3:** Port 3 characteristics are the same as Port 2 except for the wake-up mechanism which can be enabled or disabled under input mode only (not supported for eSA010).



**Port 4:** Applicable in input or output mode which is controllable through Control Register. Both wake-up and pull low registers are not available under input mode. Thus, under input status, external signal cannot be set to floating status (not supported for eSA010)

**Port 5:** For output application only (not supported for eSA010)

Each of the port properties may be summarized as follows:

Port	Available	I/O Direction Controllable	Input Mechanism	
			Pull Low	Wake-up
Port 1	I	×	√ (c)	√
Port 2	I/O	√ (c)	√ (c)	√ (c)
Port 3	I/O	√ (c)	√ (c)	√ (c)
Port 4	I/O	√ (c)	×	×
Port 5	O	×	×	×

**Legend:** **I:** input; **I/O:** input/output; **O:** output.  
**x:** Not available  
**√:** Available  
**(c):** Can be enabled/disabled by register

### 6.3.1 Pull Low Structure of Ports 1, 2, and 3

The pull low resistor is only valid when ports are in input mode. Under input mode, a control register is used to enable or disable the pull low resistors.

A strong pull low resistor (100K ohm order) protects pads from noise influence and is turned off to save power when pads status is “1” (High). The weak pull low resistor (1M ohm order) keeps the pads’ default value at “0” (Low).

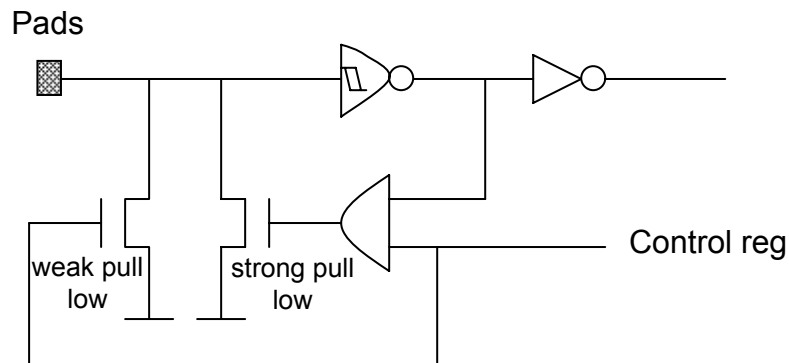

Fig. 6-1 Pull Low Structure of Ports 1, 2, and 3

## 7 Electrical Characteristics

### 7.1 Absolute Maximum Ratings

Parameter	Specification
Supply voltage ( $V_{DDx} - V_{SSx}$ )	-0.3V to +6.0V
Input voltage	$V_{SSx} - 0.3V$ to $V_{DDx} + 0.3V$
Operating Temperature	0°C to 70°C
Storage Temperature	-55°C to 125°C

### 7.2 DC Characteristics

$V_{DDx}=3V$ ,  $V_{SSx}=0V$ ,  $T_a=25^\circ C$  unless otherwise specified

Items	Sym.	Min	Typ.	Max.	Unit	Condition
Operating Voltage	$V_{DDx}$	2.2	3.0	5.1	V	-
Standby current	$I_{DDS}$	-	-	1.0	$\mu A$	Sleep mode, no load
Operating mode current	$I_{green}$	-	10	15	$\mu A$	Green mode, no load ( $F = F_{lo} = 32kHz$ )
	$I_{op}$	-	1.5	3	mA	no load, D/A stop, ( $F = F_{High} = 3.58MHz$ )
Drive current of P2, P3, P4, P5, IRout	$I_{OD}$	2.0	3.0	-	mA	$V_{OD}=2.4V$
Sink current of P2, P3, P4, P5, IRout	$I_{OS}$	2.3	3.5	-	mA	$V_{OS}=0.4V$
Input current of P1, P2, P3, P4, IRin	$I_{IH}$	-	3.0	5	$\mu A$	-
Input positive going threshold voltage	$V_{IH}$	2	-	-	V	$V_{DD}=3.0V$
Input negative going threshold voltage	$V_{IL}$	-	-	0.7	V	$V_{DD}=3.0V$
Output current of VO1A	$I_{VO1A}$	-	3	-	mA	$V_{VO1A}=0.7V$ (traditional current DA)
Output current of VO1A, VO1B	$I_{VO1A/B}$	-	200	-	mA	$V_{VO1A/B}=1/2 V_{DD}$ (PWM DA)
Reset warm up time	$T_r$	-	64	-	ms	-
Wake up time	$T_w$	-	1	-	ms	-
Oscillation resistor	$R_{osch}$	-	56.0	-	K $\Omega$	$F_{High}=3.58MHz$
	$R_{osch}$	-	51.0	-	K $\Omega$	$F_{High}=4MHz$
	$R_{osclo}$	-	1	-	M $\Omega$	$F_{lo}=32kHz$
Oscillation freq.	$F_{High}$	3.22	3.58	3.94	MHz	Normal mode
	$F_{High}$	3.6	4	4.4	MHz	$V_{DD}=2.2 \sim 5.1V$
	$F_{lo}$	26	32	38	kHz	Green mode $V_{DD}=2.2 \sim 5.1V$

## 8 Oscillator Frequency Deviation

### 8.1 Oscillator Frequency vs. R<sub>osc</sub> (VDD=3V)

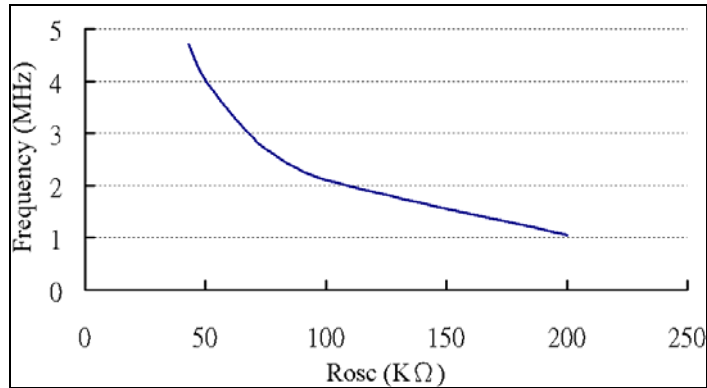

### 8.2 Oscillator Frequency vs. VDD (Normal Mode, R<sub>osc</sub>=56KΩ)

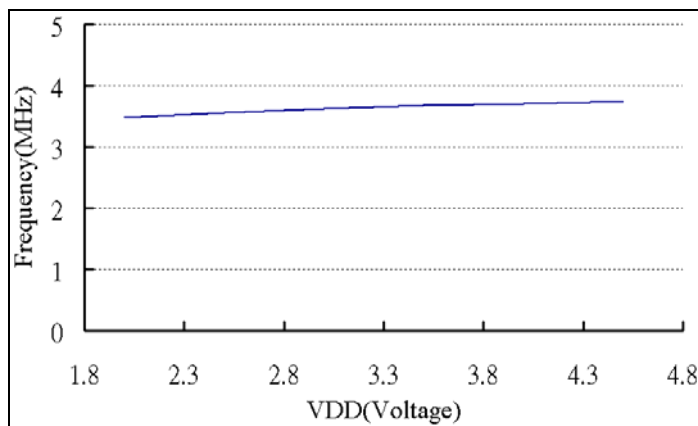

### 8.3 Oscillator Frequency vs. VDD (Normal Mode, $R_{osc}=51K\Omega$ )

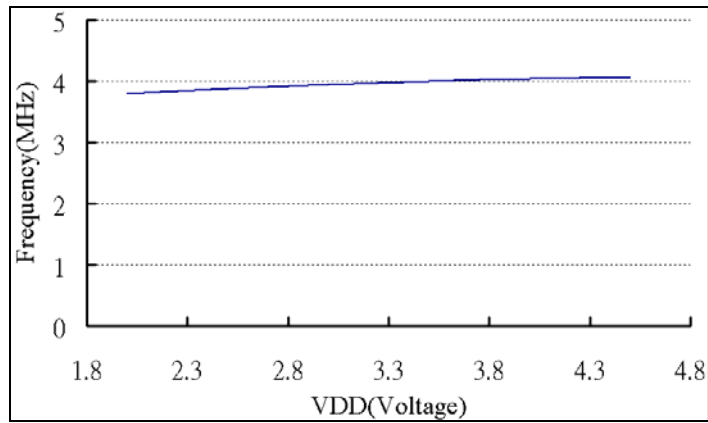

### 8.4 Oscillator Frequency vs. VDD (Green Mode, $R_{osc}=1M\Omega$ )

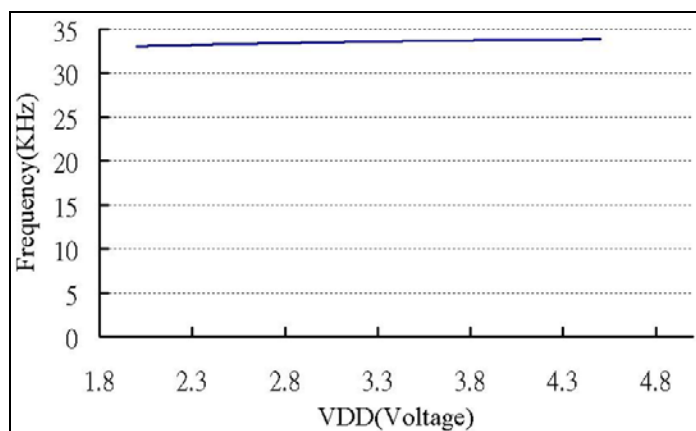

## 9 Application Circuit

Important notes for the following application circuits:

1. Adding a 0.1 $\mu$ F ceramic capacitor between Ground and IC's Vdd0 pad is necessary to suppress noise.
2. For noisy power supply application, suppress noise by adding a 0.1 $\mu$ F ceramic capacitor between Ground and power VCC & IC's Vdd1 pad.
3. For heavy loading application, it is recommended that an electrolytic capacitor is added between Vdd1 and ground. The recommended capacitor value for button cell applications is 10 $\mu$ F~220 $\mu$ F.

### 9.1 R Oscillator in Normal Mode (Without Green Mode)

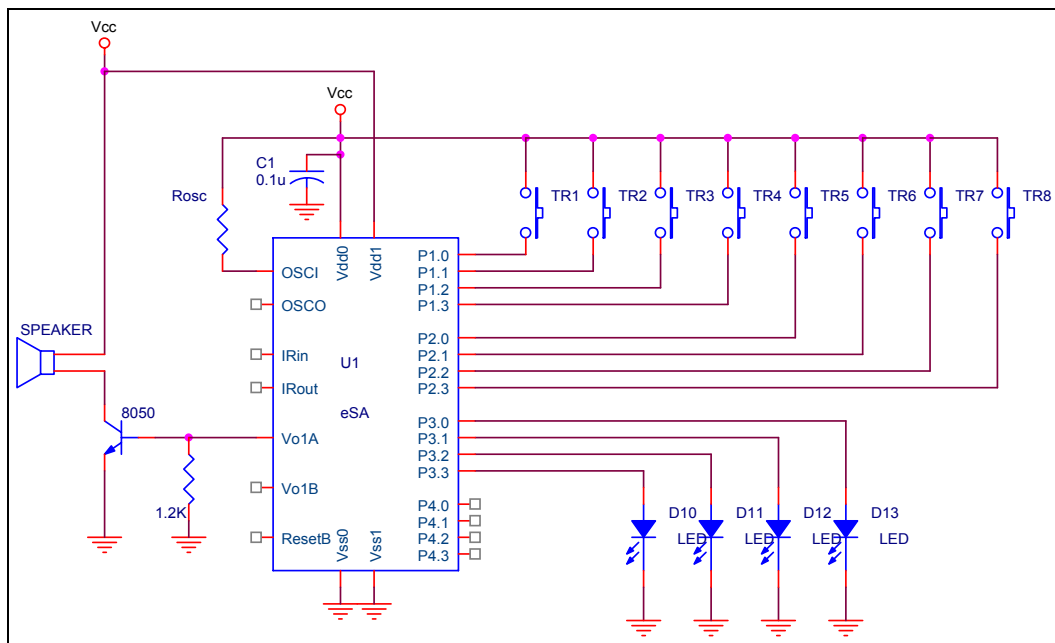

## 9.2 Crystal Oscillator in Normal Mode (Without Green Mode)

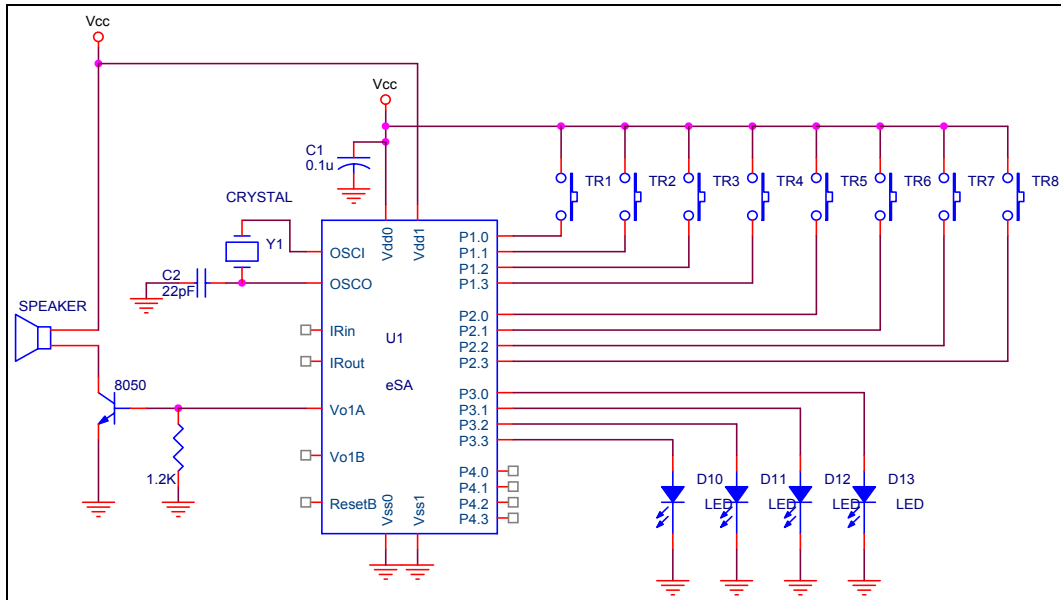

## 9.3 R oscillator in Normal mode & Green mode

The circuit with Green mode can add a 1MΩ resistor connected to OSCO pin

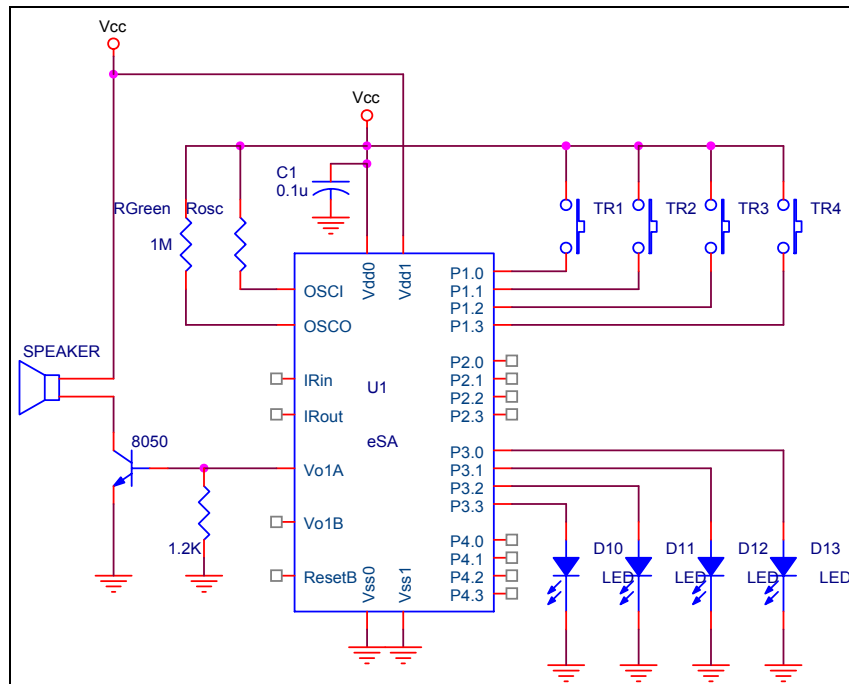

## 9.4 Crystal Oscillator in Normal Mode and R Oscillator in Green Mode

A 1MΩ resistor must be connected to OSCO pin under circuit with Green mode

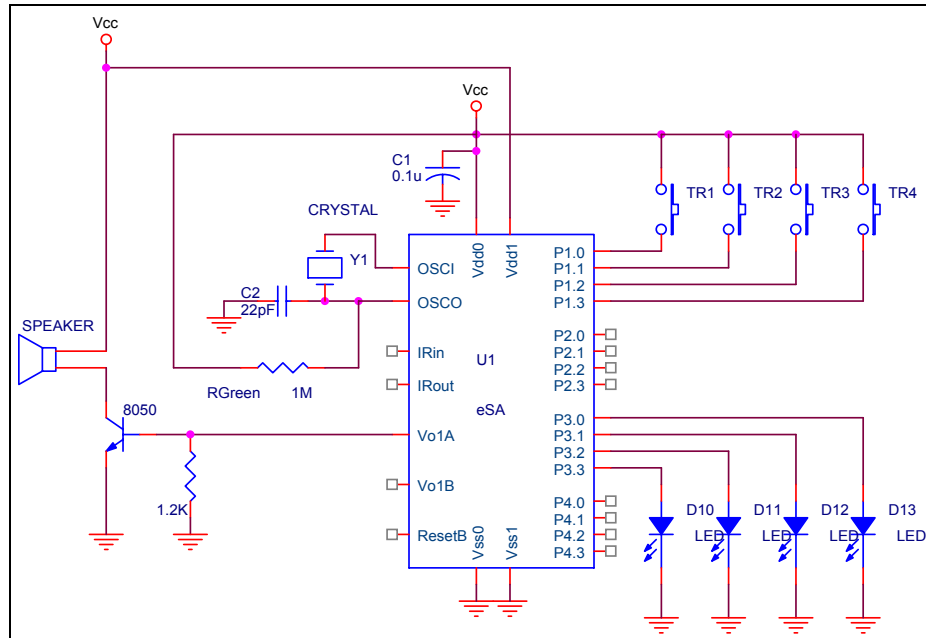

**eSA Series**  
General Purpose Tiny Controller with  
Four-Channel Speech and Melody Synthesis

---

