eSM Series

Tiny Controller-Based Speech Synthesizer

Product Specification

DOC. VERSION 1.1

ELAN MICROELECTRONICS CORP.

January 2010



Trademark Acknowledgments:

IBM is a registered trademark and PS/2 is a trademark of IBM.

Windows is a trademark of Microsoft Corporation.

ELAN and ELAN logo  are trademarks of ELAN Microelectronics Corporation.

Copyright © 2004~2005 by **ELAN Microelectronics Corporation**

All Rights Reserved

Printed in Taiwan

The contents of this specification are subject to change without further notice. ELAN Microelectronics assumes no responsibility concerning the accuracy, adequacy, or completeness of this specification. ELAN Microelectronics makes no commitment to update, or to keep current the information and material contained in this specification. Such information and material may change to conform to each confirmed order.

In no event shall ELAN Microelectronics be made responsible for any claims attributed to errors, omissions, or other inaccuracies in the information or material contained in this specification. ELAN Microelectronics shall not be liable for direct, indirect, special incidental, or consequential damages arising from the use of such information or material.

The software (if any) described in this specification is furnished under a license or nondisclosure agreement, and may be used or copied only in accordance with the terms of such agreement.

ELAN Microelectronics products are not intended for use in life support appliances, devices, or systems. Use of ELAN Microelectronics product in such applications is not supported and is prohibited.

NO PART OF THIS SPECIFICATION MAY BE REPRODUCED OR TRANSMITTED IN ANY FORM OR BY ANY MEANS WITHOUT THE EXPRESSED WRITTEN PERMISSION OF ELAN MICROELECTRONICS.



ELAN MICROELECTRONICS CORPORATION

Headquarters:

No. 12, Innovation Road 1
Hsinchu Science Park
Hsinchu, Taiwan 30077
Tel: +886 3 563-9977
Fax: +886 3 563-9966
<http://www.emc.com.tw>

Hong Kong:

**Elan (HK) Microelectronics
Corporation, Ltd.**
Flat A, 19F., World Tech Centre 95
How Ming Street, Kwun Tong
Kowloon, HONG KONG
Tel: +852 2723-3376
Fax: +852 2723-7780
elanhk@emc.com.hk

USA:

**Elan Information
Technology Group (USA)**
1821 Saratoga Ave., Suite 250
Saratoga, CA 95070
USA
Tel: +1 408 366-8225
Fax: +1 408 366-8220

Shenzhen:

**Elan Microelectronics
Shenzhen, Ltd.**
3F, SSMEC Bldg., Gaoxin S. Ave. I
Shenzhen Hi-tech Industrial Park
(South Area), Shenzhen
CHINA 518057
Tel: +86 755 2601-0565
Fax: +86 755 2601-0500

Shanghai:

**Elan Microelectronics
Shanghai, Ltd.**
#23, Zone 115, Lane 572, Bibo Rd.
Zhangjiang Hi-Tech Park
Shanghai, CHINA 201203
Tel: +86 21 5080-3866
Fax: +86 21 5080-4600

Contents

1	General Description	1
2	Features	1
3	eSMP020 Pin Assignments.....	2
4	Absolute Maximum Ratings	3
5	Electrical Characteristics	3
6	Application Circuit	4
6.1	eSM003 Application Circuit for 4-Key	4
6.2	eSM003 Application Circuit for 8-Key	5
6.3	eSM005 ~ eSM020 Application Circuit for 4-Key	5
6.4	eSM005 ~ eSM020 Application Circuit for 16-Key	6
6.5	eSM005 ~ eSM020 Application Circuit for 32-Key	6
6.6	eSM005 ~ eSM020 Application Circuit for 64-Key	7
6.7	eSM005 ~ eSM020 Application Circuit for 128-Key	8

Specification Revision History

Doc. Version	Revision Description	Date
1.0	Initial version	2004/10/04
1.1	Add the P1,P2,P3 Input High/Low Voltage for Electrical Characteristics.	2010/01/07



1 General Description

eSM Series are single chip Voice/Dual tone Melody/Dual tone Sound Effect synthesizer ICs. It contains one 4-bit input port (provided for eSM005 and above), two 4-bit I/O ports, a tiny controller, and adapts improved algorithm to achieve pure speech. User's applications, such as section combination, trigger modes, control outputs, keyboard matrix, and other logic functions, are easily implemented by programming through its tiny controller

2 Features

Product	eSM003	eSM005	eSM010	eSM015	eSM020	eSMP020 (OTP)*
Duration (@ 6K sample rate)	3 sec	5 sec	10 sec	15 sec	21 sec	21 sec
ROM (bits)	10Kx10	16Kx10	32Kx10	48Kx10	64Kx10	64Kx10
PROGRAM ROM (bits)	8Kx10					
RAM (bits)	16x4	32x4				
I/O pins	8 I/O	4 I, 8 I/O				
	P2.0 ~ P2.3 P3.0 ~ P3.3	P1.0~P1.3, P2.0~P2.3, P3.0~P3.3				
IR	Yes					
Flash with Volume (pin)	Yes (P3.3)					

*eSMP020 is a flexible OTP IC which can be programmed to clone any of its smaller sister IC's, i.e., eSM003 ~ eSM020.

*If to verify the kit board by using the kernel chip. In order to ensure the characteristic, please double confirm it by using eSMP020.

- ◆ Single power supply 2.4 V ~ 5 V
- ◆ One 6-bit timer overflow control
- ◆ PCM, ASPCM, and ASPCM+ synthesizer, and dual tone melody/sound effect generator
- ◆ 4K~32K Hz playing speed for voice play-back
- ◆ Multiple tempos for dual tone melody/sound effect play-back
- ◆ Variable beats for dual tone melody/sound effect play-back
- ◆ Multiple volume control levels
- ◆ Fixed current D/A output to drive external connected transistor for voice output
- ◆ Pin P3.2 can be programmed as IR communication pin to generate 38KHZ carrier
- ◆ The IR function of eSM003 is only available in assembly language.

3 eSMP020 Pin Assignments

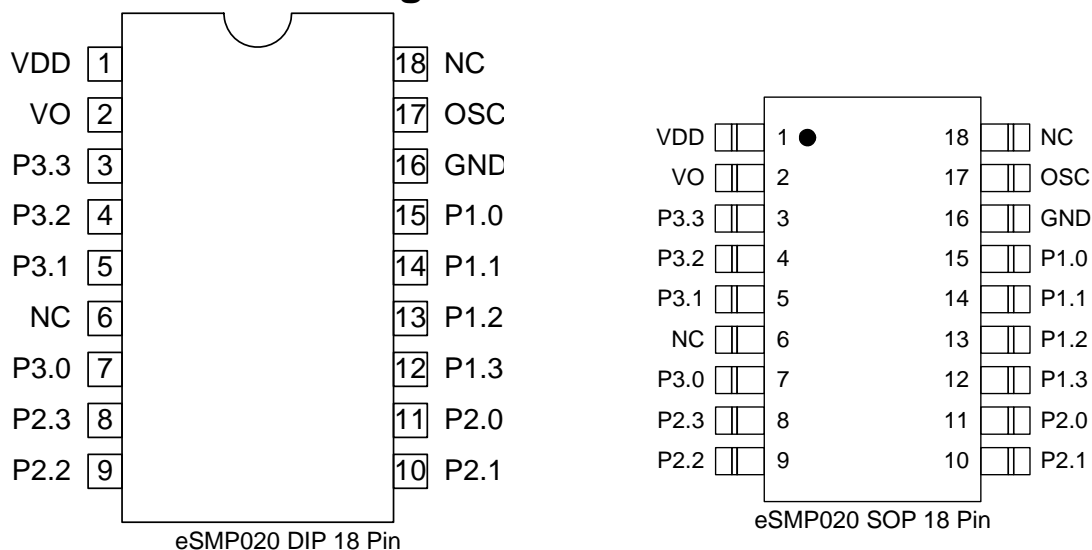

Symbol	I/O	Function
P1.0	I	Bit 0 of Port 1 (not applicable for eSM003)
P1.1	I	Bit 1 of Port 1 (not applicable for eSM003)
P1.2	I	Bit 2 of Port 1 (not applicable for eSM003)
P1.3	I	Bit 3 of Port 1 (not applicable for eSM003)
P2.0	I/O	Bit 0 of Port 2
P2.1	I/O	Bit 1 of Port 2
P2.2	I/O	Bit 2 of Port 2
P2.3	I/O	Bit 3 of Port 2
P3.0	I/O	Bit 0 of Port 3
P3.1	I/O	Bit 1 of Port 3
P3.2	I/O	Bit 2 of Port 3 (IR Tx)
P3.3	I/O	Bit 3 of Port 3 (Flash with volume output)
VDD	I	Positive power supply.
OSC	I	Ring oscillator input pin.
VSS	I	Negative power supply
VO	O	Voice Output



4 Absolute Maximum Ratings

Items	Symbol	Min	Max	Unit
Supply Voltage	$V_{DD}-V_{SS}$	-0.3	+6.0	V
Input Voltage	V_{IN}	$V_{SS}-0.3$	$V_{DD}+0.3$	V
Operating Temperature	T_{OP}	-20.0	+70.0	°C
Storage Temperature	T_{STG}	-55.0	+125.0	°C

5 Electrical Characteristics

(25°C, Vdd=3.0 Volts unless otherwise specified)

Items	Sym	Min.	Typ.	Max.	Unit	Condition
Operating Voltage	V_{DD}	2.4	3.0	5.1	V	–
Standby Current	I_{DDS}	–	–	1.0	uA	$V_{DD}=3V$
Operating Current	I_{DDO}	–	–	280	uA	$V_{DD}=3V$, no load
P2, P3 Drive Current	I_{OD}	1.0	–	–	mA	$V_{DD}=3V$, $V_O=2.4V$
P2, P3 Sink Current	I_{OS}	1.6	–	–	mA	$V_{DD}=3V$, $V_O=0.4V$
P1,P2,P3 Input High Voltage	V_{IH}	$0.6V_{DD}$	--	$V_{DD}+0.3$		Schmitt Trigger
P1,P2,P3 Input Low Voltage	V_{IL}	-0.3	--	$0.25V_{DD}$		Schmitt Trigger
P1 Input Current	I_{IH}	–	3.0	10.0	uA	$V_{DD}=3V$ (not applicable to eSM003)
VO Output Current	I_{VO}	2.0	3.0	4.0	mA	$V_{DD}=3V$, $V_O=0.7V$ (Step 7)
Oscillation Resistor	R	–	470	–	K Ω	$V_{DD}=3V$
Oscillation Frequency	F_{OSC}	–	1.0	–	MHz	$V_{DD}=3V$

6 Application Circuit

Important notes for the following application circuits:

1. For noisy power supply application, suppress noise by adding a 0.1 μ F ceramic capacitor between ground and power pad.
2. The recommended value of the bypass resistor for button cell application is 750 Ω or less.
3. For heavy loading application, it is recommended that an electrolytic capacitor is added between VDD and ground. The recommended capacitor value for button cell applications is 10 μ F.
4. The use of spring direct trigger is not recommended. If you must use such trigger, you need to add a ceramic capacitor between trigger pin and ground to debounce the spring noise. The recommended capacitor value is 0.001 ~ 0.01 μ F.

6.1 eSM003 Application Circuit for 4-Key

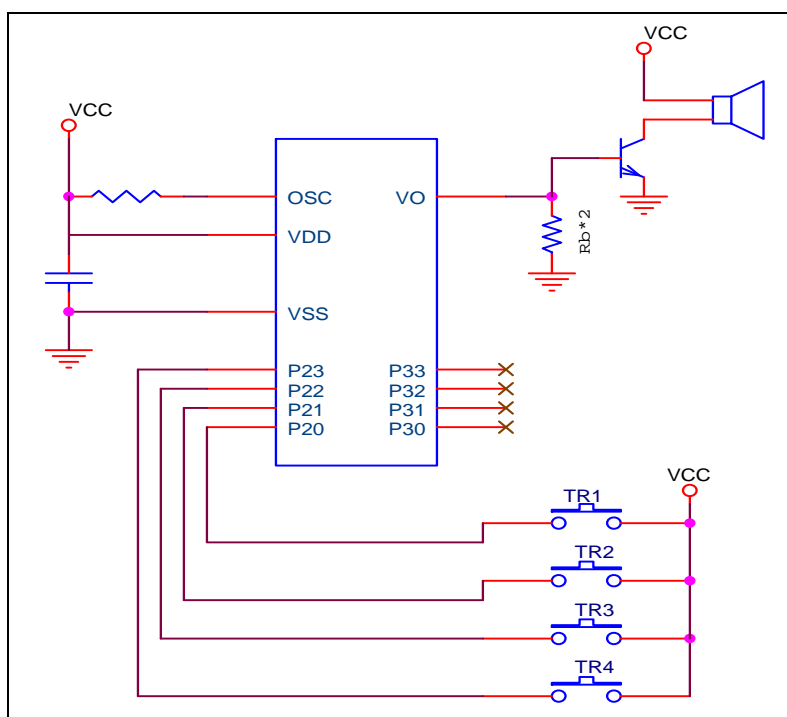

6.2 eSM003 Application Circuit for 8-Key

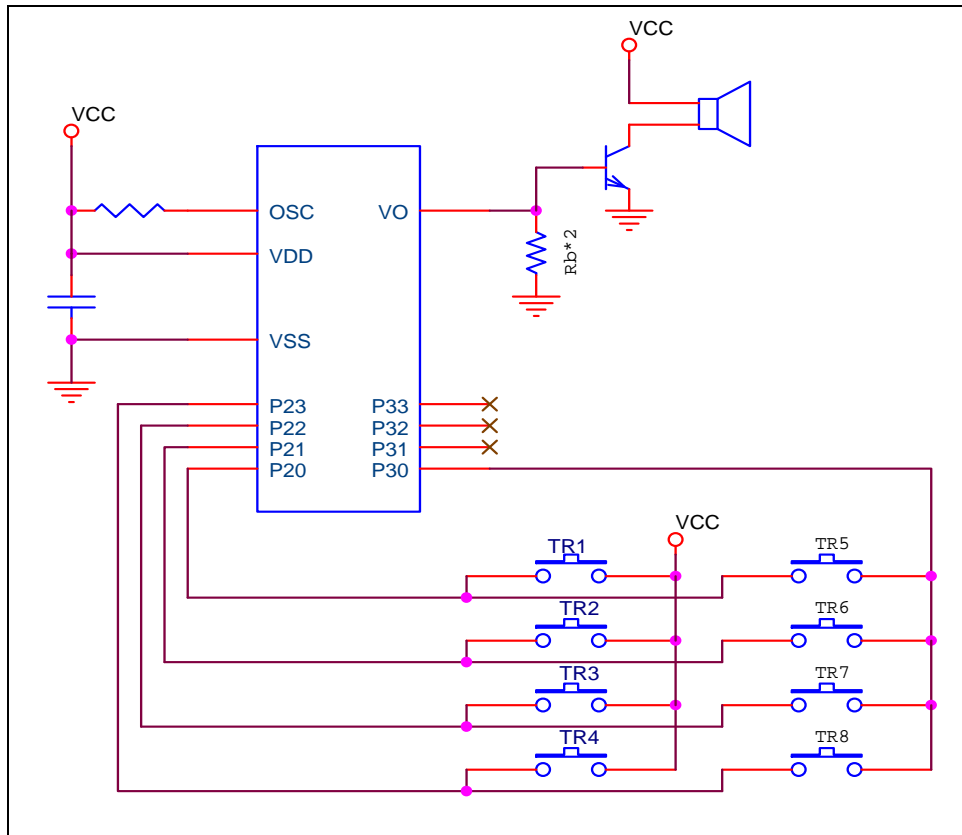

6.3 eSM005 ~ eSM020 Application Circuit for 4-Key

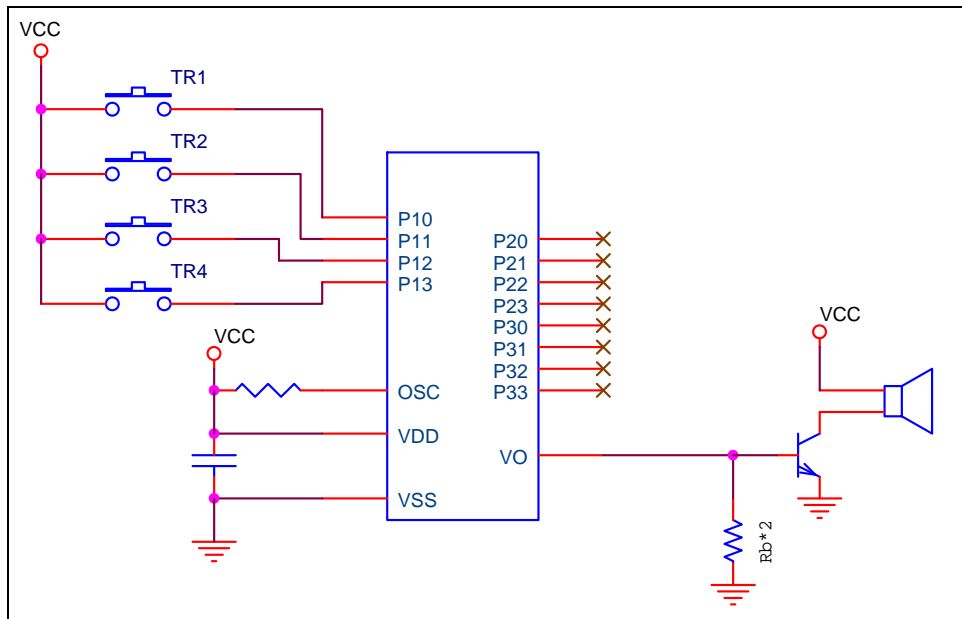

6.4 eSM005 ~ eSM020 Application Circuit for 16-Key

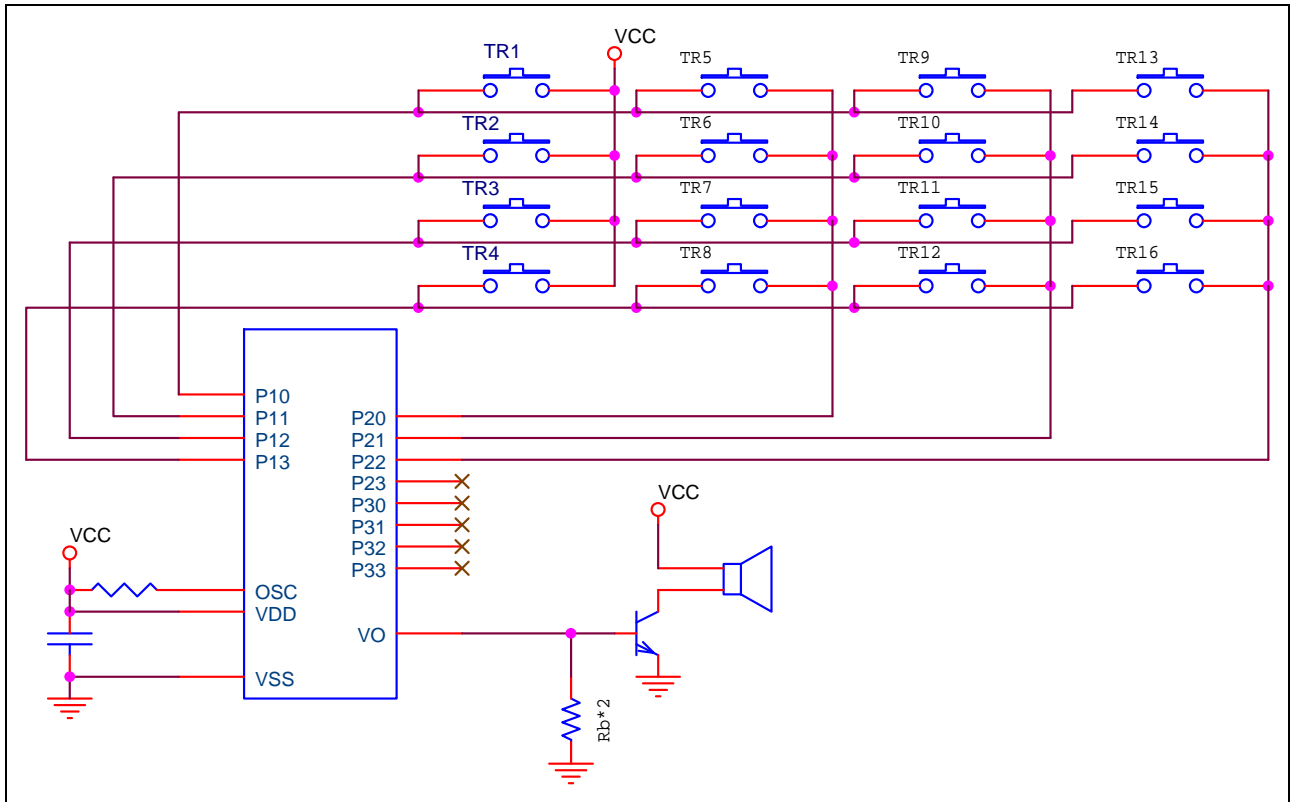

6.5 eSM005 ~ eSM020 Application Circuit for 32-Key

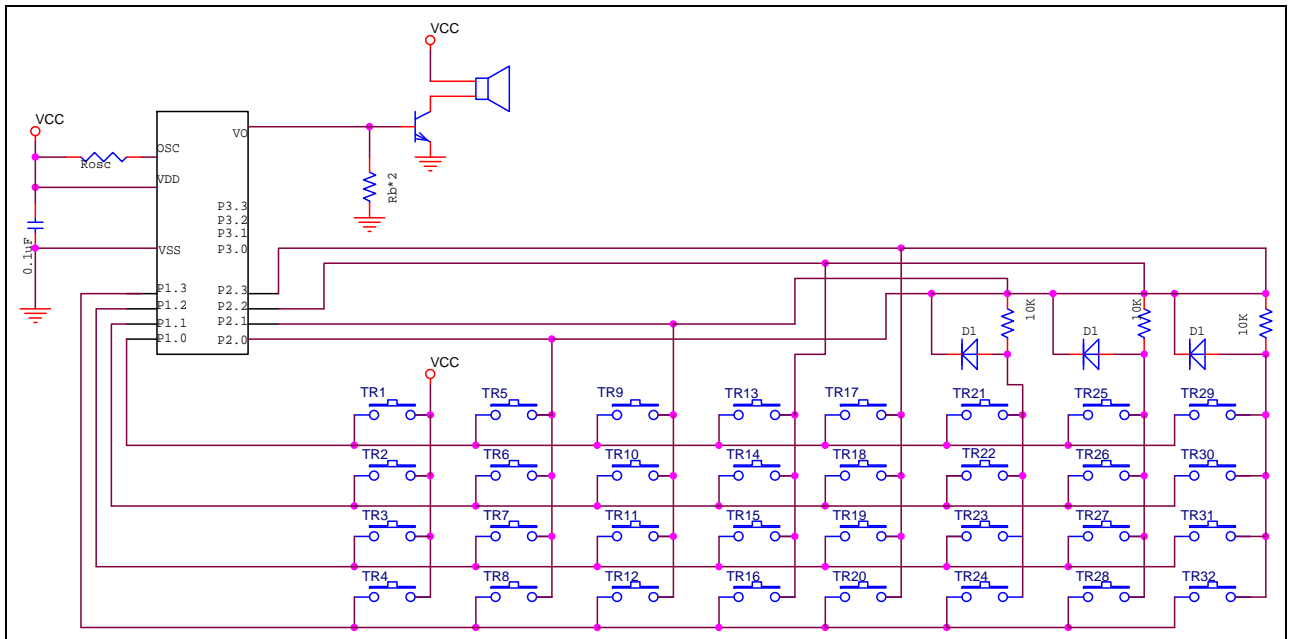

6.6 eSM005 ~ eSM020 Application Circuit for 64-Key

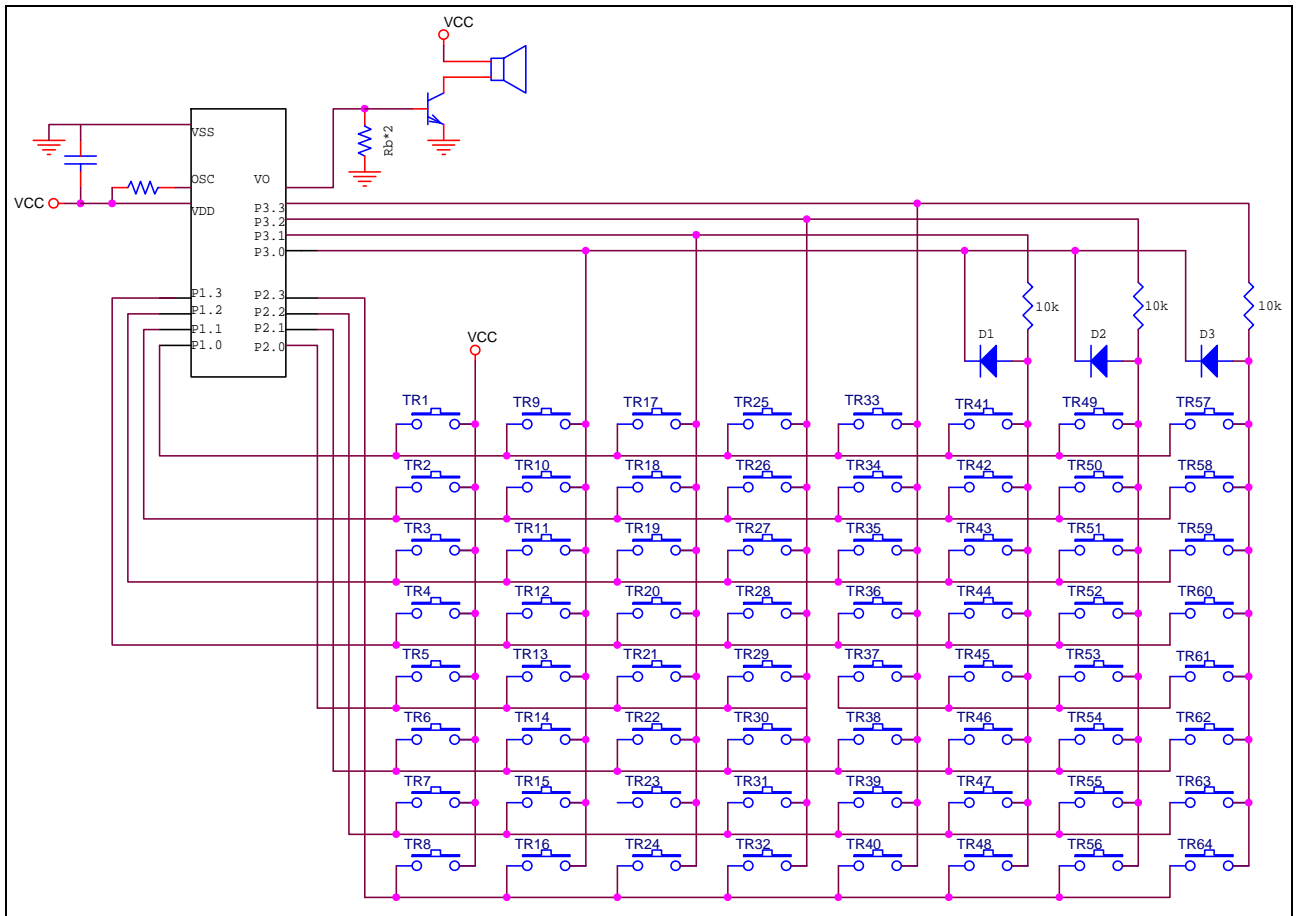

6.7 eSM005 ~ eSM020 Application Circuit for 128-Key

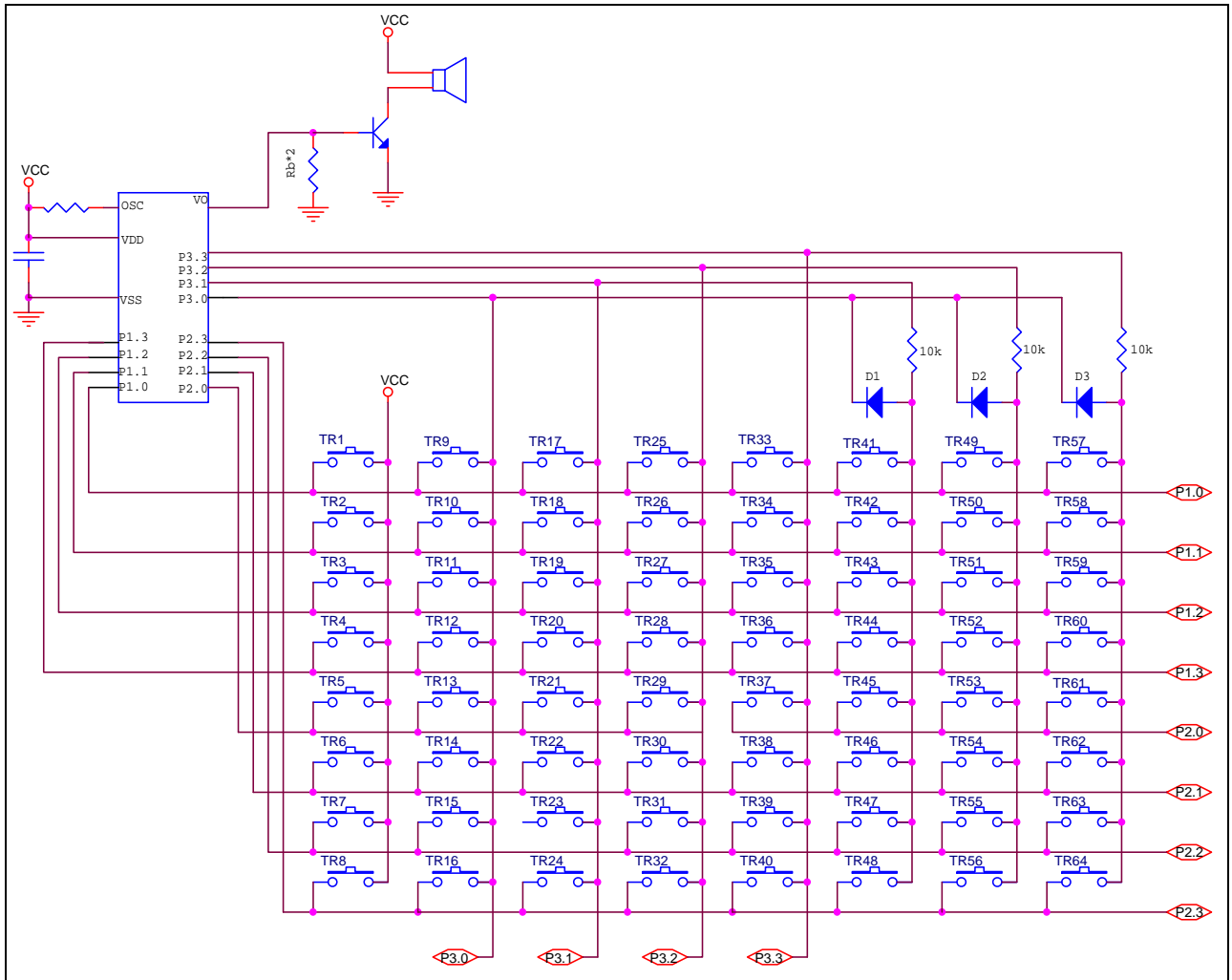

(Continued next page)

