

Description

The iT3015 is a packaged differential amplifier designed for use as an optical modulator predriver with limiting functionality in 10.7 Gb/s and 12.5 Gb/s (OC-192) optical transmitters and receivers. It allows single-ended input signals of 350 mVpp to 900 mVpp or differential signals of 250 mVpp to 1800 mVpp to be limited at a constant differential output voltage of 6.0 Vpp. It provides output voltage control and allows external offset correction. iT3015 also provides excellent linear performance when operating at lower output voltages. Both AC and DC input coupling are allowed. DC-coupled SCFL differential input (input "high" voltage = 0 V, input "low" voltage = -900 mV) is allowed.

Features

- ❖ Limiting function with 6 Vpp differential output
- ❖ 3 dB bandwidth: 10 GHz
- ❖ Differential gain: 27 dB
- ❖ Standard bias supply levels: -5.2 V, +4 V
- ❖ Power consumption: 1.43 W
- ❖ Low group delay and jitter
- ❖ Output voltage control
- ❖ AC and DC input coupling (SCFL compatible)
- ❖ AC and DC output coupling
- ❖ Low-cost JEDEC QFP-N (MO-220) package

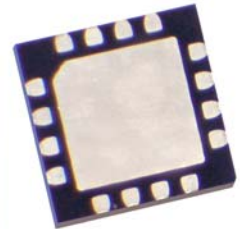

Absolute Maximum Ratings

Symbol	Parameters/conditions	Min.	Max.	Units
V _{ee}	Power supply voltage	-8	0	V
V _{cc}	Power supply voltage	0	8	V
V _d	Applied voltage at data input (differential)		3	V
V _m	Applied voltage at data input (single ended)		1.5	V
I _{DC IN (+),(-)}	Offset control current		5	mA
T _{ch}	Maximum channel temperature		150	°C
T _{stg}	Storage temperature	-65	150	°C

Recommended Operating Conditions

At ambient temperature

Symbol	Parameters/conditions	Min.	Typ.	Max.	Units
T _c	Operating temperature range (T _{case})	0		65	°C
V _{ee}	Negative power supply voltage	-5.45	-5	-4.75	V
V _{cc}	Positive power supply voltage	3.8	4	4.2	V
I _{ee}	Negative supply current	162	190	219	mA
I _{cc}	Positive supply current	102	120	138	mA
V _{DC IN}	Offset control voltage	-5		5	V
V _{ctrl}	Voltage control pin	-2.7		0	V
V _m	Applied peak-peak voltage at data input (single ended)	350		900	mV
V _d	Applied peak-peak voltage at data input (differential)	250		1800	mV
V _{indc}	DC input voltage (with DC-coupled input)	-0.5		0	V
R	Data bit rate			10.7	Gb/s



iT3015 10 GHz High-Voltage Differential Amplifier

Electrical Characteristics

At ambient temperature
V_{ee}=-5 V, V_{cc}=+4 V

Symbol	Parameters/conditions	Min.	Typ.	Max.	Units
P	Power consumption	1218	1430	1647	mW
Z _{DCin}	Input impedance at DCin, /DCin	900	1000	1100	Ohm
G	Differential small signal gain	26	27		dB
B _{3dB}	3 dB bandwidth	9	10		GHz
RL _{in}	Input return loss (up to 10 GHz)	12	20		dB
RL _{out}	Output return loss (up to 10 GHz)	5	12		dB
V _{out}	Output peak-peak voltage (differential) (V _{ctrl} = -2.7V for max. output voltage)	5.5	6		V
ΔV _{out}	V _{out} sensitivity vs bias (V _{ee} =-5 V +/-5%, V _{cc} =4 V +/-5%)			+/-11	%
V _{outdc}	DC output voltage (DC coupled to 50 ohm load)	550	650	750	mV
Tr _{se}	Output rise time (single ended)		29	32	ps
Tf _{se}	Output fall time (single ended)		25	30	ps
J _{RMS}	RMS jitter degradation (*)		1	1.5	ps

$$(*) J_{RMS} = \sqrt{(J_{RMS_out})^2 - (J_{MRS_thru})^2}$$

S-Parameter Data

Measured on connectorized evaluation board

V_{ee}=-5 V, V_{cc}=+4 V

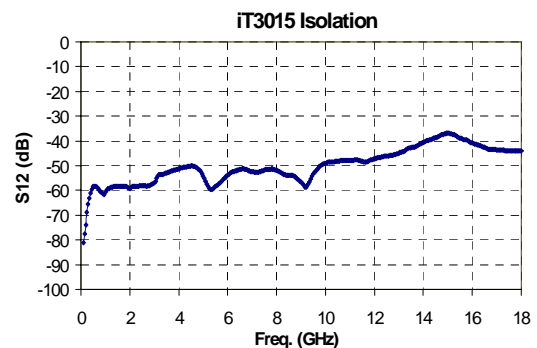
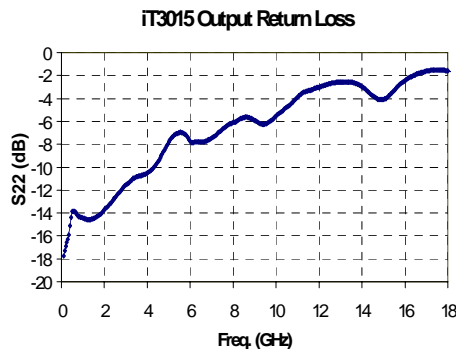
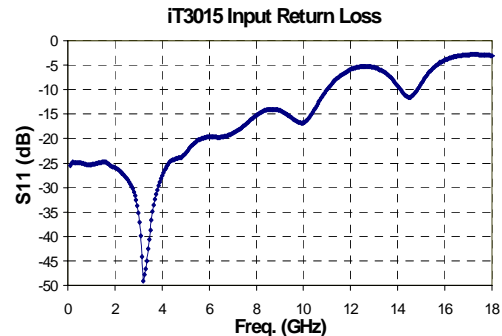
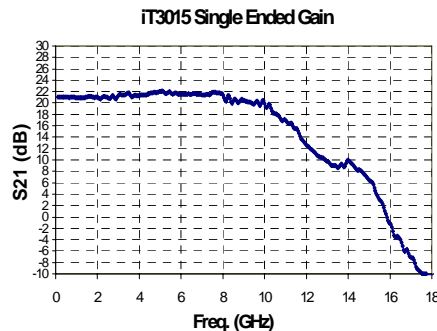

Eye Diagram Performance

Vee=-5 V, Vcc=+ V

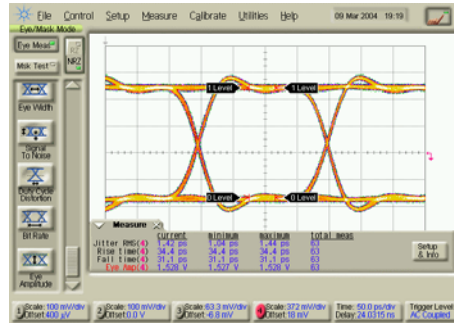

Linear performance
Bit rate: 5.0 Gb/s
Vin=±75 mVpp, Vout=±1.5 mVpp

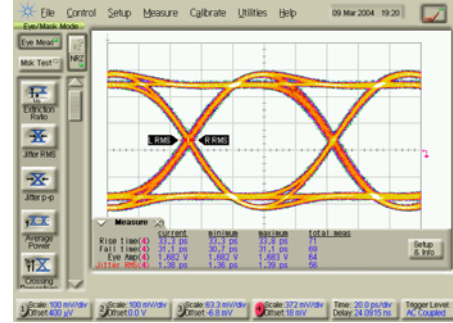

Linear performance
Bit rate: 10.7 Gb/s
Vin=±75 mVpp, Vout=±1.4 mVpp

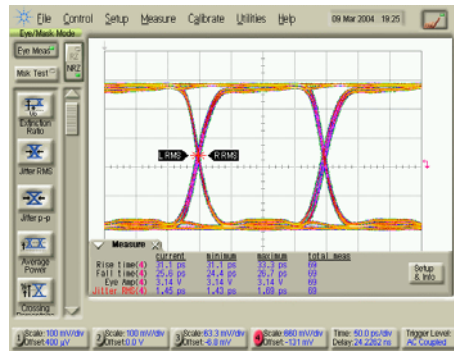

Saturated performance
Bit rate: 5.0 Gb/s
Vin=±400 mVpp, Vout=±3.1 Vpp

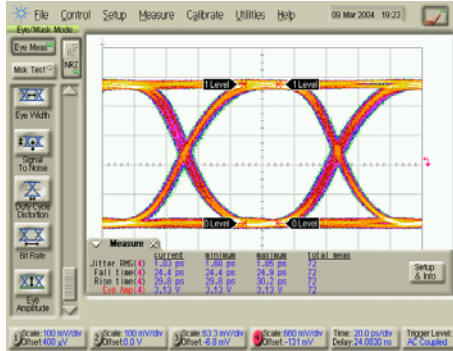

Saturated performance
Bit rate: 10.7 Gb/s
Vin=±400 mVpp, Vout=±3.1 Vpp

Device Diagram

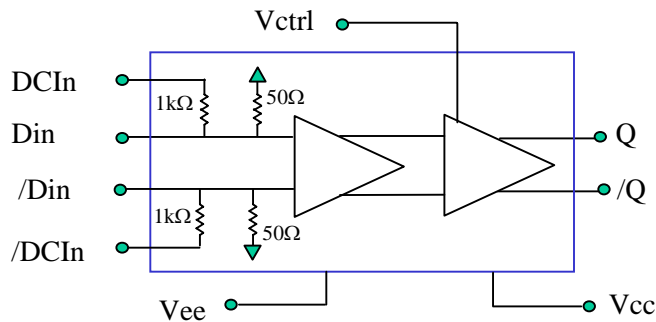

Recommended Operational Setup

DC blocking capacitors optional

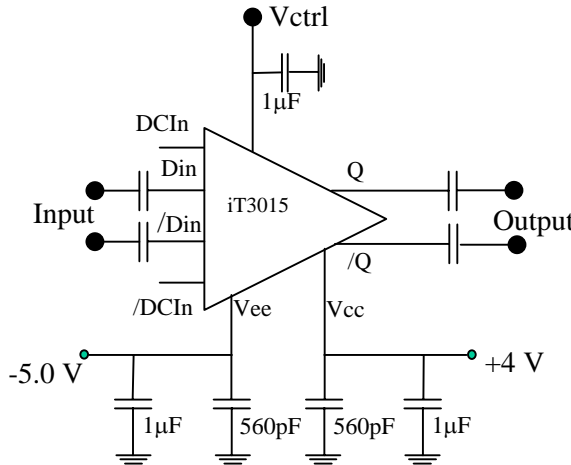

Bias Conditions

- Apply +4.0 V at Vcc
- Apply -5.2 V at Vee
- Vctrl = -2.7 V or open for maximum output voltage
- Vctrl from -2.7 V to -1 V for output voltage control

Dimensions, Pinouts

Pinouts

- P1: GND
- P2: Din (RF input)
- P3: /Din (/RF input)
- P4: GND
- P5: /DC in
- P6: Vee
- P7: N/C
- P8: N/C
- P9: GND
- P10: /Q (/RF out)
- P11: Q (RF out)
- P12: GND
- P13: NC
- P14: Vctrl (voltage control)
- P15: Vcc
- P16: DCin

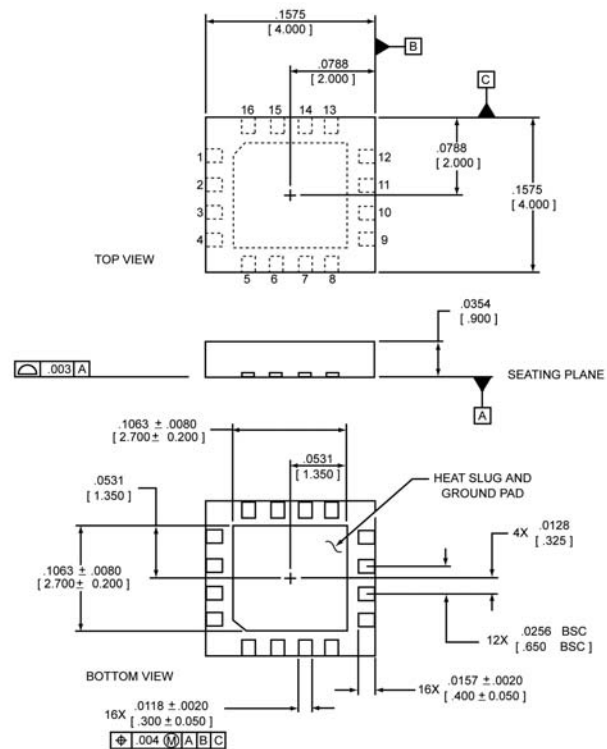

Unless otherwise specified, dimensions are in inches (mm), and tolerance on dimensions is:

$$\pm 0.0039$$

$$[0.100]$$