

Off-Line Digital Green-Mode Quasi-Resonant PWM Controller

1 Description

The iW1760B is a high performance AC/DC power supply controller which uses digital control technology to build peak current mode PWM flyback power supplies. The device operates in quasi-resonant mode to provide high efficiency along with a number of key built-in protection features while minimizing the external component count, simplifying EMI design and lowering the total bill of material cost. The iW1760B removes the need for secondary feedback circuit while achieving excellent line and load regulation. It also eliminates the need for loop compensation components while maintaining stability over all operating conditions. Pulse-by-pulse waveform analysis allows for a loop response that is much faster than traditional solutions, resulting in improved dynamic load response. The built-in power limit function enables optimized transformer design in universal off-line applications and allows for a wide input voltage range.



Dialog's innovative proprietary technology ensures that power supplies built with the iW1760B can achieve both the highest average active efficiency and less than 50mW no-load power consumption in 20W output power range, and

2 Features

- No-load power consumption < 50mW at 230V_{AC} along with fast dynamic load response and short turn-on delay in typical 20W and above adapter applications
- Primary-side feedback eliminates opto-isolators and simplifies design
- Adaptively controlled soft-start enables fast and smooth start-up for a wide range of capacitive loads (from 330µF to 6,000µF) with output voltage of 12V and above
- Tight constant-voltage regulation across line and load range
- Intelligent low power management achieves ultra-low operating current (~250µA) at no-load
- Proprietary optimized 79kHz maximum PWM switching frequency with quasi-resonant operation achieves best size, efficiency and common mode noise
- User-configurable 5-level cable drop compensation
- **EZ-EMI**® design enhances manufacturability
- Adaptive multi-mode PWM/PFM control improves efficiency
- Built-in single-point fault protections against output short-circuit, output over-voltage and output over-current
- Dedicated pins for external over-temperature protection and over-voltage protection, with latch function available
- Tight constant current control enables output current limit and over-load protection
- **SmartDefender**™ smart hiccup technology helps address issues of soft shorts in cables and connectors by effectively reducing the average output power at fault conditions without latch
- On-chip internal over-temperature protection
- No audible noise over entire operating range

3 Applications

- Power adapters for network devices and monitors
- Universal input AC/DC adapters (15W - 40W)

Off-Line Digital Green-Mode
Quasi-Resonant PWM Controller

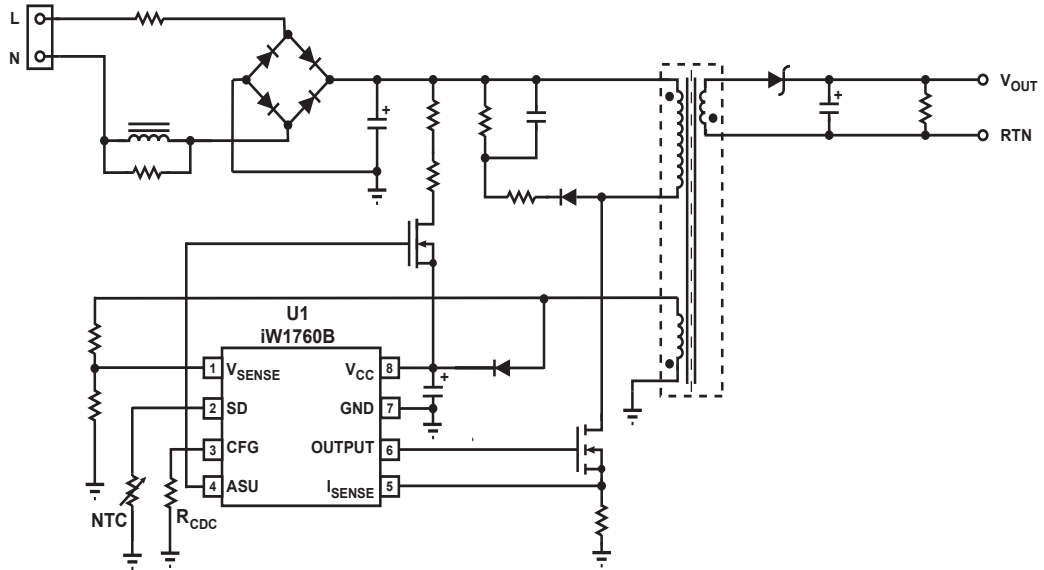

**Figure 3.1 : iW1760B Typical Application Circuit
(Using Depletion Mode N-FET as Active Start-up Device)
(Achieving < 50mW No-load Power Consumption in 20W Adapter Designs)**

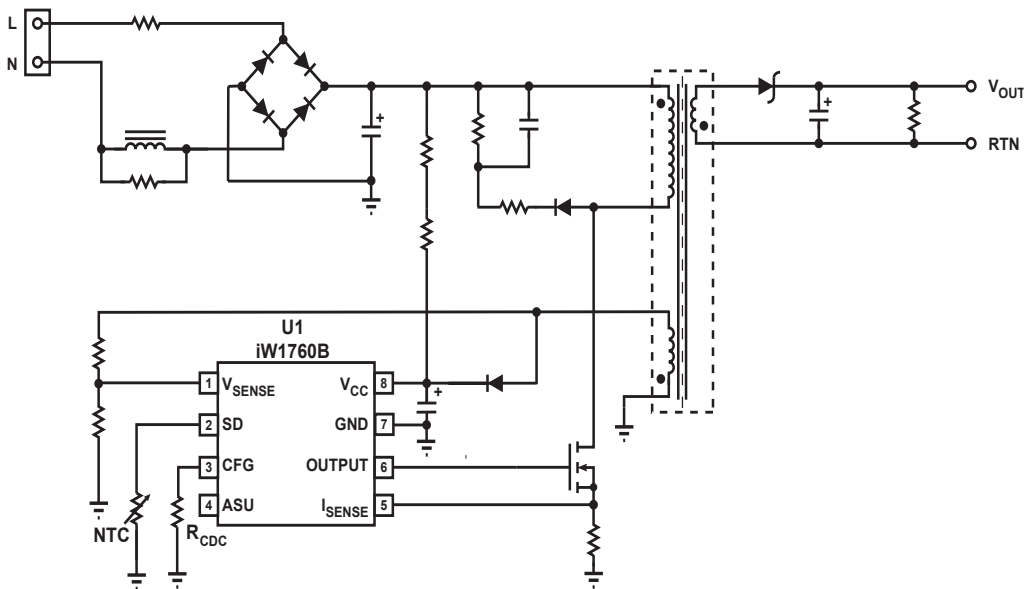

**Figure 3.2 : iW1760B Typical Application Circuit
(Alternative Circuit without Using Active Start-up Device)**

Note: Pin 4 (ASU) can be left unconnected if an active start-up device is not needed in the application circuit.

Off-Line Digital Green-Mode Quasi-Resonant PWM Controller

4 Pinout Description

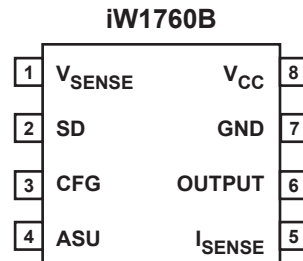

Figure 4.1 : 8 Lead SOIC-8 Package

Pin Number	Pin Name	Type	Pin Description
1	V _{SENSE}	Analog Input	Auxiliary voltage sense. Used for primary side regulation.
2	SD	Analog Input	External shutdown control. Can be configured for external over-temperature protection (OTP) by connecting an NTC resistor from this pin to Ground.
3	CFG	Analog Input	Used for external cable drop compensation (CDC) configuration and supplemental over-voltage protection (OVP).
4	ASU	Output	Control signal. Used for active start-up device (BJT or depletion mode NFET).
5	I _{SENSE}	Analog Input	Primary current sense. Used for cycle-by-cycle peak current control and limit.
6	OUTPUT	Output	Gate drive for external MOSFET switch.
7	GND	Ground	Ground.
8	V _{CC}	Power Input	IC power supply.

Off-Line Digital Green-Mode
Quasi-Resonant PWM Controller

5 Physical Dimensions

8-Lead Small Outline (SOIC) Package

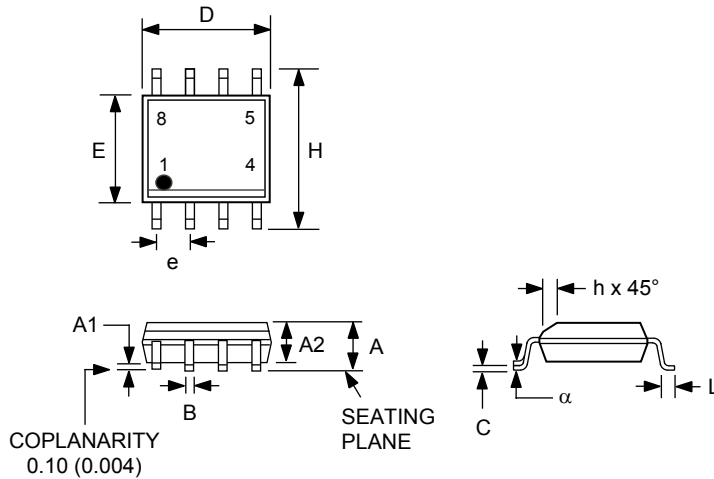

Symbol	Inches		Millimeters	
	MIN	MAX	MIN	MAX
A	0.053	0.069	1.35	1.75
A1	0.0040	0.010	0.10	0.25
A2	0.049	0.059	1.25	1.50
B	0.014	0.019	0.35	0.49
C	0.007	0.010	0.19	0.25
D	0.189	0.197	4.80	5.00
E	0.150	0.157	3.80	4.00
e	0.050 BSC		1.27 BSC	
H	0.228	0.244	5.80	6.20
h	0.10	0.020	0.25	0.50
L	0.016	0.049	0.4	1.25
α	0°	8°		

Compliant to JEDEC Standard MS12F

Controlling dimensions are in inches; millimeter dimensions are for reference only

This product is RoHS compliant and Halide free.

Soldering Temperature Resistance:

[a] Package is IPC/JEDEC Std 020D moisture sensitivity level 1

[b] Package exceeds JEDEC Std No. 22-A111 for solder immersion resistance; package can withstand 10 s immersion < 260°C

Dimension D does not include mold flash, protrusions or gate burrs. Mold flash, protrusions or gate burrs shall not exceed 0.15 mm per end. Dimension E1 does not include interlead flash or protrusion. Interlead flash or protrusion shall not exceed 0.25 mm per side.

The package top may be smaller than the package bottom. Dimensions D and E1 are determined at the outermost extremes of the plastic body exclusive of mold flash, tie bar burrs, gate burrs and interlead flash, but including any mismatch between the top and bottom of the plastic body.

6 Ordering Information

Part No.	Options	Package	Description
iW1760B-00	No OVP/OTP latch, 0.75V CC shutdown voltage, 100°C thermal shutdown recovery, no smart hiccup	SOIC-8	Tape & Reel ¹
iW1760B-01	OVP/ external OTP latch, 2.5V CC shutdown voltage, 100°C thermal shutdown recovery, no smart hiccup	SOIC-8	Tape & Reel ¹
iW1760B-10	No OVP/OTP latch, 0.75V CC shutdown, 120 °C thermal shutdown recovery, no smart hiccup	SOIC-8	Tape & Reel ¹
iW1760B-30	No OVP/OTP latch, 3V CC Shutdown, 100°C thermal shutdown recovery, no smart hiccup	SOIC-8	Tape & Reel ¹
iW1760B-31	No OVP/OTP latch, 3V CC shutdown voltage, smart hiccup with 3/8 duty cycle, 100°C thermal shutdown recovery	SOIC-8	Tape & Reel ¹

Note 1: Tape & Reel packing quantity is 2,500/reel. Minimum ordering quantity is 2,500.

Off-Line Digital Green-Mode Quasi-Resonant PWM Controller

Disclaimer

Information in this document is believed to be accurate and reliable. However, Dialog Semiconductor does not give any representations or warranties, expressed or implied, as to the accuracy or completeness of such information. Dialog Semiconductor furthermore takes no responsibility whatsoever for the content in this document if provided by any information source outside of Dialog Semiconductor.

Dialog Semiconductor reserves the right to change without notice the information published in this document, including without limitation the specification and the design of the related semiconductor products, software and applications.

Applications, software, and semiconductor products described in this document are for illustrative purposes only. Dialog Semiconductor makes no representation or warranty that such applications, software and semiconductor products will be suitable for the specified use without further testing or modification. Unless otherwise agreed in writing, such testing or modification is the sole responsibility of the customer and Dialog Semiconductor excludes all liability in this respect.

Customer notes that nothing in this document may be construed as a license for customer to use the Dialog Semiconductor products, software and applications referred to in this document. Such license must be separately sought by customer with Dialog Semiconductor.

All use of Dialog Semiconductor products, software and applications referred to in this document are subject to Dialog Semiconductor's [Standard Terms and Conditions of Sale](#), unless otherwise stated.

© Dialog Semiconductor. All rights reserved.

RoHS Compliance

Dialog Semiconductor complies to European Directive 2001/95/EC and from 2 January 2013 onwards to European Directive 2011/65/EU concerning Restriction of Hazardous Substances (RoHS/RoHS2).

Dialog Semiconductor's statement on RoHS can be found on the customer portal <https://support.diasemi.com/>. RoHS certificates from our suppliers are available on request.

Contacting Dialog Semiconductor

United Kingdom

Dialog Semiconductor (UK) Ltd
Phone: +44 1793 757700

Germany

Dialog Semiconductor GmbH
Phone: +49 7021 805-0

The Netherlands

Dialog Semiconductor B.V.
Phone: +31 73 640 88 22

Email

info_pcbg@diasemi.com

North America

Dialog Semiconductor Inc.
Phone: +1 408 845 8500

Japan

Dialog Semiconductor K. K.
Phone: +81 3 5425 4567

Taiwan

Dialog Semiconductor Taiwan
Phone: +886 281 786 222

Web site:

www.dialog-semiconductor.com

Singapore

Dialog Semiconductor Singapore
Phone: +65 648 499 29

Hong Kong

Dialog Semiconductor Hong Kong
Phone: +852 2607 4271

Korea

Dialog Semiconductor Korea
Phone: +82 2 3469 8200

China

*Dialog Semiconductor
(Shenzhen)*
Phone: +86 755 2981 3669

*Dialog Semiconductor
(Shanghai)*
Phone: +86 21 5424 9058