

## AC/DC Secondary-Side Synchronous Rectification and Rapid Charge™ Interface Controller for Qualcomm® Quick Charge™ 3.0

### 1 Description

The iW662 is an AC/DC secondary-side combo controller for Qualcomm® Quick Charge™ 3.0 (QC3.0) which includes USB interface, secondary-to-primary communication and synchronous rectification functions in a single IC.

The iW662 resides on the secondary side of an AC/DC power supply and allows the adapter to be configured for multi-level output voltages from 3.6V to 12V in 200mV increments, depending on the voltage requested by the mobile device (MD). It can be used in Dialog's primary-side controlled AC/DC systems to achieve fast voltage transition, low no-load power consumption, and fast dynamic load response.

The iW662 uses Dialog's proprietary XM-Comm secondary-to-primary digital communication technology. When paired with Dialog's primary-side controller, the iW1790, the optocoupler can be completely eliminated in the system. The iW662 transmits all necessary information for rapid charge through the power transformer, including output voltage requests, output current limits, output voltage undershoot, output over-voltage, and fault and reset signals.

The iW662 is also an advanced synchronous rectifier (SR) controller with an integrated MOSFET driver, enabling discontinuous mode flyback converters with high efficiency operation. The device works with an external power MOSFET to replace the main rectifying diode on the secondary of a flyback converter, improving efficiency by reducing secondary-side conduction losses. Dialog's digital adaptive turn-off control technology minimizes turn-off deadtime, eliminating the need for an additional Schottky diode that is typically needed in parallel with the synchronous MOSFET in conventional synchronous rectifiers.

The iW662 and iW1790 provide double-layer cable protection. On the secondary side, the iW662 incorporates Dialog's proprietary D+/D- over-voltage protection to address  $V_{BUS}$  D+/D- soft shorts. On the primary side, the iW1790 uses Dialog's **SmartDefender+**™ advanced hiccup technology to reduce the average output power during soft shorts without latch.

Qualcomm® Quick Charge™ 3.0 is a product of Qualcomm Technologies, Inc.

### 2 Features

- XM-Comm proprietary secondary-to-primary digital communication transmits all information for rapid charge without an optocoupler: output voltage requests, output current limits, output voltage undershoot, over-voltage protection, and other fault and reset signals
- Lossless MOSFET  $V_{DS}$  sensing for SR timing control with digital adaptive turn-off control
- Optimized 5V MOSFET gate driver
- High-voltage drain sensing up to 100V with no additional external clamping circuits required
- Supports Qualcomm® Quick Charge™ 3.0 technology High Voltage Dedicated Charging Port (HVDCP) to provide  $V_{BUS}$  from 3.6V to 12V in 200mV increments
- Double-layer cable protection:
  - » Secondary side (iW662): Proprietary D+/D- over-voltage protection (OVP) addresses  $V_{BUS}$  D+/D- soft shorts
  - » Primary side (iW1790): **SmartDefender+**™ smart hiccup technology reduces average output power at fault conditions without latch
- Adaptive OVP/UV detection for most  $V_{BUS}$  levels
- Backward compatible with QC2.0 and USB Battery Charging Specification Revision 1.2 (USB BC1.2)
- Wide operating voltage range from 3V to 16V
- Programmable active fast discharge from a high voltage to 5V at MD unplug or from a high voltage level to a lower level upon request with built-in switch or external switch
- Intelligent low power mode enables < 20mW no-load power consumption
- Dual Over-Temperature Protection (OTP) via on-chip temperature sensing circuit and external NTC (10-lead MSOP package only)
- 10-lead MSOP and 8-Lead SOIC packages

**AC/DC Secondary-Side Synchronous Rectification and Rapid Charge™ Interface Controller for Qualcomm® Quick Charge™ 3.0**

**3 Applications**

- 18W/24W QC AC/DC adapters for smart phones, tablets, and other portable devices

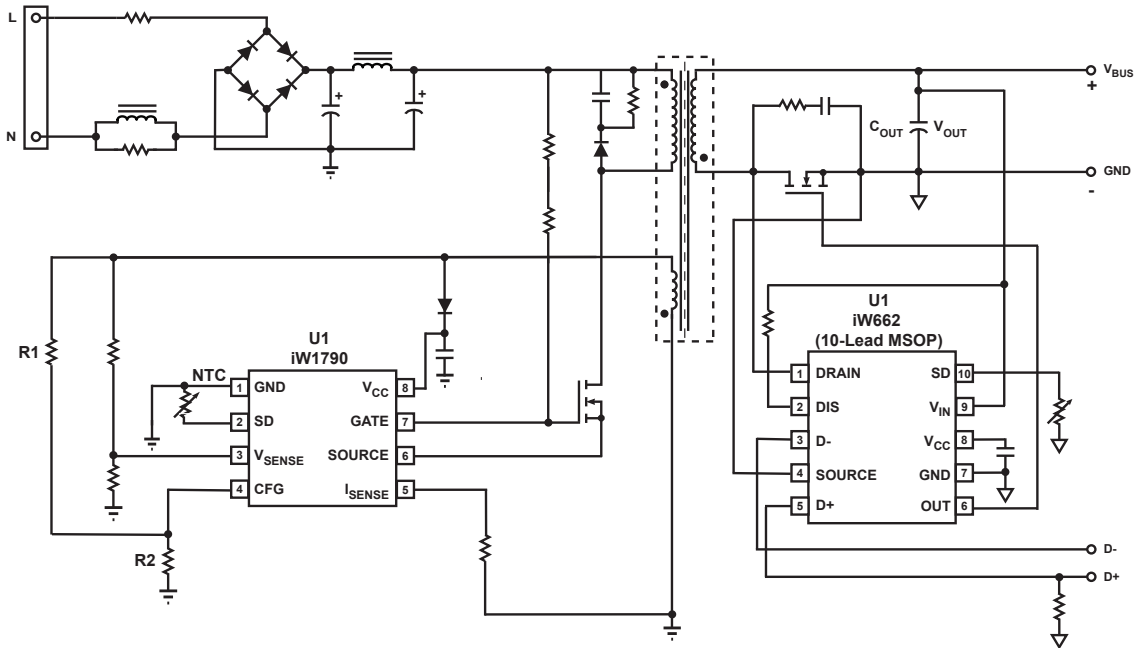

**Figure 3.1 : iW662 (10-Lead MSOP) 18W/24W Typical Application Circuit for Multi-Level Output Voltage and Current (Using iW1790 as Primary-Side Controller. Achieving < 20mW No-Load Power Consumption.)**

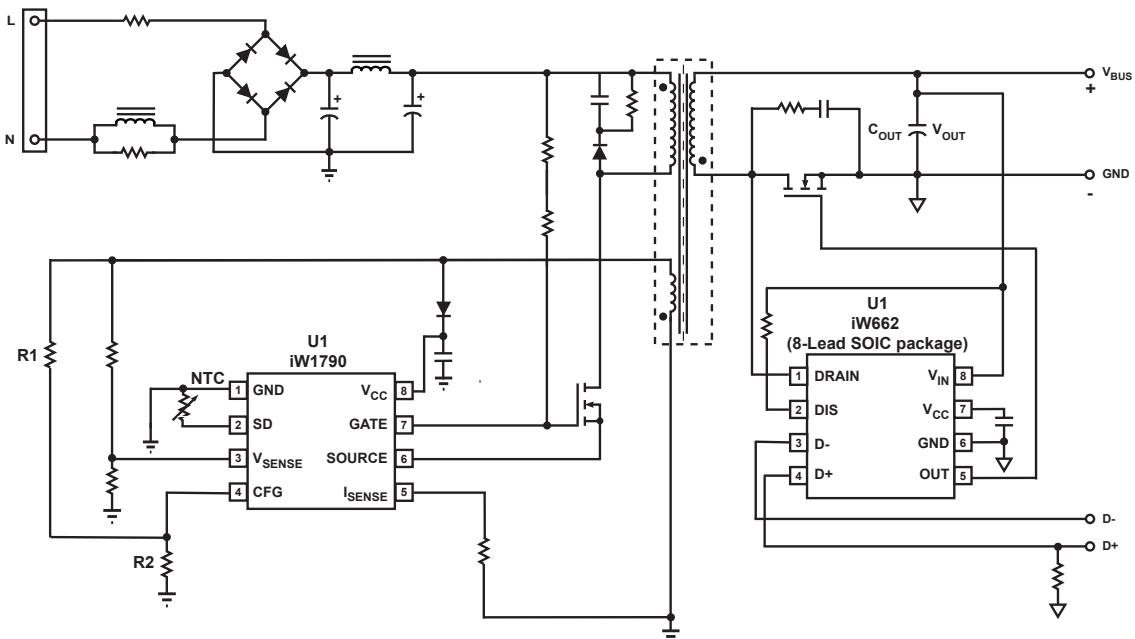

**Figure 3.2 : iW662 (8-Lead SOIC package) 18W/24W Typical Application Circuit for Multi-Level Output Voltage and Current (Using iW1790 as Primary-Side Controller. Achieving < 20mW No-Load Power Consumption.)**

## AC/DC Secondary-Side Synchronous Rectification and Rapid Charge™ Interface Controller for Qualcomm® Quick Charge™ 3.0

### 4 Pinout Description

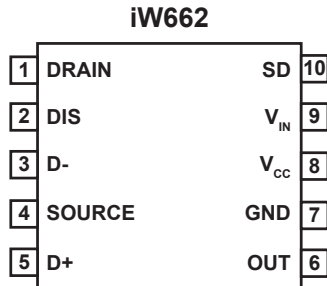

Figure 4.1 : 10-Lead MSOP Package

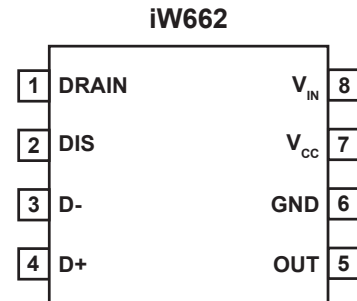

Figure 4.2 : 8-Lead SOIC Package

Pin No. (10-Lead MSOP)	Pin No. (8-Lead SOIC)	Pin Name	Type	Pin Description
1	1	DRAIN	Analog Input	Synchronous rectifier MOSFET drain voltage sensing and the Pulse Linear Regulator (PLR) input.
2	2	DIS	Analog Output	Discharging circuit. Used for fast discharging of output capacitor.
3	3	D-	Analog Input	USB D- signal.
4	—	SOURCE	Analog input	Synchronous rectifier MOSFET source voltage sensing input.
5	4	D+	Analog Input	USB D+ signal.
6	5	OUT	Output	Synchronous rectifier MOSFET driver.
7	6	GND	Ground	Ground.
8	7	V <sub>CC</sub>	Power Input	LDO and PLR output. Connect this pin to a capacitor.
9	8	V <sub>IN</sub>	Analog Input	Input of the internal LDO and output voltage sensing circuit. Connect to adapter/charger output for bias voltage. The internal LDO clamps the V <sub>CC</sub> voltage at 5V when V <sub>IN</sub> > 5V.
10	—	SD	Analog Output	External shutdown control. It can be configured for external over-temperature protection (OTP) by connecting an NTC resistor from this pin to Ground.

## AC/DC Secondary-Side Synchronous Rectification and Rapid Charge™ Interface Controller for Qualcomm® Quick Charge™ 3.0

### 5 Absolute Maximum Ratings

Absolute maximum ratings are the parameter values or ranges which can cause permanent damage if exceeded. For maximum safe operating conditions, refer to Electrical Characteristics in Section 6.

Parameter	Symbol	Value	Units
$V_{IN}$ DC supply voltage range ( $I_{CC} = 15\text{mA}$ max)	$V_{IN}$	-0.3 to 33	V
Continuous DC supply current at $V_{IN}$ pin ( $V_{IN} = 25\text{V}$ )	$I_{VO}$	15	mA
Continuous DC supply current at $V_{CC}$ pin ( $V_{CC} = 5.5\text{V}$ )	$I_{VCC}$	15	mA
Gate peak output current	$I_G$	$\pm 3$	A
DRAIN pin voltage (Note 1)	$V_D$	-1.5 to 100	V
DRAIN pin peak current	$I_{DRAIN}$	-40 to 350	mA
SOURCE pin voltage (10-Lead MSOP Package only)		-0.6 to 5	V
OUT pin voltage	$V_{OUT}$	-0.6 to $V_{CC} + 0.6$	V
$V_{CC}$ pin voltage	$V_{CC}$	-0.6 to 6	V
DIS pin voltage	$V_{DIS}$	30	V
SD pin voltage (10-Lead MSOP Package only)	$V_{SD}$	6.5	V
D+ pin voltage	$V_{D+}$	-0.3 to 7	V
D- pin voltage	$V_{D-}$	-0.3 to 7	V
Junction temperature	$T_J$	-40 to 150	°C
Storage temperature		-65 to 150	°C
ESD rating per JEDEC JESD22-A114 (D+ and D- pins)		TBD	V
ESD rating per JEDEC JESD22-A114 (all other pins)		$\pm 2,000$	V

#### Notes:

Note 1: The DRAIN pin voltage should not be below -0.6V for more than 500ns.

# AC/DC Secondary-Side Synchronous Rectification and Rapid Charge™ Interface Controller for Qualcomm® Quick Charge™ 3.0

## 6 Physical Dimensions

### 6.1 10-Lead MSOP Package

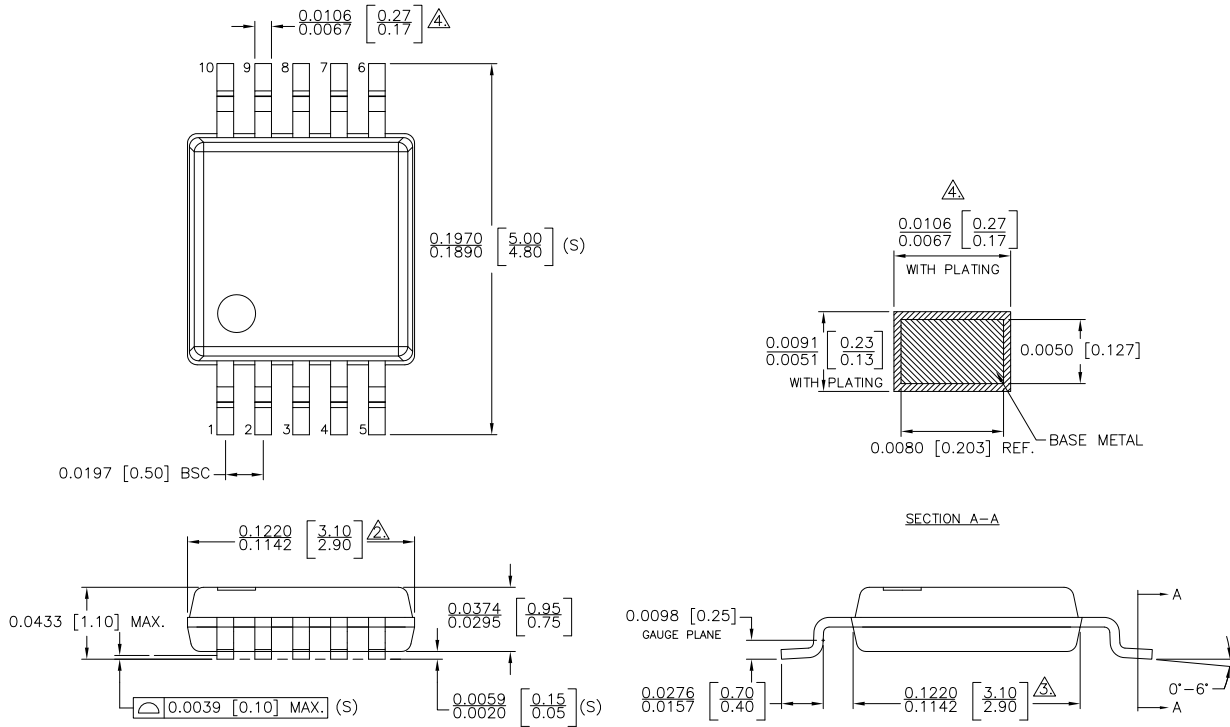

**NOTE :**

1. PACKAGE DIMENSIONS CONFORM TO JEDEC SPECIFICATION MO-187 BA.
- △ DOES NOT INCLUDE MOLD FLASH, PROTRUSION OR GATE BURRS. MOLD FLASH, PROTRUSIONS OR GATE BURRS SHALL NOT EXCEED 0.15 mm. PER SIDE.
- △ DOES NOT INCLUDE INTERLEAD FLASH OR PROTRUSION. INTERLEAD FLASH OR PROTRUSION SHALL NOT EXCEED 0.15 mm. PER SIDE.
- △ DOES NOT INCLUDE DAMBAR PROTRUSION. ALLOWABLE DAMBAR PROTRUSION SHALL BE 0.08 MM.
5. LEAD SPAN/STAND OFF HEIGHT/COPLANARITY ARE CONSIDERED AS SPECIAL CHARACTERISTIC(S)
6. CONTROLLING DIMENSIONS IN INCHES. [mm]

STATUS: RELEASED	SCALE: DO NOT SCALE	
TERMINAL FINISH: 100% Sn or NiPdAg		
TITLE: 10 MSOP PACKAGE OUTLINE		
REV: B	REVISION NOTE: TERMINAL FINISH UPDATED	DATE: 26-OCT-2016

**AC/DC Secondary-Side Synchronous Rectification and Rapid Charge™ Interface Controller for Qualcomm® Quick Charge™ 3.0**

**6.2 8-Lead SOIC Package**

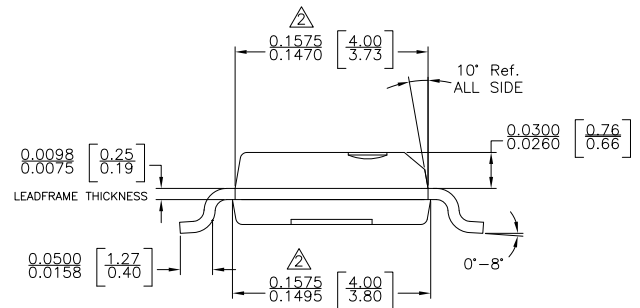
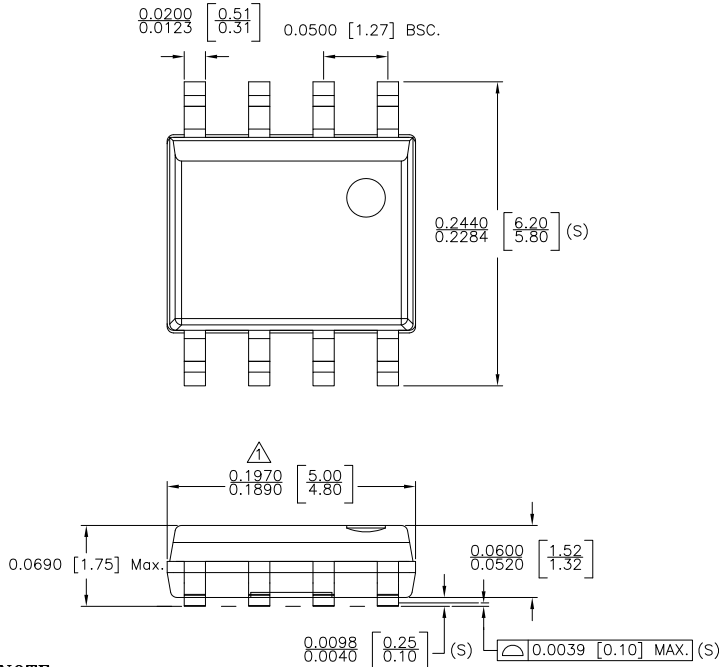

**NOTE :**

- 1. DOES NOT INCLUDE MOLD FLASH, PROTRUSIONS OR GATE BURRS. MOLD FLASH, PROTRUSIONS AND GATE BURRS SHALL NOT EXCEED .006 INCH PER SIDE.
- 2. DOES NOT INCLUDE INTER-LEAD FLASH OR PROTRUSIONS. INTER-LEAD FLASH AND PROTRUSIONS SHALL NOT EXCEED .010 INCH PER SIDE.
- 3. THIS PART IS COMPLIANT WITH JEDEC SPECIFICATION MS-012.
- 4. LEAD SPAN/STAND OFF HEIGHT/COPLANARITY ARE CONSIDERED AS SPECIAL CHARACTERISTIC(S)
- 5. CONTROLLING DIMENSIONS IN INCHES. [mm]

STATUS: RELEASED	SCALE: DO NOT SCALE
TERMINAL FINISH: 100% Sn or NiPdAu (PPF)	
TITLE: 8 SOIC PACKAGE OUTLINE	
REV: A	DATE: 02-MAR-2015

## AC/DC Secondary-Side Synchronous Rectification and Rapid Charge™ Interface Controller for Qualcomm® Quick Charge™ 3.0

### 7 Ordering Information

Part no.	Options				Package	Description
	V <sub>BUS</sub> Range	k <sub>CC</sub>	Primary-Side Controller	OVP Level		
iW662-00	3.6V to 12V	0.422 for V <sub>BUS</sub> = 3.6V to 8V Determined by constant max power for 8.2V to 12V	iW1790-08	Note 1	MSOP-10	Tape & Reel <sup>2</sup>
iW662-01	3.6V to 12V	0.5 for V <sub>BUS</sub> = 3.6V to 6V Determined by constant max power for 6.2V to 12V	iW1790-09	Note 1	MSOP-10	Tape & Reel <sup>2</sup>
iW662-02	3.6V to 12V	0.5 for V <sub>BUS</sub> = 3.6V to 8V Determined by constant max power for 8.2V to 12V	iW1790-09	Note 1	MSOP-10	Tape & Reel <sup>2</sup>
iW662-03	3.6V to 12V	0.5 for V <sub>BUS</sub> = 3.6V to 6V Determined by constant max power for 6.2V to 12V	iW1790-19	14.76V	MSOP-10	Tape & Reel <sup>2</sup>
iW662-00-SO8	3.6V to 12V	0.422 for V <sub>BUS</sub> = 3.6V to 8V Determined by constant max power for 8.2V to 12V	iW1790-08	Note 1	SOIC-8	Tape & Reel <sup>2</sup>
iW662-01-SO8	3.6V to 12V	0.5 for V <sub>BUS</sub> = 3.6V to 6V Determined by constant max power for 6.2V to 12V	iW1790-09	Note 1	SOIC-8	Tape & Reel <sup>2</sup>
iW662-02-SO8	3.6V to 12V	0.5 for V <sub>BUS</sub> = 3.6V to 8V Determined by constant max power for 8.2V to 12V	iW1790-09	Note 1	SOIC-8	Tape & Reel <sup>2</sup>
iW662-03-SO8	3.6V to 12V	0.5 for V <sub>BUS</sub> = 3.6V to 6V Determined by constant max power for 6.2V to 12V	iW1790-19	14.76V	SOIC-8	Tape & Reel <sup>2</sup>
iW662-05-SO8 <sup>3</sup>	3.6V to 9V	0.422 for V <sub>BUS</sub> = 3.6V to 9V	iW1790-08	Note 1	SOIC-8	Tape & Reel <sup>2</sup>
iW662-18-SO8 <sup>3</sup>	3.6V to 9V	0.422 for V <sub>BUS</sub> = 3.6V to 9V	iW1790-18	11.07V	SOIC-8	Tape & Reel <sup>2</sup>

**Note 1:** The OVP threshold is adjusted according to the nominal output voltage. For details, see the Discharge/UV/OV section of the electrical characteristics table in section 6.

**Note 2:** Tape & Reel packing quantity is 2,500/reel. Minimum packing quantity is 2,500.

**Note 3:** The iW662-05 option is a customized product option with 12V disabled. Adapters designed with this product option may not pass QC2.0 HVDCP compliancy test.

## AC/DC Secondary-Side Synchronous Rectification and Rapid Charge™ Interface Controller for Qualcomm® Quick Charge™ 3.0

### Disclaimer

Information in this document is believed to be accurate and reliable. However, Dialog Semiconductor does not give any representations or warranties, expressed or implied, as to the accuracy or completeness of such information. Dialog Semiconductor furthermore takes no responsibility whatsoever for the content in this document if provided by any information source outside of Dialog Semiconductor.

Dialog Semiconductor reserves the right to change without notice the information published in this document, including without limitation the specification and the design of the related semiconductor products, software and applications.

Applications, software, and semiconductor products described in this document are for illustrative purposes only. Dialog Semiconductor makes no representation or warranty that such applications, software and semiconductor products will be suitable for the specified use without further testing or modification. Unless otherwise agreed in writing, such testing or modification is the sole responsibility of the customer and Dialog Semiconductor excludes all liability in this respect.

Customer notes that nothing in this document may be construed as a license for customer to use the Dialog Semiconductor products, software and applications referred to in this document. Such license must be separately sought by customer with Dialog Semiconductor.

All use of Dialog Semiconductor products, software and applications referred to in this document are subject to [Dialog Semiconductor's Standard Terms and Conditions of Sale](#), available on the company website ([www.dialog-semiconductor.com](http://www.dialog-semiconductor.com)) unless otherwise stated.

Dialog and the Dialog logo are trademarks of Dialog Semiconductor plc or its subsidiaries. All other product or service names are the property of their respective owners.

Qualcomm is a trademark of Qualcomm Incorporated, registered in the United States and other countries. Qualcomm Quick Charge is a trademark of Qualcomm Incorporated. All Qualcomm Incorporated marks are used with permission.

© 2017 Dialog Semiconductor. All rights reserved.

### RoHS Compliance

Dialog Semiconductor's suppliers certify that its products are in compliance with the requirements of Directive 2011/65/EU of the European Parliament on the restriction of the use of certain hazardous substances in electrical and electronic equipment. RoHS certificates from our suppliers are available on request.

## Contacting Dialog Semiconductor

**United Kingdom (Headquarters)**  
Dialog Semiconductor (UK) LTD  
Phone: +44 1793 757700

**Germany**  
Dialog Semiconductor GmbH  
Phone: +49 7021 805-0

**The Netherlands**  
Dialog Semiconductor B.V.  
Phone: +31 73 640 8822

**Email**  
[info\\_pcbg@diasemi.com](mailto:info_pcbg@diasemi.com)

**North America**  
Dialog Semiconductor Inc.  
Phone: +1 408 845 8500

**Japan**  
Dialog Semiconductor K. K.  
Phone: +81 3 5769 5100

**Taiwan**  
Dialog Semiconductor Taiwan  
Phone: +886 281 786 222

**Web site:**  
[www.dialog-semiconductor.com](http://www.dialog-semiconductor.com)

**Hong Kong**  
Dialog Semiconductor Hong Kong  
Phone: +852 2607 4271

**Korea**  
Dialog Semiconductor Korea  
Phone: +82 2 3469 8200

**China (Shenzhen)**  
Dialog Semiconductor China  
Phone: +86 755 2981 3669

**China (Shanghai)**  
Dialog Semiconductor China  
Phone: +86 21 5424 9058