

Patents Pending

13715 Alton Pkwy • Irvine • CA • 92618

Tel: 949.610.0008 • Fax: 949.610.0009

www.rfdigital.com • sales@rfdigital.com

ETSI • CE Compliant

RoHS

nRF24LE1 RF Modules

RFD21731 • RFD21732 • RFD21734 • RFD21736

(Also see FCC Approved part number: RFD21733)

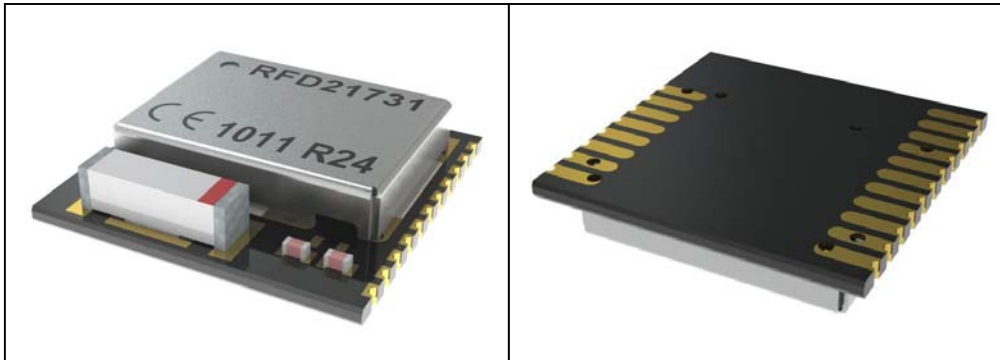

RFD21731

15mm x 15mm • 0.600 inch x 0.600 inch

Complete ultra-low-power wireless system-in-module.
With built-in mixed signal flash microcontroller and advanced power management. **NO RF Designing Required. NO parts required.**



- w/ 32KHz Crystal
- Built-in Antenna

RFD21732



- w/ 32KHz Crystal
- Req. Ext. Antenna

RFD21734

Modular ultra low power wireless

Ultra low power wireless system-on-chip solution

The RFD21731, RFD21732, RFD21734 modules are a unique solution offering a complete ultra low power (ULP) wireless system-in-module solution. It integrates the nRF24LE1 radio+controller which is based on the industry leading nRF24L01+ 2.4GHz transceiver core, an enhanced 8051 microcontroller, flash memory and a wide range of analog and digital peripherals. The 8-bit microcontroller is powerful enough to run both the RF protocol stack and the application layer, enabling a true single chip implementation of ULP wireless applications.

Optimized for ultra low power wireless

Advanced power management and on-chip peripherals

The RFD21731, RFD21732, RFD21734s internal nRF24LE1 chip is optimized to provide a single chip solution for ULP wireless applications. The combination of processing power, memory, low power oscillators, real-time counter, AES encryption accelerator, random generator, plus a range of power saving modes provides an ideal platform for implementation of RF Protocols. Benefits include tighter protocol timing, security, lower power consumption and improved co-existence performance. For the application layer the nRF24LE1 offers a rich set of peripherals including: SPI, 2-wire, UART, 6 to 12-bit ADC, PWM, and an ultra low power analog comparator for voltage level system wake-up.

If you do not want to do any development at all, then use **RFD21733 (FCC Approved)/RFD21735** which are **READY-TO-USE** with its built-in user application interface (RFDP8). Includes RFID, Unique Electronic Serial Number, Logic Switch Transmitter Receiver. Serial UART 9600-8N1 and many easy-to-use addressable network modes.

Development Tools

The RFD21731, RFD21732, RFD21734 requires the user to write their own code to run on the built-in internal enhanced 8051 controller which allows tremendous flexibility to the engineer to realize their exact requirements, which requires the purchase of Nordic's nRFgo Starter Kit development environment in addition to at least one (preferred 2) RFD21736 adaptor module boards for use with the nRFgo.

NO Dev-Tools Option:

The **READY-TO-USE** RFD21733 / RFD21735 do not require any development tools.

Patents Pending

13715 Alton Pkwy • Irvine • CA • 92618

Tel: 949.610.0008 • Fax: 949.610.0009

www.rfdigital.com • sales@rfdigital.com

ETSI • CE Compliant

RoHS

RFD21732 / RFD21734 Pinout Chart (TOP VIEW)

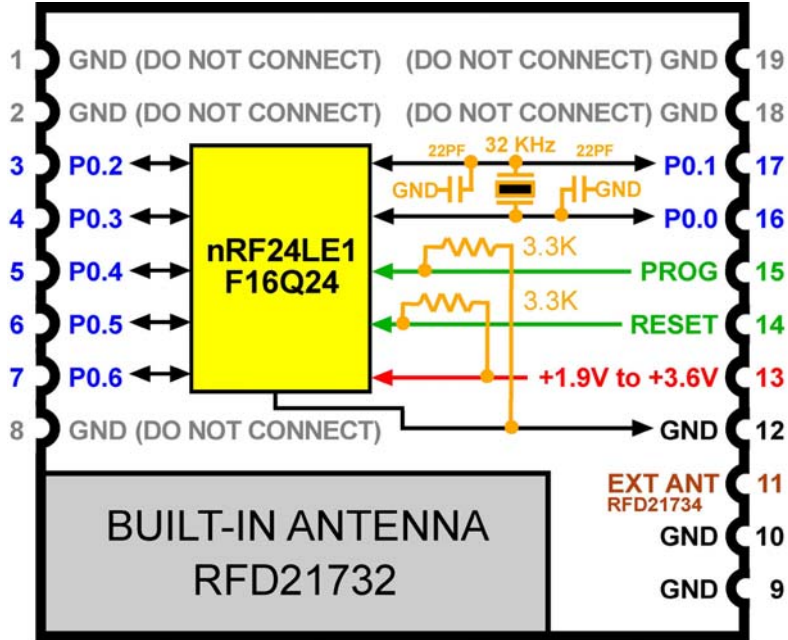

RFD21732 Signals

**Built In Antenna
32 KHz Crystal**

+1.9 to 3.6V
GND
P0.0 (RFD21732 32KHz)
P0.1 (RFD21732 32KHz)
P0.2
P0.3
P0.4
P0.5
P0.6
RESET
PROG

RFD21734 Signals

**No Internal Antenna
32 KHz Crystal**

+1.9 to 3.6V
GND
P0.0 (RFD21732 32KHz)
P0.1 (RFD21732 32KHz)
P0.2
P0.3
P0.4
P0.5
P0.6
RESET
PROG
External Antenna Pin

RFD21731 Pinout Chart (TOP VIEW)

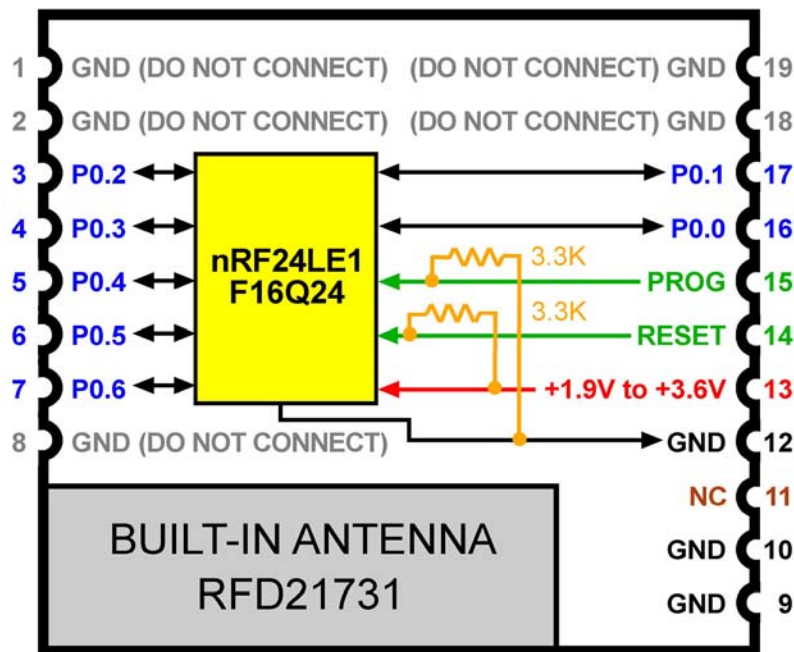

RFD21731 Signals

**Built In Antenna
No 32 KHz Crystal**

+1.9 to 3.6V
GND
P0.0
P0.1
P0.2
P0.3
P0.4
P0.5
P0.6
RESET
PROG

Patents Pending

13715 Alton Pkwy • Irvine • CA • 92618

Tel: 949.610.0008 • Fax: 949.610.0009

www.rfdigital.com • sales@rfdigital.com

ETSI • CE Compliant

RoHS

RFD21731, RFD21732, RFD21734 Features

- **NO RF parts or layout required, fully contained, easy access to all digital lines.**
- Typical outdoor range 300 feet (100 meters)
- 125 channels, 2400 to 2525 MHz.
- Current draw: 11.1 mA at 0 dBm Transmit, 13.3 mA at -94 dBm Receive.
- Fully featured ultra low power nRF24L01+ 2.4GHz transceiver core
- Worldwide 2.4GHz ISM band operation
- Enhanced ShockBurst™ hardware link layer
- 250 kbps, 1 Mbps and 2 Mbps on-air data rate options.
- Air compatible with nRF24L01, nRF24L01+, nRF24LU1 and nRF2401A
- Enhanced 8-bit 8051 compatible microcontroller
- 32-bit multiplication-division unit
- AES encryption/decryption accelerator
- 16 kbytes on-chip flash memory
- 1 kbyte on-chip data flash memory
- 512 bytes high-endurance data flash memory
- 1 kbyte on SRAM plus 256 bytes of IRAM
- Low power 16MHz crystal and RC oscillators
- Ultra low power 32kHz crystal and RC oscillators
- Flexible real-time counter and three 16-bit timers/counters
- Ultra low power analog comparator for system wake-up
- Rich set of digital interfaces including: SPI master/slave, 2-wire master/slave, and UART
- 2-channel PWM
- Programmable resolution ADC: 6, 8, 10, or 12-bits
- Random Number Generator based on thermal noise
- 7 Programmable generic I/O pins

RFDP8 Option

RF Digital's RFDP8 high level application protocol firmware which runs on the nRF24LE1-F16Q24 is available pre-loaded on the RFD21733 / RFD21735, ideal for those who don't have time to write code.

So if you don't want to do any development at all, then use RFD21733 / RFD21735 which are **READY-TO-USE** with its built-in user application interface (RFDP8). Includes RFID, Unique Electronic Serial Number, Logic Switch Transmitter / Receiver, Serial UART 9600-8N1 and many easy-to-use addressable network modes.

RFD21736 Eval adaptor board for nRFgo Starter Kit

The RFD21736 has a built-in RFD21731 and it plugs directly into Nordic's nRF6700 nRFgo Starter Kit board which is required to use the RFD21736. The RFD21736 has an on-board user switchable 32 KHz crystal, which allows evaluation of the RFD21732. **(nRF6700 Required)** You should **ONLY** use the RFD21736 and nRF6700 if you will be writing your own RF firmware, otherwise you should use the **READY-TO-USE** RFD21733, RFD21735, RFD21737.



RFD21736 Top View

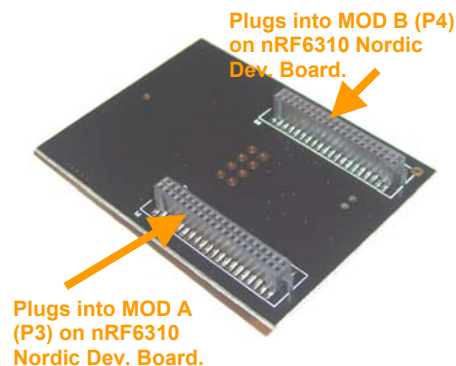

RFD21736 Bottom View

Accessible Pins

+1.9 to 3.6V
GND
P0.0 Optional 32KHz
P0.1 Optional 32KHz
P0.2
P0.3
P0.4
P0.5
P0.6
RESET
PROG
**With Switchable
32 KHz Crystal**

RFD21764 RFDANT Eval adaptor board for nRFgo Starter Kit

The RFD21764 includes an RFD21741 RFDANT which plugs into the RFD21764 board which plugs directly into Nordic's nRF6700 nRFgo Starter Kit board which is required to use the RFD21764. The 32 KHz crystal is populated on the RFD21764 but unused. **(nRF6700 Required)** You should **ONLY** use the RFD21764 and nRF6700 if you will be writing your own RF firmware, otherwise you should use the **READY-TO-USE** RFD21743 or RFD21742.

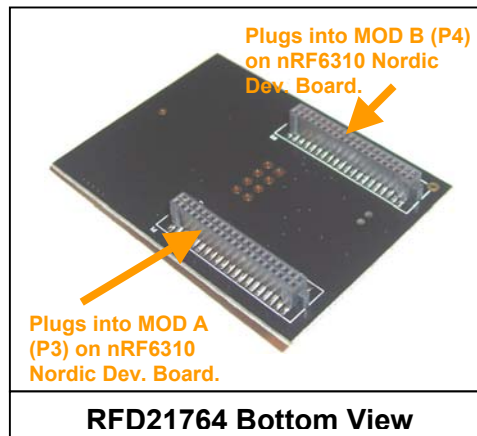
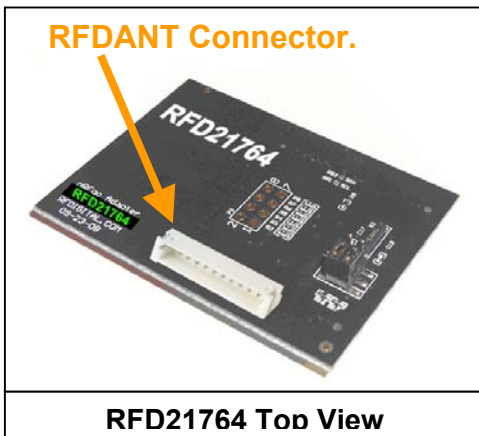

Accessible Pins
+1.9 to 3.6V
GND
P0.0 Optional 32KHz
P0.1 Optional 32KHz
P0.2
P0.3
P0.4
P0.5
P0.6
RESET
PROG



RFDP8 Option

RF Digital's RFDP8 high level application protocol firmware which runs on the nRF24LE1-F16Q24 is available pre-loaded on the RFD21742 / RFD21743, ideal for those who don't have time to write code.

So if you don't want to do any development at all, then use RFD21743 / RFD21742 which are **READY-TO-USE** with its built-in user application interface (RFDP8). Includes RFID, Unique Electronic Serial Number, Logic Switch Transmitter / Receiver, Serial UART 9600-8N1 and many easy-to-use addressable network modes.

Patents Pending

13715 Alton Pkwy • Irvine • CA • 92618

Tel: 949.610.0008 • Fax: 949.610.0009

www.rfdigital.com • sales@rfdigital.com

ETSI • CE Compliant

RoHS

RFDANT - RFD21741

The RFD21741 RFDANT is a full nRF24LE1 2.4 GHz radio transceiver, completely built into an antenna form factor allowing the entire radio transceiver to be outside your product, were only the power and signal cable will extend into your product enclosure to then be connected to your PCB with a simple 1.5mm SMT or THROUGH HOLE connector.

The RFD21741 RFDANT is currently available, as well as it's eval and programming board which is the RFD21764. The RFD21764 plugs into the Nordic nRFgo development board for programming and evaluation. The RFD21741 is functionally identical to the RFD21731 module and the RFD21764 works just like the RFD21736 eval board except it has an 11 pin 1.5mm connector on it so the RFDANT RFD21741 can plug into it for use with any other nRF24LE1 product running your own code.

The RFD21741 has been range tested at 2,000 feet which is 4x the range of the RFD21731 which is at 500 feet. No special PCB layout is needed for the RFD21741, simply just put a connector on your PCB and you are done . All this substantial range increase is achieved all without any increase in current or battery consumption.

The 2,000 foot range test was done using RF Digital's RFDP8 protocol running at 250 kbps and 0dbm power setting with the nRF24LE1.

The RFDANT is RF Digital's Worldwide Patent Pending Radio Inside Antenna product, which is a complete radio transceiver and antenna mounted inside of an antenna enclosure, suitable for mounting to virtually any type of end-product.

The entire radio transceiver is mounted inside the antenna enclosure, so there is no loss of RF power to the antenna from the module, and results in the most effective power transfer ratio possible, providing lowest power consumption possible to achieve a specific range.

The radio being inside of the antenna and outside the enclosure allows for more room inside the enclosure for the designers application electronics.

Minimal interference with the internal electronics of the enclosure results in better range and performance of the wireless system.

The actual effective antenna is pushed away from the enclosure, which reduces the effect of holding the enclosure, therefore improving the performance, range and predictability of the users wireless system.

Logic level signals are used through an unshielded cable (not coax) to the RFDANT, which can be run for long distances without any loss to the performance of the wireless transceiver.

By the antenna and module being fully outside allows for easy retrofit of nearly any product due to it not consuming any internal space inside the enclosure, drill a hole and screw it in, add a nut inside to secure it and wire the logic level signals to your electronics.

Mount on metal or plastic enclosures with no worry about ground effects.

Stable Antenna Pattern providing substantial, well-distributed, passive-gain for transmit and receive, results longer repeatable range from your wireless system.

Patents Pending

13715 Alton Pkwy • Irvine • CA • 92618

Tel: 949.610.0008 • Fax: 949.610.0009

www.rfdigital.com • sales@rfdigital.com

RoHS

RFDANT - RFD21741 - ETSI • CE

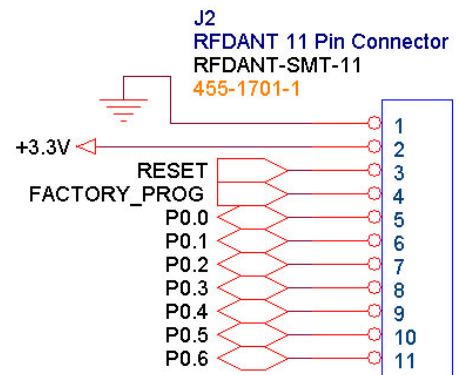
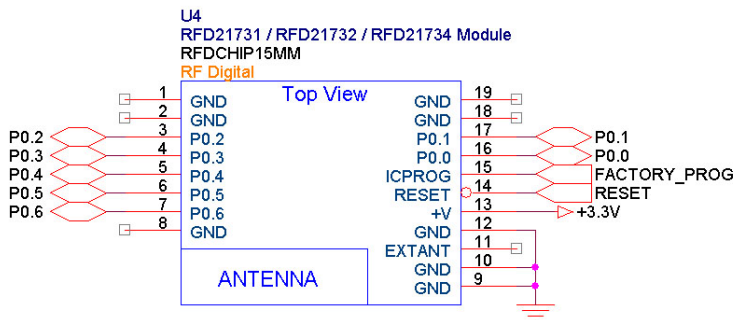

The pin out, on the left is of the RFD21731 / RFD21732 / RFD21734 module which is referenced through out this document. To wire the RFDANT 11 pin connector, match up the pin labels shown in both drawings above. Treat the RFDANT RFD21741 as if it were an RFD21731 module and wire it the same way, except follow the pin outs shown above. The BLACK wire on the RFD21741 connector is pin 1.

Patents Pending

13715 Alton Pkwy • Irvine • CA • 92618

Tel: 949.610.0008 • Fax: 949.610.0009

www.rfdigital.com • sales@rfdigital.com

ETSI • CE Compliant

RoHS

RFDANT - RFD21741 Mating Connectors

Mating connectors for the 11 pin RFDANT connector, these part numbers can be found at Digikey in the USA <http://www.digikey.com> or at any other distributor. They are standard connectors and you may use other manufacturers as well.

- 1) Top Entry, Through Hole Type, 11 pos
 - a. Digikey P/N 455-1666-ND
 - b. Manufacturer P/N: B11B--ZR

- 2) Side Entry, Through Hole Type, 11 pos
 - a. Digikey P/N 455-1678-ND
 - b. Manufacturer P/N: S11B--ZR

- 3) Top Entry, SMT Type, 11 pos
 - a. Digikey P/N 455-1690-2-ND
 - b. Manufacturer P/N: B11B—ZR-SM4-TF

- 4) Side Entry, SMT Type, 11 pos
 - a. Digikey P/N 455-1701-2-ND
 - b. Manufacturer P/N: S11B—ZR-SM4-TF

Patents Pending

13715 Alton Pkwy • Irvine • CA • 92618

Tel: 949.610.0008 • Fax: 949.610.0009

www.rfdigital.com • sales@rfdigital.com

ETSI • CE Compliant

RoHS

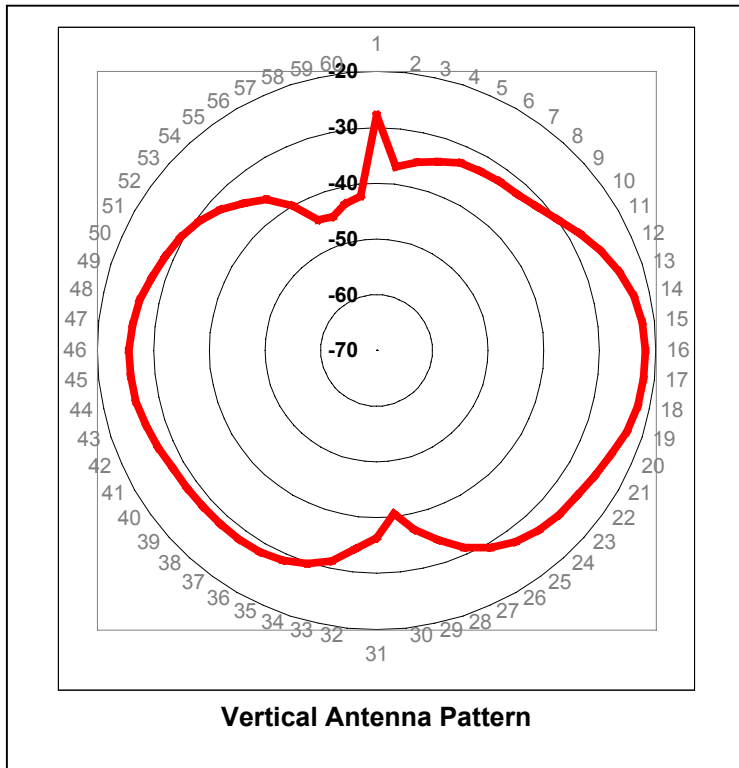
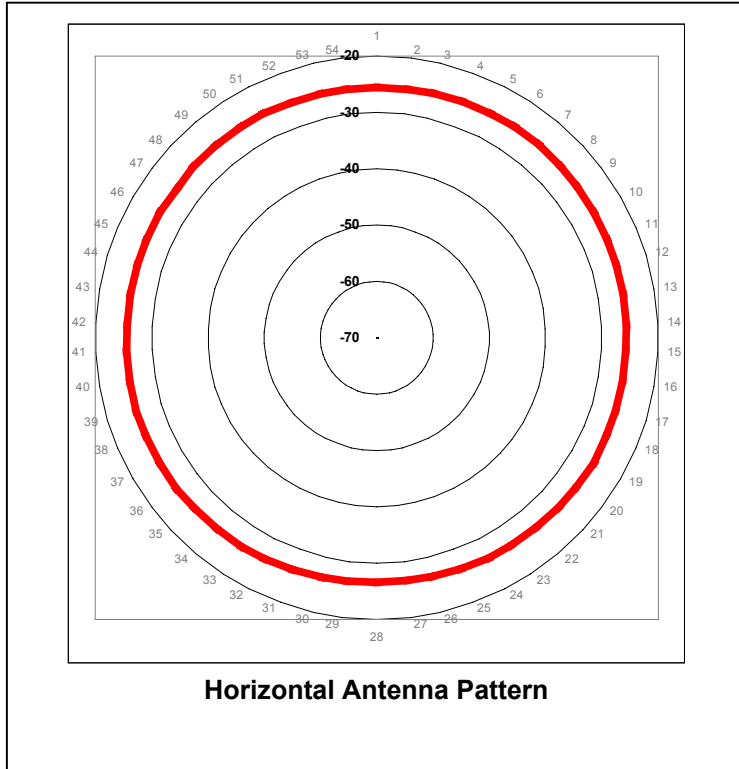

RFDANT RFD21741 high performance antenna patterns are easily achieved without any RF considerations or knowledge because the 11 pin cable and connector only carries power and data signals so NO RF cable loss at all.



Patents Pending

13715 Alton Pkwy • Irvine • CA • 92618

Tel: 949.610.0008 • Fax: 949.610.0009

RoHS

www.rfdigital.com • sales@rfdigital.com

ETSI • CE Compliant

RFD21736 Schematic (plugs onto the nRF6310 eval board)

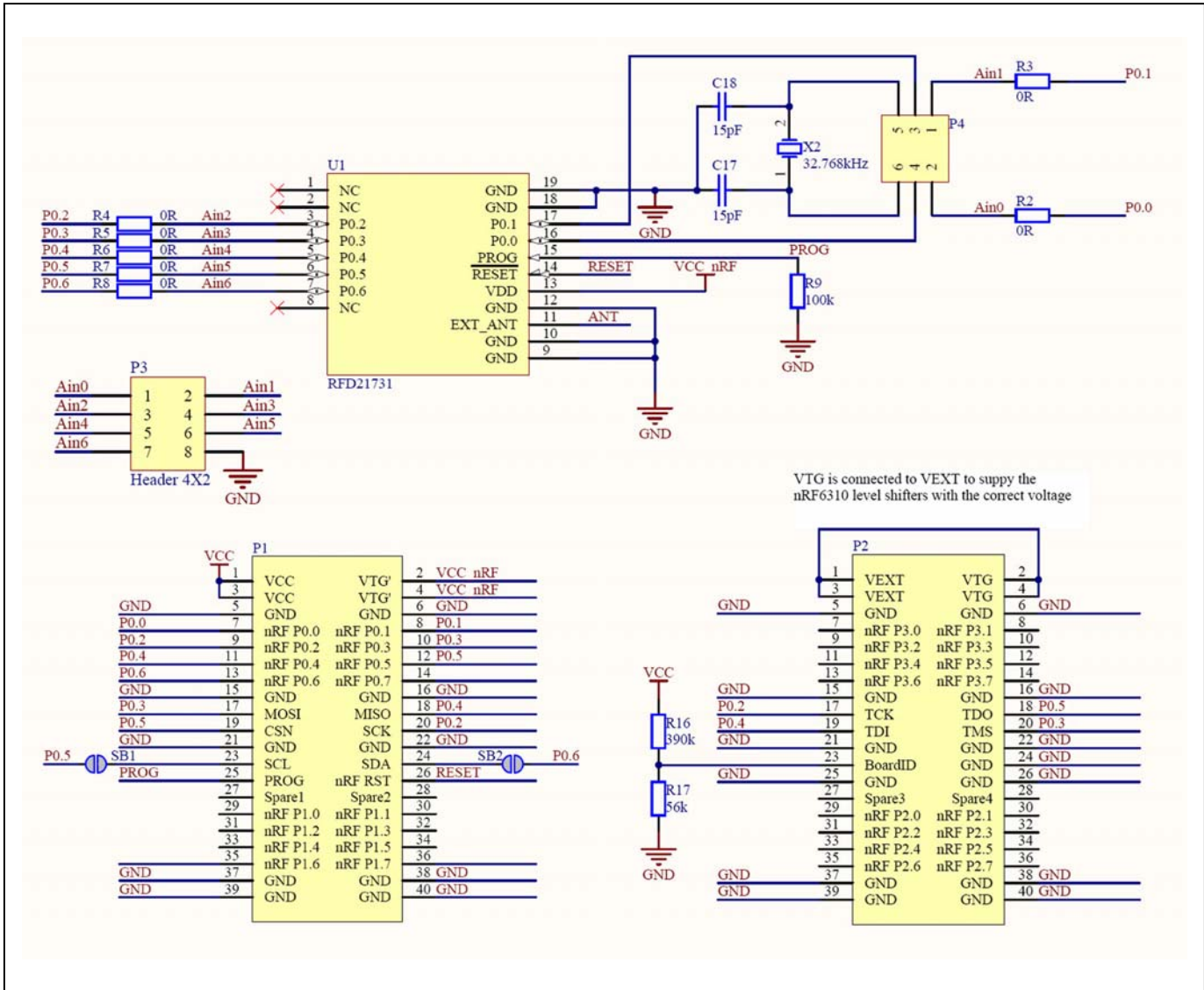

The 390k and 56k voltage divider sets a specific voltage which will be read by the programming board that tells it which of the three possible options of nRF24LE1 ICs are plugged into the nRF6310 development (programming) board. The RFD21736 has an RFD21731 mounted on it, which uses the 24 pin 4x4mm nRF24LE1 from Nordic, the other 2 options which it does not use are the 5mm and 7mm options.

In the schematic above, P1 on the RFD21736 plugs into MOD A (P3) on the nRF6310 programming board.
In the schematic above, P2 on the RFD21736 plugs into MOD B (P4) on the nRF6310 programming board.

[The Nordic nRF6310 development and programming board schematic is attached at the end of this document.](#)

Patents Pending

13715 Alton Pkwy • Irvine • CA • 92618

Tel: 949.610.0008 • Fax: 949.610.0009

www.rfdigital.com • sales@rfdigital.com

ETSI • CE Compliant

RoHS

RFD21736 Layout (plugs onto the nRF6310 eval board)

Top Layer Silk Screen

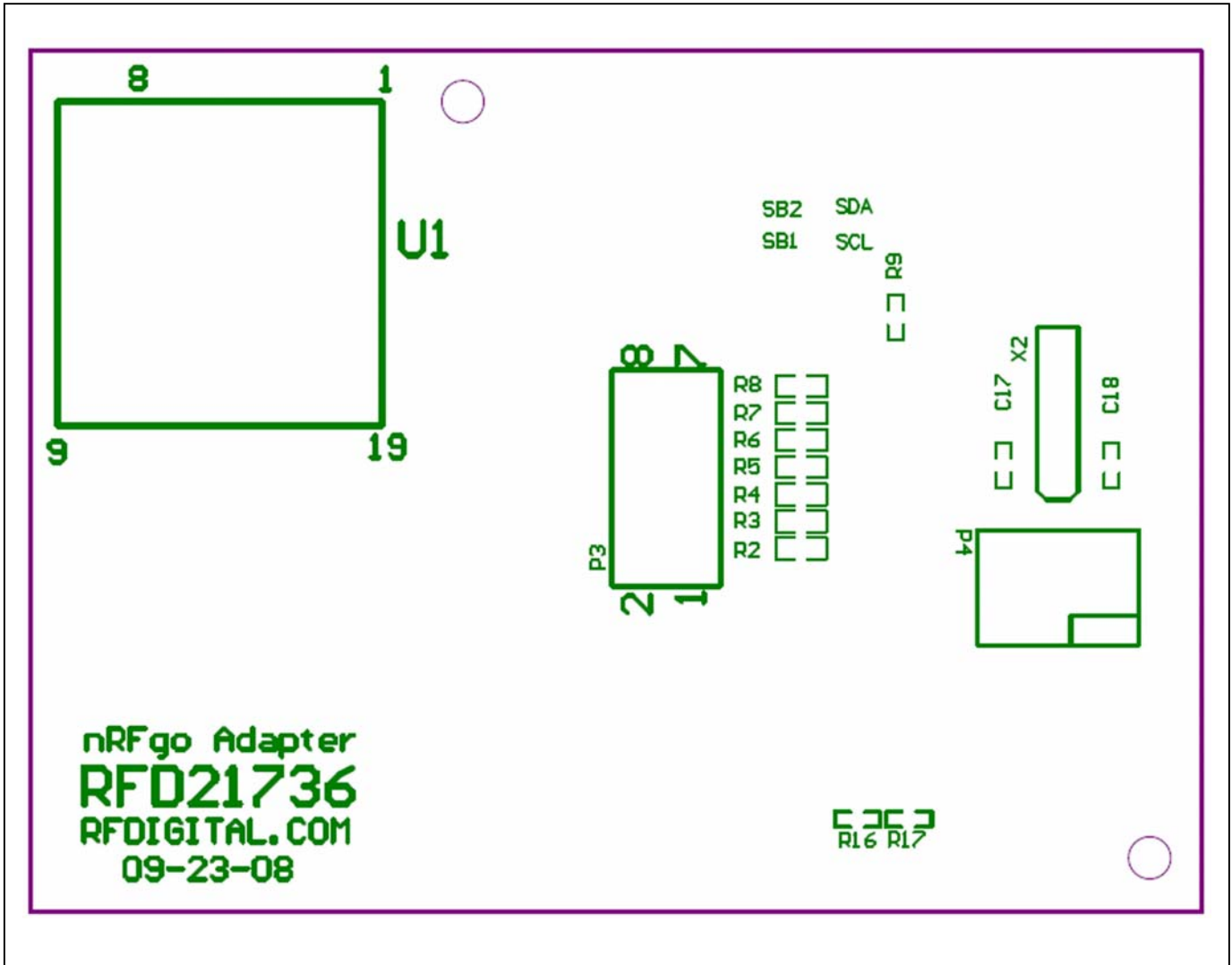

Patents Pending

13715 Alton Pkwy • Irvine • CA • 92618

Tel: 949.610.0008 • Fax: 949.610.0009

www.rfdigital.com • sales@rfdigital.com

ETSI • CE Compliant

RoHS

RFD21736 Layout (plugs onto the nRF6310 eval board)

Top Layer Copper

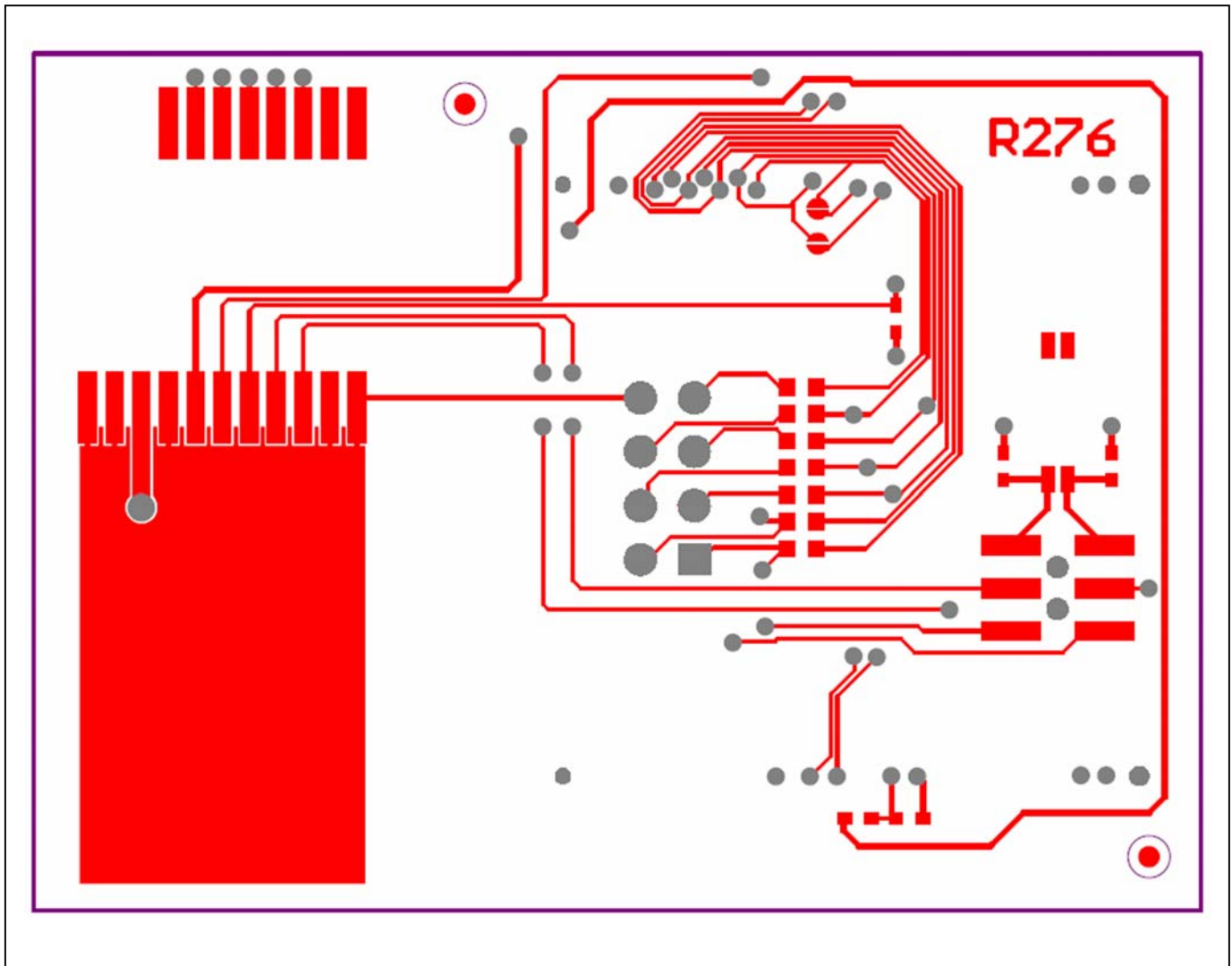

Patents Pending

13715 Alton Pkwy • Irvine • CA • 92618

Tel: 949.610.0008 • Fax: 949.610.0009

www.rfdigital.com • sales@rfdigital.com

ETSI • CE Compliant

RoHS

RFD21736 Layout (plugs onto the nRF6310 eval board)

Bottom Layer Copper (reversed - viewed through the PCB)

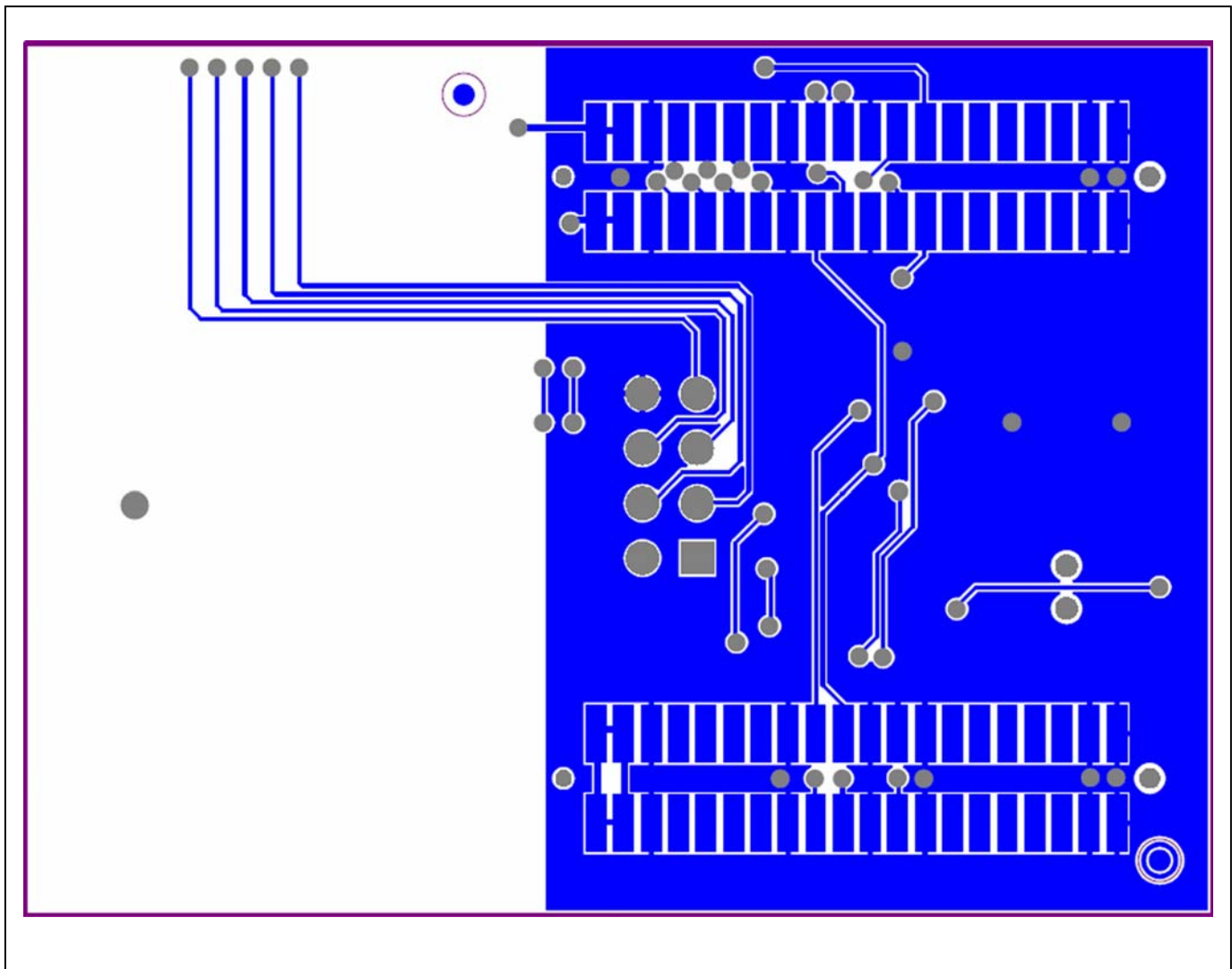

Patents Pending

13715 Alton Pkwy • Irvine • CA • 92618

Tel: 949.610.0008 • Fax: 949.610.0009

www.rfdigital.com • sales@rfdigital.com

ETSI • CE Compliant

RoHS

RFD21736 Layout (plugs onto the nRF6310 eval board)

Bottom Layer Silk Screen (reversed - viewed through the PCB)

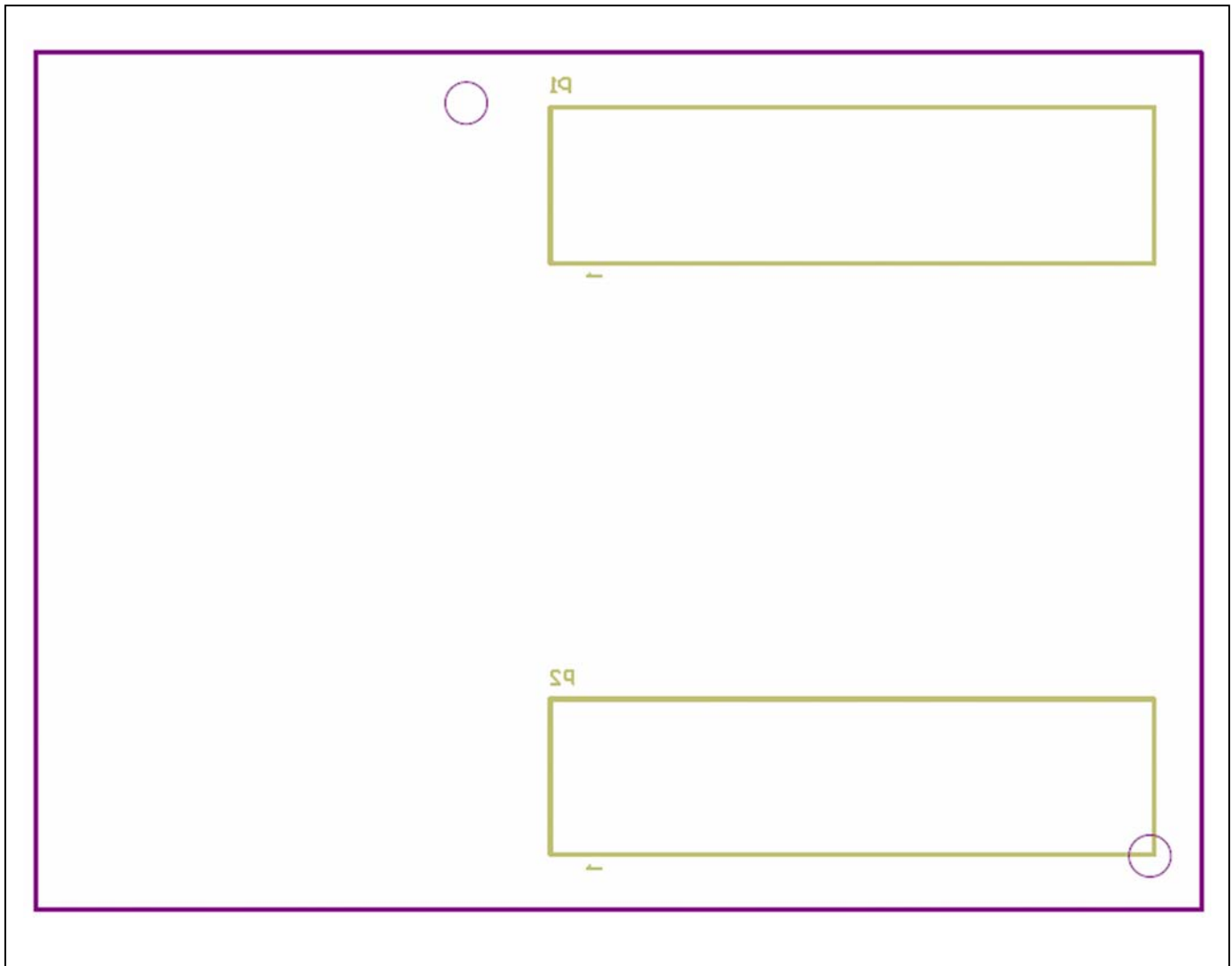

Patents Pending

13715 Alton Pkwy • Irvine • CA • 92618

Tel: 949.610.0008 • Fax: 949.610.0009

www.rfdigital.com • sales@rfdigital.com

ETSI • CE Compliant

RoHS

Nordic's nRF6700 nRFGo Starter Kit (Required)



Nordic nRFGo Board nRF6700

The nRF6700 nRFGo Starter Kit from Nordic comes with 2 nRF6700 development boards so you can have a complete communication system between at least 2 points.

The nRF6700 nRFGo Starter Kit is not complete. It requires one of three nRF24LE1 Development Kits from Nordic, which are radio boards that actually contain the nRF24LE1 IC. The difference between the three kits are which of the 3 flavors of IC are mounted on the boards in the kit. The IC that is inside RF Digital's module is the nRF24LE1-F16Q24. The Nordic radio board kit part number which represents the RF Digital module is the nRF24LE1-F16Q24-DK. Nordic's nRF24LE1-F16Q24-DK includes 3 radio boards, enough for a complete system.

RF Digital's RFD21736 radio board is sold individually, so you would need 2 pieces.

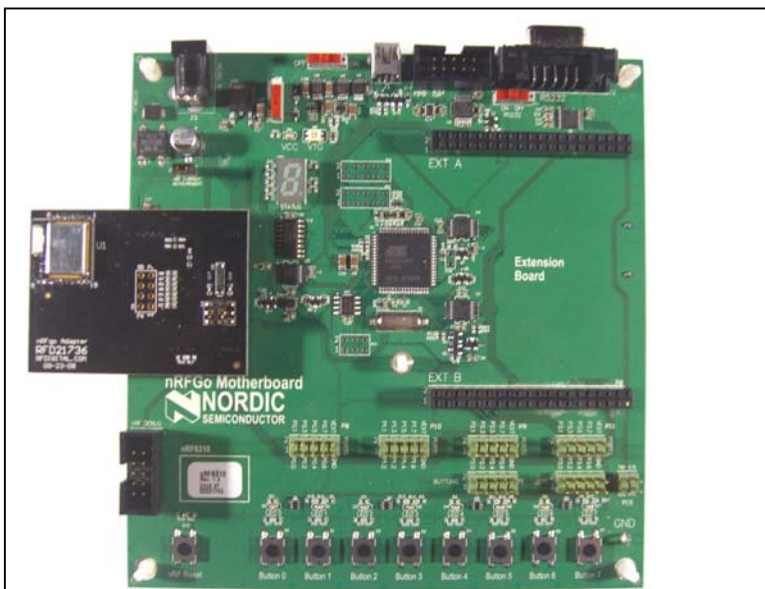

Nordic nRFGo Starter Kit Shown with RF Digital's RFD21736 module radio board plugged onto it.

Option 1:
Nordic's nRF6700
Nordic's nRF24LE1-F16Q24-DK

Option 2:
Nordic's nRF6700
RF Digital's RFD21736 (2 pieces)

Option 3:
Nordic's nRF6700
Nordic's nRF24LE1-F16Q24-DK
RF Digital's RFD21736 (1 piece)

Option 4:
Don't do any development at all, and just buy the **READY-TO-USE, RFD21733, RFD21735, RFD21737**, line of modules and eval boards which includes RF Digital's RFDP8 application protocol, that provides built-in functions for **LOGIC SWITCH INPUTS / OUTPUTS, Serial UART at 9600-8N1 RFID, Unique Electronic Serial Number, PAIRING, and NETWORKING** which allows you to be up and running in minutes!

Patents Pending

13715 Alton Pkwy • Irvine • CA • 92618

Tel: 949.610.0008 • Fax: 949.610.0009

www.rfdigital.com • sales@rfdigital.com

RoHS

In System Programming (ISP) using the nRFgo

The RFD21731, RFD21732, RFD21734 all have the nRF24LE1 radio IC inside with a built-in 8051 controller. To program (load your own code) into the nRF24LE1 you use the nRF6310 development board along with the nRFgo Studio software which is included in the nRF6700 nRFgo Starter Kit pictured above. The nRF6310 does not have an nRF24LE1 on it anywhere, you have two options with how to connect an nRF24LE1 to the nRF6310 development board. One option is that you can plug a Nordic development kit module (nRF24LE1-F16Q24-DK or RFD21736) into P3 and P4 on the nRF6310 development board. The second option is that you can use the ISP (In System Programming) connector (P16) located on the nRF6310. You must not use both, just use one or the other. In this section we will only be speaking about using the ISP only to program an RFD21731, RFD21732 or RFD21734 located on your own PCB using a cable from the nRF6310 development board P16 ISP port.

Location and pinout of P16 ISP Programming Connector.

P16 - PINOUT - TOP VIEW

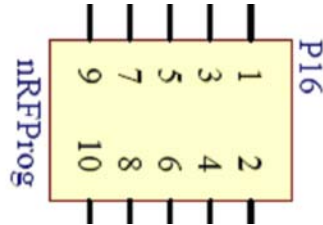

Pin 1 of P16
ISP Programming Connector
on nRF6310 (nRFgo).

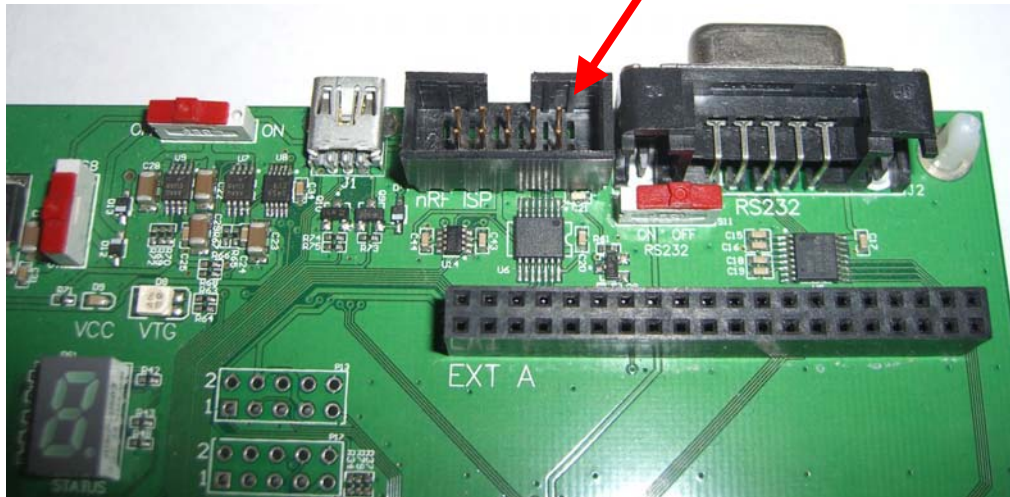

Patents Pending

13715 Alton Pkwy • Irvine • CA • 92618

Tel: 949.610.0008 • Fax: 949.610.0009

www.rfdigital.com • sales@rfdigital.com

RoHS

Schematic - P16 section from nRF6310 development board

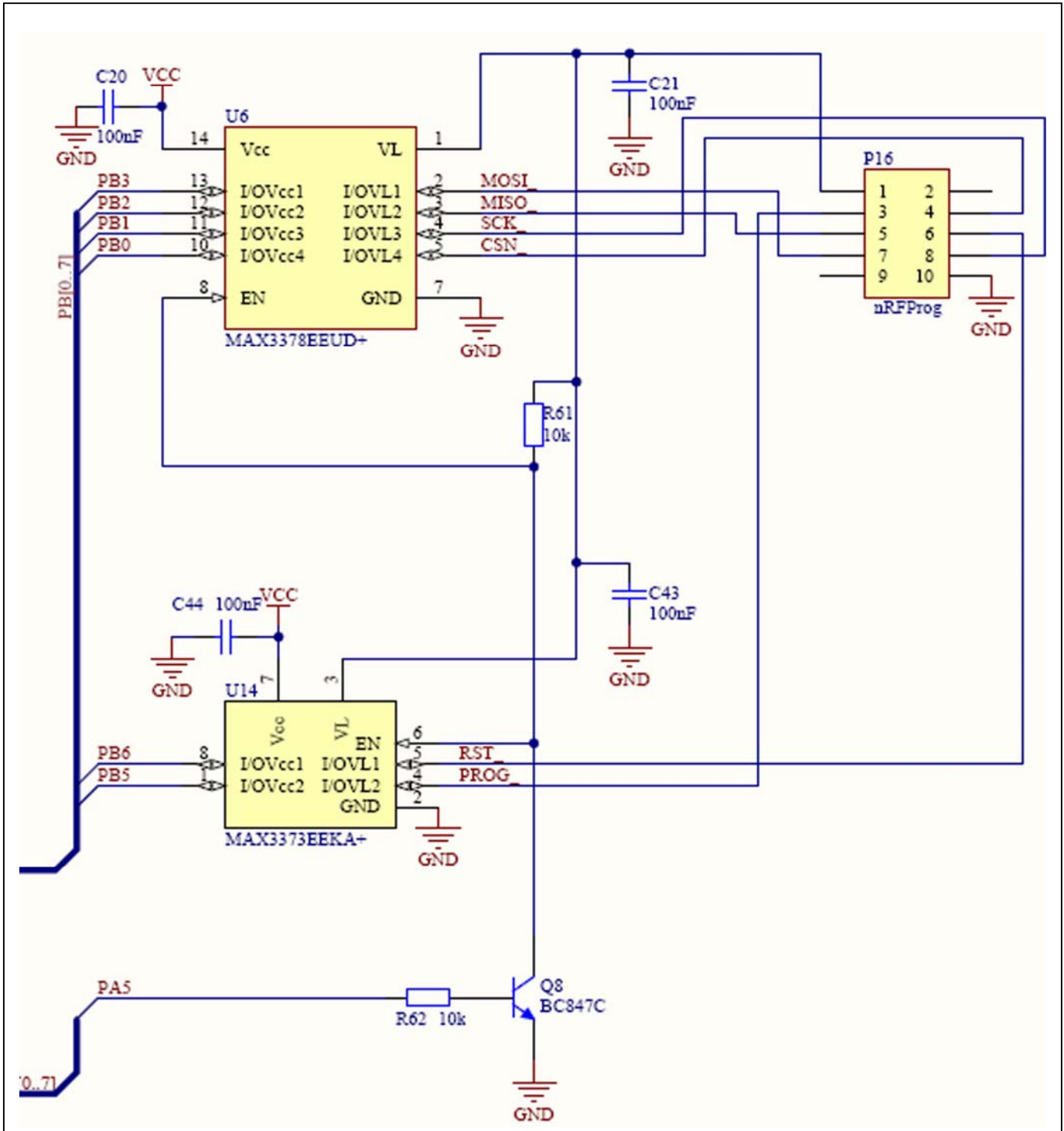

Patents Pending

13715 Alton Pkwy • Irvine • CA • 92618

Tel: 949.610.0008 • Fax: 949.610.0009

www.rfdigital.com • sales@rfdigital.com

RoHS

nRF24LE1-Q24 Pin Assignments

Blow is a copy from the Nordic nRF24LE1 data sheet version 1.4. Please refer to the Nordic data sheet for full details. This is only provided as a quick reference and not the information you should use for development.

Pin	Default connections		Dynamically enabled connections											
	Inputs ^a	Outputs ^a	XOSC32K	SPI Master	Slave/Flash SPI		HW Debug		2-Wire		PWM		ADC/COMP	
			priority 1	priority 2	priority 3		priority 4		priority 5		priority 6		priority 7	
P0.6	p0Di.6 UART/ RXD	p0Do.6					OCITO	out	W2SDA	inout	PWM1	out	AIN6	ana
P0.5	p0Di.5	p0Do.5 UART/ TXD			SCSN	in	OCITDO	out	W2SCL	inout			AIN5	ana
					FCSN ^b	in								
P0.4	p0Di.4 T0	p0Do.4		MMISO	in	SMISO	out	OCITDI	in				AIN4	ana
						FMISO ^a	out							
P0.3	p0Di.3	p0Do.3		MMOSI	out	SMOSI	in	OCITMS	in		PWM0	out	AIN3	ana
						FMOSI ^a	in							
P0.2	p0Di.2 GPINT1	p0Do.2		MSCK	out	SSCK	in	OCITCK	in				AIN2	ana
						FSCK ^a	in							
P0.1	p0Di.1	p0Do.1	CLKLFC ^c										AIN1	ana
P0.0	p0Di.0 GPINT0	p0Do.0	CLKLFD ^d	ana									AIN0	ana
Conflict exists, use priorities to determine IO allocation														
Conflict may exist depending on device configuration. In the case of a conflict, use priorities to determine IO allocation														

nRF24LE1-Q24 to nRFgo P16 MISO MOSI Interface Explanation

Nordics nRFgo programming board uses an on-board AT90USB1287/16AU microcontroller to program the nRF24LE1-Q24 through a master-slave SPI communication using the MISO and MOSI lines on the AT90USB1287/16AU and the nRF24LE1-Q24. There are a set of pins required to perform the programming function and those pins are (in addition to power and ground): RST, PROG, SCN, SCK, MISO, MOSI. The RST, PROG, SCN and SCK signals are obvious they are outputs from the nRFgo programmer and inputs on the end of the nRF24LE1 module. However there are some easy mistakes that can be made with MISO and MOSI, so this is to explain detail about these two signals.

The nRF24LE1-Q24 Pin Assignments image (above) shows P0.2, P0.3, P0.4, P0.5 which are SCK, MOSIM MISO, CSN respectfully.

When the PROG pin is set to HIGH, those signals are called FSCN, FMISO, FMOSI, FSCK. They all have an "F" in front of them to indicate FLASH mode, which is only true when PROG line is high and SPI FLASH mode is entered.

This means that on the nRF24LE1-Q24 FMISO which is P0.4 is an OUTPUT and FMOSI which is P0.3 is an INPUT.

Continued on the next page...

Patents Pending

13715 Alton Pkwy • Irvine • CA • 92618

Tel: 949.610.0008 • Fax: 949.610.0009

www.rfdigital.com • sales@rfdigital.com

RoHS

The AT90USB1287/16AU schematic for PB [0..7] shown below, PB2 on the AT90USB1287/16AU is an MOSI signal Master Out, so it is an output since this chip is the master. The PB2 output signal goes into the left side of U6, into pin 12 and out pin 3 and then connects to pin 5 on P16, which then connects to P0.3 FMOSI on the nRF24LE1 which is pin 4 on the RFD21731,2,4 and pin 8 on the RFD21741.

The AT90USB1287/16AU schematic for PB [0..7] shown below, PB3 on the AT90USB1287/16AU is an MISO signal Master In, so it is an input since this chip is the master. The PB3 input signal goes into the left side of U6, into pin 13 and out pin 2 and then connects to pin 7 on P16, which then connects to P0.4 FMISO on the nRF24LE1 which is pin 5 on the RFD21731,2,4 and pin 9 on the RFD21741.

The AT90USB1287/16AU is the master and the nRF24LE1 is the slave.

AT90USB1287/16AU

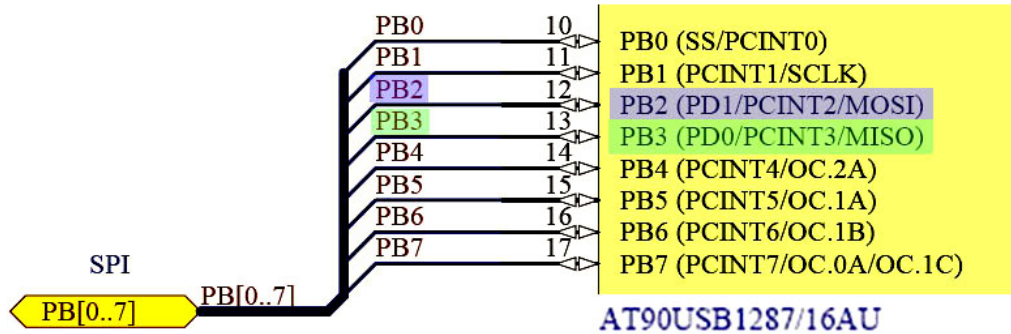

U6 and P16

IGNORE THESE TWO MOSI AND MISO SIGNAL LABELS

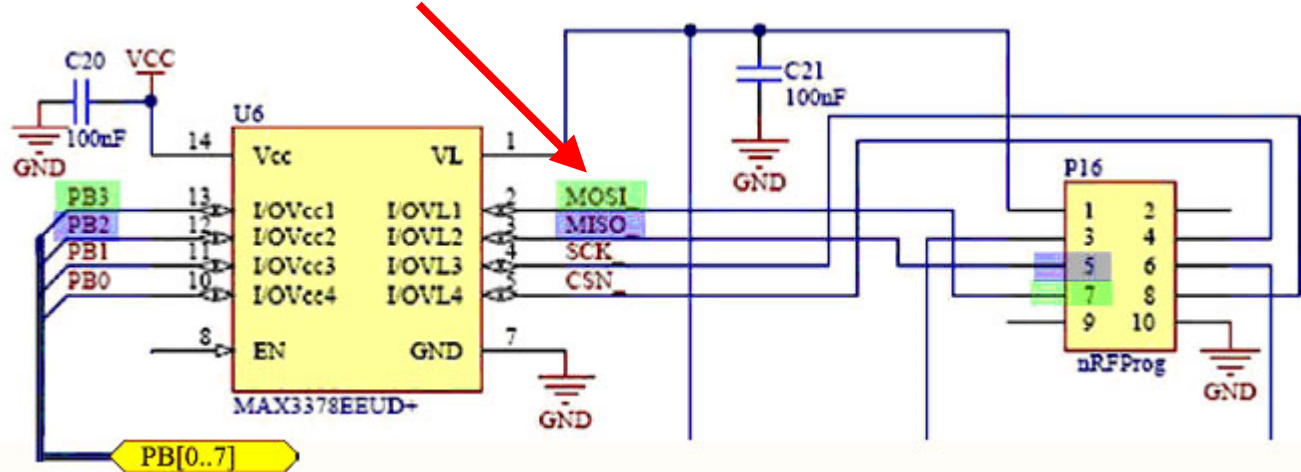

Patents Pending

13715 Alton Pkwy • Irvine • CA • 92618

Tel: 949.610.0008 • Fax: 949.610.0009

RoHS

www.rfdigital.com • sales@rfdigital.com

ETSI • CE Compliant

P16 programming connector wiring to external RF Module

The Nordic nRFgo board does not supply power to P16. You must supply your own power to pin 13 of module AND pin 1 of P16 on the nRF6310 board, because pin 1 of P16 sets the logic level voltage of P16, it must be the same voltage as the module supply. 1.9V minimum to 3.6V maximum, typically 3.0 or 3.3V.

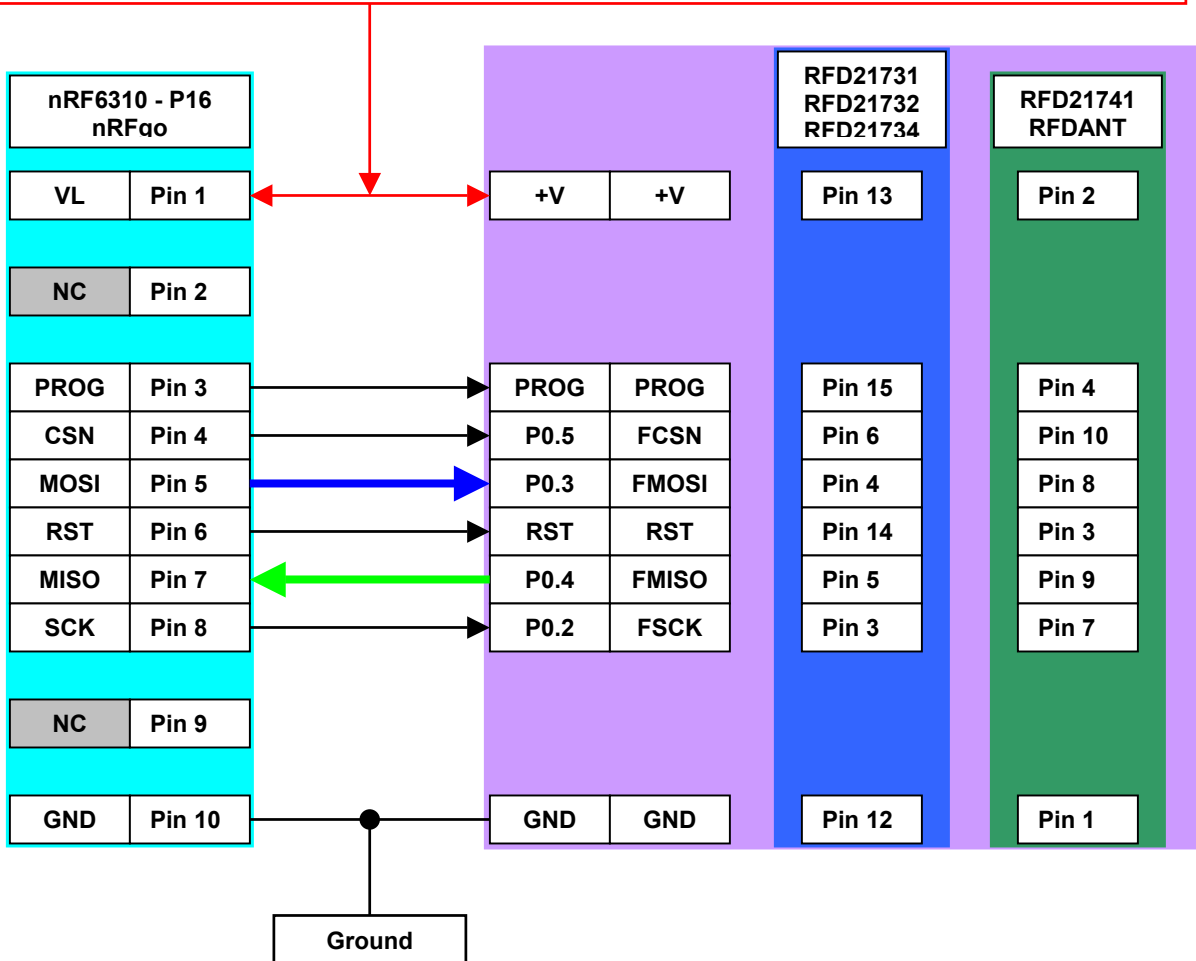

IMPORTANT

Pins 3, 4, 5 and 6 of the RFD21731, RFD21732, RFD21734 are used by the ISP for high speed communication when loading code (programming) the nRF24LE1. The MAX3373 and MAX3378 level shifter ICs used in the development to talk to these four lines must not be loaded too much, as if they are it will prevent programming of the nRF24LE1 inside of the module. So we have found that the minimum allowable value is a maximum resistive load to sink or source on any of the four pins is 47K ohms. 100K or larger is better. If you are programming module with pins 3, 4, 5 or 6 of the module not being tied to any point in your circuit other then to the P16 programming connector, then no need to worry about the loading. However if you are doing true in system programming where you are also using the four pins, then you must design your circuit in a way that when programming your circuit connections to any of those four pins do not cause any loader lower then 47k, as that will distort the high speed programming signals and prevent programming. If you encounter any programming problems using ISP, then look at all 6 programming signals and verify they look clean and do not have overshoot, ringing, distortion and have proper logic levels.

Patents Pending

13715 Alton Pkwy • Irvine • CA • 92618

Tel: 949.610.0008 • Fax: 949.610.0009

www.rfdigital.com • sales@rfdigital.com

ETSI • CE Compliant

RoHS

Overall Dimensions • Top View

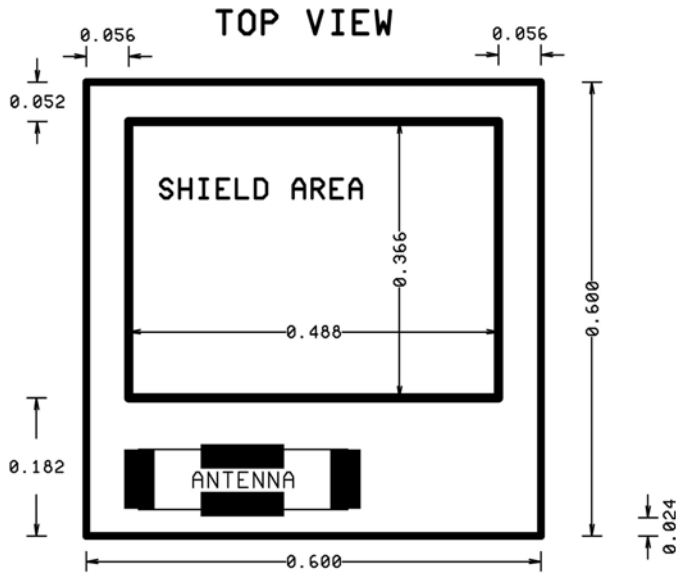

Overall Dimensions • Side View

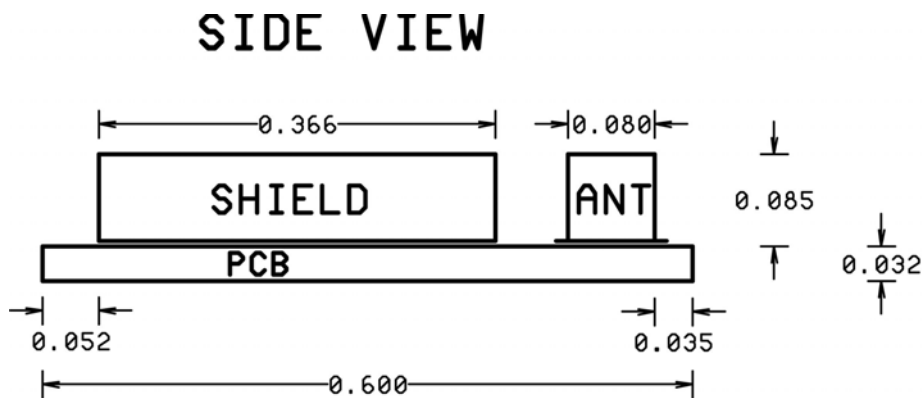

Patents Pending

13715 Alton Pkwy • Irvine • CA • 92618

Tel: 949.610.0008 • Fax: 949.610.0009

www.rfdigital.com • sales@rfdigital.com

RoHS

PCB Layout

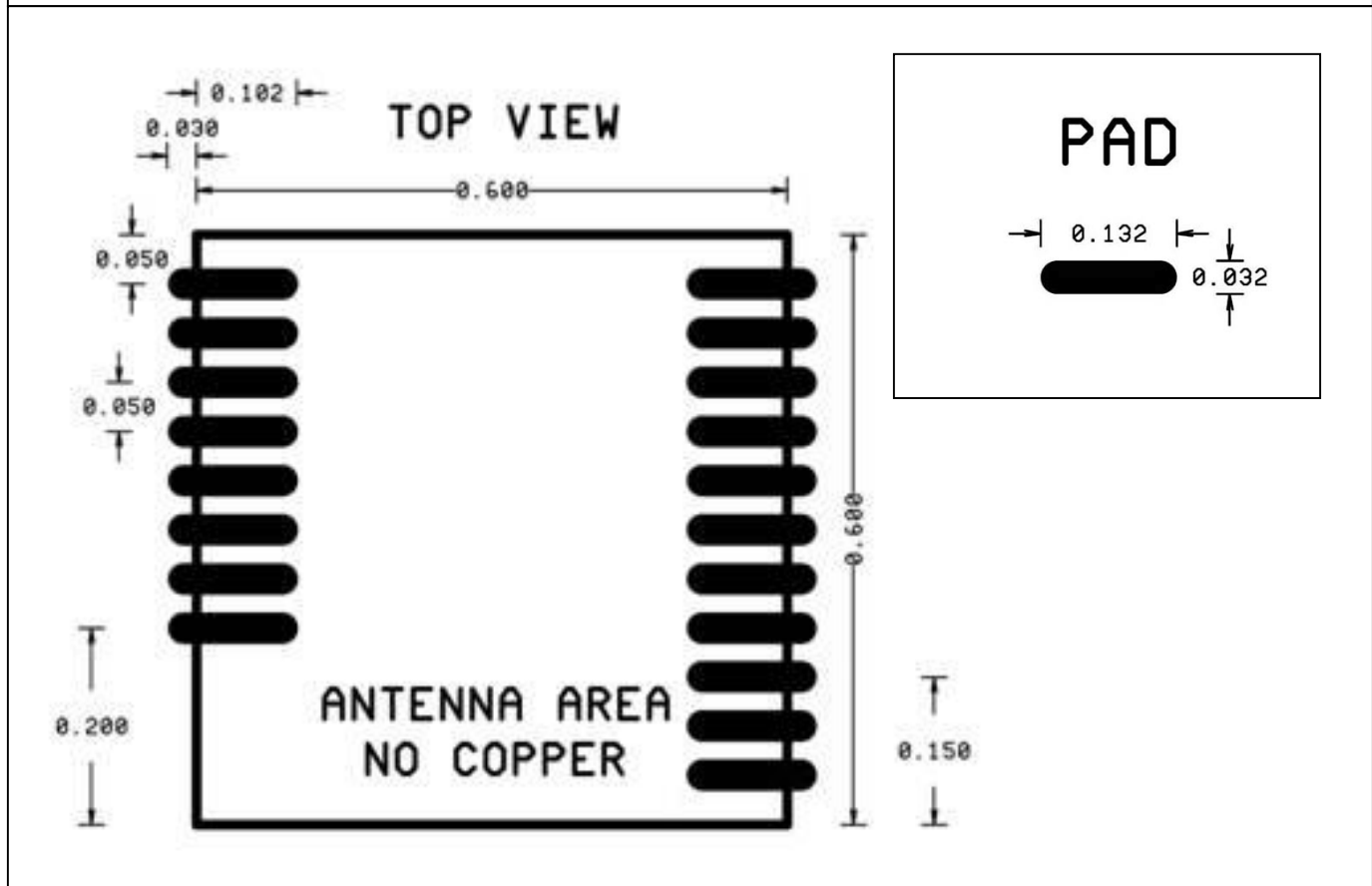

Patents Pending

13715 Alton Pkwy • Irvine • CA • 92618

Tel: 949.610.0008 • Fax: 949.610.0009

www.rfdigital.com • sales@rfdigital.com

ETSI • CE Compliant

RoHS

RoHS
Declaration Of Conformity
July 26, 2009

RF Digital declares that part numbers

- RFD21731
- RFD21732
- RFD21733
- RFD21734
- RFD21735
- RFD21736
- RFD21737
- RFD21738
- RFD21739
- RFD21740
- RFD21741
- RFD21742
- RFD21743
- RFD21764

are manufactured with RoHS materials.

Patents Pending

13715 Alton Pkwy • Irvine • CA • 92618

Tel: 949.610.0008 • Fax: 949.610.0009

www.rfdigital.com • sales@rfdigital.com

ETSI • CE Compliant

RoHS

DECLARATION OF CONFORMITY

July 26, 2009

RF Digital declares that part numbers

- RFD21731
- RFD21732
- RFD21733
- RFD21734
- RFD21735
- RFD21741
- RFD21742
- RFD21743

comply with ETSI EN 300 440-2 power requirements

as called out in the R&TTE V1.2.1 Directive

Technical documents for the above mentioned part numbers are held at
RF Digital Corporation
13715 Alton Pkwy.
Irvine, CA 92618

Patents Pending

13715 Alton Pkwy • Irvine • CA • 92618

Tel: 949.610.0008 • Fax: 949.610.0009

www.rfdigital.com • sales@rfdigital.com

ETSI • CE Compliant

RoHS

Washing

The RFD21731, RFD21732 and RFD21734 are NOT washable.

Use no-clean flux, leaded or lead-free. If you attempt to wash the modules, water will enter beneath (inside) the RF shield and get trapped, which may cause device failure or damage once powered on. There is no way to make sure all water has been removed before powering the module so do NOT wash the modules.

Potting, Encapsulation and Conformal Coating

Do NOT pot or conformal coat the RFD21731, RFD21732 and RFD21734.

If you plan on encapsulating the RFD21731, RFD21732 or RFD21734 in a potting compound or conformal coating, you must assure that the compound in liquid or solid form does not enter under the shield where there are sensitive RF components. Some of the capacitive values are as low as half a picofarad and sensitive to contacting materials such as potting compounds. There are potting compounds and conformal coatings which have very good dielectric constants and are suitable for 2.4 GHz potting applications, however, when you apply any of these, they were accounted for in the circuit design and might reduce performance of the device or all together cause it not to function.

Applying any compound, conformal coating or potting directly to the module voids any and all warranty and support service.

If your application requires 100% sealing of the module, there is a way to do this very successfully without impacting the module performance. Simply place the module on your PCB. Place a plastic cover over the module (like a hat), make the cover large enough to cover the whole module. Apply glue around the bottom perimeter of the cover where it sits on the PCB. This allows the module to function in free airspace while there is a complete seal around it. This information is only for reference and you should do your own testing with your application to find the best suitable fit for your own design.

Reflow Profile

Use standard lead-free or leaded reflow profile for the RFD21731, RFD21732 and RFD21734. Your CM (Contract Manufacturer) should profile this module along with your PCB and all other parts on it through their reflow oven to properly set a profile suitable for all the parts on the board combined.

If you are building a double sided placement board, place this device last so it will not be attempted to be reflowed upside-down.

As with building any RF devices, you should always build a small quantity through your production process, test and verify, then increase your quantities to make sure the process is not harmful to the performance of your RF system. This is true with any RF system, including use of these modules.

Patents Pending

13715 Alton Pkwy • Irvine • CA • 92618

Tel: 949.610.0008 • Fax: 949.610.0009

www.rfdigital.com • sales@rfdigital.com

RoHS

RFD21731 / RFD21732 / RFD21734 Tray Packaging

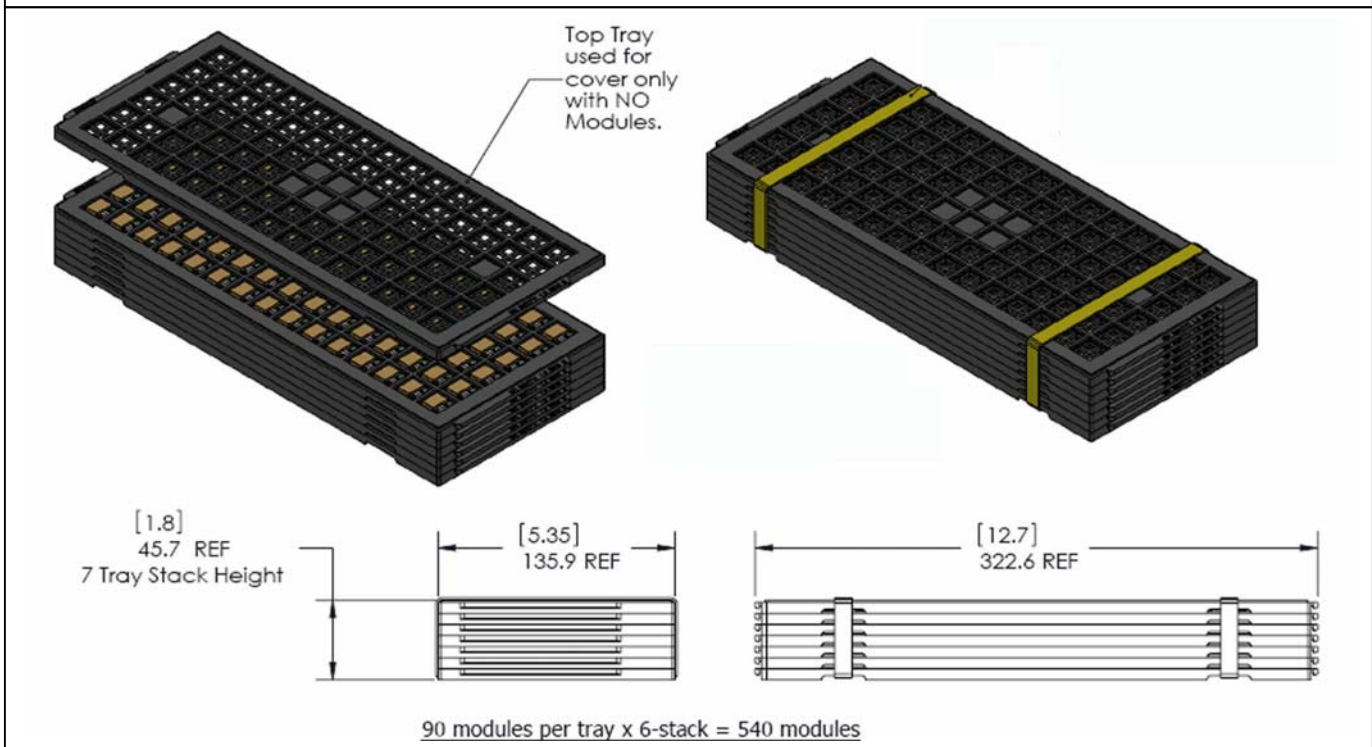
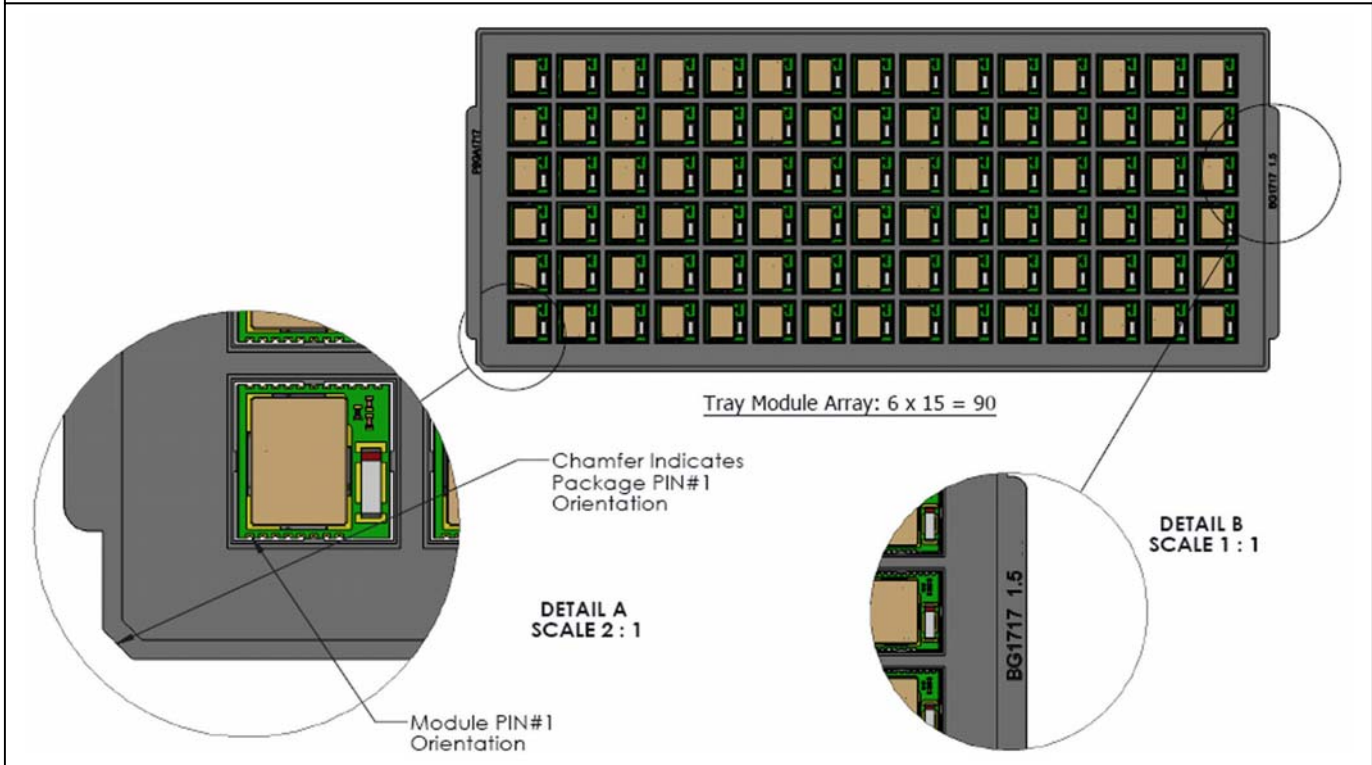

Patents Pending

13715 Alton Pkwy • Irvine • CA • 92618

Tel: 949.610.0008 • Fax: 949.610.0009

www.rfdigital.com • sales@rfdigital.com

ETSI • CE Compliant

RoHS

RFD21731 / RFD21732 / RFD21734 Tray Packaging

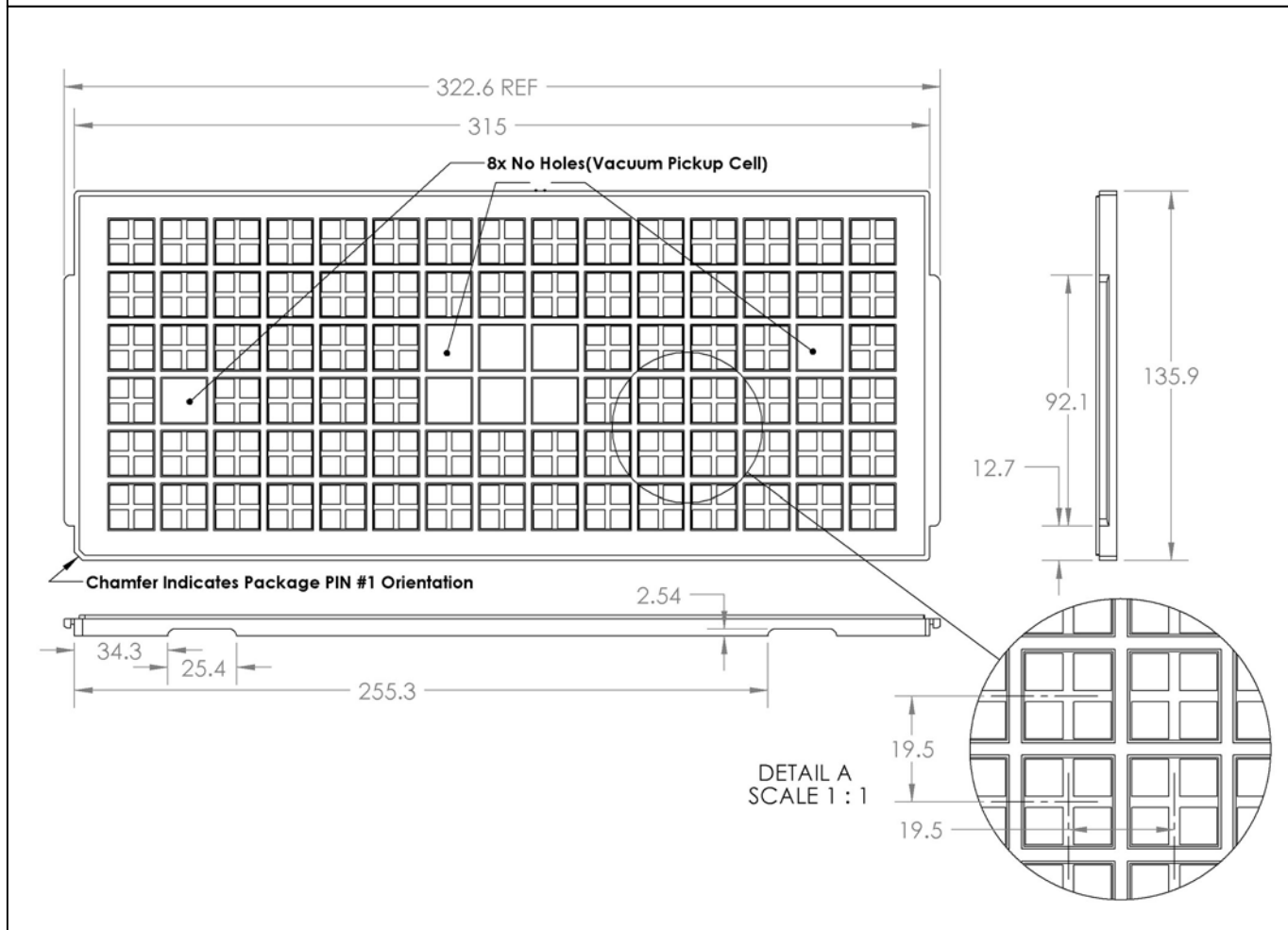

Patents Pending

13715 Alton Pkwy • Irvine • CA • 92618

Tel: 949.610.0008 • Fax: 949.610.0009

www.rfdigital.com • sales@rfdigital.com

ETSI • CE Compliant

RoHS

RFD21731 / RFD21732 / RFD21734 Tray Packaging

7 Trays total, including 1 blank top tray

90 modules per tray x 6-stack = 540 modules

Top Tray
used for
cover only
with NO
Modules.

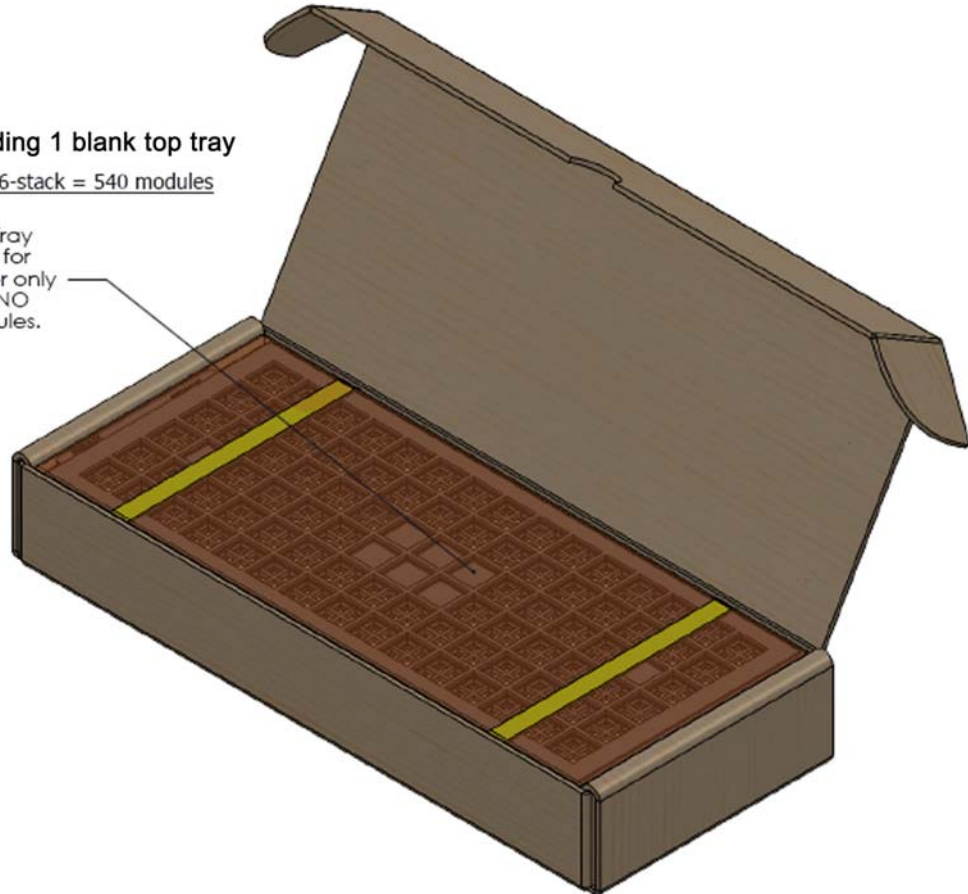

Important Notice

RF Digital reserves the right to make corrections, modifications, and/or improvements to the product and/or its specifications at any time without notice.

RF Digital assumes no liability for the user's product and/or applications.

RF Digital products are not authorized for use in safety-critical applications, including but not limited to life-support applications.

RF Digital assumes no liability for parts or their application beyond replacement or refunding the original purchase price.

All trademarks and trade names belong to their respective owners.

End of Document.

Patents Pending

13715 Alton Pkwy • Irvine • CA • 92618

Tel: 949.610.0008 • Fax: 949.610.0009

www.rfdigital.com • sales@rfdigital.com

RoHS

Nordic nRF6310 Development / Programming Board Schematic

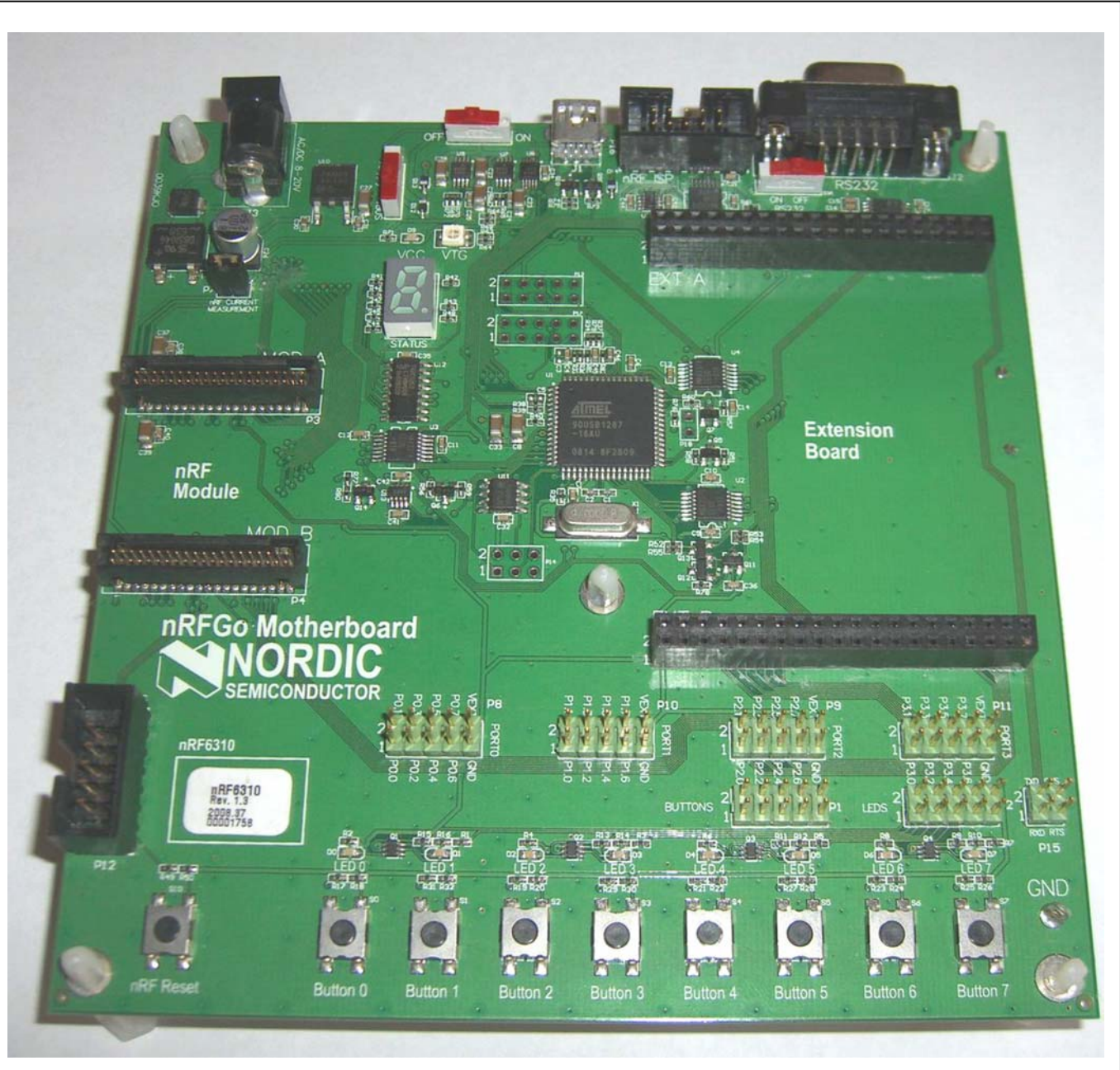

The following 5 pages of schematics are for the nRF6310 board above. Two of these boards are included with the Nordic nRF6700 kit. The nRF6700 kit is also referred to as the "nRFGo" kit. References made to the nRFGo board are referring to the nRF6310 board pictured above with it's schematic below.

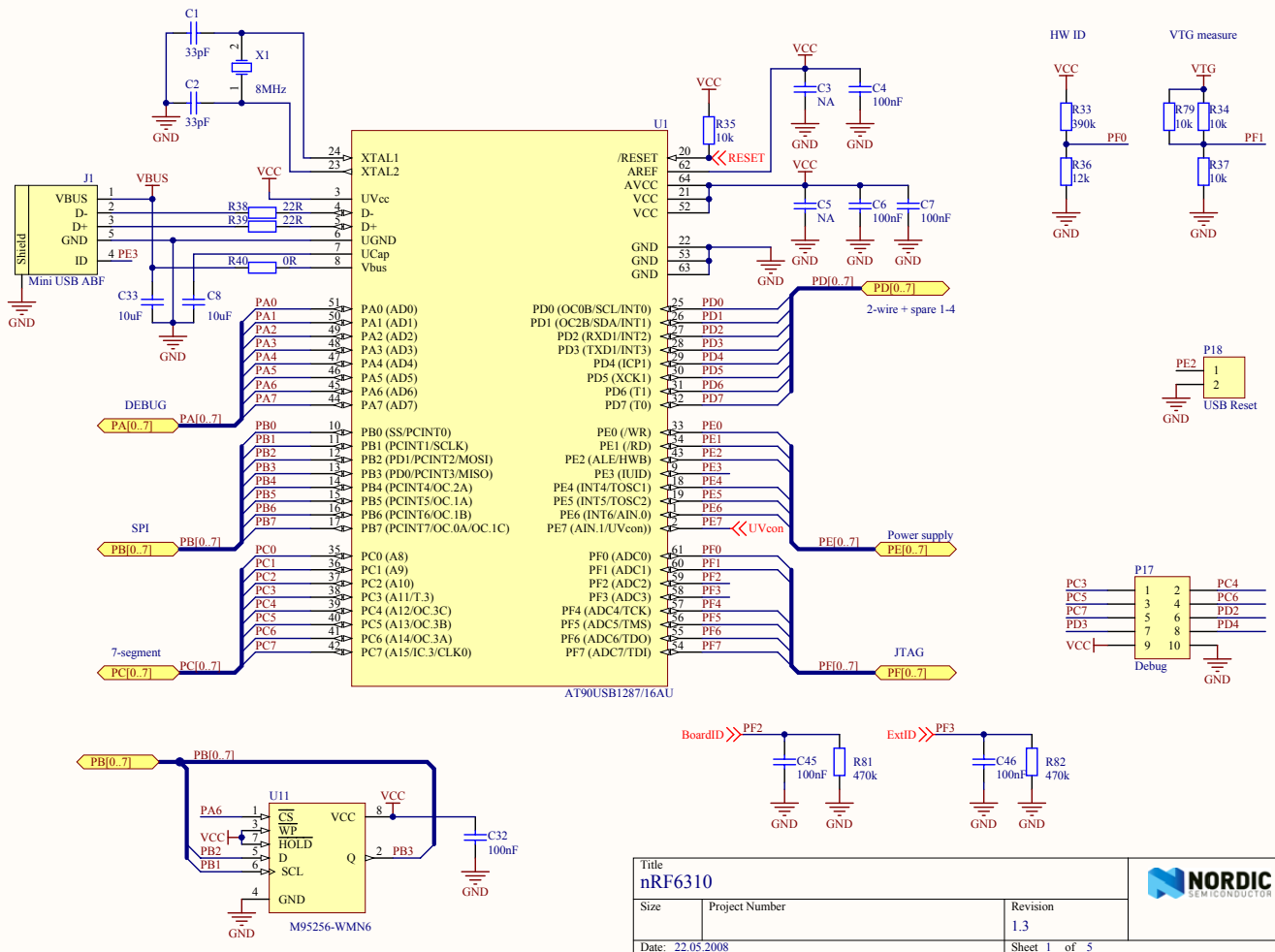

Title nRF6310			
Size	Project Number	Revision 1.3	
Date: 22.05.2008	File: Control MCU_Rev1.3.SchDoc		Sheet 1 of 5 Drawn By: KJO

Device ports

Expansion ports

Device ports

Expansion ports

Device ports

Expansion ports

Device ports

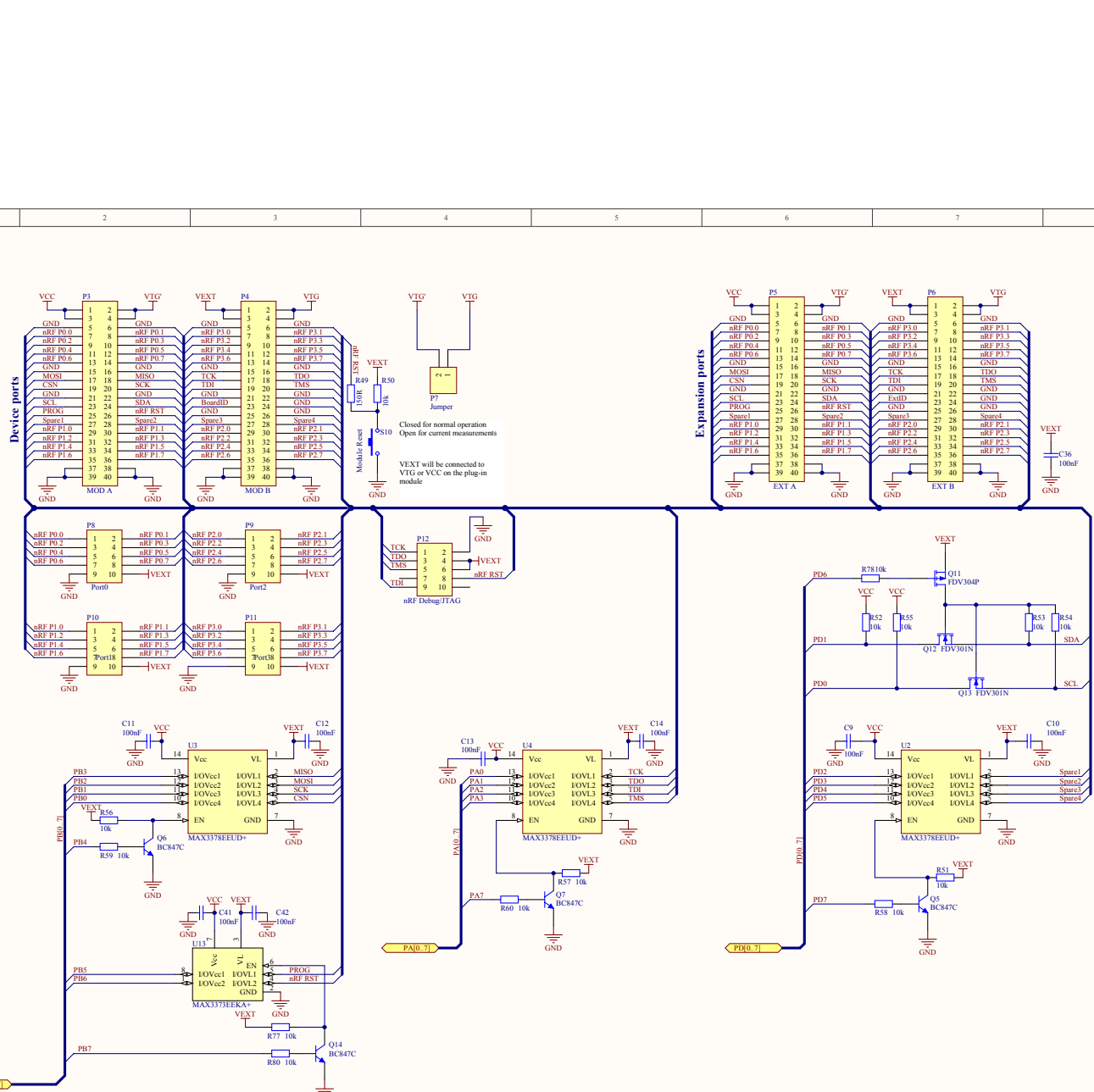

Title		nRF6310	
Size	Project Number	Revision	1.3
Date:	22.05.2008	Sheet 2 of 5	
File:	Extension_Rev1_3SchDoc	Drawn By:	KJO



1 2 3 4 5 6 7 8

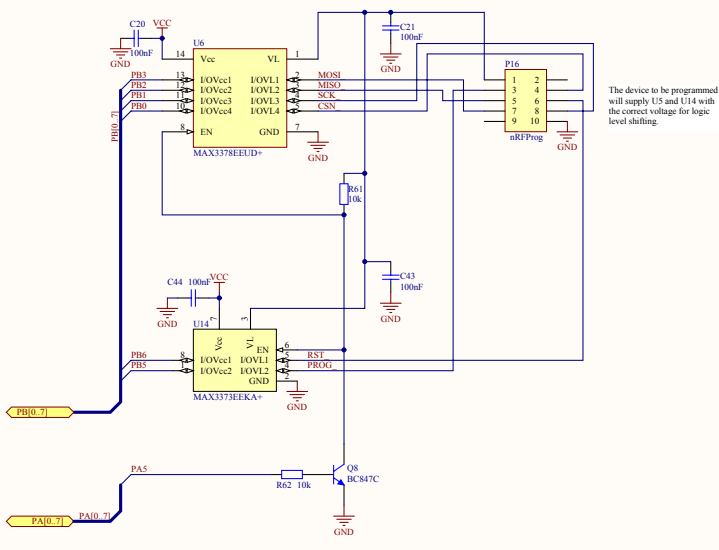
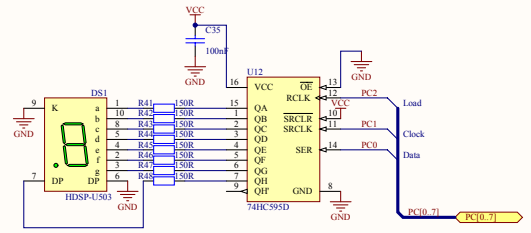
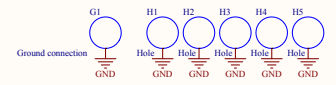
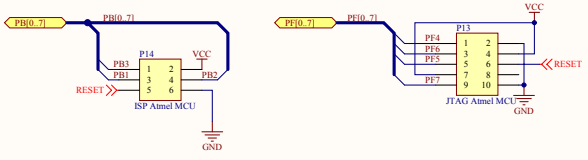

The device to be programmed will supply U5 and U14 with the correct voltage for logic level shifting.

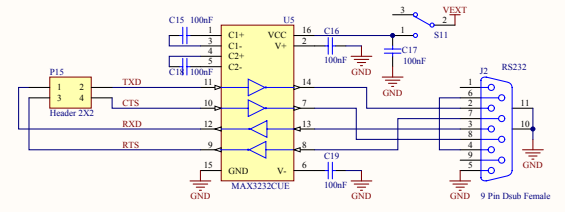

Title nRF6310		Revision 1.3		
Size	Project Number	Sheet 3 of 5		
Date: 22.05.2008	ProjectNumber	Drawn By: RJO		
File: Interfaces_Rev1.3_SchDoc				

1 2 3 4 5 6 7 8

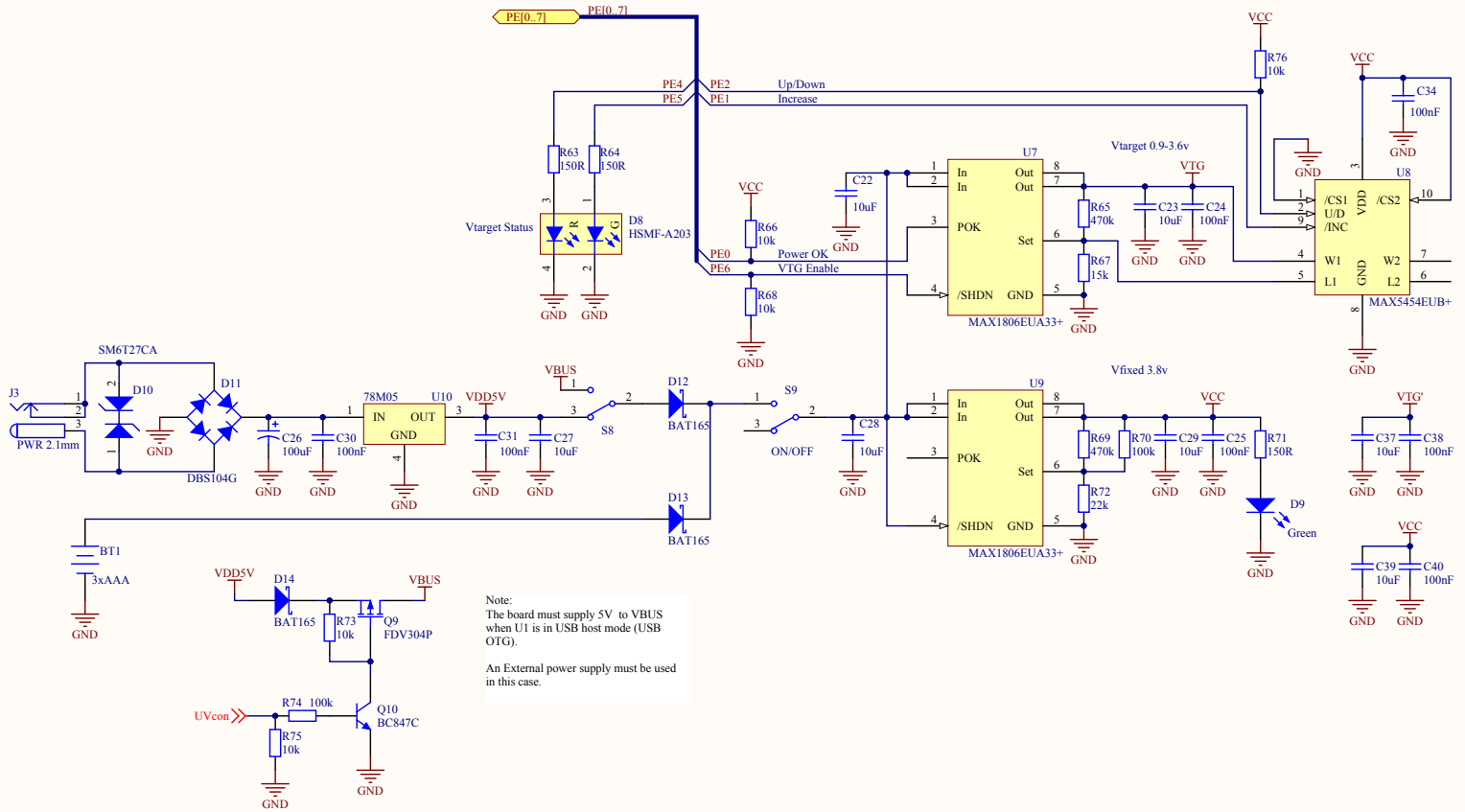

Title nRF6310		
Size	Project Number	
Date: 22.05.2008	Revision 1.3	Sheet 4 of 5 Drawn By: KJO
File: Power supply_Rev1_3.SchDoe		

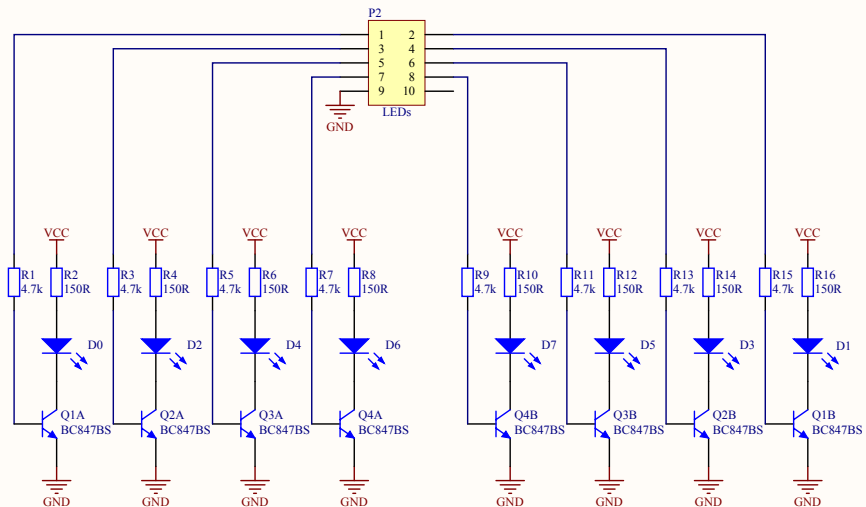
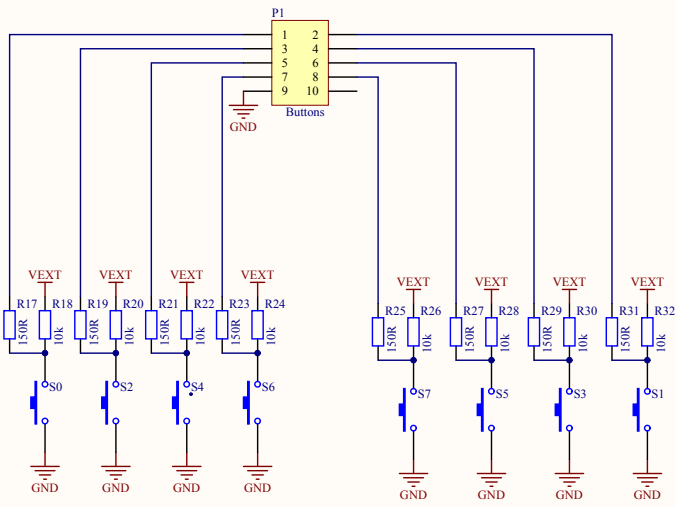

Title nRF6310		Revision 1.3	
Size	Project Number		
Date: 22.05.2008		Sheet 5 of 5	
File: Buttons LEDs_Rev1_3.SchDoc		Drawn By: KJO	

Surface Mounted RF Module Layout Examples

For Part Numbers RFD21731, RFD21732, RFD21733, RFD21734, RFD21735

Go to <http://www.rfdigital.com> for complete data sheet.

For free RF layout design reviews, send color screen captures of your layout to support@rfdigital.com, you will save time and money before you fabricate your boards.
We are always here to support you!



Legend

Please use the legend below to identify the colors, objects and their meanings in this document.



0.031 to 0.062 PCB



TOP COPPER



BOTTOM COPPER



NO COPPER or COMPONENTS



VIA BETWEEN TOP AND BOTTOM

RFD21731, RFD21732, RFD21733 Layout Example Pinout

This Layout Examples document only references pins that are common to all RFD21731,2,3,4,5 modules and matter to the layout, which are ground and external antenna connections where applicable. To keep the file size of this document small, some of the larger images are outputted in lower resolutions, for full details on pinouts refer to the data sheet for the appropriate part number, which can all be found at <http://www.rfdigital.com>.

Pins labels 3,4,5,6,7,14,15,16,17 change based on which part number module is being used, however that does not matter for this document, because the same layout rules apply to the RFD21731, RFD21732, RFD21733, RFD21734 and RFD21735 modules. Majority of this document addresses the RFD21731, RFD21732, RFD21733 and the end of this document addresses the RFD21734 and RFD21735.

If you have any questions, feel free to contact RF Digital Support anytime, we're always here to help you!

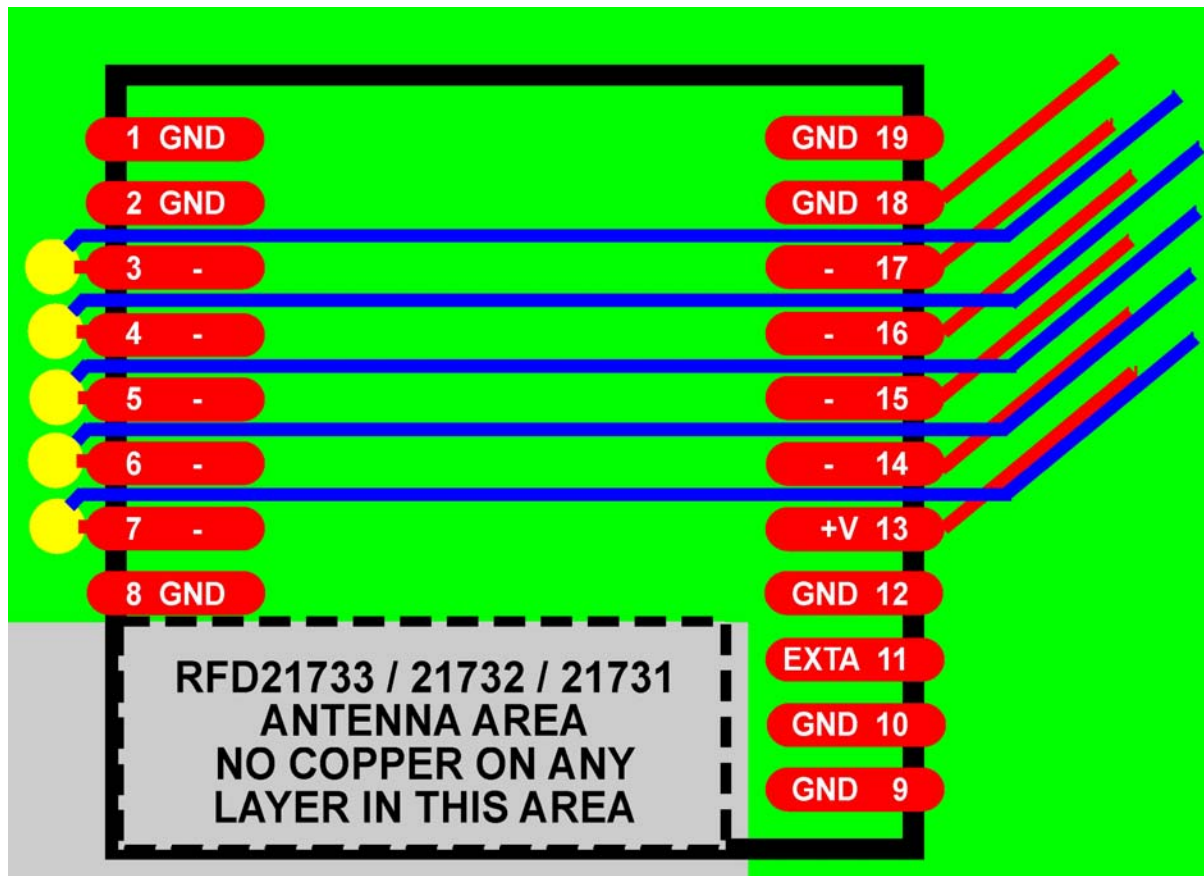

RFD21731, RFD21732, RFD21733 Layout Examples

The following layout examples are for the RFD21731, RFD21732 and RFD21733 module which all have a built-in chip antenna. Later in this document there are examples for the RFD21734 and RFD21735 modules, which are for use with external antennas.

RFD21731, RFD21732, RFD21733 Antenna Pattern

This is a typical antenna pattern, however does vary based on many factors including surrounding components and ground planes. It is only provided as a reference. The one inch copper plane shown helps maintain the balanced antenna pattern and when possible should be used, if not possible, its not required.

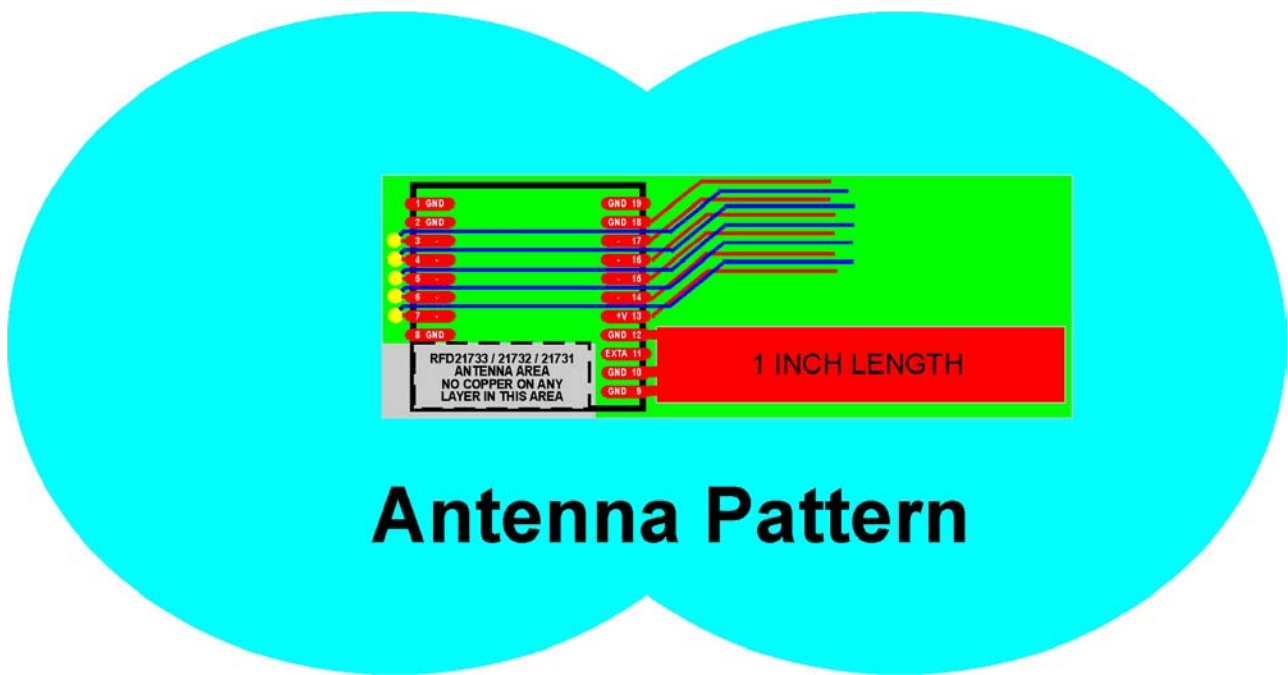

Antenna Pattern

RFDANT	RF Module
RFD21743	RFD21731
RFD21741	RFD21732
	RFD21733
	RFD21734
	RFD21735

RFD21731, RFD21732, RFD21733 Keep Out Area - Example 1

When placing the module into a plastic enclosure, it is highly recommended that you locate the module in the corner of the enclosure / PCB so it will be as far away from your other components on the PCB and as close to free airspace as possible. In addition, you want to locate the module in a position in your product where it will have as much free airspace as possible near the antenna when in use. For example if it will be placed against a wall, it is preferred to locate the module so it will be in a location in your product where it will be on the side of the product where it will be further away from the wall, rather than directly next to it, so the RF signal can have as much free airspace to give you the best range performance possible. (Note: If you plan on using a metal enclosure, you can not locate the module inside of the enclosure or it will have very limited range, for metal enclosures we recommend the RFD21743 which is specifically suited for that.) The electrical ground connection to the module is to be made with a thin trace so the one inch ground plane off to the side can be effective.

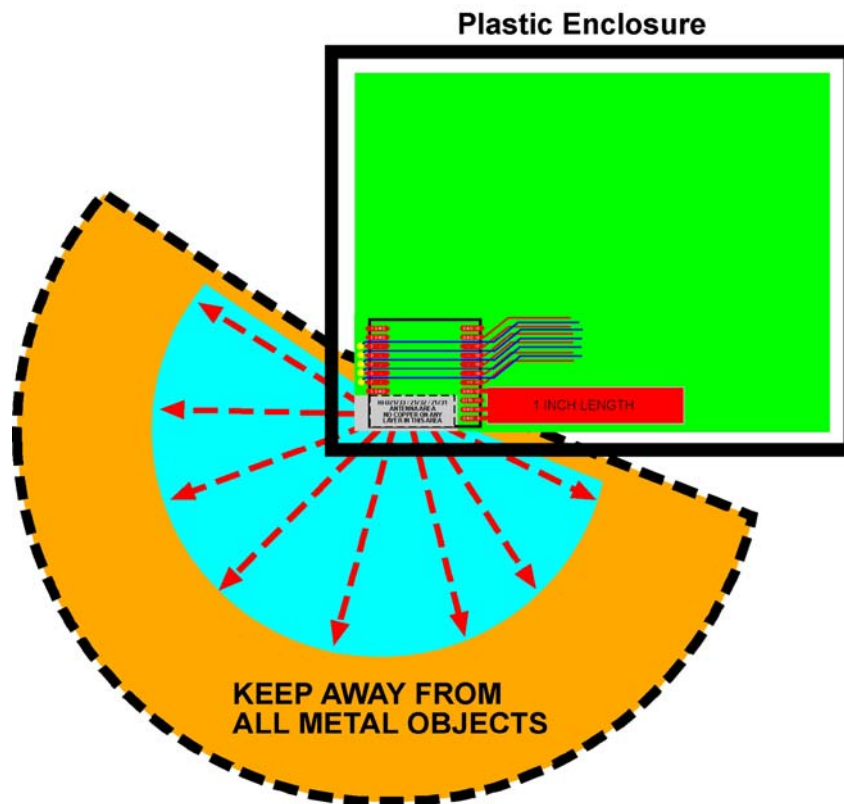

RF Signals in this area.

If you place anything such as components, wires, metal parts of any type in this area, it will block the RF signals and drastically limit your range. Leave this area open.

RFD21731, RFD21732, RFD21733 - Layout Examples 2

The gray area shows where to keep free from copper and components. The one-inch length copper area is optional, however does improve the range if you can add it. Parts can be placed all over the rest of the board, however if possible keep about a half-inch distance from the one inch length ground area to the right of the module, again, only if possible. Also the signal connections to the module can be made on either layer. The electrical ground connection to the module is to be made with a thin trace so the one inch ground plane off to the side can be effective.

Plastic Enclosure

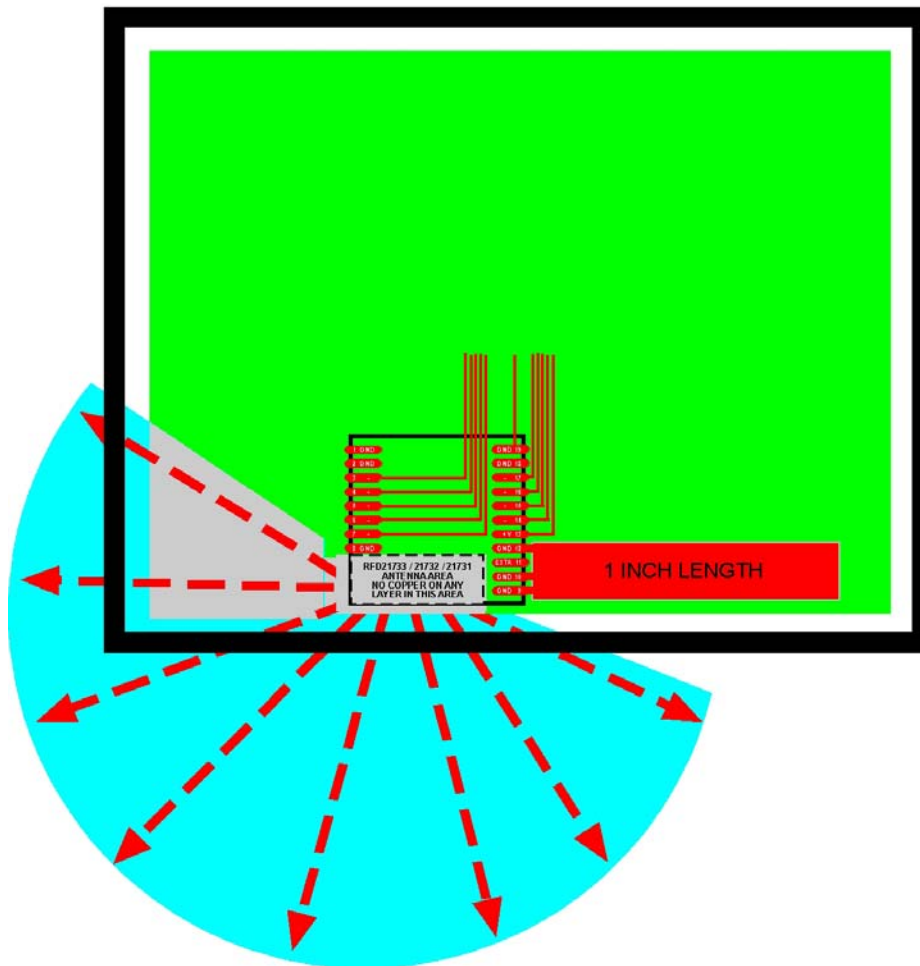

RF Signals in this area.

If you place anything such as components, wires, metal parts of any type in this area, it will block the RF signals and drastically limit your range. Leave this area open.

RFDANT	RF Module
RFD21743	RFD21731
RFD21741	RFD21732
	RFD21733
	RFD21734
	RFD21735

RFD21731, RFD21732, RFD21733 - Layout Examples 3

The gray area shows where to keep free from copper and components. The one-inch length copper area is optional, however does improve the range if you can add it. Parts can be placed all over the rest of the board, however if possible keep about a half-inch distance from the one inch length ground area to the right of the module, again, only if possible.

Plastic Enclosure

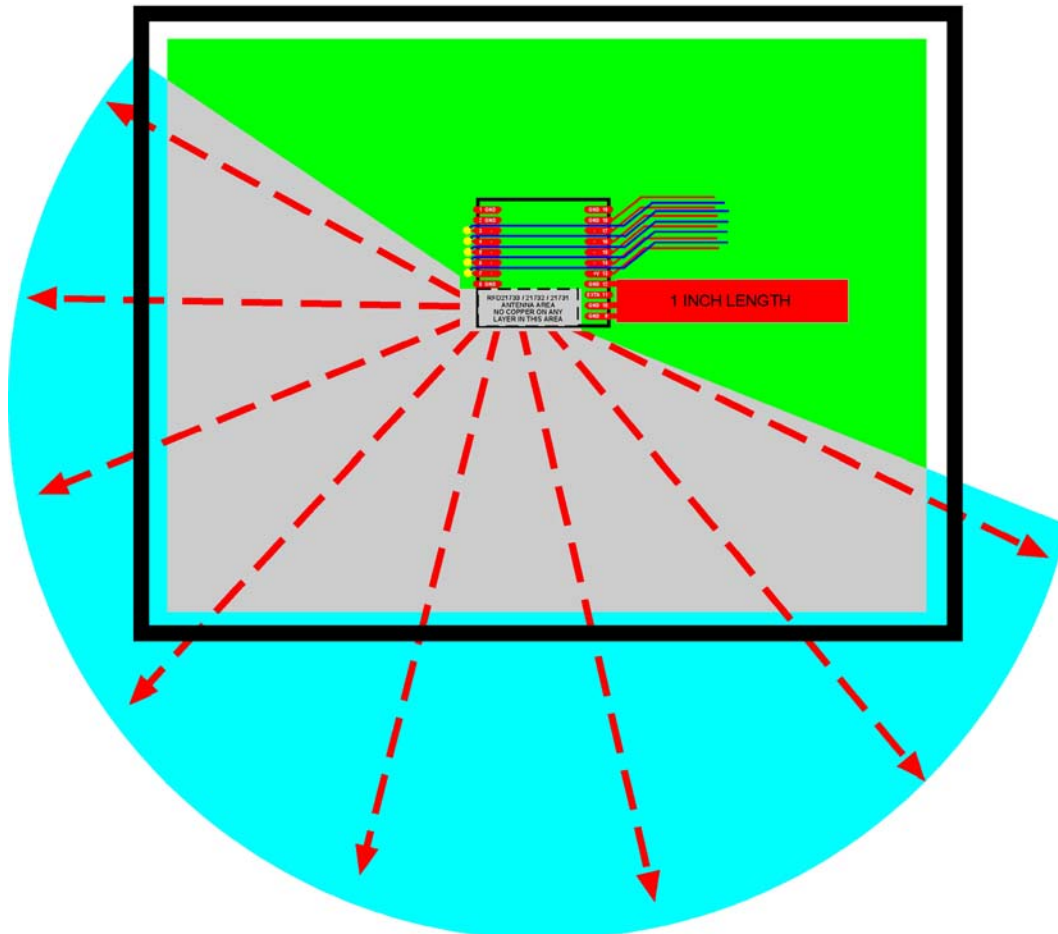

RF Signals in this area.

If you place anything such as components, wires, metal parts of any type in this area, it will block the RF signals and drastically limit your range. Leave this area open.

RFD21731, RFD21732, RFD21733 - Layout Examples 4

The gray area shows where to keep free from copper and components. The one-inch length copper area is optional, however does improve the range if you can add it. Parts can be placed all over the rest of the board, however if possible keep about a half-inch distance from the one inch length ground area to the right of the module, again, only if possible.

Plastic Enclosure

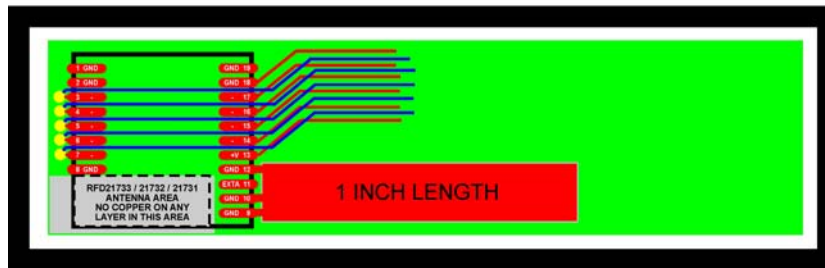

Plastic Enclosure

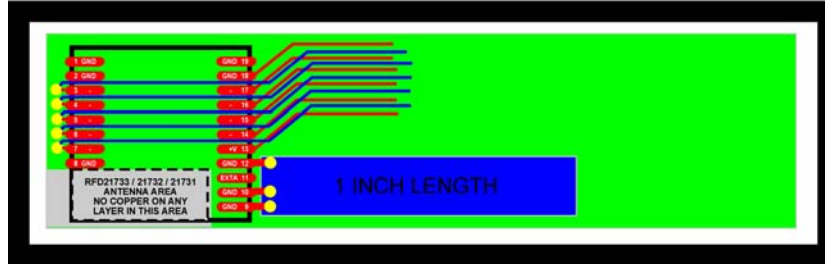

Plastic Enclosure

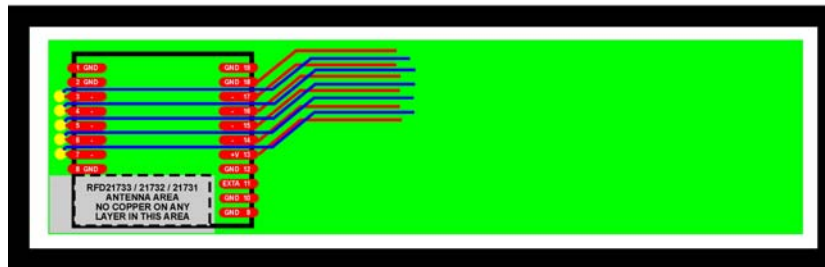

RFD21731, RFD21732, RFD21733 - Layout Examples 5

The gray area shows where to keep free from copper and components. The one-inch length copper area is optional, however does improve the range if you can add it. Parts can be placed all over the rest of the board, however if possible keep about a half-inch distance from the one inch length ground area to the right of the module, again, only if possible.

Plastic Enclosure

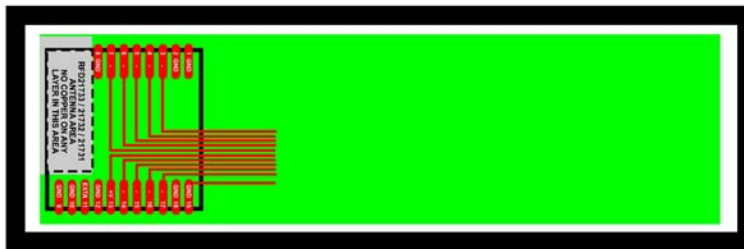

Plastic Enclosure

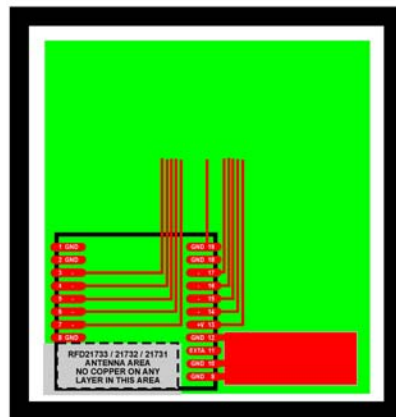

Plastic Enclosure

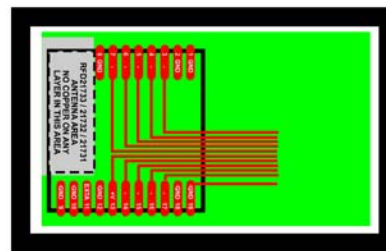

Plastic Enclosure

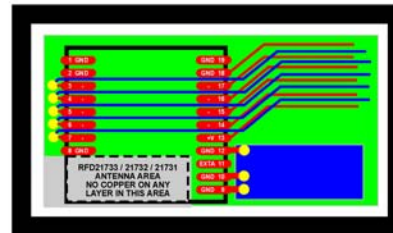

Plastic Enclosure

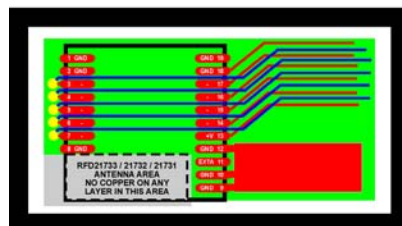

RFD21731, RFD21732, RFD21733 - Layout Examples 6

The gray area shows where to keep free from copper and components. The one-inch length copper area is optional, however does improve the range if you can add it. Parts can be placed all over the rest of the board, however if possible keep about a half-inch distance from the one inch length ground area to the right of the module, again, only if possible.

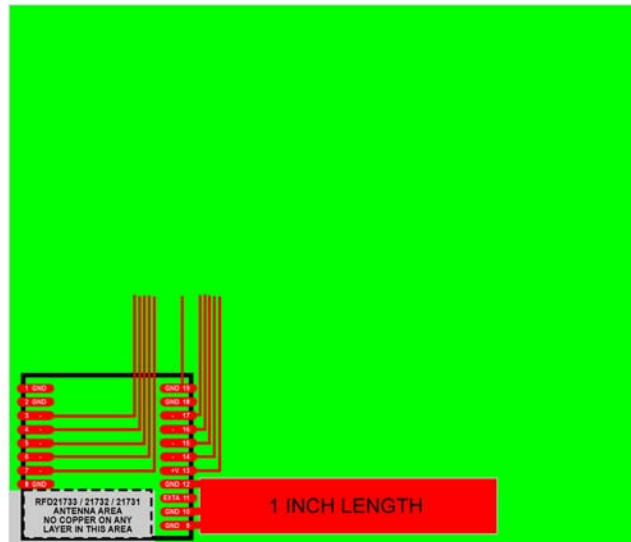
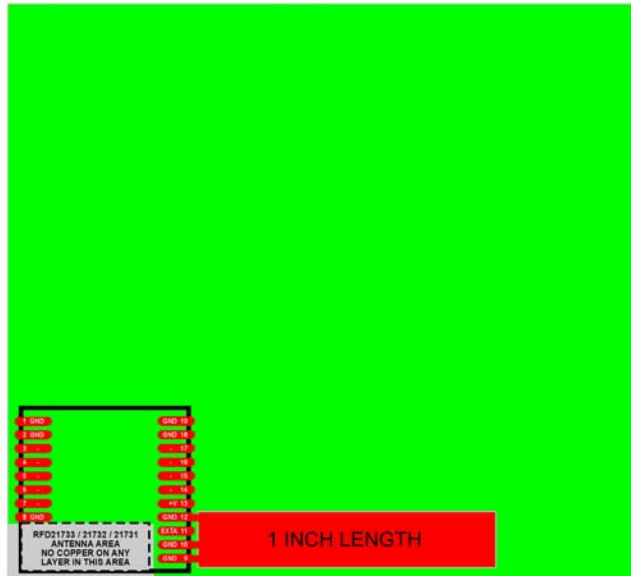
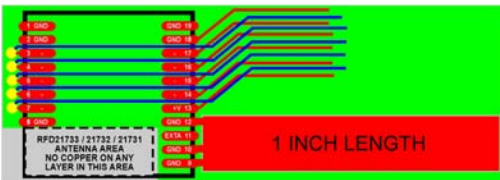
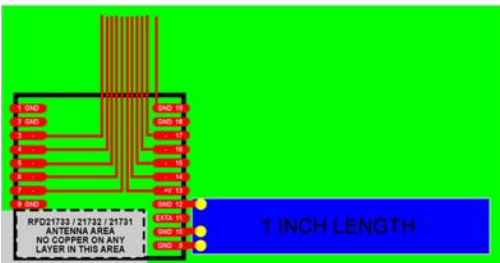
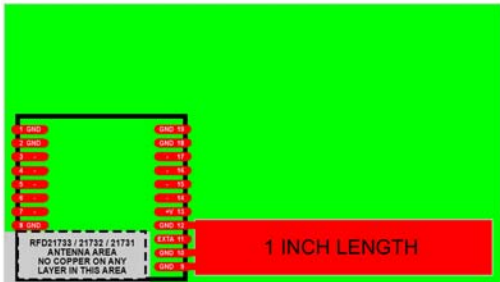
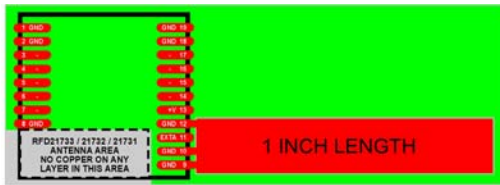

RFD21731, RFD21732, RFD21733 - Layout Examples 7

The gray area shows where to keep free from copper and components. The one-inch length copper area is optional, however does improve the range if you can add it. Parts can be placed all over the rest of the board, however if possible keep about a half-inch distance from the one inch length ground area to the right of the module, again, only if possible. Solid blue areas are solder side ground plane which can be used for user electronics as well as the module. These are all optional configurations and only for reference.

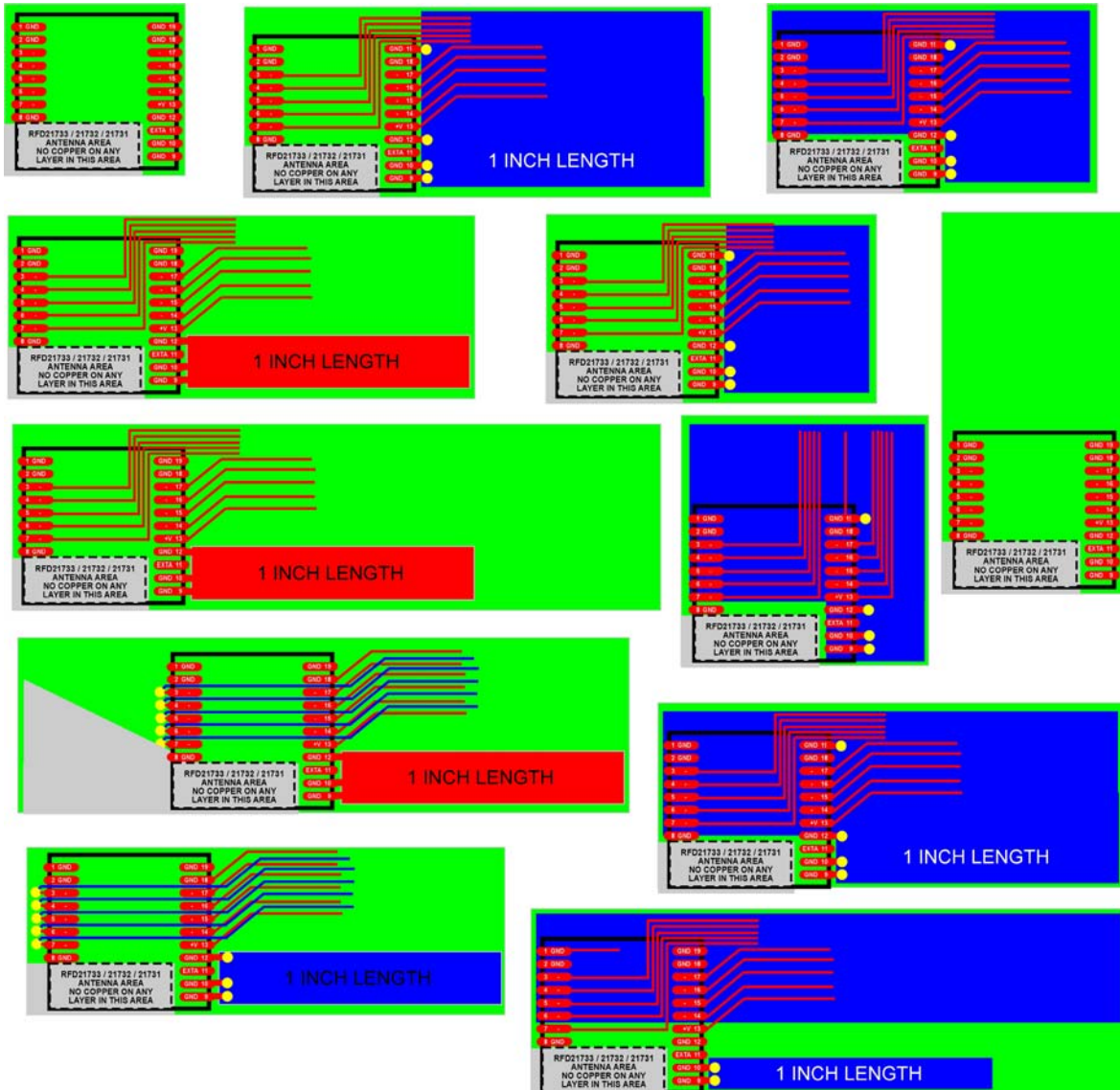

RFD21731, RFD21732, RFD21733 - Layout Examples 8

The gray area shows where to keep free from copper and components. The one-inch length copper area is optional, however does improve the range if you can add it. Parts can be placed all over the rest of the board, however if possible keep about a half-inch distance from the one inch length ground area to the right of the module, again, only if possible. Solid blue areas are solder side ground plane which can be used for user electronics as well as the module. These are all optional configurations and only for reference. The two left examples are preferred, but the two right ones will work as well, but will not have as good of an antenna pattern.

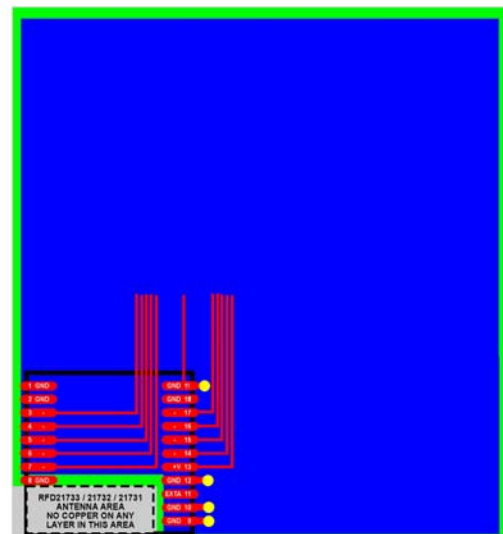
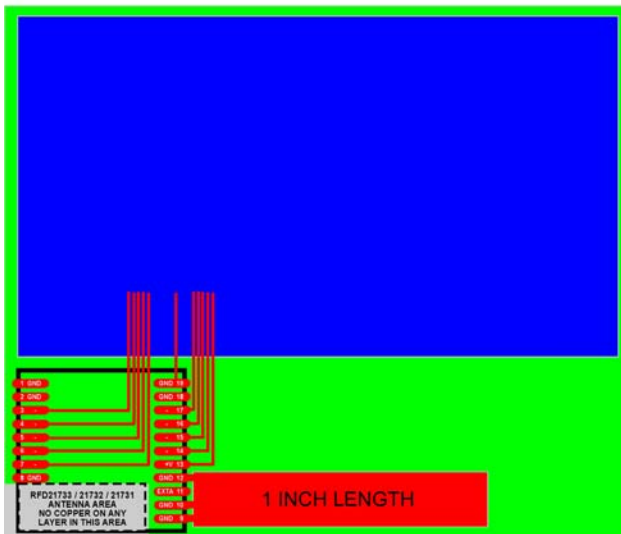
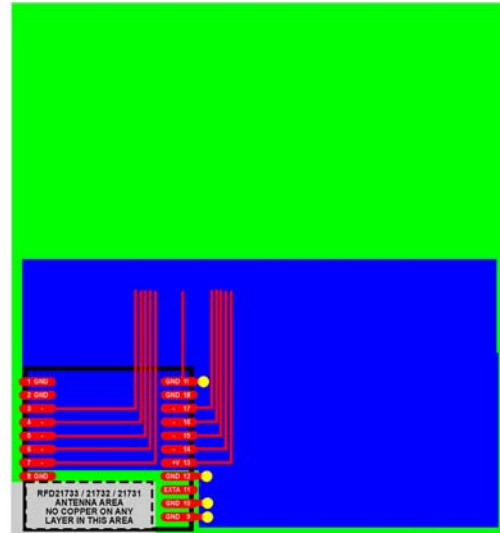
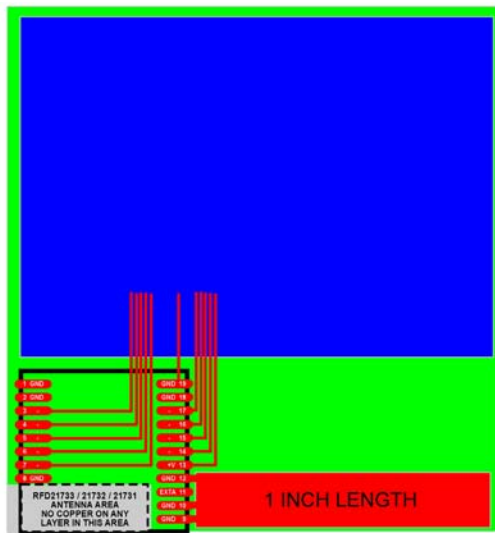

RFD21731, RFD21732, RFD21733 - Layout Examples 9

The gray area shows where to keep free from copper and components. The one-inch length copper area is optional, however does improve the range if you can add it. Parts can be placed all over the rest of the board, however if possible keep about a half-inch distance from the one inch length ground area to the right of the module, again, only if possible. Solid blue areas are solder side ground plane which can be used for user electronics as well as the module. These are all optional configurations and only for reference. The two left examples are preferred, but the two right ones will work as well, but will not have as good of an antenna pattern.

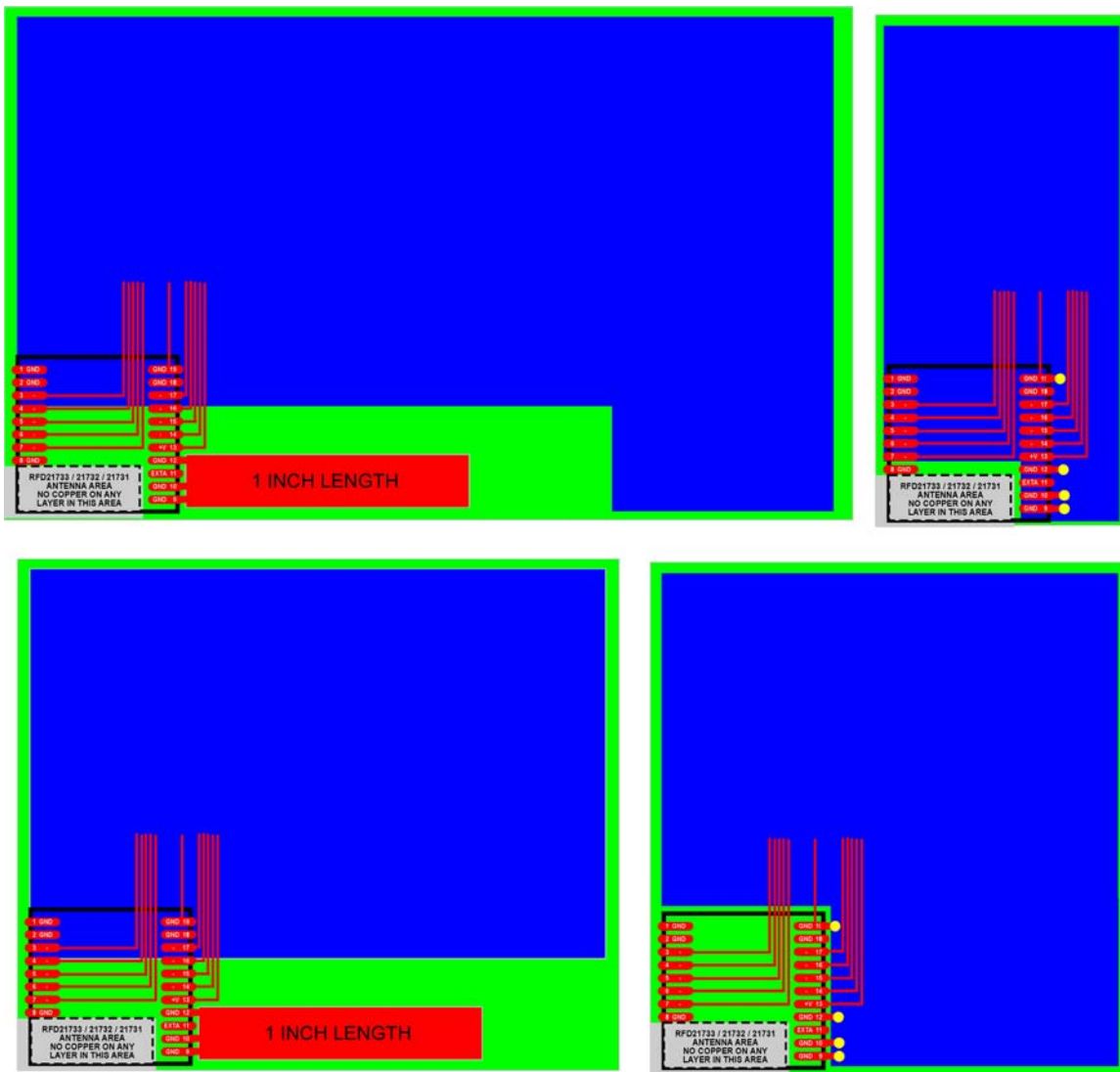

RFD21731, RFD21732, RFD21733 - Layout Examples 10

The gray area shows where to keep free from copper and components. The one-inch length copper area is optional, however does improve the range if you can add it. Parts can be placed all over the rest of the board, however if possible keep about a half-inch distance from the one inch length ground area to the right of the module, again, only if possible. Solid blue areas are solder side ground plane which can be used for user electronics as well as the module. These are all optional configurations and only for reference. The space in the ground plane helps provide some RF discontinuity for the module to have the best antenna pattern possible in this configuration, the optimal space to have is greater than 1.2 inches, but some space is better than no space.

BEST

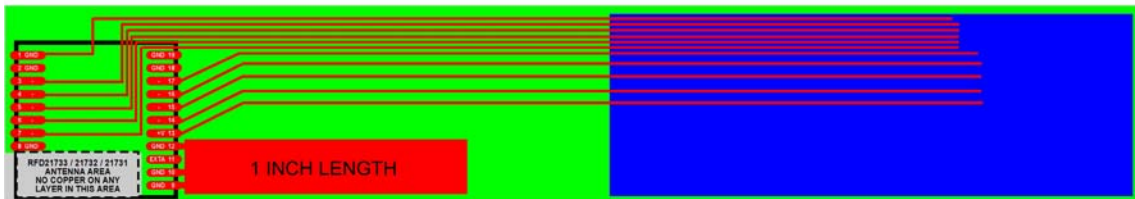
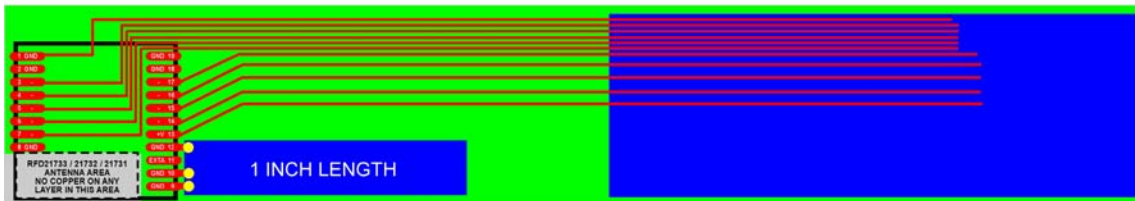

BETTER

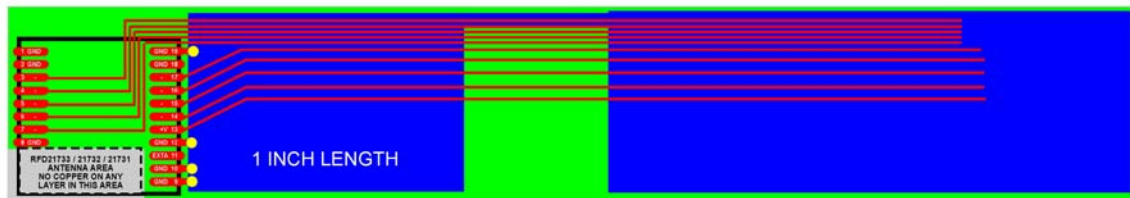

GOOD

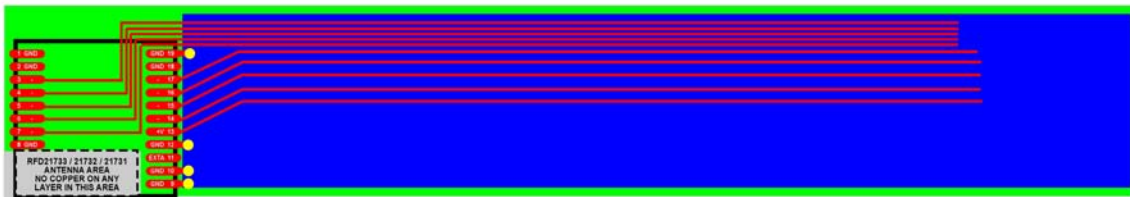

RFD21731, RFD21732, RFD21733 - Layout Examples 11

The gray area shows where to keep free from copper and components. These shown are not good layout locations for the module since they take up most of your board area, it is best to locate the module similar to the examples shown in other areas of this document where you have more board space for your parts. These examples are shown as what NOT to do. If you place parts in the gray area, it will result in very bad range performance.

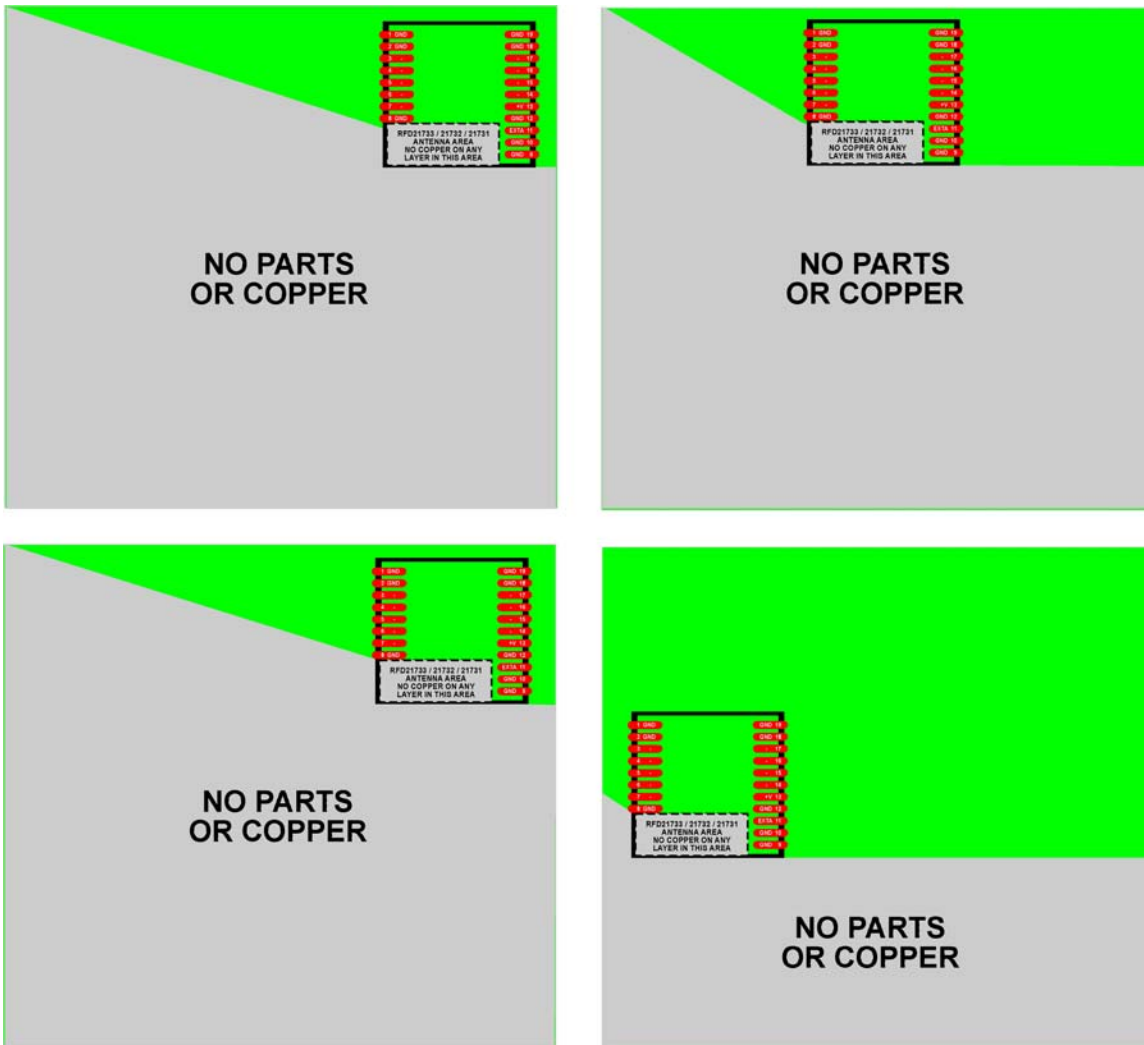

RFD21731, RFD21732, RFD21733 - Layout Examples 12

The gray area shows where to keep free from copper and components. These shown are not good layout locations for the module since they take up most of your board area, it is best to locate the module similar to the examples shown in other areas of this document where you have more board space for your parts. These examples are shown as what NOT to do. If you place parts in the gray area, it will result in very bad range performance.

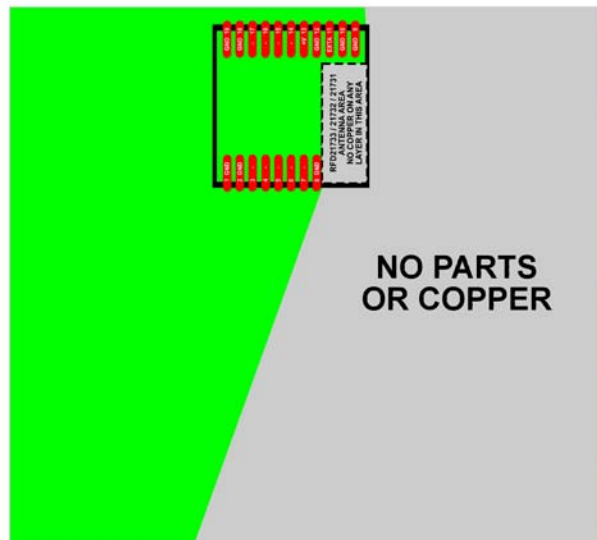
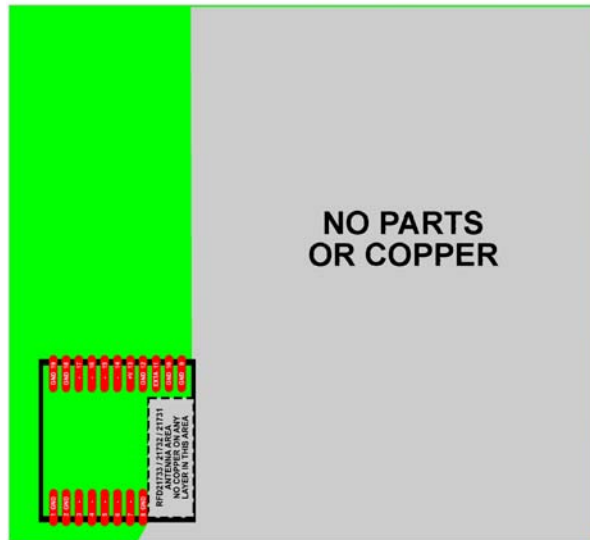
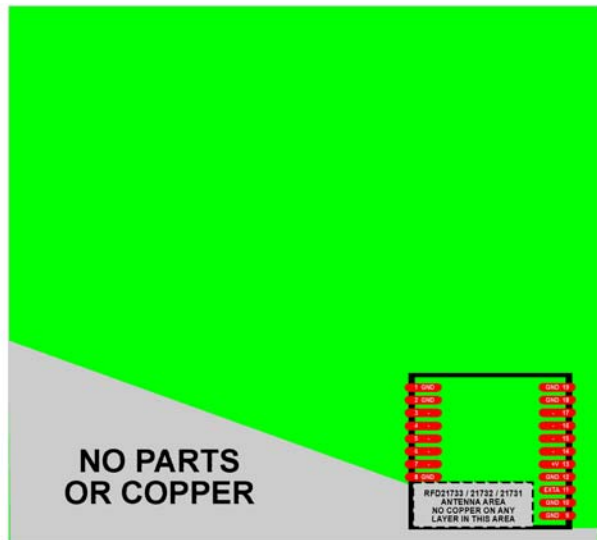
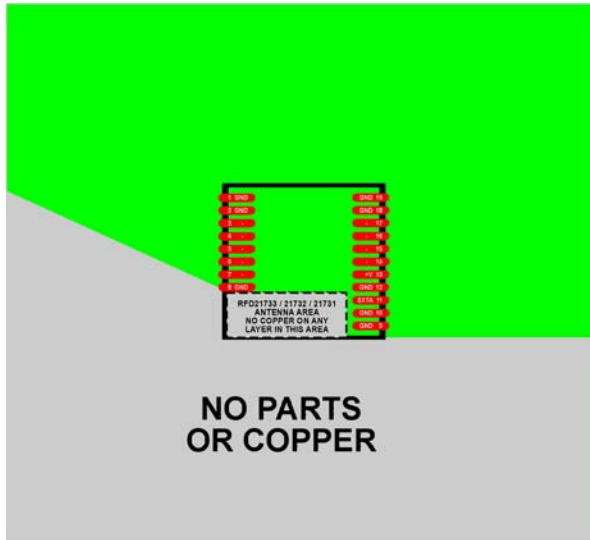

RFD21731, RFD21732, RFD21733 - Layout Examples 13

The gray area shows where to keep free from copper and components. These are multi-module configurations. Typical layouts for diversity applications where you will use multiple receivers, transmitters or transceivers all on the same board to limit multipath impacts and increase effective communication range or provide a very solid coverage area with limited dead-zones. The distances shown are not optimal, however just provided as reference.



RFD21731, RFD21732, RFD21733 - Layout Examples 14

The gray area shows where to keep free from copper and components. These are multi-module configurations. Typical layouts for diversity applications where you will use multiple receivers, transmitters or transceivers all on the same board to limit multipath impacts and increase effective communication range or provide a very solid coverage area with limited dead-zones. The distances shown are not optimal, however just provided as reference.

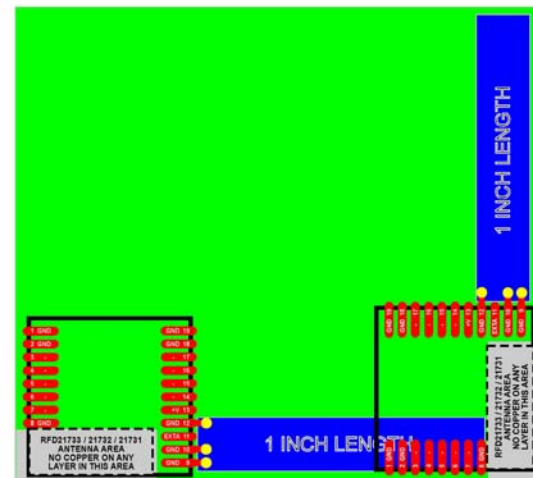
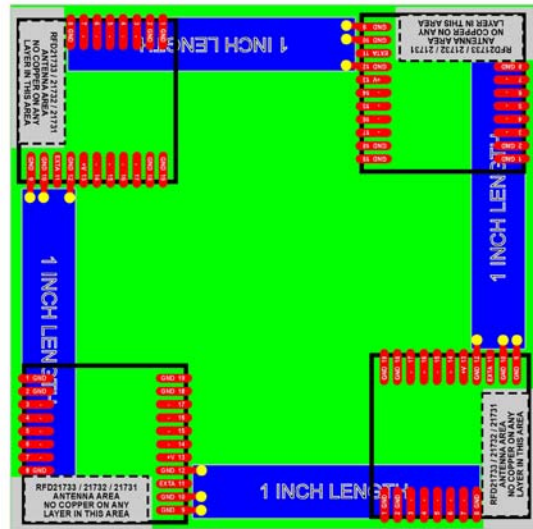
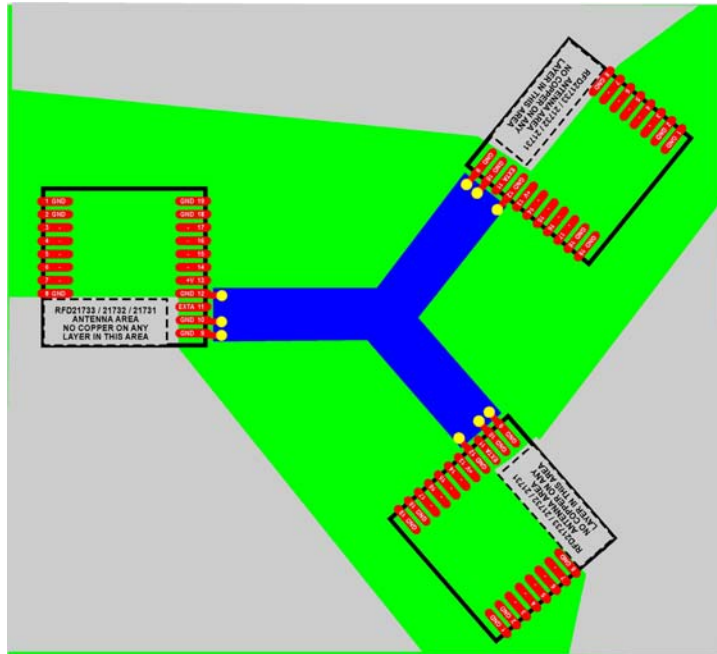

RFD21734 and RFD21735 - Layout Examples 15

The gray area shows where to keep free from copper and components. The RFD21734 and RFD21735 require the use of an external antenna and therefore the most common connector used for this is an SMA and the examples below show a typical SMA connector footprint interface.

PCB thickness is 0.031 inch to 0.062 inch, double sided. The blue color shows ground plane under the module on the solder side of the board.

If you place ground plane or any traces under the gray area marked no-copper, then you will not have the option to use the RFD21731 / RFD21732 / RFD21733 which are the on-board chip antenna versions of the RFD21734 / RFD21735. So it is your choice if you choose to flood copper under that area or not. There is no benefit to flood copper in that area. If you choose to make a dual-mode layout to handle both module options, with chip antenna or without (which is what we recommend), then also advise with the layout configurations above for proper application.

We highly recommend that you look at the RFD21743 before starting a design with the RFD21734 or RFD21735. The RFD21743 is the RF Digital Worldwide Patent Pending RFDANT which is a full RF Module in an antenna form factor (FCC approval pending) allowing you to simply plug it into any product and not needing to do any RF layouts or deal with connectors or cables, in addition to having exceptional range. Save time, money and no need for additional compliance approvals.

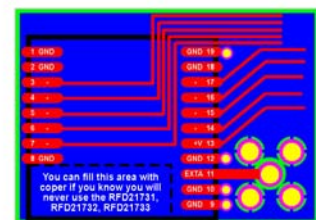
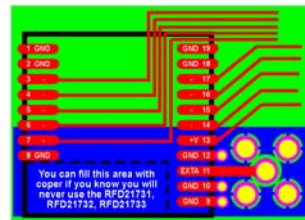
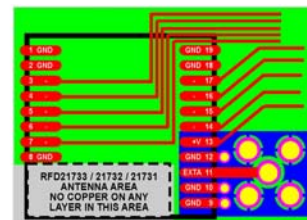
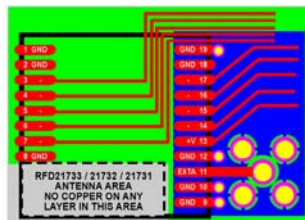
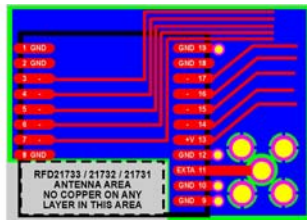

© Copyright,
RF Digital Corp.
7/25/2010 11:04 AM
Patents Pending

RoHS

RFD21733

FCC APPROVED

RF DIGITAL
C O R P O R A T I O N

13715 Alton Pkwy • Irvine • CA • 92618

Tel: 949.610.0008 • Fax: 949.610.0009

www.rfdigital.com • sales@rfdigital.com

Layout Examples

RFDANT	RF Module
RFD21743	RFD21731
RFD21741	RFD21732
	RFD21733
	RFD21734
	RFD21735

ETSI • CE Compliant

Important Notice

RF Digital reserves the right to make corrections, modifications, and/or improvements to the product and/or its specifications at any time without notice.

RF Digital assumes no liability for the user's product and/or applications.

RF Digital products are not authorized for use in safety-critical applications, including but not limited to life-support applications.

RF Digital assumes no liability for parts or their application beyond replacement or refunding the original purchase price.

All trademarks and trade names belong to their respective owners.

End of Document.

Mouser Electronics

Authorized Distributor

Click to View Pricing, Inventory, Delivery & Lifecycle Information:

[RF Digital:](#)

[RFD21731](#) [RFD21732](#) [RFD21734](#)