

HITACHI

Displays, Hitachi, Ltd.
3300 Hayano, Mobara City
Chiba Pref. 297-8622 Japan
TEL : +81-475-25-9005 (Dial In)
FAX : +81-475-22-5217

液晶之友 电话: 020-33819057
[Http://www.lcdfriends.com](http://www.lcdfriends.com)

For Messrs :

Date : Nov. 27, 2000

CUSTOMER'S ACCEPTANCE SPECIFICATIONS SC09Q002-AZA

CONTENTS

No.	ITEM	Sheet No.	Page
1	COVER	3284PS 2701 - SC09Q002-AZA - 2	1-1/1
2	RECORD OF REVISIONS	3284PS 2702 - SC09Q002-AZA - 2	2-1/1
3	GENERAL DATA	3284PS 2703 - SC09Q002-AZA - 2	3-1/1
4	ABSOLUTE MAXIMUM RATINGS	3284PS 2704 - SC09Q002-AZA - 2	4-1/2~ 4-2/2
5	ELECTRICAL CHARACTERISTICS	3284PS 2705 - SC09Q002-AZA - 2	5-1/3~ 5-3/3
6	OPTICAL CHARACTERISTICS	3284PS 2706 - SC09Q002-AZA - 2	6-1/4~ 6-4/4
7	BLOCK DIAGRAM	3284PS 2707 - SC09Q002-AZA - 2	7-1/1
8	INTERFACE TIMING DIAGRAM	3284PS 2708 - SC09Q002-AZA - 2	8-1/6~ 8-6/6
9	DIMENSIONAL OUTLINE	3284PS 2709 - SC09Q002-AZA - 2	9-1/1
10	APPEARANCE STANDARD	3284PS 2710 - SC09Q002-AZA - 2	10-1/5~ 10-5/5
11	PRECAUTION IN DESIGN	3284PS 2711 - SC09Q002-AZA - 2	11-1/3~ 11-3/3
12	DESIGNATION OF LOT MARK	3284PS 2712 - SC09Q002-AZA - 2	12-1/2~ 12-2/2
13	PRECAUTION FOR USE	3284PS 2713 - SC09Q002-AZA - 2	13-1/1

Accepted by : _____

Proposed by : _____

Displays, Hitachi, Ltd.	Sh. No.	3284PS 2701 - SC09Q002-AZA - 2	Page	1-1/1
-------------------------	------------	--------------------------------	------	-------

RECORD OF REVISIONS

Date	Sheet No.	Summary
Nov.27,2000	3284PS 2705-SC09Q002-AZA-2 Page 5-2/3	5.2 ELECTRICAL CHARACTERISTICS OF BACK LIGHT Revised (Note 1)
	3284PS 2706-SC09Q002-AZA-2 Page 6-1/4	6.1.1 REFLECTION MODE Contrast Ratio (MIN) : - → (4)
	3284PS 2706-SC09Q002-AZA-2 Page 6-2/4	6.1.2 TRANSMISSIVE MODE Contrast Ratio (MIN) : - → (10)
	3284PS 2707-SC09Q002-AZA-2 Page 7-1/1	7. BLOCK DIAGRAM Revised
	3284PS 2708-SC09Q002-AZA-2 Page 8-1/6	8.1 TIMING DIAGRAM FLM : (240+n)×T → 245×T
	3284PS 2709-SC09Q002-AZA-2 Page 9-1/1	9. DIMENSIONAL OUTLINE Revised
	3284PS 2710-SC09Q002-AZA-2 Page 10-4/5	10.3 APPEARANCE SPECIFICATION (3) TOUCH PANEL APPEARANCE Chip and Crack : Deleted Chip reaching glass pattern
	3284PS 2712-SC09Q002-AZA-2 Page 12-1/2	12.1 LOT MARK Revised
	3284PS 2712-SC09Q002-AZA-2 Page 12-2/2	12.2 REVISION Revised

3. GENERAL DATA

- (1) Part Name SC09Q002-AZA
- (2) Module Dimensions 92.1(W) mm × 71.0(H) mm × 9.0 max (D) mm
- (3) Dot Size 0.057(W) mm × 0.211(H) mm
- (4) Dot Pitch 0.077(W) mm × 0.231(H) mm
- (5) Resolution 320 × 3 (R,G,B)(W) × 240 (H) dots
- (6) Duty Ratio 1/245
- (7) LCD Type Transflective Color LCD (negative type)
The upper polarizer is glare type
- (8) Display Type Passive Matrix Color STN
- (9) View ing Direction 6 O'clock
- (10) Back Light Light Emitting Diode (LED)
- (11) Pow er Consumption 13mW : Back light off
317mW : Back light on
- (12) Reflectance (22%) : Back light off
- (13) Weight (68) g
- (14) Pow er Supply Voltage 3.3V only
- (15) Touch Panel Resistance Type

(16) Recommended Controller

Type No.	Supplier	Portrait mode operation	Availability
SED1354	Epson	Soft w ise	Available
SED1355	Epson	Hard w ise	Available
SED1374	Epson	Hard w ise	Available

4. ABSOLUTE MAXIMUM RATINGS

4. 1 ELECTRICAL ABSOLUTE MAXIMUM RATINGS OF LCD

VSS=0V

ITEM	SYMBOL	MIN	MAX	UNIT	COMMENT
Power Supply for Logic	VDD	0	4.0	V	
Contrast Adjustment Voltage	VCON	1	VDD	V	
Input Voltage	V _i	-0.3	VDD+0.3	V	Note 1
Input Current	i _i	0	1	A	
Static Electricity	-	-	(±8)	kV	Note 2

Note 1 $\overline{\text{DISP}} \bullet \text{OFF}$, FLM, CL1, CL2, D0~D7

Note 2 200pF-250Ω, 25°C-70%RH, The Surface of metal bezel and LCD panel are subjected.

4. 2 ENVIRONMENTAL ABSOLUTE MAXIMUM RATINGS

ITEM	OPERATING		STORAGE		COMMENT
	MIN	MAX	MIN	MAX	
Ambient Temperature	5°C	40°C	-20°C	60°C	Note 2, 3
Humidity	Note 1		Note 1		Without condensation
Vibration	-	2.45 m/s ²	-	11.76 m/s ² Note 5	Note 4, 7
Shock	-	29.4 m/s ²	-	490 m/s ² Note 5	XYZ directions Note 7
Corrosive Gas	Not Acceptable		Not Acceptable		

Note 1 $T_a \leq 40^\circ\text{C}$: 85%RH max.

$T_a > 40^\circ\text{C}$: Absolute humidity must be lower than the humidity of 85%RH at 40°C.

Note 2 T_a at -20°C for 48h, at 60°C for 168h

Note 3 Background color changes slightly depending on ambient temperature.
This phenomenon is reversible.

Note 4 5Hz~100Hz (Except resonance frequency)

Note 5 The LCM will resume normal operation after finishing the test.

Note 6 The response time will be slower at 5°C.

Note 7 The module has no mounting hole.

It should be fixed by the same sandwiching-like method. (Fig.1)

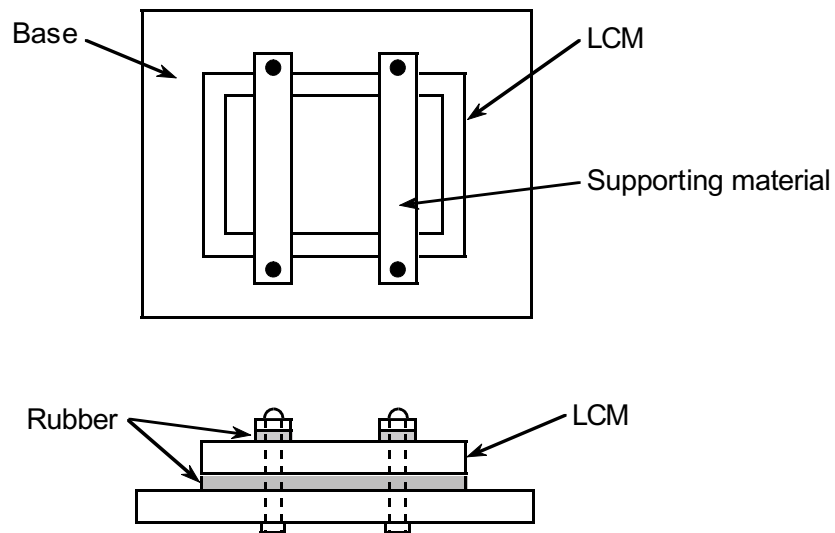

Fig. 1

5. ELECTRICAL CHARACTERISTICS

5. 1 ELECTRICAL CHARACTERISTICS OF LCD

VSS=0V

ITEM	SYMBOL	CONDITION	MIN	TYP	MAX	UNIT
Power Supply Voltage	VDD	VDD-VSS=3.3V	3.15	3.30	3.45	V
Contrast Adjustment Voltage (Note 1)	VCON	-	1	-	VDD-0.3	V
Input Voltage for Logic Circuits (Note 2)	Vi	"H" level	0.8VDD	-	VDD	V
		"L" level	0	-	0.2VDD	
Power Supply Current (Note 3)	IDD	VDD-VSS=3.3V	-	4	8	mA
Input Leak Current	I _{con} (Note4)	V _{con} =1~3V	-	-	±10	μA
	I _{in} (Note2)	V _{in} =VDDorVSS	-	-	±5.0	
Contrast Adjustment Voltage (Note 5)	V _{con}	T _a = 5°C, φ=0°	-	(2.1)	(2.5)	V
		T _a =25°C, φ=0°	(1.6)	(2.0)	(2.4)	
		T _a =40°C, φ=0°	(1.3)	(1.7)	-	
Frame Frequency (Note 6)	fFLM	-	60	70	100	Hz

(Note 1) In proportion as the VCON voltage increase the brightness will increase.

(Note 2) DISP•OFF, FLM, CL1, CL2, D0~D7

(Note 3) fFLM=70Hz, T_a=25°C, V_{con}=2.0V, Pattern used as display pattern : All White.

(Note 4) VCON

(Note 5) fFLM=70Hz, Duty=1/245

The Contrast Adjustment Voltage is specified as (2.0±0.4)V under the condition that optimum contrast is obtained by naked eyes with a "Q" test pattern.

(Note 6) Please set the frame frequency so as to avoid flicker and ripples on the display.

(Note 7) Some points for attention while setting the driving condition of an appliance.

(1) Frame Frequency

Please set the frame frequency as the typical value (central value) which is shown in CAS. According to the characteristic of response time of LC material, that setting the frame frequency near the minimum value or under the minimum value shown in CAS will cause a frame with moving phenomenon.

(2) Setting value of V_{con}

V_{con}, adjusted to get the best contrast ratio of LCD module, is adjusted to be distributed within the tolerance ±0.3V of central value in CAS before LCD modules ship the factory. The below items are recommended at customer side.

(i) When designing the appliance, please set the V_{con} value as an adjustable value.

(ii) And the V_{con} value must be able to be adjusted to match the most suitable V_{con} to get the best contrast ratio. A fixed V_{con} value is usually a little different from the most suitable V_{con} value of LCD module and causes a misjudgment.

(iii) The V_{con} adjustment (when D/A [Digital/Analogue] converter is used) is recommended to be set as 50mV at most per step. That one step is more than 50mV may cause the input value to be not able to match the most suitable value.

The characteristic of contrast ratio can not present absolutely.

Displays, Hitachi, Ltd.	Date	Nov. 27, 2000	Sh. No.	3284PS 2705 - SC09Q002-AZA - 2	Page	5-1/3
----------------------------	------	---------------	------------	--------------------------------	------	-------

5. 2 ELECTRICAL CHARACTERISTICS OF BACK LIGHT

ITEM	SYMBOL	MIN	TYP	MAX	UNIT	NOTE
LED Power Supply Voltage (Note 1)	V _F	-	3.8	3.9	V	Ta=25°C
LED Power Supply Current (Note 1)	I _F	-	80	90	mA	Ta=25°C

(Note 1)

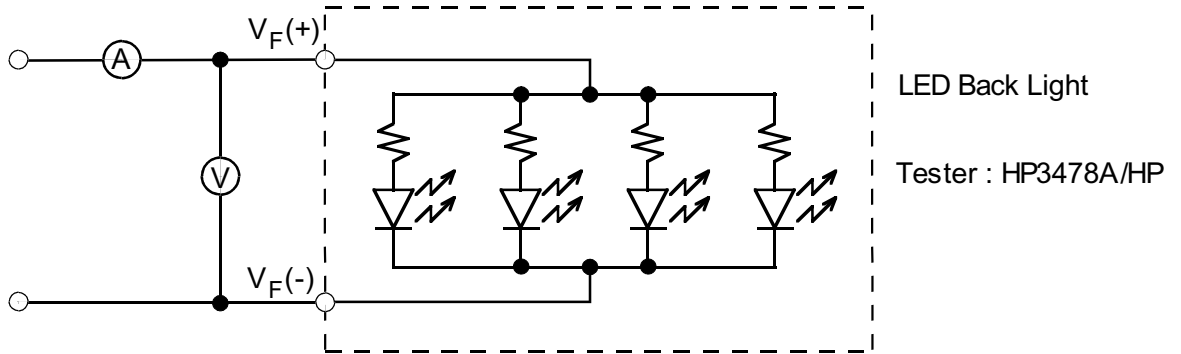

5.3 ELECTRICAL CHARACTERISTICS OF TOUCH PANEL

5.3.1 OPERATING CONDITION

ITEM	SPECIFICATION
Operating Voltage	5VDC
Operating Current	T.B.D

5.3.2 ELECTRICAL CHARACTERISTICS

ITEM		SPECIFICATION	NOTE
Resistance between terminal	X1-X2	180~1070Ω	
	Y1-Y2	150~850Ω	
Insulance Resistance	X-Y	10MΩ min	Operating Voltage 25VDC
Linearity	X	1.5% max	(Note 1)
	Y	1.5% max	
Chattering		15msec max	

5.3.3 MECHANICAL CHARACTERISTICS

ITEM	SPECIFICATION	NOTE
Pen input pressure	1N max	R0.8mm polyacetal pen
Surface hardness	2H min	JIS K 5400

(Note 1)

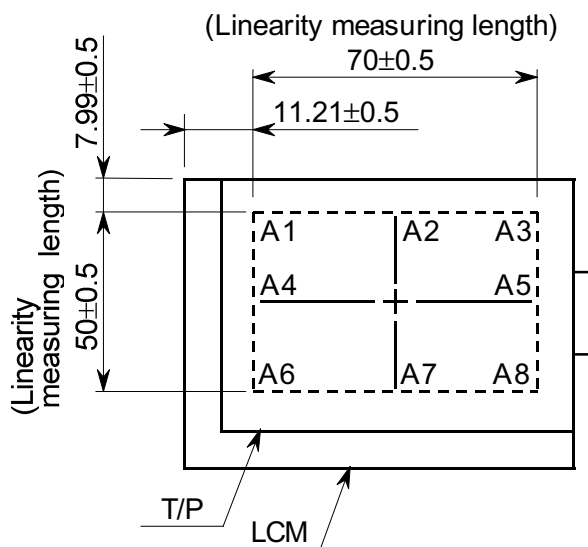

(Measuring method)

$$\text{Linearity}(\%) = \frac{\Delta V}{EV - SV} \times 100$$

ΔV : The difference between the ideal voltage and measured voltage on the each measuring line.

SV : Voltage of Starting Points
(X axis:A1,A4,A6, Y axis:A1,A2,A3)

EV : Voltage of Ending Points
(X axis:A3,A5,A8, Y axis:A6,A7,A8)

Measuring line X axis:A1-A3, A4-A5, A6-A8
Y axis:A1-A6, A2-A7, A3-A8

6. OPTICAL CHARACTERISTICS

6.1 OPTICAL CHARACTERISTICS OF LCD

6.1.1 REFLECTION MODE

Ta=25°C

ITEM	SYMBOL	CONDITION	MIN	TYP	MAX	UNIT	NOTE
Reflectance	R	$\phi=0^\circ, \theta=0^\circ$	-	(22)	-	%	1)
Viewing angle	$\phi_2-\phi_1$	$\theta=0^\circ, K \geq 2.0$	-	(60)	-	deg	2),3)
		$\theta=90^\circ, K \geq 2.0$	-	(60)	-		
Contrast ratio	K	$\phi=0^\circ, \theta=0^\circ$	(4)	(8)	-	-	1),4),6), 7)
Response time (rise+fall)	tr+tf	$\phi=0^\circ, \theta=0^\circ$	-	(300)	-	ms	5)
Color tone (Primary Color)	Red	x	$\phi=0^\circ, \theta=0^\circ$	-	T.B.D	-	8),9)
		y		-	T.B.D	-	
	Green	x		-	T.B.D	-	
		y		-	T.B.D	-	
	Blue	x		-	T.B.D	-	
		y		-	T.B.D	-	
	White	x		-	T.B.D	-	
		y		-	T.B.D	-	

(Measurement condition : Hitachi standard)
Note 2)~9) : See Page 6-3/4.

Note 1. Definition of Reflectance R

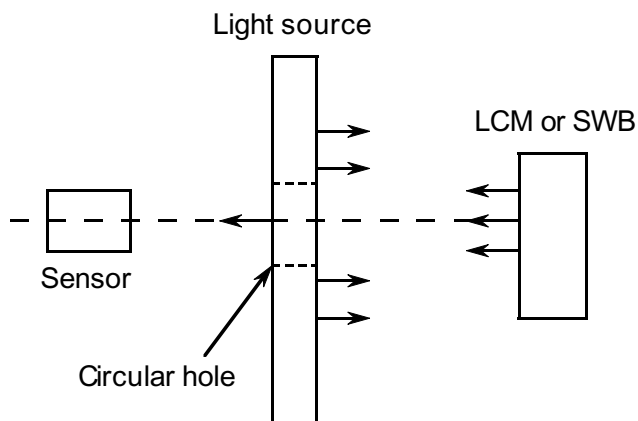

$$R = \frac{BLCM}{BSWB}$$

BLCM : Brightness of LCM at optimum voltage.
(Displaying white pattern)

BSWB : Brightness of SWB.

SWB : Standard white board.

6.1.2 TRANSMISSIVE MODE

Ta=25°C

ITEM		SYMBOL	CONDITION	MIN	TYP	MAX	UNIT	NOTE
Viewing angle		$\phi_2-\phi_1$	$\theta=0^\circ, K \geq 2.0$	-	(60)	-	deg	2),3)
			$\theta=90^\circ, K \geq 2.0$	-	(60)	-		
Contrast ratio		K	$\phi=0^\circ, \theta=0^\circ$	(10)	(20)	-	-	1),4),6),7)
Response time (rise+fall)		tr+tf	$\phi=0^\circ, \theta=0^\circ$	-	(300)	-	ms	5)
Color tone (Primary Color)	Red	x	$\phi=0^\circ, \theta=0^\circ$	-	T.B.D	-	-	8)
		y		-	T.B.D	-	-	
	Green	x		-	T.B.D	-	-	
		y		-	T.B.D	-	-	
	Blue	x		-	T.B.D	-	-	
		y		-	T.B.D	-	-	
	White	x		-	T.B.D	-	-	
		y		-	T.B.D	-	-	

(Measurement condition : Hitachi standard)

Note 2)~8) : See Page 6-3/4.

Note 2. Definition of θ and ϕ

(Normal)

Viewing direction

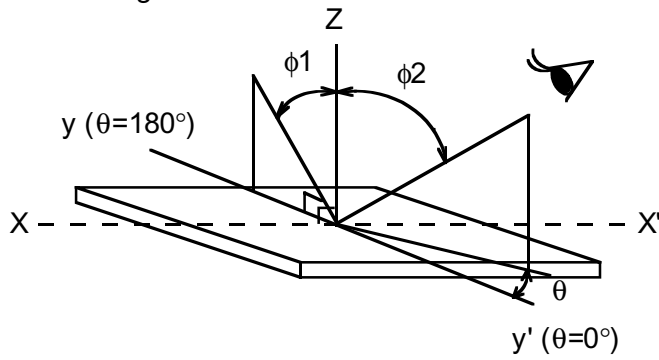

Note 4. Definition of contrast "K"

$$K = \frac{\text{Brightness of selected area (B1)}}{\text{Brightness of non-selected area (B2)}}$$

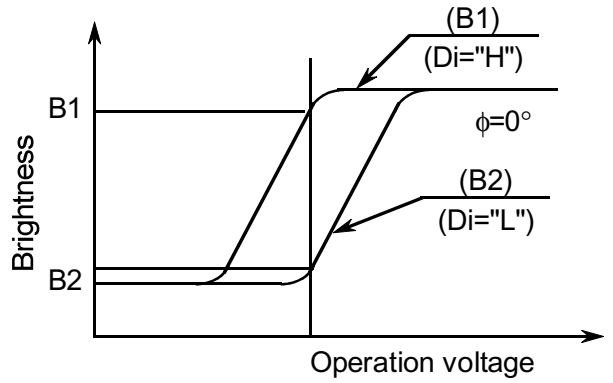

Note 3. Definition of view ing angle ϕ_1 and ϕ_2

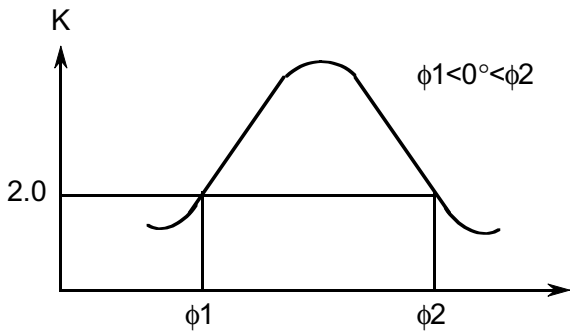

Contrast ratio K vs view ing angle ϕ

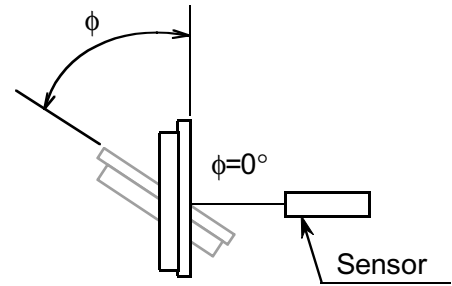

Sensor : BM-5 or similar equipment

Note 5. Definition of optical response time

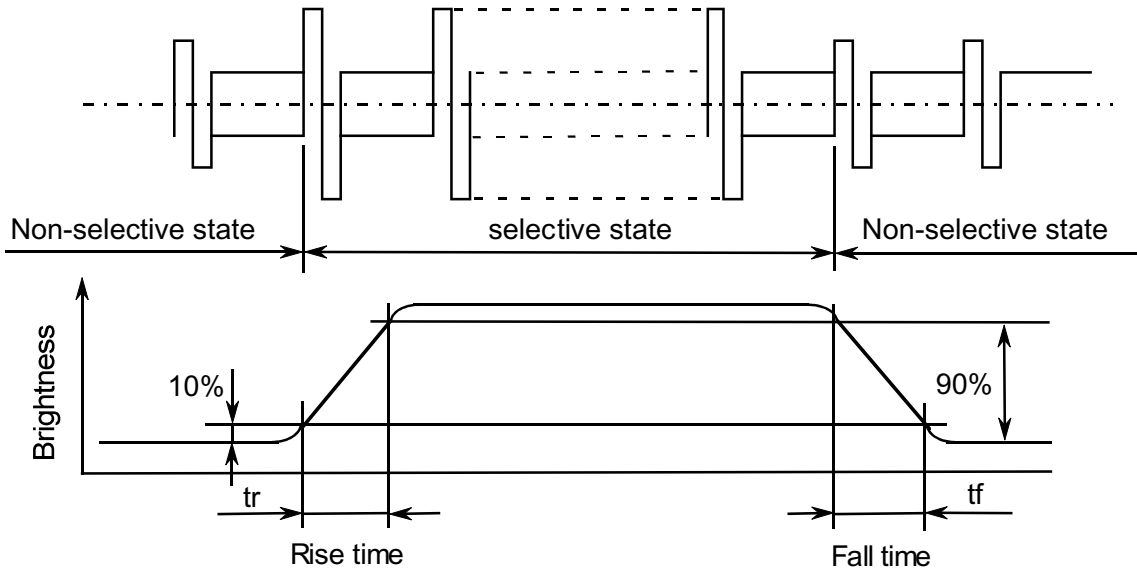

Note 6. Minimum value is for reference only.

Note 7. Hitachi will do sampling inspection for minimum value.

Note 8. The LCD driving voltage should be adjusted as to obtain maximum contrast.

Note 9. The color temperature of light source is 5200K.

Displays, Hitachi, Ltd.	Date	Nov. 27, 2000	Sh. No.	3284PS 2706 - SC09Q002-AZA - 2	Page	6-3/4
----------------------------	------	---------------	------------	--------------------------------	------	-------

6.2 OPTICAL CHARACTERISTICS OF BACK LIGHT

ITEM	MIN	TYP	MAX	UNIT	NOTE
Brightness	-	(6)	-	cd/m ²	IF=80mA Note 1),2)
Brightness Uniformity	-	(±30)	-	%	IF=80mA Note 1)~4)

(Measurement condition : Hitachi standard)

(Note 1) Ta=25°C

Display data should all be "ON"

The LCD driving voltage should be adjusted so as to obtain maximum contrast when display pattern is all "Q".

(Note 2) Measurement after 5 minutes of LED operating.

Average value of 5 measurement locations (Note 3).

(Note 3) Measurement on the following 5 locations on the display.

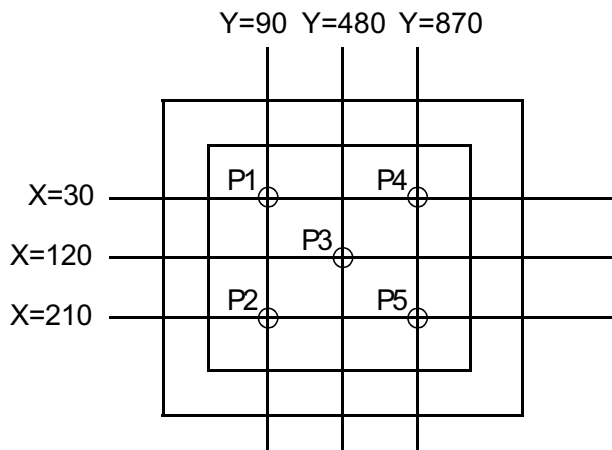

(Note 4) Definition of brightness tolerance.

$$\left(\frac{\text{Max brightness or Min brightness} - \text{Average brightness}}{\text{Average brightness}} \right) \times 100$$

7. BLOCK DIAGRAM

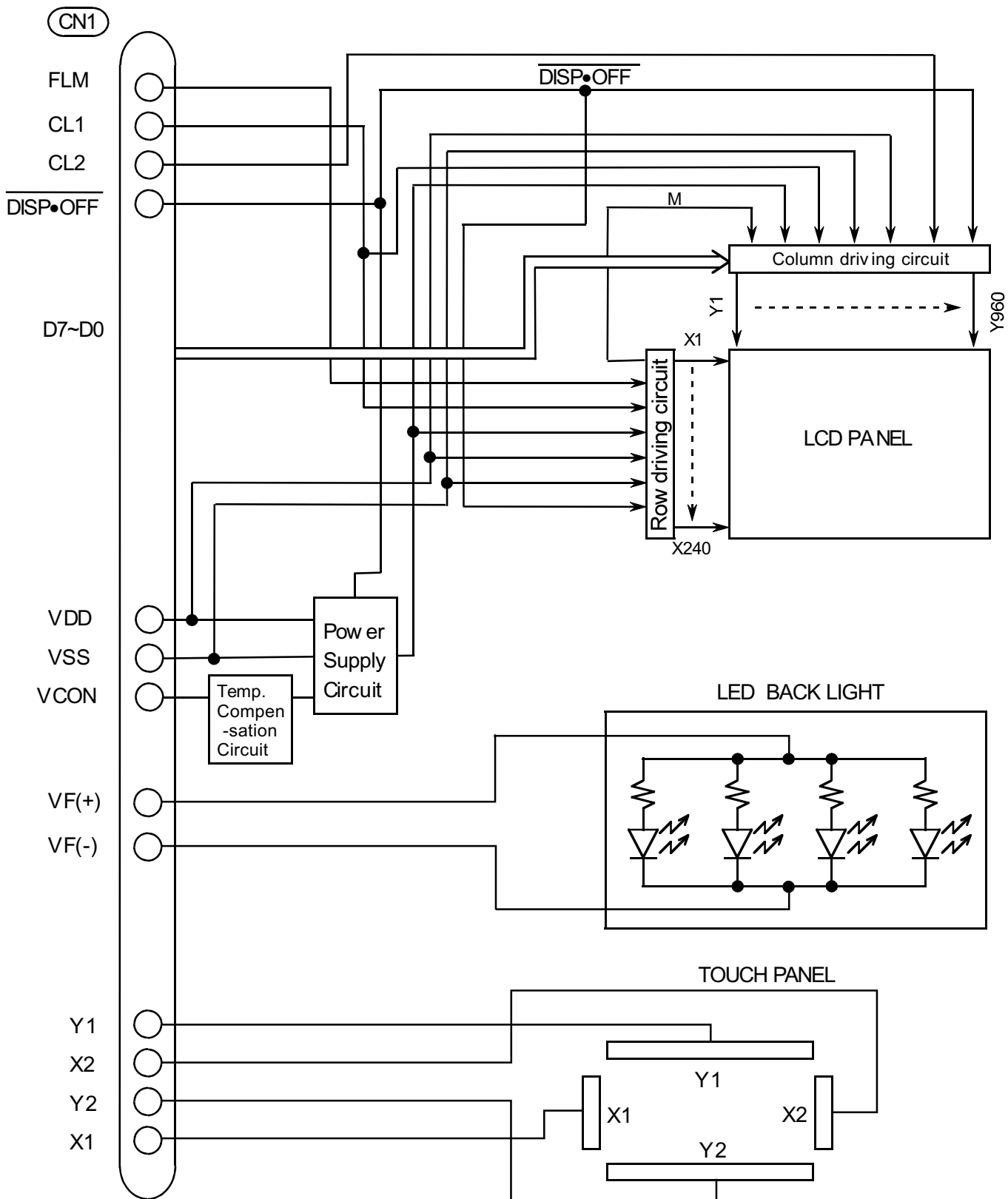

8. INTERFACE TIMING DIAGRAM

8.1 TIMING DIAGRAM

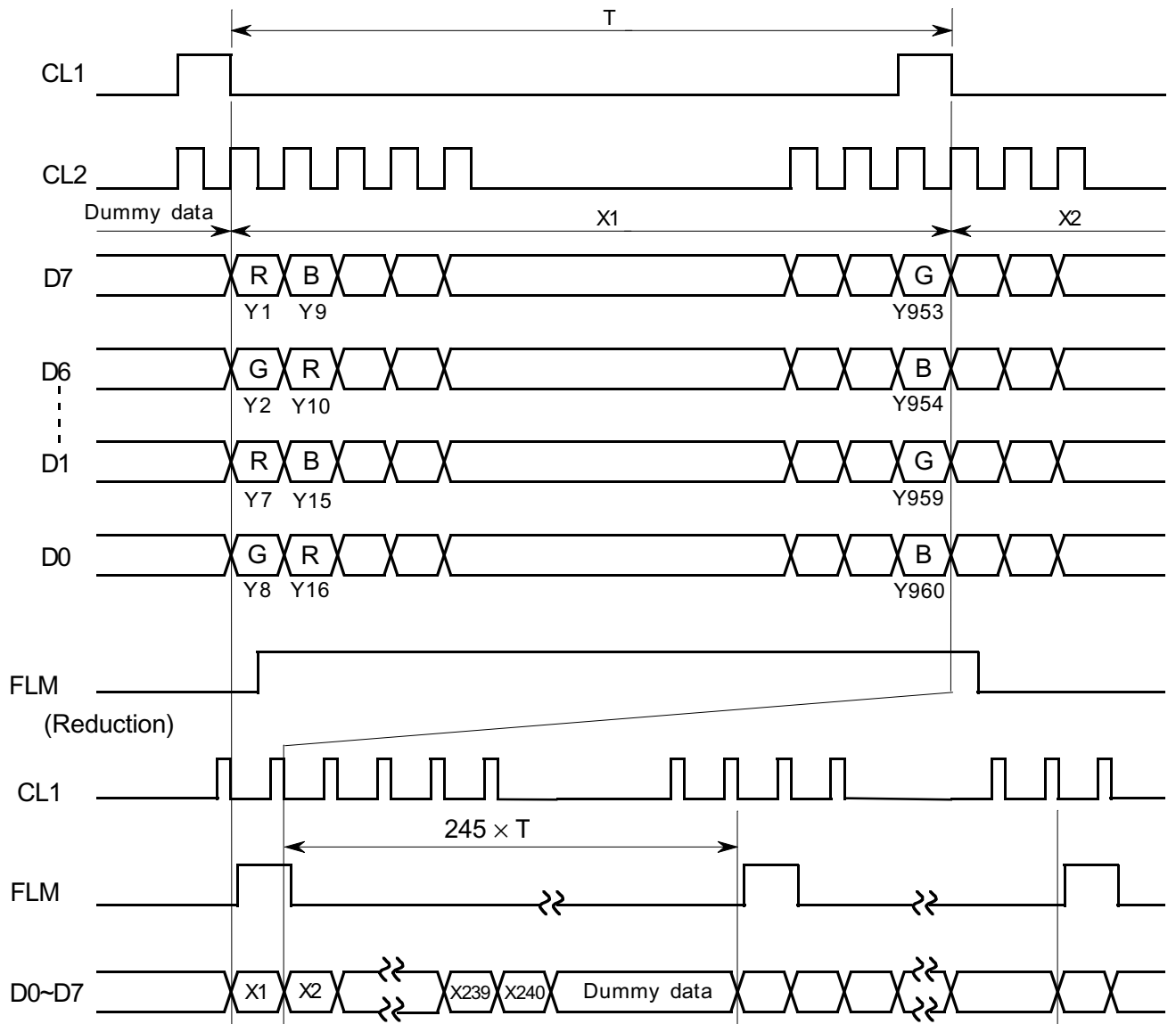

8.2 INTERFACE TIMING SPECIFICATION

(VDD=3.3±0.15V, VSS=0V, Vcon=1.0~(VDD-0.3), Ta=+5°C~+40°C)

ITEM	SYMBOL	MIN	TYP	MAX	UNIT
CL1 pulse width "H"	t _{WHCL1}	100	—	—	ns
Clock cycle time	t _{CYC}	60	—	—	ns
CL2 pulse width	t _{WCL2}	30	—	—	ns
Clock set up time	t _{SCL1}	40	—	—	ns
Clock hold time	t _{HCL1}	80	—	—	ns
Clock rise fall time	t _r , t _f	—	—	30	ns
Data set up time	t _{DSU}	20	—	—	ns
Data hold time	t _{DH}	20	—	—	ns
"FLM" set up time	t _{FS}	100	—	—	ns
"FLM" hold time	t _{FH}	50	—	—	ns

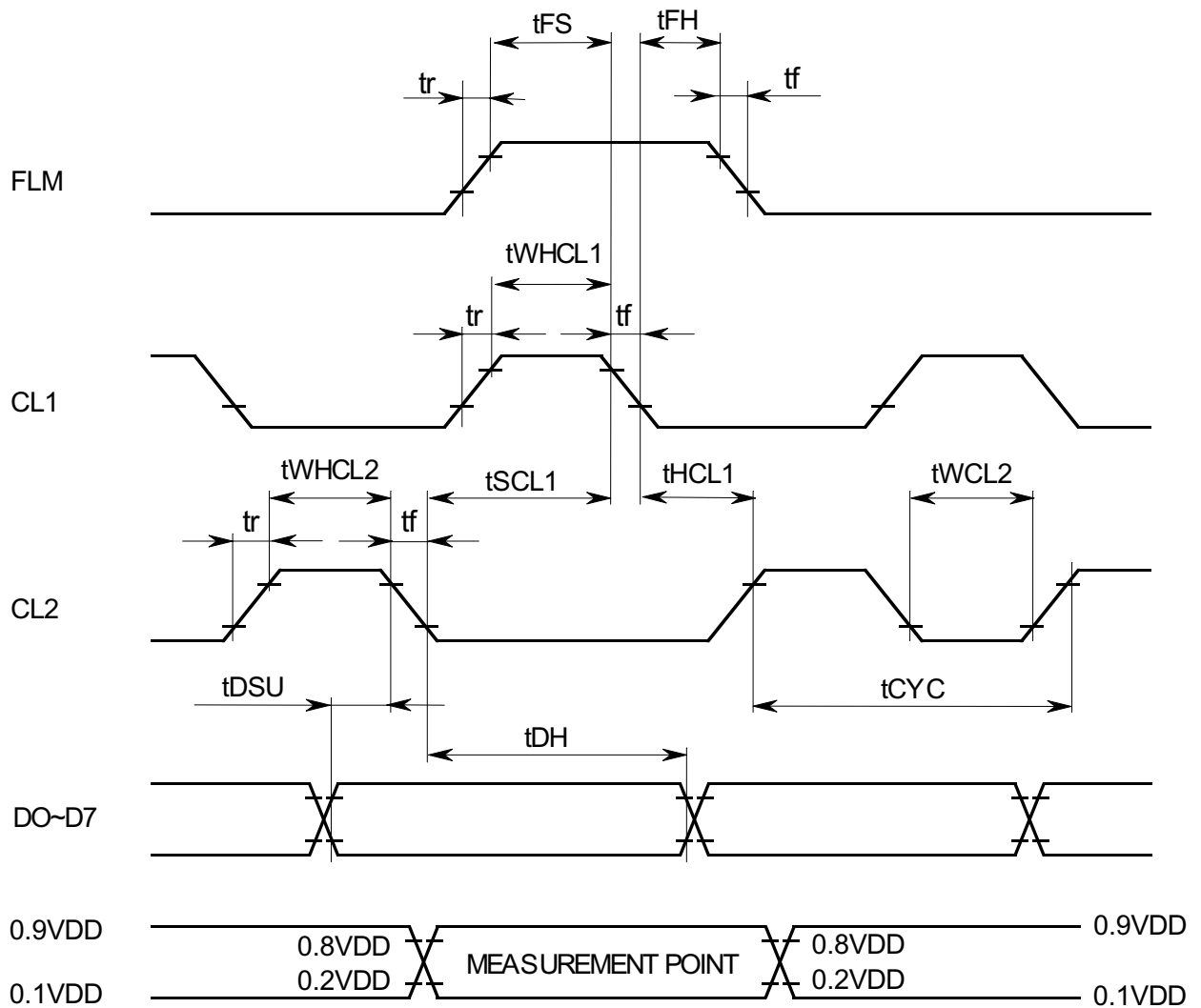

8.3 POWER ON / OFF SEQUENCE

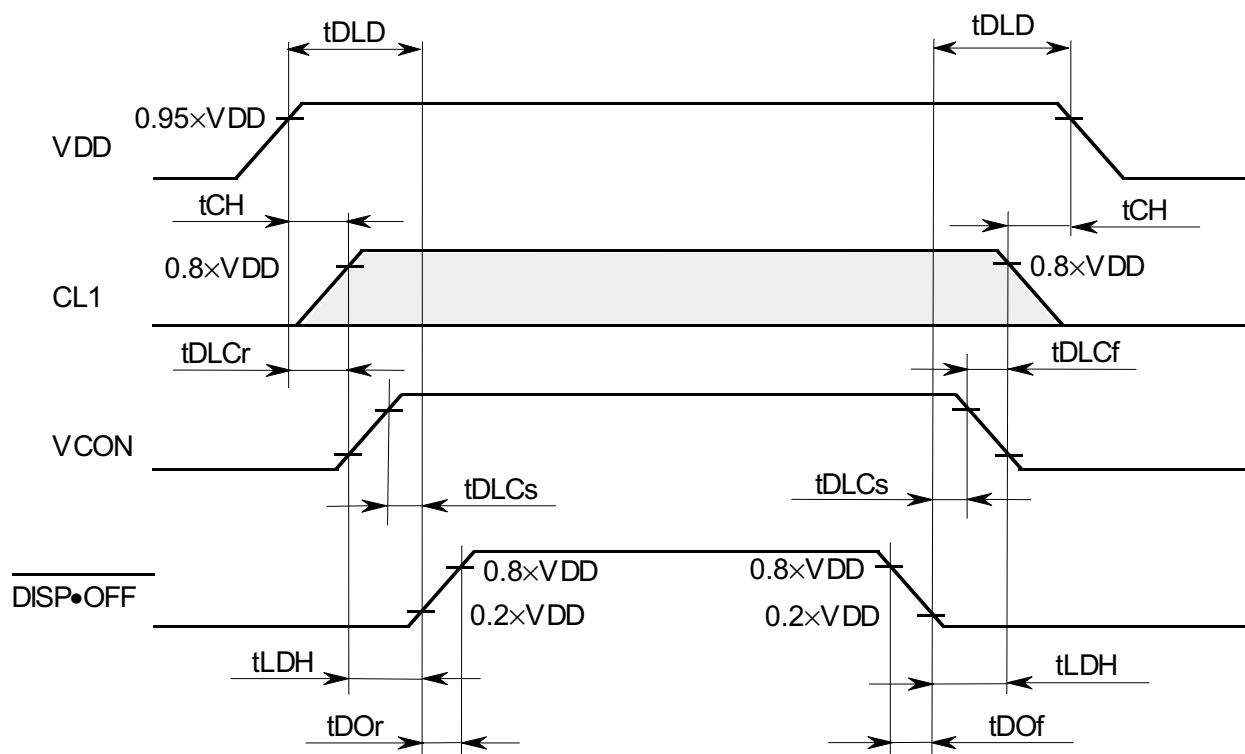

SYMBOL	MIN	MAX	UNIT	COMMENT
t_{DLD}	200	-	ms	—
t_{CH}	0	-	ms	
t_{LDH}	20	-	ms	
t_{DOr}	-	100	ns	
t_{DOf}	-	100	ns	
t_{DLcR}	0	-	ms	
t_{DLcF}	0	-	ms	
t_{DLcS}	20	-	ms	

(Note 1) Please keep the specified sequence. Using other than the recommended sequence may cause permanent damage to the LCD panel.

(Note 2) Please use $\overline{\text{DISP}}\bullet\text{OFF}$ function.

Switching by other than the $\overline{\text{DISP}}\bullet\text{OFF}$ function may cause display deterioration.

8.4 POWER SUPPLY FOR LCM (Example)

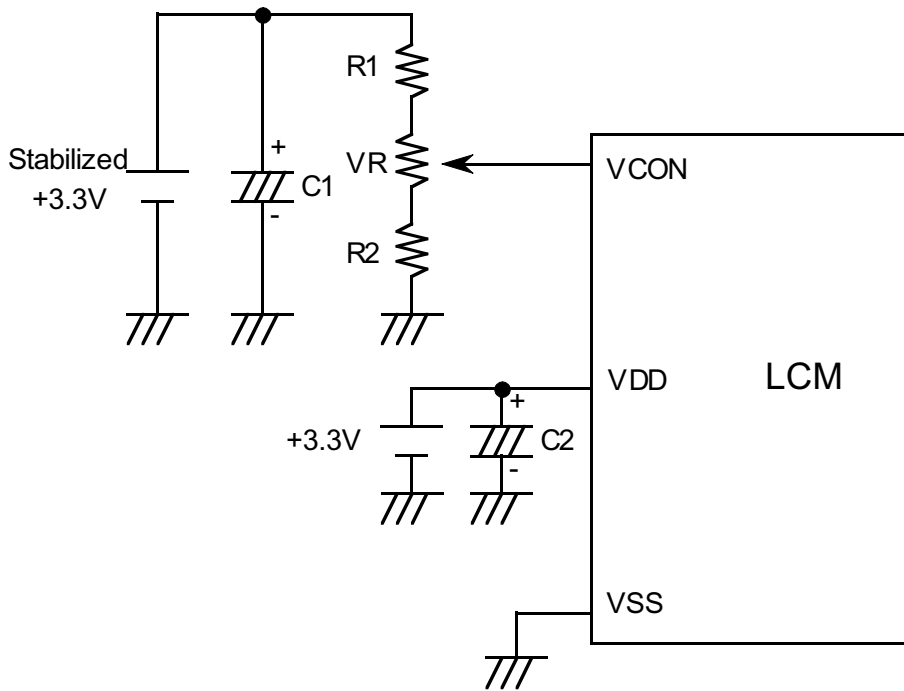

Note 1 : $R1+VR+R2 \leq 10k\Omega$

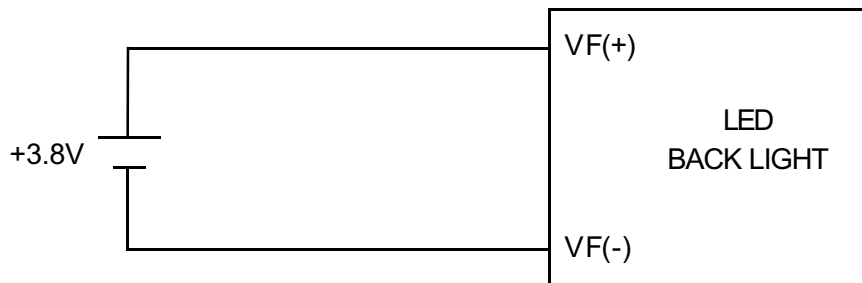

8.5 INPUT DATA ALLOCATION TABLE

Data Signal	D 7	D 6	D 5	D 4	D 3	D 2	D 1	D 0	D 7	D 6	D 5	D 4	----	D 4	D 3	D 2	D 1	D 0
X \ Y	1	2	3	4	5	6	7	8	9	10	11	12	----	9 5 6	9 5 7	9 5 8	9 5 9	9 6 0
	1	R	G	B	R	G	B	R	G	B	R	G	B	----	G	B	R	G
2	R	G	B	R	G	B	R	G	B	R	G	B	----	G	B	R	G	B
3	R	G	B	R	G	B	R	G	B	R	G	B	----	G	B	R	G	B
4	R	G	B	R	G	B	R	G	B	R	G	B	----	G	B	R	G	B
5	R	G	B	R	G	B	R	G	B	R	G	B	----	G	B	R	G	B
⋮	⋮	⋮	⋮	⋮	⋮	⋮	⋮	⋮	⋮	⋮	⋮	⋮		⋮	⋮	⋮	⋮	⋮
138	R	G	B	R	G	B	R	G	B	R	G	B	----	G	B	R	G	B
139	R	G	B	R	G	B	R	G	B	R	G	B	----	G	B	R	G	B
140	R	G	B	R	G	B	R	G	B	R	G	B	----	G	B	R	G	B
141	R	G	B	R	G	B	R	G	B	R	G	B	----	G	B	R	G	B
142	R	G	B	R	G	B	R	G	B	R	G	B	----	G	B	R	G	B
143	R	G	B	R	G	B	R	G	B	R	G	B	----	G	B	R	G	B
144	R	G	B	R	G	B	R	G	B	R	G	B	----	G	B	R	G	B
145	R	G	B	R	G	B	R	G	B	R	G	B	----	G	B	R	G	B
⋮	⋮	⋮	⋮	⋮	⋮	⋮	⋮	⋮	⋮	⋮	⋮	⋮		⋮	⋮	⋮	⋮	⋮
238	R	G	B	R	G	B	R	G	B	R	G	B	----	G	B	R	G	B
239	R	G	B	R	G	B	R	G	B	R	G	B	----	G	B	R	G	B
240	R	G	B	R	G	B	R	G	B	R	G	B	----	G	B	R	G	B

R : RED
 G : GREEN
 B : BLUE

8.6 INTERNAL PIN CONNECTION

CN1 JST : 26FLZ-RSM1-TB (Suitable FPC t0.3±0.03mm, 0.5±0.03mm pitch)

PIN No.	SIGNAL	LEVEL	FUNCTION
1	VF(+)	-	Back Light
2	VF(-)	-	Back Light
3	Y1	-	Analog Signal Touch Panel
4	X1	-	Analog Signal Touch Panel
5	Y2	-	Analog Signal Touch Panel
6	X2	-	Analog Signal Touch Panel
7	VSS	-	GND
8	VCON	-	Contrast Adjustment Voltage
9	VDD	-	Power Supply for Logic
10	$\overline{\text{DISP}}\bullet\text{OFF}$	H / L	H : ON / L : OFF
11	D7	H / L	Display Data
12	D6		
13	D5		
14	D4		
15	VSS	-	GND
16	D3	H / L	Display Data
17	D2		
18	D1		
19	D0		
20	VSS	-	GND
21	VDD	-	Power Supply for Logic
22	CL2	H → L	Data Shift
23	VSS	-	GND
24	CL1	H → L	Data Latch
25	VSS	-	GND
26	FLM	H	First Line Marker

9. DIMENSIONAL OUTLINE

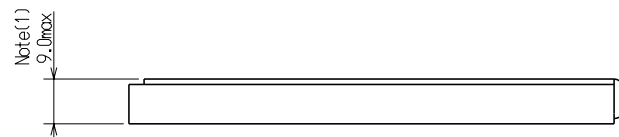
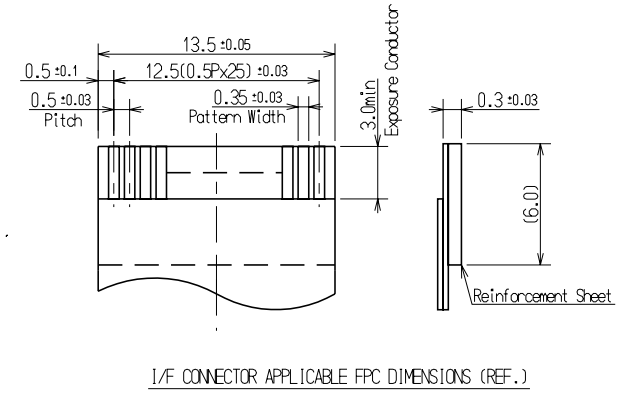
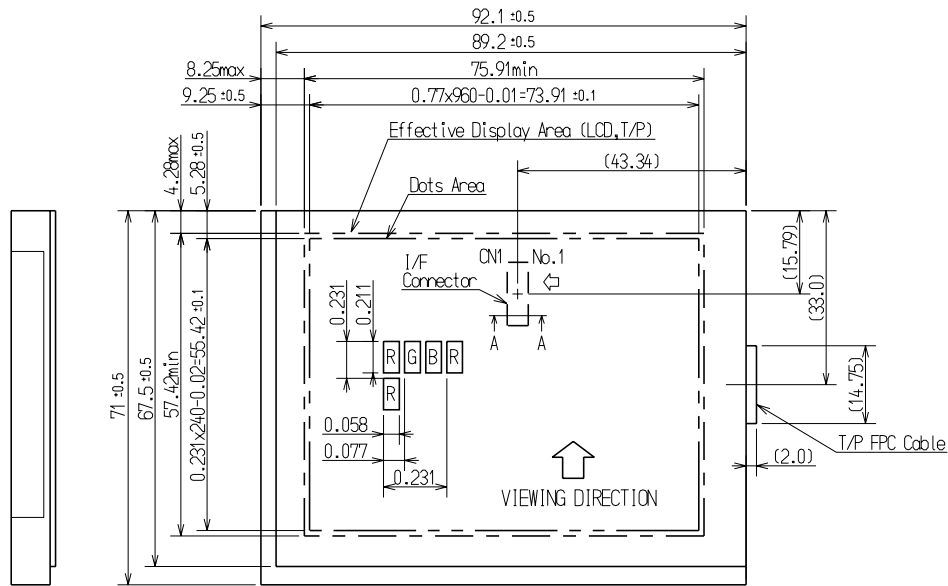

Note(1) Measurement should be done under pressure of 9.8×10^4 Pa at the measurement point.

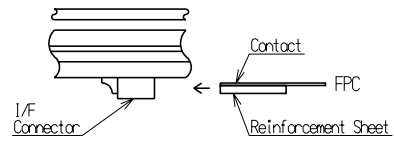

Detail of A-A

10. APPEARANCE STANDARD

10.1 APPEARANCE INSPECTION CONDITION

Visual inspection should be done under the following condition.

- (1) The inspection should be done in a dark room.
- (2) The CFL should be lighted with the prescribed inverter.
- (3) The distance between eyes of an inspector and the LCD Module is 25cm.
- (4) The viewing zone is shown in the figure.

Viewing angle $\leq 25^\circ$

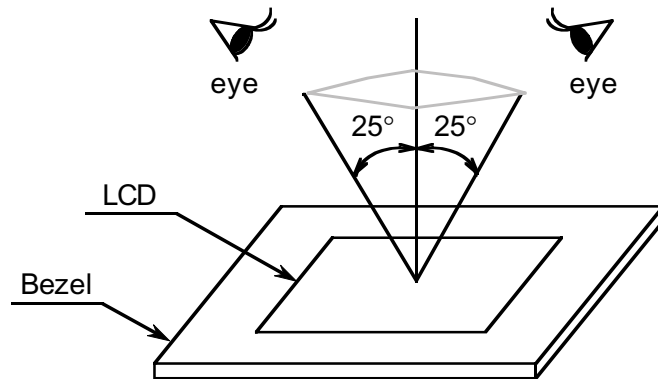

10.2 DEFINITION OF ZONE

A zone : The effective display area specified at page 9-1/1 of this document.

B zone : Area between the window of bezel line and the effective display area (A zone) line specified at page 9-1/1 of this document.

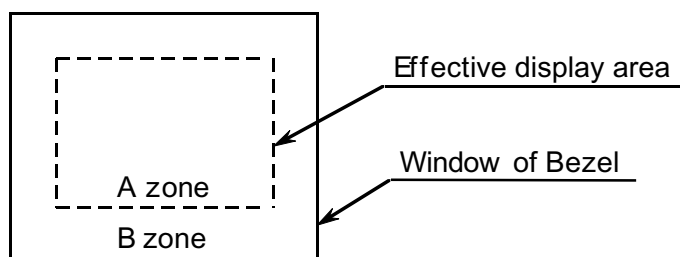

10.3 APPEARANCE SPECIFICATION

(1) LCD APPEARANCE

*) If the problem related to this section occurs about this item, the responsible persons of both party (Customer and HITACHI) will discuss the matter detail.

No.	ITEM	CRITERIA		APPLIED ZONE	
L	Scratches	Distinguished one is not acceptable (To be judged by HITACHI STANDARD)		A	
	Dent	Same as above		A	
	Wrinkles in Polarizer	Same as above		A	
	Bubbles	Average diameter D (mm)	Maximum acceptable number		A
		$D \leq 0.2$	ignored		
$0.2 < D \leq 0.3$		12			
$0.3 < D \leq 0.5$		3			
	$0.5 < D$	none			
C D	Stains, Foreign materials Dark spot	Filamentous (Line shape)		A	
		Length L (mm)	Width W (mm)		Maximum acceptable number
		$L \leq 2.0$	$W \leq 0.03$		ignored
		$L \leq 3.0$	$0.03 < W \leq 0.05$		6
		$L \leq 2.5$	$0.05 < W \leq 0.1$		1
	Round (Dot shape)		A		
	Average diameter D (mm)	Maximum acceptable number		Minimum space	
	$D < 0.2$	ignored		—	
	$0.2 \leq D < 0.3$	10		10 mm	
	$0.3 \leq D < 0.4$	5		30 mm	
$0.4 \leq D$	none	—			
	The total number	Filamentous + Round = 10			
	Those wiped out easily are acceptable				
Color tone	To be judged by HITACHI STANDARD		A		
Color uniformity	Same as above		A		

No.	ITEM	CRITERIA				APPLIED ZONE			
L	Contrast irregularity (Spot)	Average diameter D (mm)	Contrast	Maximum acceptable number	Minimum space	A			
		$D \leq 0.25$					To be judged by HITACHI STANDARD	ignored	—
		$0.25 < D \leq 0.35$						10	20mm
		$0.35 < D \leq 0.5$						4	20mm
		$0.5 < D \leq 0.7$						3	50mm
C	$0.7 < D$	none	—						
D	Contrast irregularity (Line) (A pair of scratches)	Width W (mm)	Length L (mm)	Maximum acceptable number	Minimum space	A			
		$W \leq 0.25$	$L \leq 1.2$	2	20mm				
		$W \leq 0.2$	$L \leq 1.5$	3	20mm				
		$W \leq 0.15$	$L \leq 2.0$	3	20mm				
		$W \leq 0.1$	$L \leq 3.0$	4	20mm				
		The w hole number		6					
	Rubbing Scratch	To be judged by HITACHI STANDARD				—			

(2) LED BACKLIGHT APPEARANCE

No.	ITEM	CRITERIA			APPLIED ZONE
L E D	Dark spots White spots Foreign materials (Spot)	Average diameter D (mm)		Maximum Acceptable number	A
		$D \leq 0.4$		ignored	
		$0.4 < D$		none	
B A C K	Foreign materials (Line)	Width W (mm)	Length L (mm)	Maximum acceptable number	A
		$W \leq 0.2$	$L \leq 2.5$	1	
			$2.5 < L$	none	
$0.2 < W$	—	none			
L I G H T	Scratches	Width W (mm)	Length L (mm)	Maximum acceptable number	A
		$W \leq 0.1$	—	ignored	
		$0.1 < W \leq 0.2$	$L \leq 11.0$	1	
			$11.0 < L$	none	
$0.2 < W$	—	none			

(3) TOUCH PANEL APPEARANCE

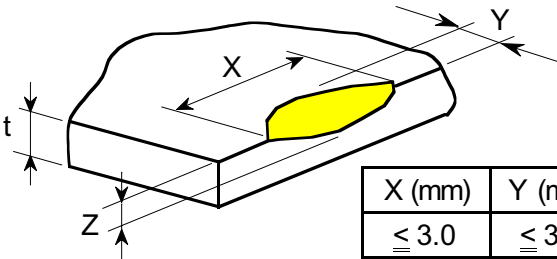
No.	ITEM	CRITERIA		APPLIED ZONE												
T O U C H P A N E L	Foreign material (Black or White spots)	Average diameter D (mm)	Criteria	A												
		$D \leq 0.2$	ignored													
		$0.2 < D \leq 0.4$	1 (Note 3)													
		$0.4 < D$	none													
	Foreign material (Line)	Length L (mm), Width W (mm)	Criteria	A												
		$L \leq 3.0$ and $W \leq 0.05$	ignored													
		$L \leq 3.0$ and $0.05 < W \leq 0.1$	1 (Note 3)													
		$L > 3.0$ and $0.1 < W$	none													
	Uncleanliness	No conspicuous dirt		A												
	Crack in glass plate	No cracks are allowed		A												
	Scratch	Length L (mm), Width W (mm)	Criteria	A												
		$L \leq 5$ and $W \leq 0.03$	ignored													
		$5 < L \leq 15$ and $W \leq 0.05$ or $L \leq 15$ and $0.03 < W \leq 0.05$	1													
		$L > 15$ and $0.05 < W$	none													
Chip and Crack	General chip X : Width direction to ridge line Y : Length direction to ridge line Z : Thickness direction to ridge line t : Glass thickness		-													
		 <table border="1" data-bbox="957 1288 1348 1467"> <thead> <tr> <th>X (mm)</th> <th>Y (mm)</th> <th>Z</th> </tr> </thead> <tbody> <tr> <td>≤ 3.0</td> <td>≤ 3.0</td> <td>$\leq t$</td> </tr> <tr> <td>≤ 5.0</td> <td>≤ 1.0</td> <td>$\leq t$</td> </tr> <tr> <td>≤ 5.0</td> <td>≤ 3.0</td> <td>$\leq 2/3t$</td> </tr> </tbody> </table>		X (mm)	Y (mm)	Z	≤ 3.0	≤ 3.0	$\leq t$	≤ 5.0	≤ 1.0	$\leq t$	≤ 5.0	≤ 3.0	$\leq 2/3t$	
X (mm)	Y (mm)	Z														
≤ 3.0	≤ 3.0	$\leq t$														
≤ 5.0	≤ 1.0	$\leq t$														
≤ 5.0	≤ 3.0	$\leq 2/3t$														

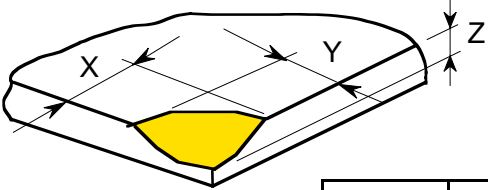
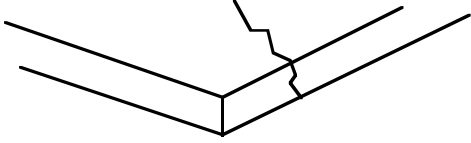
No.	ITEM	CRITERIA	APPLIED ZONE									
T O U C H P A N E L	Chip and Crack	Corner chip t : Glass thickness  <table border="1" data-bbox="970 510 1359 645"> <thead> <tr> <th>X (mm)</th> <th>Y (mm)</th> <th>Z</th> </tr> </thead> <tbody> <tr> <td>≤ 3.0</td> <td>≤ 3.0</td> <td>$\leq t$</td> </tr> <tr> <td>≤ 5.0</td> <td>≤ 3.0</td> <td>$\leq 2/3t$</td> </tr> </tbody> </table>	X (mm)	Y (mm)	Z	≤ 3.0	≤ 3.0	$\leq t$	≤ 5.0	≤ 3.0	$\leq 2/3t$	-
		X (mm)	Y (mm)	Z								
≤ 3.0	≤ 3.0	$\leq t$										
≤ 5.0	≤ 3.0	$\leq 2/3t$										
Bad crack (possibly expanding) ALL shall be rejected. 												

Note (1) Definition of Average diameter (D)

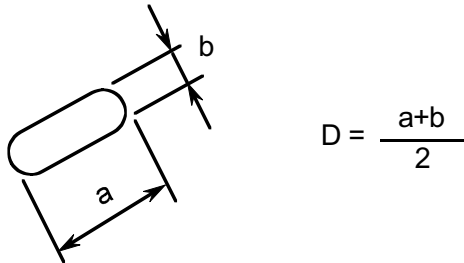

Note (2) Definition of Length (L) and Width (W)

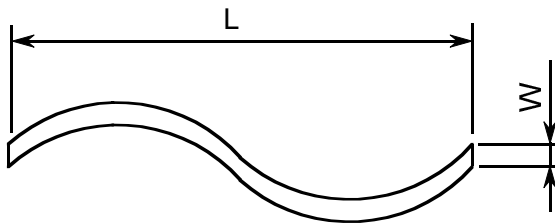

Note (3) Within $\phi 4.0$: foreign matter at center of the circle.

11. PRECAUTION IN DESIGN

11.1 MOUNTING PRECAUTION

(1) When assembling the touch panel and your case, please refer to the figure below .

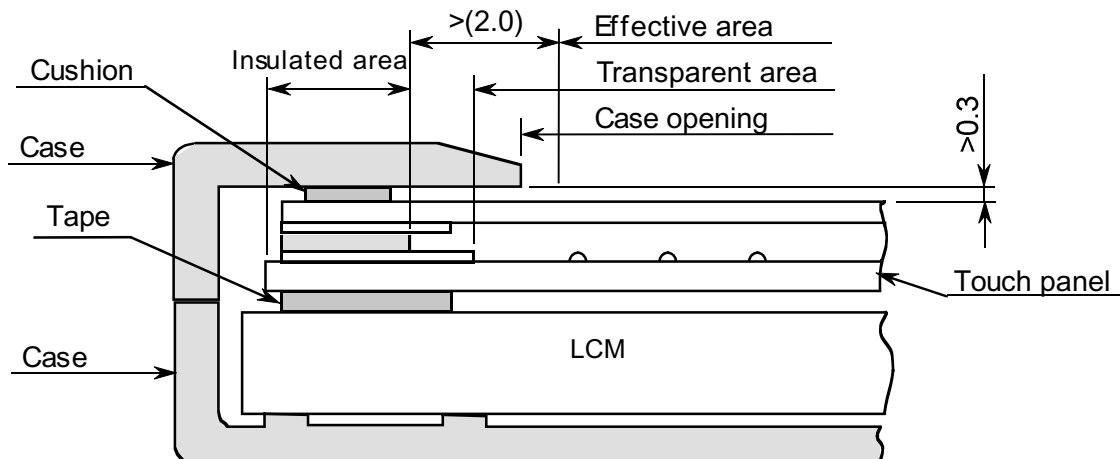

- (2) The clearance between the touch panel and the case shall be designed so that the case edge never presses the input screen when it is deformed by heat or other causes.
- (3) The case shall be designed not to touch the tail portion (FPC for touch panel).
- (4) The boundary space between the effective area and the insulated area is unstable. Touching this area may affect the operation of the touch panel. The case must be designed so that it does not touch the boundary space.

11.2 PRECAUTIONS AGAINST ELECTROSTATIC DISCHARGE

As this module contains C-MOS LSIs, it is not strong against electrostatic discharge. Make certain that the operator's body is connected to the ground through a wrist band etc. And don't touch I/F pins directly.

11.3 POWER ON SEQUENCE

Input signals should not be applied to LCD module before power supply voltage is applied and reaches to specified voltage ($3.0 \pm 0.15V$).

If the above sequence is not kept, C-MOS LSIs of LCD module may be damaged due to latch up phenomenon.

11.4 HANDLING PRECAUTIONS

- (1) Since the polarizer on the top, and the aluminum plate on the bottom tend to be easily damaged, they should be handled with full care so as not to get them touched, pushed or rubbed by a piece of glass, tweezers and anything else which are harder than a pencil lead 3H.

Displays, Hitachi, Ltd.	Date	Nov. 27, 2000	Sh. No.	3284PS 2711 - SC09Q002-AZA - 2	Page	11-1/3
----------------------------	------	---------------	------------	--------------------------------	------	--------

- (2) As the adhesives used for adhering upper/lower polarizers and aluminum plate are made of organic substances which will be deteriorated by a chemical reaction with such chemicals as acetone, toluene, ethanol and isopropylalcohol. The following solvents are recommended for use : Normal hexane
Please contact us when it is necessary for you to use chemicals other than the above.
- (3) Lightly wipe to clean the dirty surface with absorbent cotton or other soft material like chamois, soaked in the recommended chemicals without scrubbing it hardly.
Always wipe the surface horizontally or vertically. Never give a wipe in a circle. To prevent the display surface from damage and keep the appearance in good state, it is sufficient, in general, to wipe it with absorbent cotton.
- (4) Immediately wipe off saliva or water drop attached on the display area because it may cause deformation or faded color.
- (5) Foggy dew deposited on the surface may cause a damage, stain or dirt to the polarizer.
When you need to take out the LCD module from some place at low temperature for test, etc. It is required to be warmed them up to be temperature higher than room temperature before taking them out.
- (6) Touching the display area or V/F pins with bare hands or contaminating them are prohibited, because the stain on the display area and poor insulation between terminals are often caused by being touched with bare hands.
(Some cosmetics are detrimental to polarizers.)
- (7) In general, the glass is fragile so that it, especially on its periphery, tends to be cracked or chipped in handling. Please do not give the LCD module sharp shocks caused by falling etc.
- (8) Maximum pressure to the surface must be less than 1.96×10^4 Pa .
And if the pressure area is less than 1cm^2 , maximum pressure must be less than 1.96N .
- (9) Since the metal width is narrow on these locations (see page 9-1/1), please be careful with handling.
- (10) Top sheets shall be cleaned gently using a soft cloth such as those used for glasses.
Hard wiping accumulated dust will leave scars on the surface even using a cloth.

11.5 OPERATION PRECAUTION

- (1) Using a LCM module beyond its maximum ratings may result in its permanent destruction. LCM module's should usually be used under recommended operating conditions shown in chapter 5. Exceeding any of these conditions may adversely affect its reliability.

Displays, Hitachi, Ltd.	Date	Nov. 27, 2000	Sh. No.	3284PS 2711 - SC09Q002-AZA - 2	Page	11-2/3
----------------------------	------	---------------	------------	--------------------------------	------	--------

- (2) Response time will be extremely delayed at lower temperature than the specified operating temperature range and on the other hand LCD's show s dark blue color at higher temperature. However those phenomena do not mean defects of the LCD module. Those phenomena will disappear in the specified operating temperature range.
- (3) If the display area is pushed hard during operation, some display patterns will be abnormally displayed.
- (4) A slight dew depositing on terminals may cause electrochemical reaction which leads to terminal open circuit. Please operate the LCD module under the relative condition of 40°C 85%RH.
- (5) Resistance range : Your controller shall be set up to allow the resistance range of touch panel specified in our CAS.
- (6) Pointed position of touch panel may shift owing to a change in resistance of touch panel depending on the operation condition. To compensate this shift, the set shall be given a calibration function.
- (7) Input shall be made with a stylus pen (polyacetal, R0.8). Chances are very high that use of a metal piece including a ball point pen or sharp edge will impair accuracy.
- (8) The touch panel is an auxiliary input device. The system shall be designed to have other input device.

11.6 STORAGE

In case of storing LCD module for a long period of time (for instance, for years) for the purpose of replacement use, the following precautions necessary.

- (1) Store the LCD modules in a dark place ; do not expose them to sunlight or ultraviolet rays.
- (2) Keep the temperature between 10°C and 35°C at normal humidity.
- (3) Store the LCD modules in the container which is used for shipping from us.
- (4) No articles shall be left on the surface over an extended period of time.

11.7 SAFETY

The LCD modules include Cold Cathode Fluorescent Lamp (CFL). CFL contains a small amount of mercury. Please follow local ordinances or regulations for disposal.

Wear finger cots or gloves whenever handling or assembling a touch panel because its glass edges are sharp.

Displays, Hitachi, Ltd.	Date	Nov. 27, 2000	Sh. No.	3284PS 2711 - SC09Q002-AZA - 2	Page	11-3/3
----------------------------	------	---------------	------------	--------------------------------	------	--------

12. DESIGNATION OF LOT MARK

12.1 LOT MARK

Lot mark is consisted of 4 digits for production lot and 6 or 7 digits for production control.

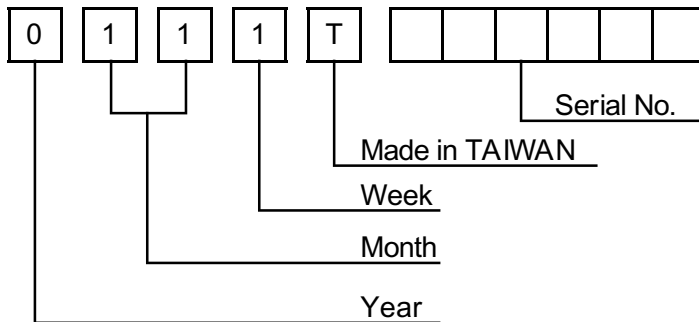

Year	Figure in lot mark
2000	0
2001	1
2002	2
2003	3

Month	Figure in lot mark	Month	Figure in lot mark
Jan.	01	July	07
Feb.	02	Aug.	08
Mar.	03	Sep.	09
Apr.	04	Oct.	10
May	05	Nov.	11
June	06	Dec.	12

Week (day in Calender)	Figure in lot mark
1~7	1
8~14	2
15~21	3
22~28	4
29~31	5

Location of lot mark : On the back side of LCM

0111T*****

12.2 REVISION

REV No.	ITEM	LOT No.	PRODUCTION CONTROL No.
A	Segment LCD Driver : BD66134U		00001~
B	Segment LCD Driver : WFP-7102		00001~

13. PRECAUTION FOR USE

- (1) A limit sample should be provided by the both parties on an occasion when the both parties agree to its necessity.
Judgment by a limit sample shall take effect after the limit sample has been established and confirmed by the both parties.
- (2) On the following occasions, the handling of the problem should be decided through discussion and agreement between responsible persons of the both parties.
 - (1) When a question is arisen in the specifications.
 - (2) When a new problem is arisen which is not specified in the specifications.
 - (3) When an inspection specification change or operating condition change by customer is reported to HITACHI, and some problem is arisen in the specification due to the change.
 - (4) When a new problem is arisen at the customer's operating set for sample evaluation in the customer site.
- (3) Regarding the treatment for maintenance and repairing, both parties will discuss it in six months later after latest delivery of this product.

The precaution that should be observed when handling LCM have been explained above. If any points are unclear or if you have any requests, please contact Hitachi.

Displays, Hitachi, Ltd.	Date	Nov. 27, 2000	Sh. No.	3284PS 2713 - SC09Q002-AZA - 2	Page	13-1/1
----------------------------	------	---------------	------------	--------------------------------	------	--------