

2 to 4 Phase PWM Extender for Multiphase Synchronous Buck Converter

General Description

The uP1911R is a high precision sequence array, which is intended for operation phase number extension in multiphase synchronous-rectified buck converter. It consists of three individual sequence circuits to support up to 2 to 4 phase extension application. This part has 4 PWM outputs for external MOSFET drivers, and 4 ISEN inputs. With this phase extender, a 2-phase buck PWM controller is able to control a 4-phase synchronous buck regulator. This device has an internal LDO that regulates 12V input to a 5.2V output as the power supply of control logic. Designed with 12V CMOS process, the uP1911R provides high switching speed and low power dissipation. The uP1911R is available in WQFN3x3 - 16L package.

Ordering Information

Order Number	Package	Top Marking
uP1911RQDD	WQFN3x3 -16L	uP1911R

Note: uPI products are compatible with the current IPC/ JEDEC J-STD-020 requirement. They are halogen-free, RoHS compliant and 100% matte tin (Sn) plating that are suitable for use in SnPb or Pb-free soldering processes.

Features

- ❑ 5V/12V Supply Voltage
- ❑ Integrated 5.2V LDO Regulator for 12V Input
- ❑ Support 1 to 2, 2 to 4 Phase Extension
- ❑ Low Power Dissipation
- ❑ Low Charge Injection
- ❑ Near Zero Switching Time
- ❑ RoHS Compliant and Halogen Free
- ❑ WQFN3x3 - 16L Package

Applications

- ❑ Desktop Computer
- ❑ Motherboards

Pin Configuration

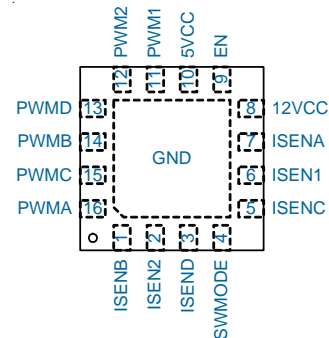

Typical Application Circuit

Low-Side MOSEFET R_{ds(on)} Current Sense

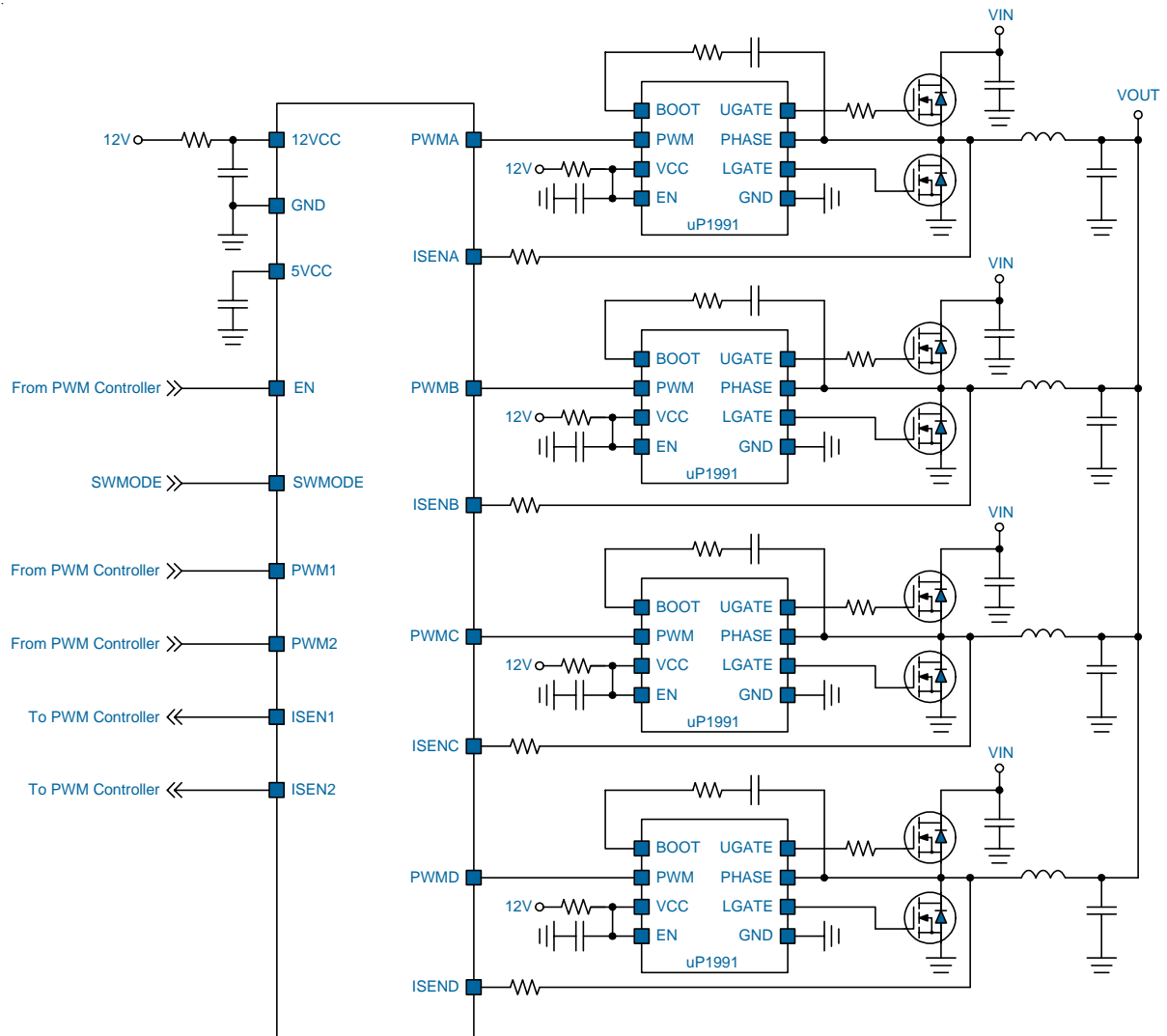

Typical Application Circuit

Inductor DCR Current Sense

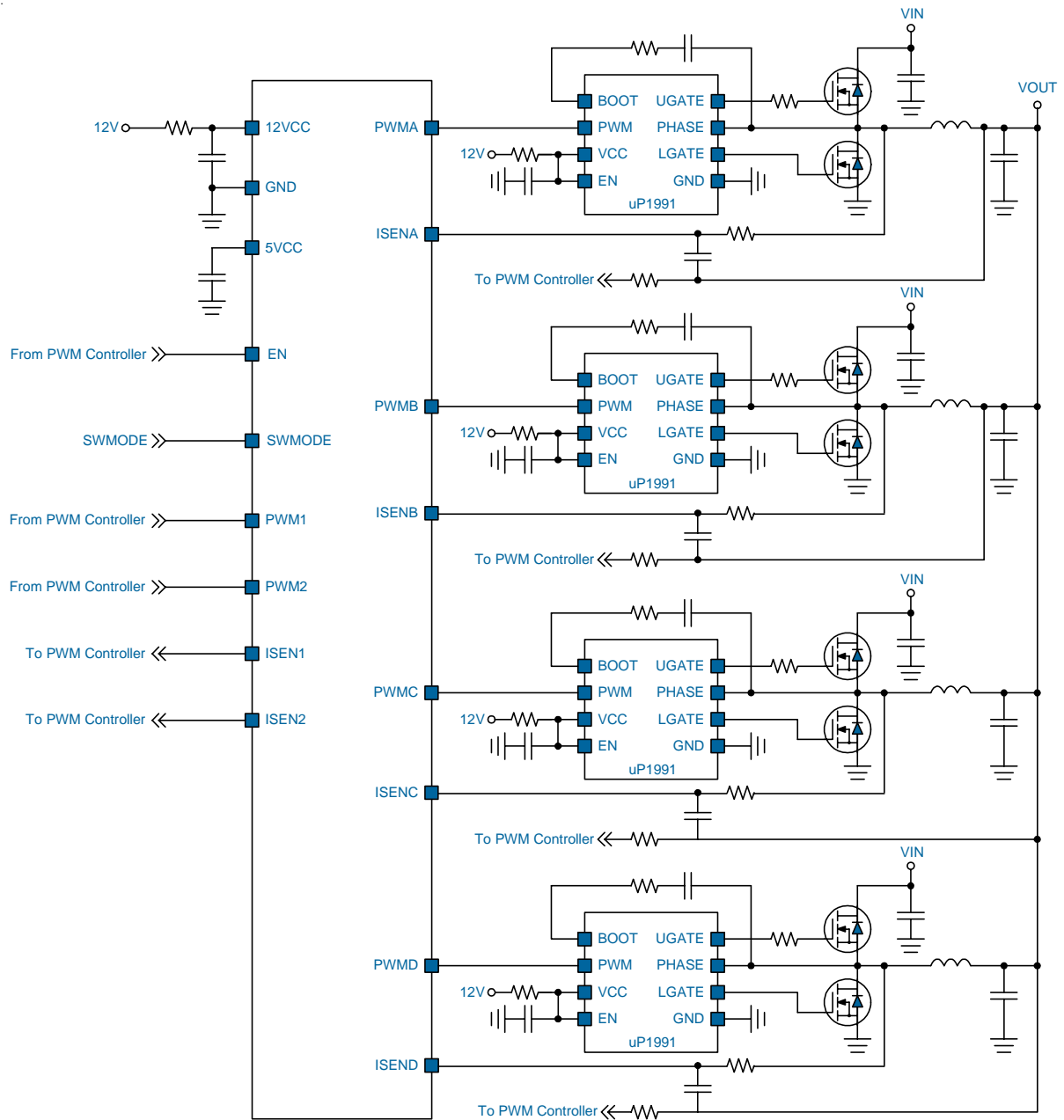

Functional Pin Description

No.	Pin Name	Pin Function
1	ISENB	ISENB Input. Connect this pin to phase 2 switching node via a resistor.
2	ISEN2	ISEN2 Output. Connect this pin to PWM controller ISEN2 pin.
3	ISEND	ISEND Input. Connect this pin to phase 4 switching node via a resistor.
4	SWMODE	SWMODE Input. This pin controls the internal analog switch on-state connection timing of ISENA(B) or ISENC(D) to ISEN1(2). Connect this pin to GND at the default, and it can be connected to 5VCC for another switching timing. See ISEN Connection Sequence section for detail.
5	ISENC	ISENC Input. Connect this pin to phase 3 switching node via a resistor.
6	ISEN1	ISEN1 Output. Connect this pin to PWM controller ISEN1 pin.
7	ISENA	ISENA Input. Connect this pin to phase 1 switching node via a resistor.
8	12VCC	12V Supply Voltage. Connect a minimum of 1uF ceramic capacitor from this pin to ground.
9	EN	PWM Output Disable. This pin disables normal operation and forces all PWM outputs off when it is pulled low.
10	5VCC	LDO Output Voltage. This pin is the output of internal LDO that regulates 12VCC to a 5.2V output. Connect a minimum of 1uF ceramic capacitor from this pin to ground. For single 5V input operation, connect this pin together with 12VCC to 5V.
11	PWM1	PWM1 Input. Connect this pin to the PWM controller PWM1 output.
12	PWM2	PWM2 Input. Connect this pin to the PWM controller PWM2 output.
13	PWMD	PWMD Output. Connect this pin to the input of external MOSFET driver for phase 4.
14	PWMB	PWMB Output. Connect this pin to the input of external MOSFET driver for phase 2.
15	PWMC	PWMC Output. Connect this pin to the input of external MOSFET driver for phase 3.
16	PWMA	PWMA Output. Connect this pin to the input of external MOSFET driver for phase 1.
	Exposed Pad	Ground. This pin is the signal ground of the IC. Tie this pin to the ground island/plane through the lowest impedance connection available.

Functional Block Diagram

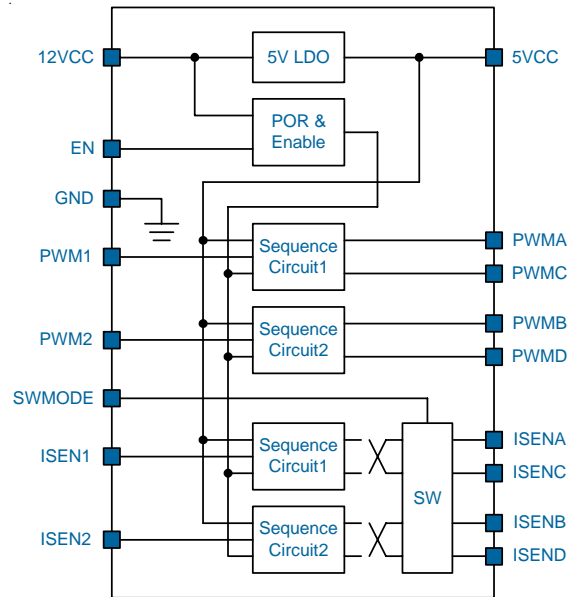

Supply Voltage

The uP1911R works with a single 12V or 5V supply input voltage. Figure 1 and Figure 2 show the ways of being powered from 12V and 5V, respectively. For single 12V input operation, connect 12VCC to a 12V voltage source, and bypass this pin to ground with at least 1uF ceramic capacitor for noise decoupling. An internal LDO regulator regulates this 12V input to a 5.2V at 5VCC pin as the power for the whole chip. Connect 1uF ceramic capacitor from 5VCC to ground for noise decoupling. For single 5V input operation, connect both 12VCC and 5VCC to a 5V voltage source, and bypass 5VCC to ground with at least 1uF ceramic capacitor for noise decoupling. When the uP1911R is directly supplied from 5V, the internal LDO is inactive. The 12VCC voltage is monitored for power on reset (POR). If 12VCC voltage is higher than the POR rising threshold, the PWM outputs and ISEN sequence circuits will be enabled. The POR threshold has a hysteresis to avoid advertently shutdown.

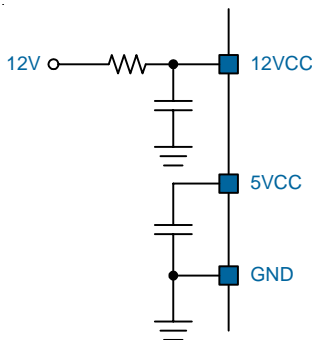

Figure 1. Single 12V Supply Input

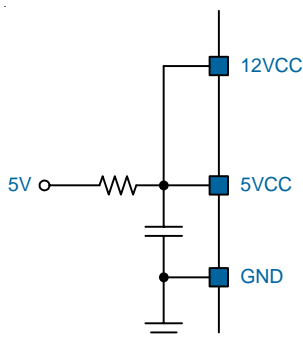

Figure 2. Single 5V Supply Input

PWM Output Sequence

The uP1911R has two individual sequence circuits to control the PWM input and output sequence. Figure 3 shows the sequence of PWM1, PWMA and PWMC. The PWM1 receives PWM signal from the voltage regulator (VR) controller and outputs the received signal to PWMA or PWMC in an alternating way. That is to say PWMA and PWMC output the received signal in turn. For 2-phase to 4-phase application, the uP1911R receives signals PWM[1,2] from VR controller and outputs them to PWM[A:D]. Therefore, the operation phase number is extended from 2 to 4, and the 2-phase PWM VR controller can be used in a 4-phase VR design. Figure 4 shows the 2-phase to 4-phase PWM extension.

For the PWM controller uses its PWM pin as a multi-function pin, a resistor will be connected from PWM pin to GND to set parameter. Note that this resistor must be greater than 15KΩ. Lower resistor value will cause incorrect PWM voltage level at the PWM pin when the PWM controller output is in tri-state (high-impedance state).

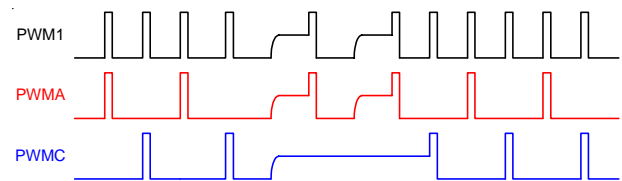

Figure 3. Sequence of PWM1, PWMA and PWMC

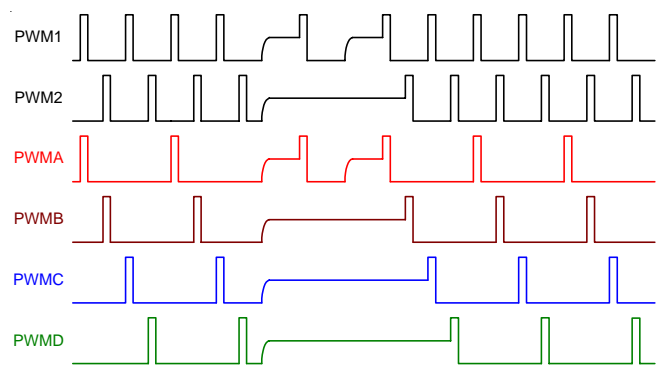

Figure 4. Sequence of PWM[1,2] and PWM[A:D]

Functional Description

Enable

Logic low of EN disables all PWM outputs and tie the EN pin to controller.

ISEN Connection Sequence

The uP1911R provides two individual sequence circuits to control the ISEN connection sequence. The ISEN connection sequence is for LGATE sensing or DCR sensing. When SWMODE connects to GND, Figure 5 shows the sequence of PWM outputs and the ISEN connection states. The on-state of the connection between ISEN1 and ISENA begins at the PWMC falling edge, and it ends at the next PWMA falling edge. The on-state of the connection between ISEN1 and ISENA allows switching node voltage signal passing from ISENA to ISEN1. The operational principle of ISEN1 to ISENC is similar as described above. The on-state of the connection between ISEN1 and ISENC begins at the PWMA falling edge, and it ends at the next PWMC falling edge.

When SWMODE connects to 5VCC, Figure 6 shows the sequence of PWM outputs and the ISEN connection states. The on-state of the connection between ISEN1 and ISENA begins at the PWMA falling edge, and it ends at the next PWMC falling edge. The on-state of the connection between ISEN1 and ISENA allows switching node voltage signal passing from ISENA to ISEN1. The operational principle of ISEN1 to ISENC is similar as described above. The on-state of the connection between ISEN1 and ISENC begins at the PWMC falling edge, and it ends at the next PWMA falling edge.

The connection between ISEN1 to ISENA and ISEN1 to ISENC changes in an alternating way. That is to say when ISEN1 to ISENA connection is ON, ISEN1 to ISENC connection is OFF, and vice versa.

There is a break-before-make delay time to ensure that ISENA and ISENC never connect to each other. ISEN2 and ISEN[B,D] works in a similar way.

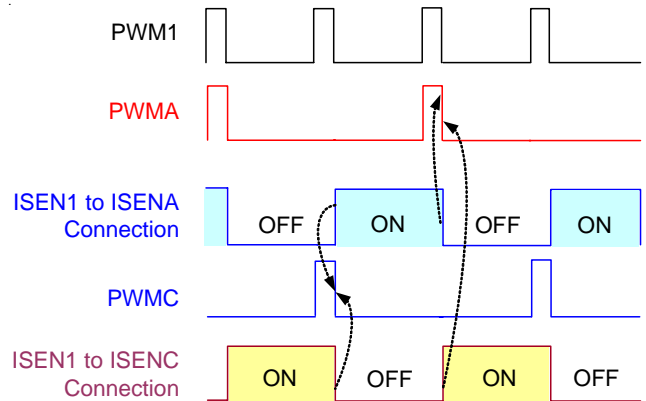

Figure 5. Sequence of PWM Outputs and ISEN Connection States

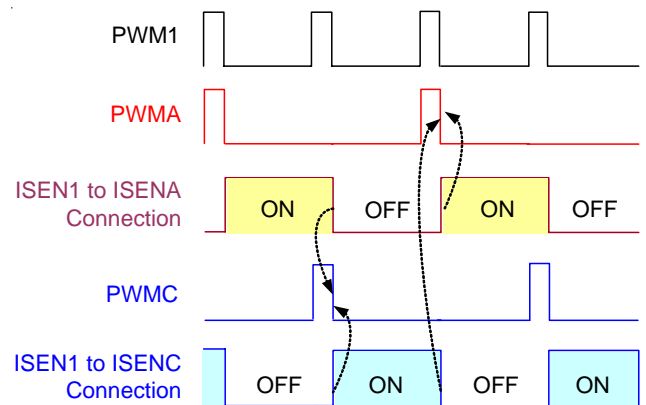

Figure 6. Sequence of PWM Outputs and ISEN Connection States

Absolute Maximum Rating

(Note 1)

Supply Input Voltage 12VCC -----	-0.3V to +15V
ISENA~D/ISEN1~2/EN/SWMODE/PWM1~2 -----	-0.3V to +7V
Storage Temperature Range -----	-65°C to +150°C
Junction Temperature -----	150°C
Lead Temperature (Soldering, 10 sec) -----	260°C
ESD Rating (Note 2)	
HBM (Human Body Mode) -----	2kV
MM (Machine Mode) -----	200V

Thermal Information

Package Thermal Resistance (Note 3)

WQFN3x3 - 16L θ_{JA} -----	68°C/W
WQFN3x3 - 16L θ_{JC} -----	6°C/W
Power Dissipation, P_D @ $T_A = 25^\circ\text{C}$	
WQFN3x3 - 16L -----	1.47W

Recommended Operation Conditions

(Note 4)

Operating Junction Temperature Range -----	-40°C to +125°C
Operating Ambient Temperature Range -----	-40°C to +85°C
Supply Input Voltage, 12VCC -----	+4.5V to +13.2V

- Note 1.** Stresses listed as the above *Absolute Maximum Ratings* may cause permanent damage to the device. These are for stress ratings. Functional operation of the device at these or any other conditions beyond those indicated in the operational sections of the specifications is not implied. Exposure to absolute maximum rating conditions for extended periods may remain possibility to affect device reliability.
- Note 2.** Devices are ESD sensitive. Handling precaution recommended.
- Note 3.** θ_{JA} is measured in the natural convection at $T_A = 25^\circ\text{C}$ on a low effective thermal conductivity test board of JEDEC 51-3 thermal measurement standard.
- Note 4.** The device is not guaranteed to function outside its operating conditions.
- Note 5.** Guaranteed by design.

Electrical Characteristics

 (Test Condition: 12VCC = 12V, T_A = 25°C, unless otherwise specified)

Parameter	Symbol	Test Conditions	Min	Typ	Max	Unit
Supply Input Voltage						
POR Threshold	12V _{CC_RTH}	PWM [A:D] outputs enabled	3.0	3.4	4.4	V
POR Hysteresis	12V _{CC_HYS}		0.1	0.3	0.46	V
Supply Input Current	I _{12VCC}		--	2.5	5.0	mA
5VCC Regulated Voltage	V _{5VCC}	12VCC = 12V	4.95	5.20	5.45	V
Analog Switch						
On Resistance	R _{ON}	ISEN[1,2] to ISEN[A:D] current = 0.5mA	100	200	300	Ω
Analog Switch Dynamic Characteristics						
Turn Off Time	T _{OFF}	R _{LOAD} = 10kΩ, C _{LOAD} = 4.7pF, V _{ISEN} = 1V (Note 5)	--	15	--	ns
Turn On Time	T _{ON}	R _{LOAD} = 10kΩ, C _{LOAD} = 4.7pF V _{ISEN} = 1V (Note 5)	--	30	--	ns
Break-Before-Make Delay	T _{DLY}	C _{LOAD} = 4.7pF (Note 5)	--	3.4	--	ns
PWM Digital Logic Gate Output Characteristic						
High-Z to High Threshold Level	V _{IH_HI-Z}	PWM[A:D], R _{LOAD} = 10kΩ to GND, and 10kΩ to 5VCC	--	2.34	2.80	V
High to High-Z Threshold Level	V _{IL_HI-Z}		1.80	2.18	--	V
Low to High-Z Threshold Level	V _{IH_L-HiZ}		--	0.83	1.20	V
High-Z to Low Threshold Level	V _{IL_HI-ZL}		0.40	0.67	--	V
Output High Voltage	V _{OH}	R _{LOAD} = 10kΩ to GND	4.5	4.9	--	V
Output Low Voltage	V _{OL}	R _{LOAD} = 10kΩ to 5VCC	--	0.1	0.4	V
Output Minimum Low Time	T _{L_MIN}	PWM[1,2] input = 3.3V to 1.5V (Note 5)	--	200	--	ns
Output High to Low Delay Time	T _{HL_DLY}		--	15	60	ns
Output Low to High Delay Time	T _{LH_DLY}		--	15	60	ns
SWMODE Voltage						
Input High	V _{SW_H}		2.2	--	--	V
Input Low	V _{SW_L}		--	--	0.8	V
Enable Voltage						
Input High	V _{EN_H}		2.2	--	--	V
Input Low	V _{EN_L}		--	--	0.8	V
Enable Delay Time						
Enable High Delay	V _{EN_H}		800	2500	5000	ns
Enable Low Delay	V _{EN_L}		100	500	1000	ns

Typical Operation Characteristics

Power ON from 12V

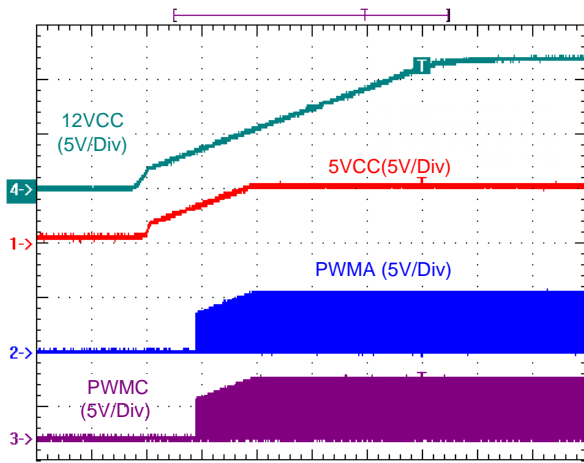

4ms/Div
 $V_{CC} = 12V$, PWM Freq. = 300kHz

Power OFF from 12V

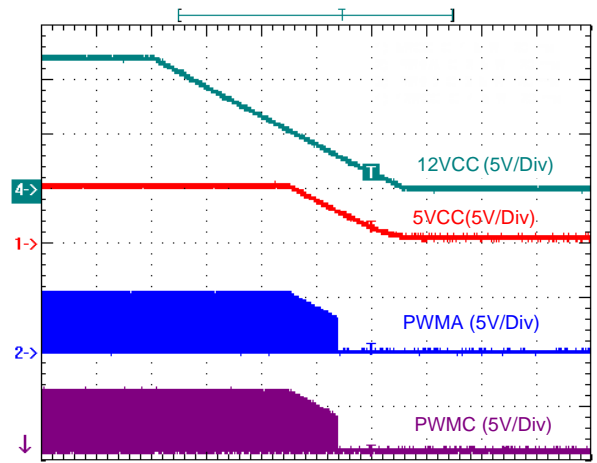

20ms/Div
 $V_{CC} = 12V$, PWM Freq. = 300kHz

Power ON from 5V

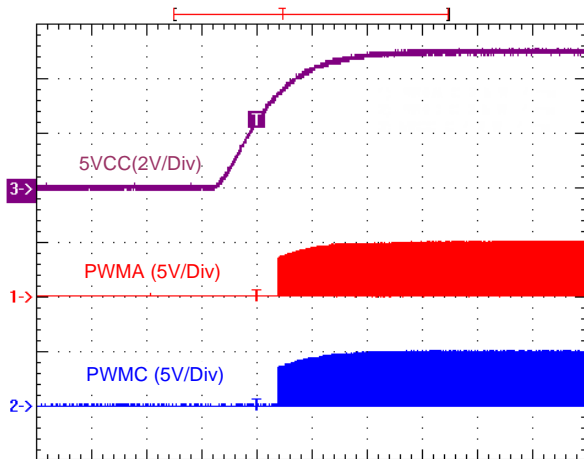

4ms/Div
 $V_{CC} = 5V$, PWM Freq. = 300kHz

Power OFF from 5V

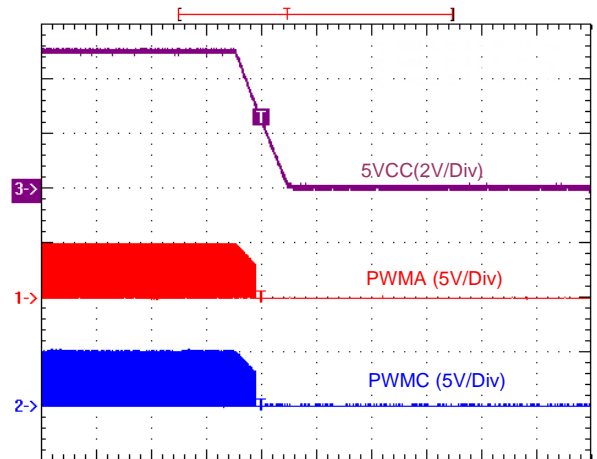

40ms/Div
 $V_{CC} = 5V$, PWM Freq. = 300kHz

PWM1 to PWMA Rising Delay

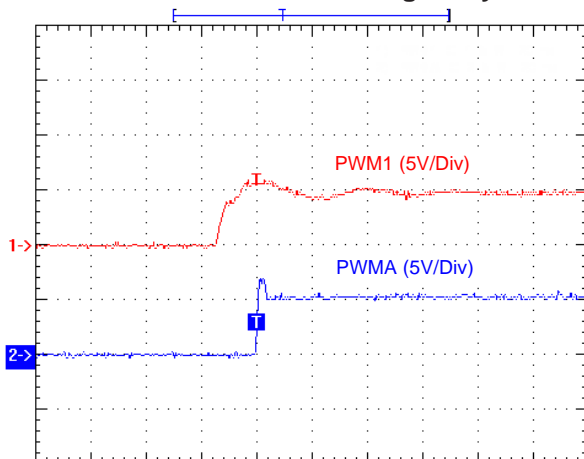

20ns/Div
 $V_{CC} = 12V$

PWM1 to PWMA Falling Delay

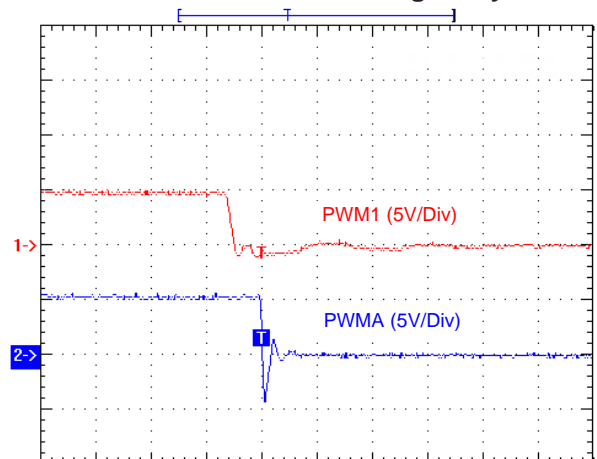

20ns/Div
 $V_{CC} = 12V$

Typical Operation Characteristics

Sequence of PWM1, PWMA and PWMC

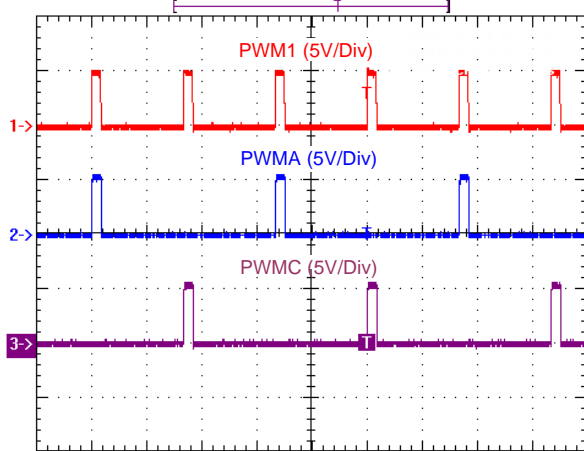

2us/Div
 $V_{CC} = 12V$, PWM Freq. = 300kHz, D = 10%

Sequence of PWMA, PWMC and ISENA, ISENC in Low Duty Cycle

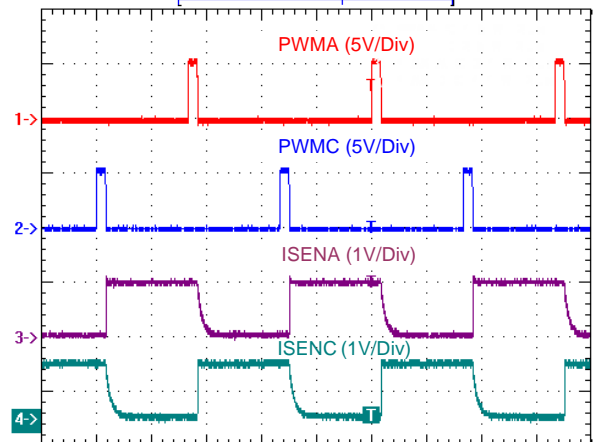

2us/Div
 $V_{CC} = 12V$, PWM Freq. = 300kHz, D = 10%,
 $V_{ISEN1} = 1V$, ISENA/C $R_{LOAD} = 10k\Omega$

Sequence of PWMA, PWMC and ISENA, ISENC in High Duty Cycle

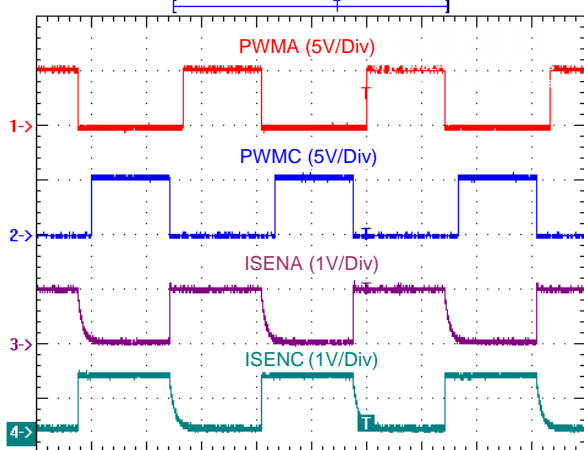

2us/Div
 $V_{CC} = 12V$, PWM Freq. = 300kHz, D = 85%,
 $V_{ISEN1} = 1V$, ISENA/C $R_{LOAD} = 10k\Omega$

Enable Low to High Delay Time

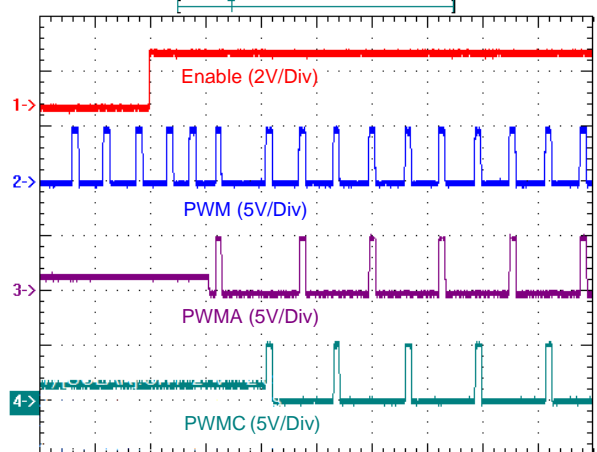

2us/Div
 $V_{CC} = 5V$, $V_{IN} = 12V$

Enable High to Low Delay Time

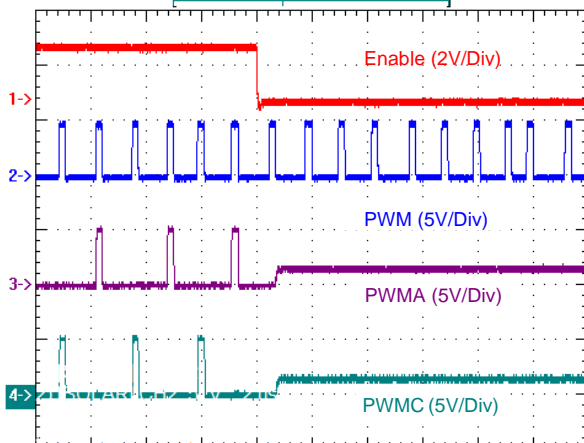

2us/Div
 $V_{CC} = 5V$, $V_{IN} = 12V$

ISEN Connection Sequence

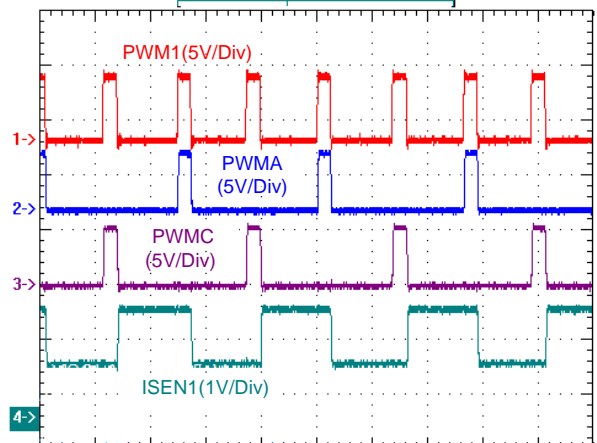

1us/Div
 $V_{CC} = 5V$, $V_{IN} = 12V$, Enable = High
 $ISENA = 1V$, $ISENC = 2V$, SWMODE = High

Typical Operation Characteristics

ISEN Connection Sequence

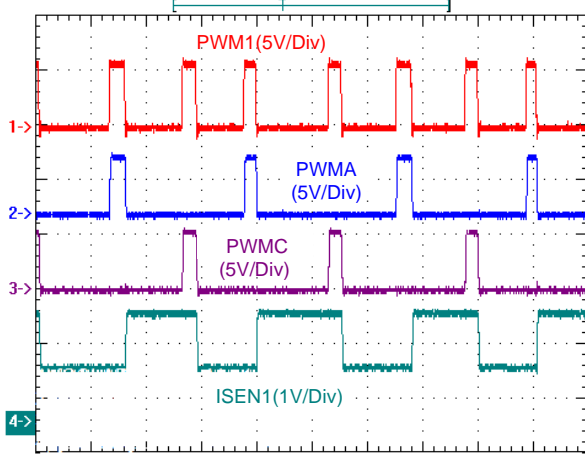

1us/Div
 $V_{CC} = 5V$, $V_{IN} = 12V$, Enable = High
 $ISENA = 1V$, $ISENC = 2V$, SWMODE = Low

5VCC Line Regulation

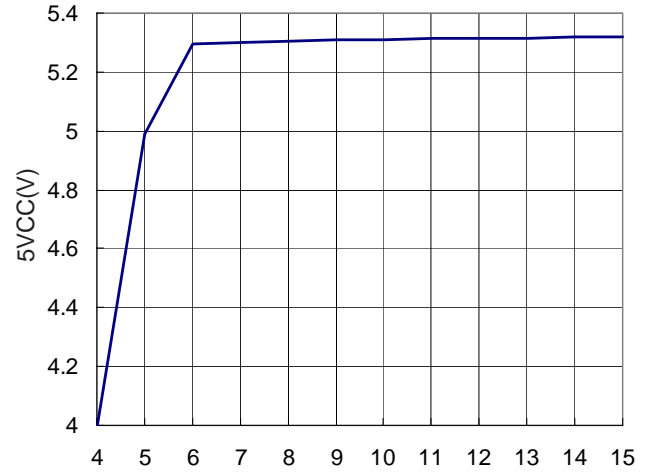

Load = 0A, $C_{5VCC} = 0.1\mu F$

5VCC Load Regulation

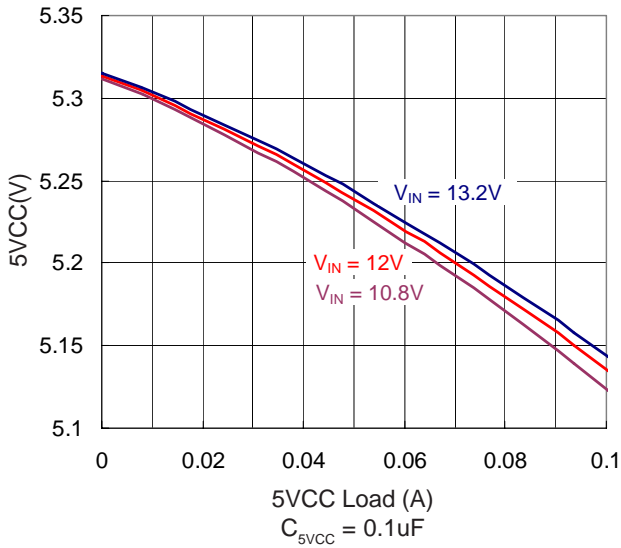

$C_{5VCC} = 0.1\mu F$

WQFN3x3-16L

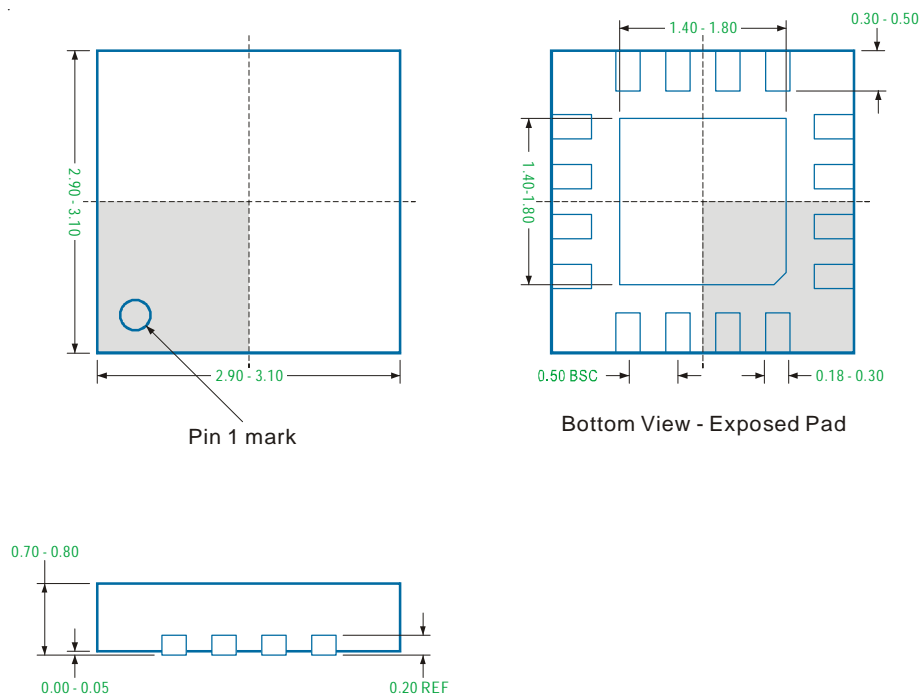

Note

1. Package Outline Unit Description:

BSC: Basic. Represents theoretical exact dimension or dimension target

MIN: Minimum dimension specified.

MAX: Maximum dimension specified.

REF: Reference. Represents dimension for reference use only. This value is not a device specification.

TYP: Typical. Provided as a general value. This value is not a device specification.

2. Dimensions in Millimeters.

3. Drawing not to scale.

4. These dimensions do not include mold flash or protrusions. Mold flash or protrusions shall not exceed 0.15mm.

Important Notice

The contents of this document are provided in connection with uPI Semiconductor Corp. (“uPI”) products. uPI makes no representations or warranties with respect to the accuracy or completeness of the contents of this publication and reserves the right to make changes to specifications and product descriptions at any time without notice.

No license, whether express, implied, arising by estoppel or otherwise, to any intellectual property rights, is granted by this publication. Except as provided in uPI’s terms and conditions of sale for such products, uPI assumes no liability whatsoever, and uPI disclaims any express or implied warranty relating to sale and/or use of uPI products, including liability or warranties relating to fitness for a particular purpose, merchantability, or infringement of any patent, copyright or other intellectual property right. uPI products are not designed, intended, authorized or warranted for use as components in systems intended for medical, life-saving, or life sustaining applications. uPI reserves the right to discontinue or make changes to its products at any time without notice.

Copyright 2019 ©, uPI Semiconductor Corp. All rights reserved.

uPI, uPI Micro Power Intellect logo, and combinations thereof, are registered trademarks of uPI Semiconductor Corp. Other product names used in this publication are for identification purposes only and may be trademarks of their respective companies.

uPI Semiconductor Corp.

9F.,No.5, Taiyuan 1st St. Zhubei City, Hsinchu, Taiwan, R.O.C.
TEL : 886.3.560.1666 FAX : 886.3.560.1888