

Li-ion/Li Polymer Battery Charger in VDFN and VQFN Packages

General Description

The uP8001 is a highly integrated single-cell Li-ion or Li-Polymer battery charger specifically designed to work with AC adaptor or USB port.

The uP8001 charges battery with a minimum current when the battery voltage is lower than 2.8V. The charger works at constant current mode when the battery voltage is between 2.8V and 4.2V, the charge current is programmable up to 2A by an external resistor. The charge works at constant voltage mode when the battery voltage is 4.2V. When the input voltage is removed, the uP8001 automatically enters a low quiescent current sleep mode, dropping the battery drain current to 1uA.

Other features include thermal foldback charge current, NTC thermistor interface and automatic recharge. The uP8001 is available in thermal-enhanced and space-saving VQFN and VDFN packages.

Applications

- ❑ Cellular Phones
- ❑ Handheld Computers and PDAs
- ❑ Charging Docks and Cradles
- ❑ USB Powered Chargers
- ❑ Other Portable Applications

Features

- ❑ Complete Charger for 1-Cell Li-ion Batteries
- ❑ Integrated Pass Element and Current Sensor
- ❑ No External Blocking Diode Required
- ❑ 1% Voltage Accuracy
- ❑ Programmable Charge Current up to 2A
- ❑ Programmable End-of Charge Current
- ❑ NTC Interface for Battery Temperature Sensing
- ❑ Battery Insertion Detection
- ❑ 1uA Battery Drain Current when Input Voltage is Removed
- ❑ Automatic Trickle Charging of Low Voltage Cells
- ❑ Automatic Battery Recharge
- ❑ RoHS Compliant and 100% Lead (Pb)-Free

Ordering Information

Order Number	Package Type	Remark
uP8001ADAA-XX	VDFN3x3 - 10L	XX, Battery Voltage 41: 4.1V, 42: 4.2V
uP8001AQAD-XX	VQFN4x4 - 16L	

Note: uPI products are compatible with the current IPC/ JEDEC J-STD-020 and RoHS requirements. They are 100% matte tin (Sn) plating and suitable for use in SnPb or Pb-free soldering processes.

Pin Configuration & Typical Application Circuit

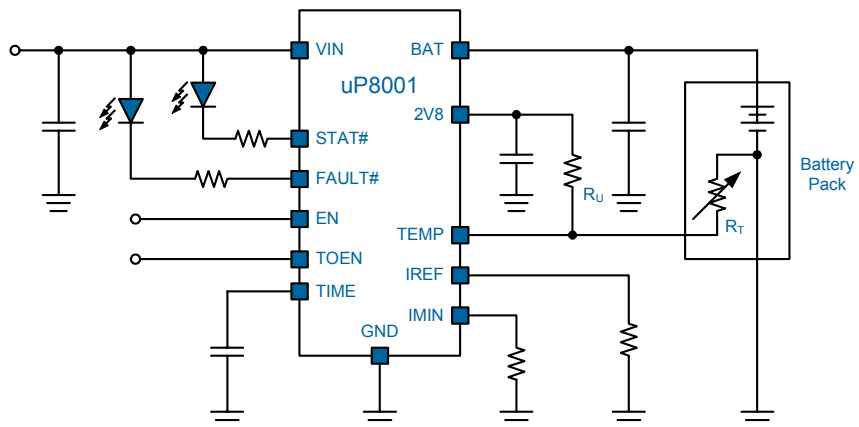
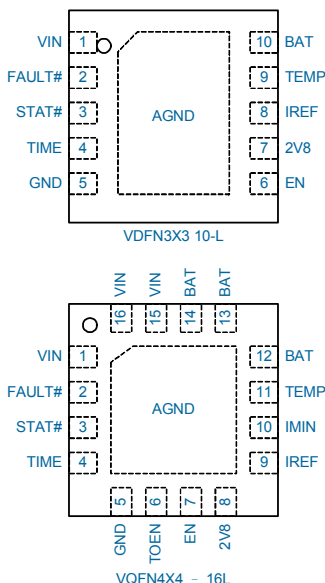

Functional Pin Description

Pin No.		Pin Name	Pin Function
VQFN	VDFN		
1, 15, 16	1	VIN	Supply Input. Connect this pin to a wall adaptor. A minimum 2.2uF ceramic from this pin to GND is required for stable operation of the charger.
2	2	FAULT#	Fault Indication. This pin is an open-drain output indicating fault status. This pin is pulled to LOW under any fault conditions.
3	3	STAT#	Charger Status Indication. This pin is an open-drain output indicating charging status. This pin is pulled to LOW when the charger is charging a battery.
4	4	TIME	Oscillation Period. Connect a timing capacitor between TIME and GND pins to determine the oscillation period. This oscillation period provides a time reference for the charger.
5	5	GND	Ground. Connect this pin to system ground. All voltage is measured with respect to this pin.
6	NA	TOEN	Time Out Enable Input. Pulling this pin to GND disables the timeout charge-time limit for fast charge modes. Let this pin float or pull this pin high to enable the timeout limit.
7	6	EN	Enable Input. Pulling this pin to GND disables the charger. Let this pin float or pull this pin high to enable the charger.
8	7	2V8	2.8V Reference Output. This pin outputs a 2.8V voltage source when the input voltage is above POR threshold level. This pin is capable of sourcing 2mA output current.
9	8	IREF	Constant Charging Current Programming. Connect a resistor between IREF and GND pins to program reference current I_{REF} for constant current charging mode.
10	NA	IMIN	Minimum Charging Current Programming. Connect a resistor between IMIN and GND pins to program minimum current level for end-of-charge decision. Minimum current is internally set to 1/10 of I_{REF} when this pin is floating or connected to 2V8 pin.
11	9	TEMP	Temperature and Battery Removal Detection Input. Connect this pin NTC thermal output of battery pack.
12, 13, 14,	10	BAT	Battery Output. Connect this pin to the positive terminal of battery pack. A minimum 2.2uF capacitor is required for stable operation of the charger.

Functional Block Diagram

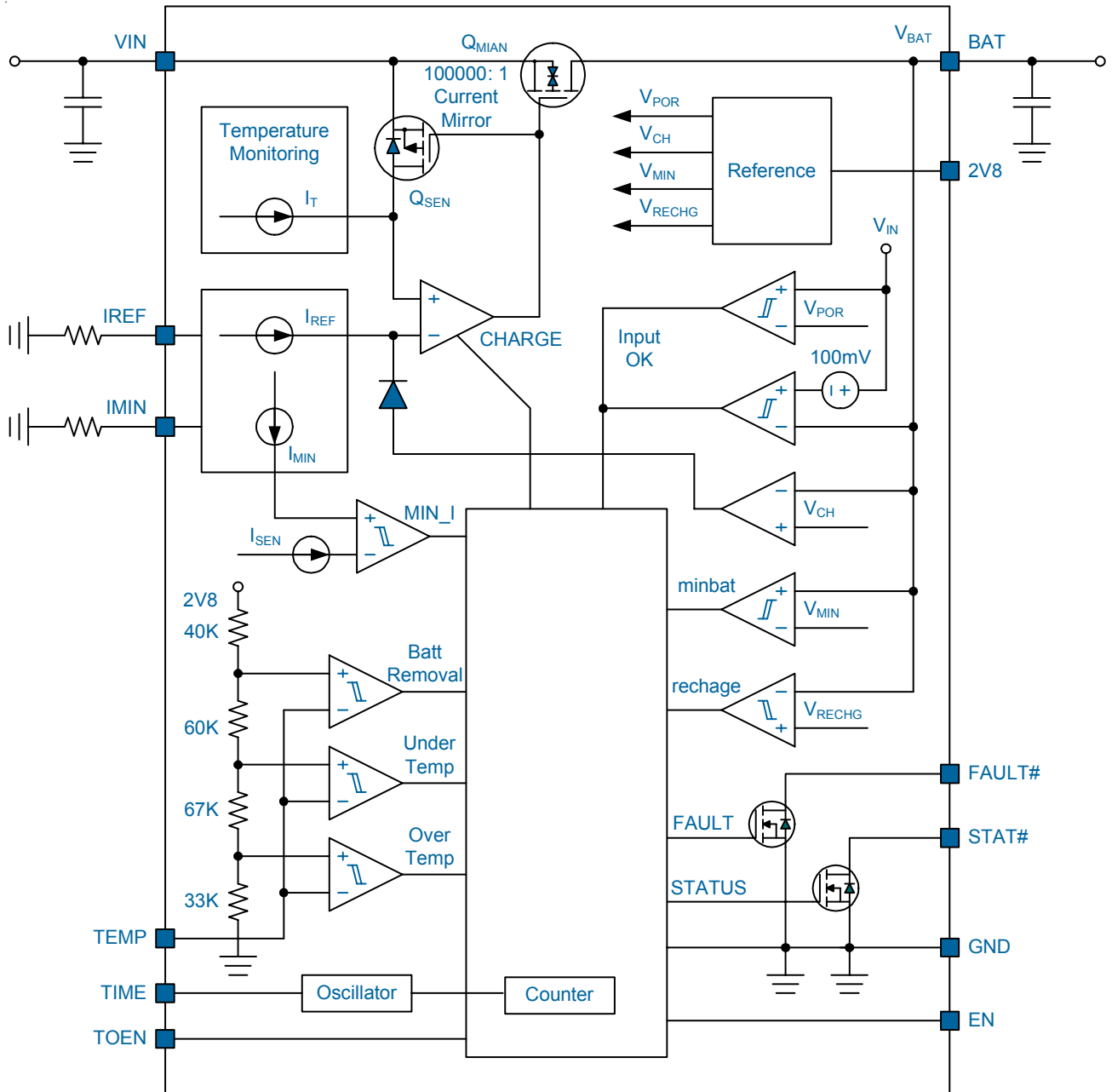

Functional Description

The uP8001 is a highly integrated single-cell Li-ion or Li-Polymer batter charger specifically designed to work with AC adaptor or USB port.

The uP8001 charges battery with a minimum current when the battery voltage is lower than 2.8V. The charger works at constant current mode when the battery voltage is between 2.8V and 4.2V, the charge current is programmable up to 2A by an external resistor. The charger works at constant voltage mode when the battery voltage is 4.2V. When the input voltage is removed, the uP8001 automatically enters a low quiescent current sleep mode, dropping the battery drain current to 1uA.

Other features include thermal foldback charge current, NTC thermistor interface and automatic recharge. The uP8001 is available in thermal-enhanced and space-saving VQFN and VDFN packages.

Power On Reset (POR)

The input voltage is continuously monitored for power on reset (POR). The uP8001 resets itself as the input voltage rises above the POR rising threshold, typically 3.4V. The device shuts down if the input voltage is under its POR falling threshold, typically 2.4V, and draws less than 1uA quiescent current from the battery.

Chip Enable and 2.8V Bias Voltage

The EN pin is internally pulled high to VIN pin for chip disable/enable. Pulling this pin to ground shuts down the uP8001 and disables the 2.8V bias voltage. When shut down, the charge draws typically less than 30uA current from the input power and less than 1uA from the battery.

When this pin is released from ground, the uP8001 is activated according to settings and battery status. Logic high of EN pin also enables the 2.8V bias voltage for biasing the internal control and logic circuit. This voltage also provides current for external circuits such as NTC thermistor circuit. The maximum allowed external load for 2V8 is 2mA.

Charge Cycle

A charge cycle can be initiated by anyone of the following events:

- power on reset,
- the EN pin is toggled from low to high,
- a new battery is inserted (detected by TEMP pin),
- the battery voltage drops below a recharge threshold after completing a charge cycle,
- recovery from a battery over-temperature or under-temperature fault,

A charge cycle consists of three charge modes: trickle mode (TKM), constant current mode (CCM), and constant voltage mode (CVM) as shown in Figure 1.

Trickle Mode

A charge cycle always starts with the trickle mode where minimum charging current is used. T1 and T6 indicate the starting of charge cycle that are initiated by VIN POR and recharge threshold respectively. The uP8001 leaves TKM and enters CCM at T2 and T7 if the battery voltage stays above V_{MIN} (2.8V typical) for 15 consequently cycles of the internal oscillator. The uP8001 enters TKM and the 15-cycle counter is reset whenever the battery voltage drops below

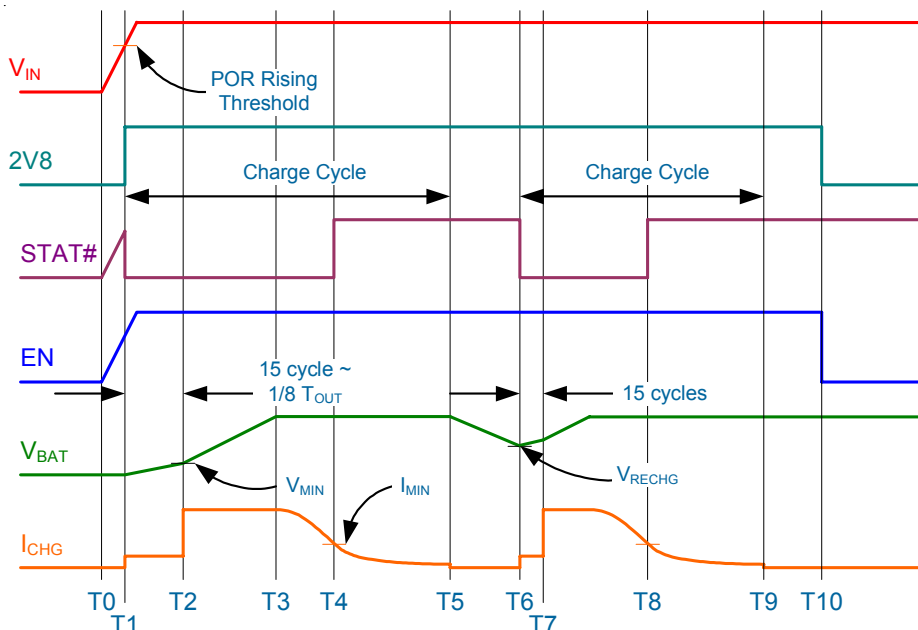

Figure 1. Typical Charge Cycles of uP8001.

Functional Description

 V_{MIN}

Constant Current Mode

The uP8001 operates at CCM when the battery voltage is between 2.8V and V_{CH} (Charge High Voltage, 4.1V for uP8001-41, 4.2V for uP8001-42). The charger acts like a constant current regulator. The charge current I_{REF} is programmed up to 2A (1.5A for VDFN3x3 package) by the IREF pin, see the *Charge Current Programming* section for detail.

Constant Voltage Mode

The uP8001 operates at CVM when the battery voltage reaches the charge high voltage V_{CH} . The charger acts like a constant voltage regulator that regulates the battery terminal voltage at V_{CH} . The charge current is determined by the battery impedance and core voltage. The uP8001 asserts end-of-charge and sets STAT# high impedance at T4 and T8 when the charge current is less than I_{MIN} (See *End-Of-Charge Current* section for detail).

The charging cycle is actually not terminated until charge timeout is completed to bring the battery to its full capacity.

Recharge

After a charge cycle completes, charging is prohibited until the battery voltage drops to a recharge threshold, V_{RECHG} . Then a new charge cycle starts at point T6 and ends at point T9, as shown in Figure 1. The timeout counter is reset at T6.

Charge Current Setting

An external resistor R_{IREF} connecting between IREF and ground programs the charge current. The voltage at IREF pin V_{IREF} is regulated to 0.8V reference voltage when it is left open. The charging current I_{REF} at CCM is 100,000 times of the current through R_{IREF} as the following equation:

$$I_{REF} = \frac{V_{IREF}}{R_{IREF}} \times 100,000 = \frac{0.8V}{R_{IREF}} \times 10^5 \quad (A)$$

The charge current is set to 100mA when IREF pin is pulled lower than 0.4V. The IREF pin is capable of sourcing 100uA. The external circuit must be able to sink at least 100uA to pull low this pin under 0.4V.

The charge current is set to 500mA when IREF pin is pulled higher than 1.3V. No special concern is required for sourcing capability of the external circuit to pull high this pin above 1.3V.

End-of-Charge (EOC) Current

A resistor R_{IMIN} connecting between IMIN pin and ground set the end-of-charge current I_{MIN} . The uP8001 asserts end-

of-charge and set STAT# pin high impedance if the charge current is lower than I_{MIN} . The charger actually does not terminate charging until the end of the TIMEOUT, as described in the Total Charge Time section. The voltage at IMIN pin V_{IMIN} is regulated to 0.8V reference voltage when it is left open. The EOC current I_{MIN} is 10,000 times of the current through R_{IMIN} and is governed by the following equation:

$$I_{MIN} = \frac{V_{IMIN}}{R_{IMIN}} \times 10,000 = \frac{0.8V}{R_{IMIN}} \times 10^4 \quad (A)$$

Another way to set I_{MIN} is connecting IMIN pin to 2V8 pin. This sets I_{MIN} to 1/10 of I_{REF} . For the uP8001 in VDFN3x3 package, the IMIN pin is connected internally to 2V8 pin.

However, if IREF is shorted to ground, I_{MIN} is automatically set to 5mA and cannot be changed externally.

Total Charge Time

An external timing capacitor C_{TIME} connecting between TIME pin and ground programs a timing reference. The uP8001 charges/discharges the C_{TIME} between 1.5V and 0.5V, both with 10uA current source. The oscillation period is described by the following equation:

$$T_{OSC} = 2 \times 10^5 \times C_{TIME} \quad (\text{second})$$

A 22-stage binary counter counts the timing oscillation and limits the total charge time T_{CHG} for the CCM and CVM. The T_{CHG} can be calculated as:

$$T_{OUT} = 2^{22} \times T_{OSC} = 8.39 \times 10^{11} \times C_{TIME} \quad (\text{second})$$

A 15nF C_{TIME} results in a 3.0ms oscillation period and 3.5 hours charge time. The charger MUST reach the end-of-charge status within T_{OUT} . Otherwise, a TIMEOUT fault is triggered and latches up the charge. Once latched by TIMEOUT fault, the charge can only be reset by V_{IN} POR or toggling the EN pin.

The TKM also has a time limit of $1/8 T_{OUT}$. A TIMEOUT fault is triggered and latches up the charger if the battery voltage does not reach V_{MIN} within this limit. Therefore, the charge stays in trickle mode for at least $15 \times T_{OSC}$ and, at most $1/8$ of T_{OUT} as shown in Figure 1.

Disabling TIMEOUT Limit

Pulling the TOEN pin low disables the timeout limit. The charge behaviors like a current-limited LDO regulator with its output voltage set to V_{CH} . The STAT# pin is set high impedance if charge current drops below I_{MIN} , and pulled low if charge current is higher than I_{MIN} . There is no recharge cycle at this mode.

The time limit for trickle mode is not disabled even the TOEN

Functional Description

pin is pulled low.

Let the TOEN pin float to enable the timeout function. The TOEN pin is left floating for the uP8001 in VDFN3x3 package.

Charge Current Thermal Foldback

Thermal issue always deserved great attentions for a linear charger. The maximum power dissipation usually occurs at the beginning of constant current mode where the uP8001 charge the battery with maximum current and high dropout voltage.

The uP8001 integrated thermal shutdown function avoiding the charger from burning out. The thermal shutdown is triggered and latches up the charger when the junction temperature reaches 150°C typically. The uP8001 also integrates a thermal foldback function to ensure safe operation without triggering thermal shutdown when PCB space is limited for thermal dissipation as shown in Figure 2. The uP8001 automatically reduces the charge current when the junction temperature rises above +120°C to prevent further temperature rise.

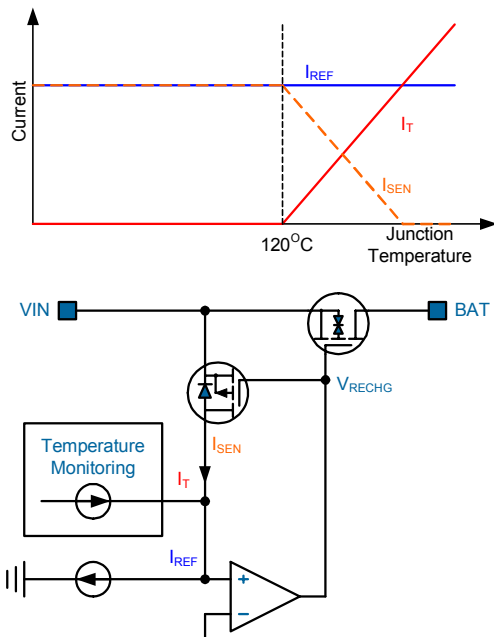

Figure 2. Charge Current Thermal Flodback.

I_{REF} is the current reference set by R_{IREF} connecting between IREF pin and ground. I_T is the current signal from Temperature Monitoring Block. I_T is kept zero and does not affect the charge current if the junction temperature is below +120°C. I_T rises at a rate of 1uA/°C and is added to the sensed current I_{SEN} when the junction temperature is over +120°C. This makes I_{SEN} decrease at a rate of -1uA/°C. The charge current decreases at a rate of -100mA/°C since it is

100,000 times mirrored of I_{SEN} . The charge current is reduced to zero when the junction temperature rises to +130°C for a charger with I_{REF} set to 1.0A. The actual charge current settles between +120°C and +130°C.

The uP8001 asserts end-of-charge only when the charge current is below I_{MIN} at constant voltage mode. If the charge current drops below I_{MIN} due to thermal foldback at constant current mode, the uP8001 will not assert end-of-charge.

NTC Thermistor

Use a NTC thermistor to form a voltage divider at TEMP pin for monitoring the battery pack as shown in Figure 3. CP2 and CP3 are Schmitt Triggers for upper and lower boundary, V_{TMAX} and V_{TMIN} , of temperature window comparator respectively. The uP8001 stops charging and set FAULT# pin low if the voltage at TEMP pin is out of the window. The uP8001 sets FAULT# pin high impedance and starts another charge cycle when the voltage TEMP is within the window again.

The temperature accuracy does not depend on the accuracy of 2.8V bias voltage since both reference voltages V_{TMIN} and V_{TMAX} and voltage at TEMP are percentages of the bias voltage. However, uP8001 provides a 2.8V with 2% high accuracy in case that the TEMP pin voltage is also monitored by other ASIC on the PCB for redundant thermal protection.

The lower temperature boundary is $V_{TMIN} = 1.4V$ that is 1/2 of the 2.8V bias voltage. This needs $R_U = (R_L + R_{TMIN})$ at low temperature limit, where R_U is the pull-high resistor, R_L is the pull-low resistor, and R_{TMIN} is the thermistor resistance at low temperature limit.

On the other hand, the voltage at TEMP pin at high temperature limit should be:

$$2.8V \times \frac{R_L + R_{TMAX}}{R_U + R_L + R_{TMAX}} = 0.467V$$

=1/6 of the 2.8V bias voltage.

$$(R_L + R_{TMAX}) = (R_L + R_{TMIN}) / 5$$

where R_{TMAX} is the thermistor resistance at high temperature limit. The NTC thermistor must have a resistance ratio of 5:1 at least at the low and the high temperature limits.

Functional Description

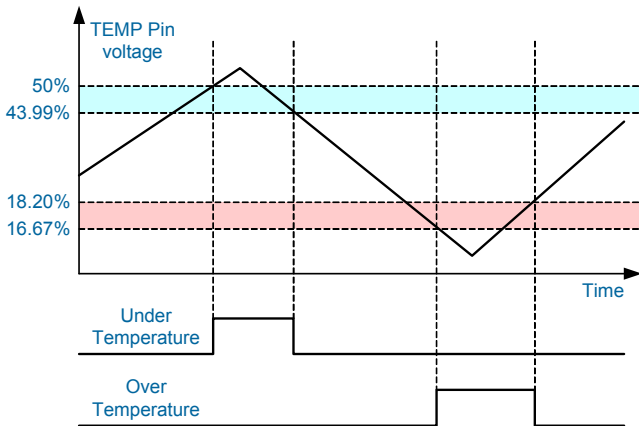
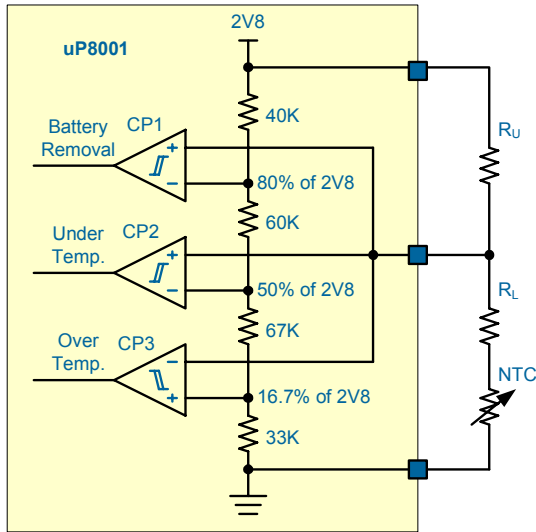

Figure 3. Battery Temperature Monitoring.

Battery Removal Detection

The uP8001 assumes that the NTC thermistor is co-packed with the battery and is removed together with the battery. The TEMP pin is pulled high to 2V8 if the NTC is removed. The uP8001 asserts the removal of battery, stops the charging cycle and sets FAULT# pin low if TEMP voltage is higher than 2.1V. A new charge cycle starts if a battery is inserted again.

For applications that do not support battery thermal detection, set TEMP voltage as 1/3 of 2V8 bias voltage by an external resistive voltage divider.

Indications

The uP8001 has three indications: the input presence, the charge status, and the fault indication. The input presence is indicated by the 2V8 pin while the other two indications are presented by the STAT# pin and FAULT# pin respectively.

The 2V8 pin voltage is enabled and regulated typical 2.8V if input voltage POR is granted and the chip is enabled. This pin is capable of sourcing 2mA output current and can be used as the power present indication. Figure 4 shows the 2V8 pin voltage vs. the input voltage.

The STAT# pin is an open-drain logic output that is pulled low when the charger is in charge states (from the beginning of a charge cycle to the end-of-charge condition is qualified.) The EOC condition is: the battery voltage is within VCH and VRECHG and the charge current falls below a user programmable EOC current threshold. The STAT# pin is set to high impedance and latched once the EOC condition is granted. The latch is released at the beginning of another charge or recharge cycle.

The FAULT# pin is an open-drain logic output that is pulled when any fault conditions occur. The fault conditions include the external battery temperature fault, the battery removal , or a timeout fault. The STAT# pin is set to high impedance when the fault conditions are removed.

Absolute Maximum Rating

Supply Input Voltage, V_{IN} (Note 1)	-0.3V to +6V
Output Pin Voltage, BAT	-0.3V to +5.5V
Signal Input Voltage	-0.3V to +3.2V
Signal Output Voltage	-0.3V to +6V
Charge Current for VQFN 4x4 Package	2.1A
Charge Current for VDFN 3x3 Package	1.6A
Storage Temperature	-65°C to +150°C
Junction Temperature	150°C
Lead Temperature (Soldering, 10 sec)	260°C
ESD Rating (Note 2)	
HBM (Human Body Mode)	2kV
MM (Machine Mode)	200V

Thermal Information

Package Thermal Resistance (Note 3)	
VDFN3x3 - 10L θ_{JA}	50°C/W
VQFN4x4 - 16L θ_{JA}	37°C/W
VDFN3x3 - 10L θ_{JC}	5°C/W
VQFN4x4 - 16L θ_{JC}	3°C/W
Power Dissipation, P_D @ $T_A = 70^\circ\text{C}$	
VDFN3x3	2.0W
VQFN4x4	2.7W

Recommended Operation Conditions

Operating Junction Temperature Range (Note 4)	-40°C to +125°C
Operating Ambient Temperature Range	-40°C to +85°C
Supply Input Voltage, V_{IN}	+4.5V to +5.5V

Electrical Characteristics

($V_{IN} = 5\text{V}$, $T_A = 25^\circ\text{C}$, unless otherwise specified)

Parameter	Symbol	Test Conditions	Min	Typ	Max	Units
Supply Input						
Supply Input Range	V_{IN}		4.5	--	5.5	V
V_{IN} POR Rising Threshold			--	3.4	4.0	V
V_{IN} POR Falling Threshold			--	2.4	--	V
Standby Current						
BAT Pin Sink Current	I_{SB}	VIN floating or EN = Low	--	--	2.0	uA
VIN Pin Supply Current	I_{VIN}	BAT floating and EN = Low	--	20	--	uA
VIN Pin Supply Current	I_{VIN}	BAT floating and EN floating	--	0.7	--	mA
Voltage Regulation						
Output Voltage	V_{CH}	uP8001-41	4.059	4.10	4.141	V
Output Voltage	V_{CH}	uP8001-42	4.158	4.20	4.242	V
Dropout Voltage		$V_{BAT} = 4.0\text{V}$, 0.5A, 4x4 package	--	120	--	mV
Dropout Voltage		$V_{BAT} = 4.0\text{V}$, 0.5A, 3x3 package	--	120	--	mV

Electrical Characteristics

Parameter	Symbol	Test Conditions	Min	Typ	Max	Units
Charge Current						
Constant Charge Current	I_{CHG}	$R_{IREF} = 78k\Omega, V_{BAT} = 3.7V$	900	1000	1100	mA
Constant Charge Current	I_{CHG}	$V_{IREF} > 1.2V, V_{BAT} = 3.7V$	430	490	550	mA
Constant Charge Current	I_{CHG}	$V_{IREF} < 0.4V, V_{BAT} = 3.7V$	--	95	--	mA
Trickle Charge Current	I_{TRK}	$R_{IREF} = 78k\Omega, V_{BAT} = 2.0V$	--	95	--	mA
Trickle Charge Current	I_{TRK}	$V_{IREF} > 1.2V, V_{BAT} = 2.0V$	--	45	--	mA
Trickle Charge Current	I_{TRK}	$V_{IREF} < 0.4V, V_{BAT} = 2.0V$	--	9	--	mA
End-of-Charge Threshold	I_{TER}	$R_{MIN} = 78k\Omega$	85	100	115	mA
Threshold Voltage						
Recharge Voltage Threshold	V_{RCHG}	uP8001-42	--	4.0	--	V
Recharge Voltage Threshold	V_{RCHG}	uP8001-41	--	3.9	--	V
Trickle Charge Threshold Voltage	V_{MIN}		2.74	2.8	2.86	V
2V8						
2V8 Output Voltage	V_{2V8}		2.74	2.80	2.86	V
2V8 Soucing Current	I_{2V8}		2	--	--	mA
Oscillator						
Oscillation Period	T_{OSC}	$C_{TIME} = 15nF$	2.7	3.0	3.3	ms
Temperature Monitoring						
Low Temperature Threshold	V_{TMIN}	$V_{2V8} = 2.8V$	1.35	1.40	1.45	V
High Temperature Threshold	V_{TMAX}	$V_{2V8} = 2.8V$	449	467	485	mV
Battery Removal Threshold	V_{RMV}	$V_{2V8} = 2.8V$	--	2.24	--	V
Charge Current Foldback Threshold	T_{FOLD}		105	120	135	°C
Current Foldback Gain	G_{FOLD}		-	100	--	mA/°C
Logic Input and Output						
TOEN Input High			2.0	--	--	V
TOEN and EN Input Low			--	--	0.8	V
IREF and IMIN Input High			1.2	--	--	V
IREF and IMIN Input Low			--	--	0.4	V
STAT# and FAULT# Sink Current		Pin Voltage = 0.4V	5	--	--	mA

Note 1. Stresses listed as the above "Absolute Maximum Ratings" may cause permanent damage to the device. These are for stress ratings. Functional operation of the device at these or any other conditions beyond those indicated in the operational sections of the specifications is not implied. Exposure to absolute maximum rating conditions for extended periods may remain possibility to affect device reliability.

Note 2. Devices are ESD sensitive. Handling precaution recommended.

Note 3. θ_{JA} is measured in the natural convection at $T_A = 25^\circ C$ on a low effective thermal conductivity test board of JEDEC 51-3 thermal measurement standard.

Note 4. The device is not guaranteed to function outside its operating conditions.

Typical Operation Characteristics

Leakage Current vs Battery Voltage

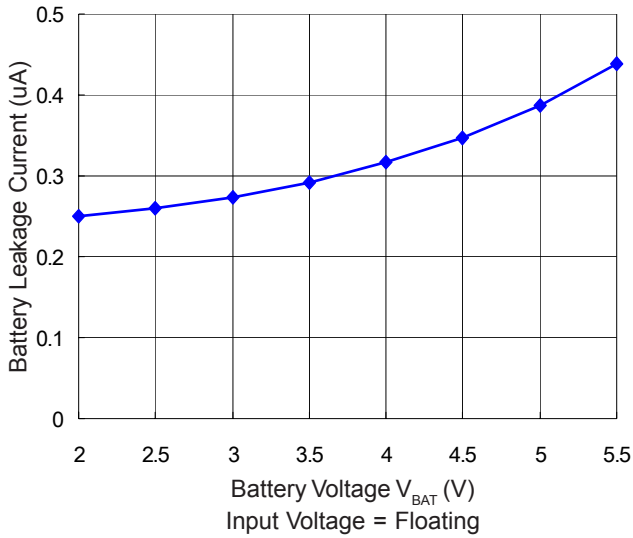

Shutdown Current vs. Input Voltage

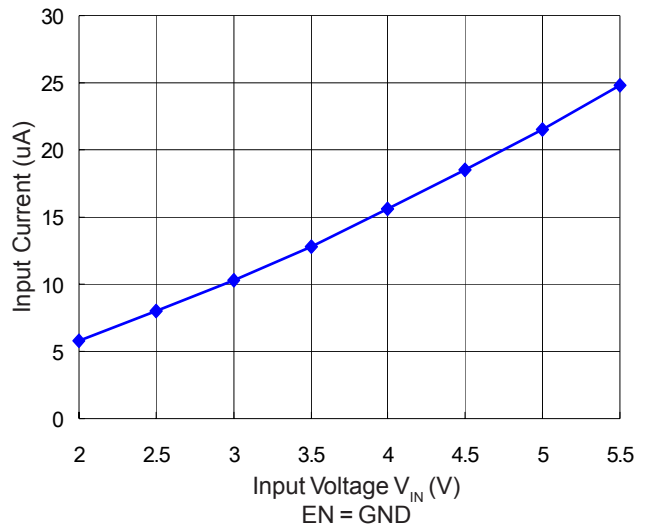

2V8 Voltage vs. Input Voltage

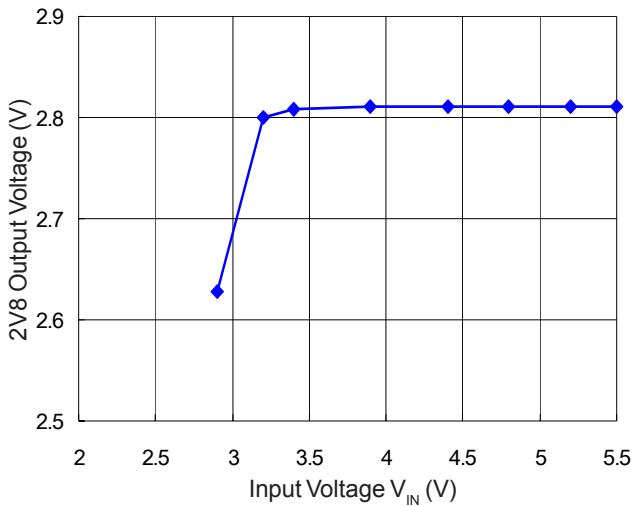

2V8 Voltage Load Regulation

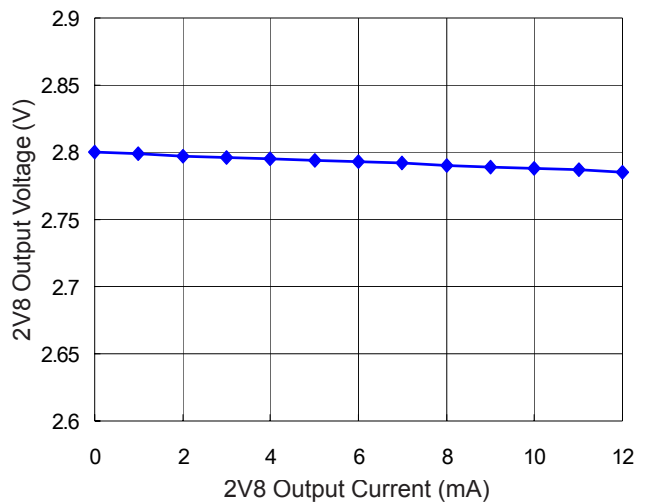

IREF Voltage vs. Input Voltage

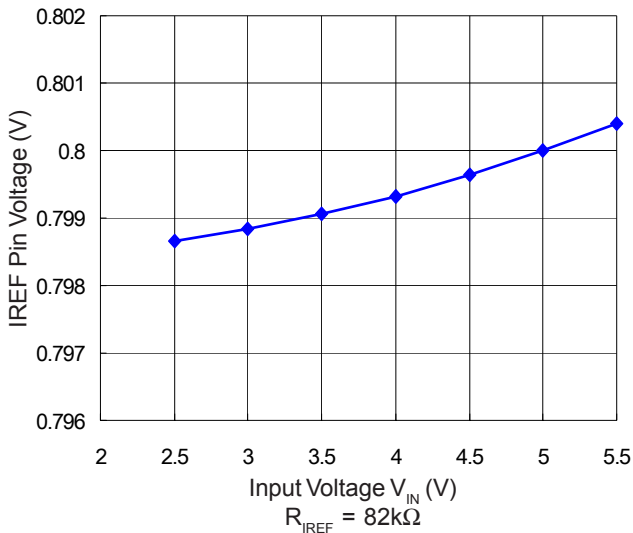

FAULT# and STAT# Sinking Capability

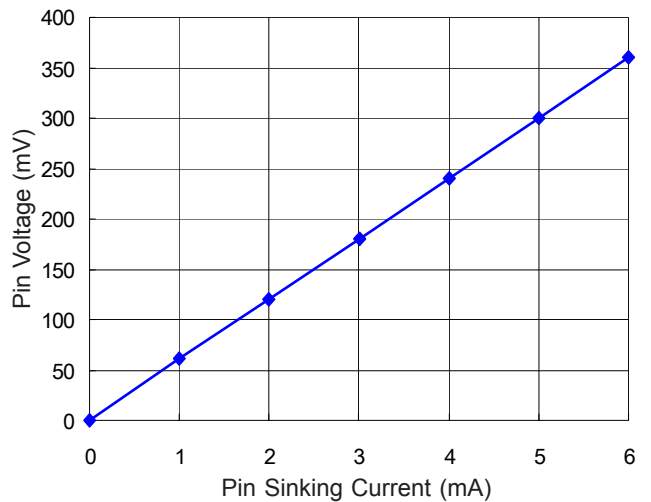

Typical Operation Characteristics

Typical Charge Cycle I

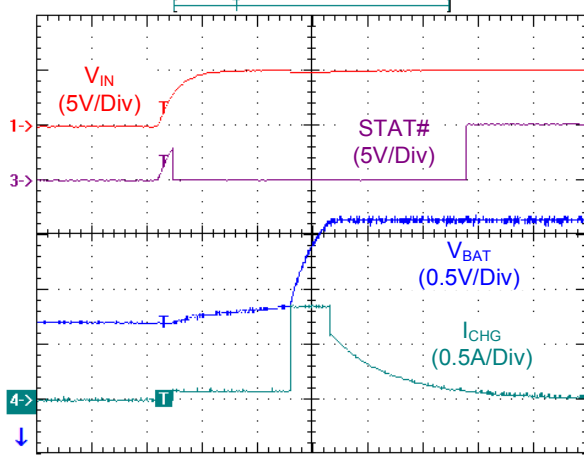

Power on by V_{IN}

Typical Charge Cycle II

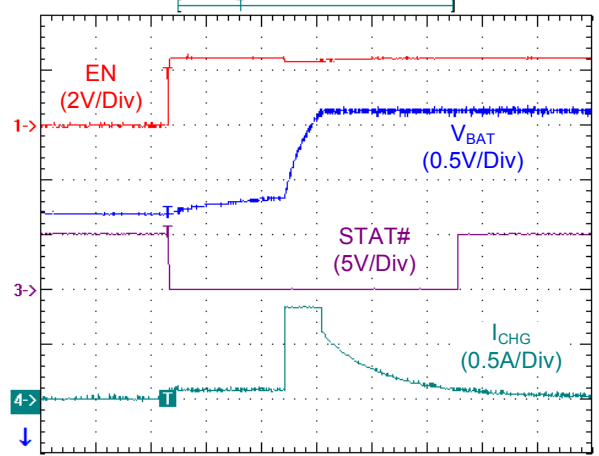

Turn on by EN

TIME Pin Waveform

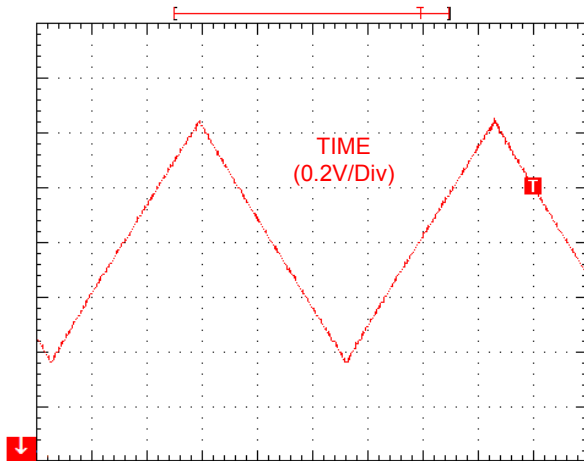

Time (250us)
 $C_{TIME} = 10nF$

Application Information

The uP8001 is a highly integrated single-cell Li-ion or Li-Polymer batter charger specifically designed to work with AC adaptor or USB port.

The uP8001 charges battery with a minimum current when the battery voltage is lower than 2.8V. The charger works at constant current mode when the battery voltage is between 2.8V and 4.2V, the charge current is programmable up to 2A by an external resistor. The charge works at constant voltage mode when the battery voltage is 4.2V. When the input voltage is removed, the uP8001 automatically enters a low quiescent current sleep mode, dropping the battery drain current to 1uA.

Other features include thermal foldback charge current, NTC thermistor interface and automatic recharge. The uP8001 is available in thermal-enhanced and space-saving VQFN and VDFN packages.

Input and Output Capacitors Selection

The charger acts like a constant current and constant linear regulator at CCM and CVM respectively. Input and output capacitors are necessary for stable operation of the charger.

Place a minimum 2.2uF input capacitor and a minimum 2.2uF output capacitor phycially near the charger.

PCB Layout Consideration

The PCB acts as main heat dissipation path for uP8001. Propoer PCB design maximizes heat dissipation capability and the charge current capability.

The exposed pad should be properly soldered to the PCB and connected to inner ground plane through as many thermal vias as possible. Place 9 thermal vias on the thermal pad of VQFN4x4 package and place 8 thermal vias on the thermal pad of VDFN3x3 package. Also connect as much top-layer cooper as possible to the exposed pad of VDFN package to minimize the thermal resistance.

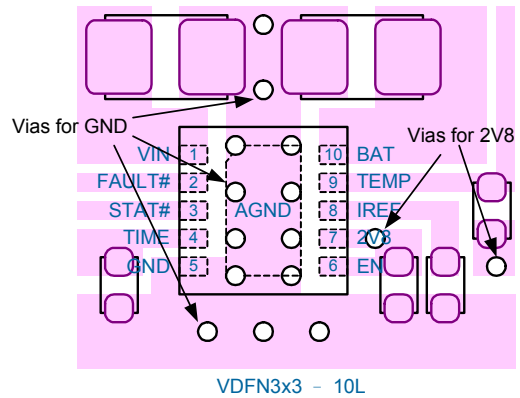
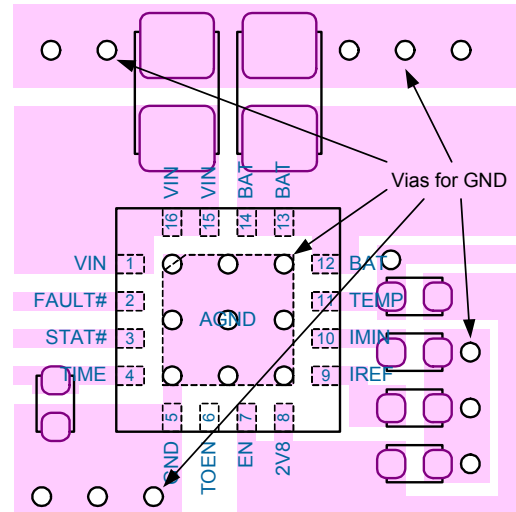
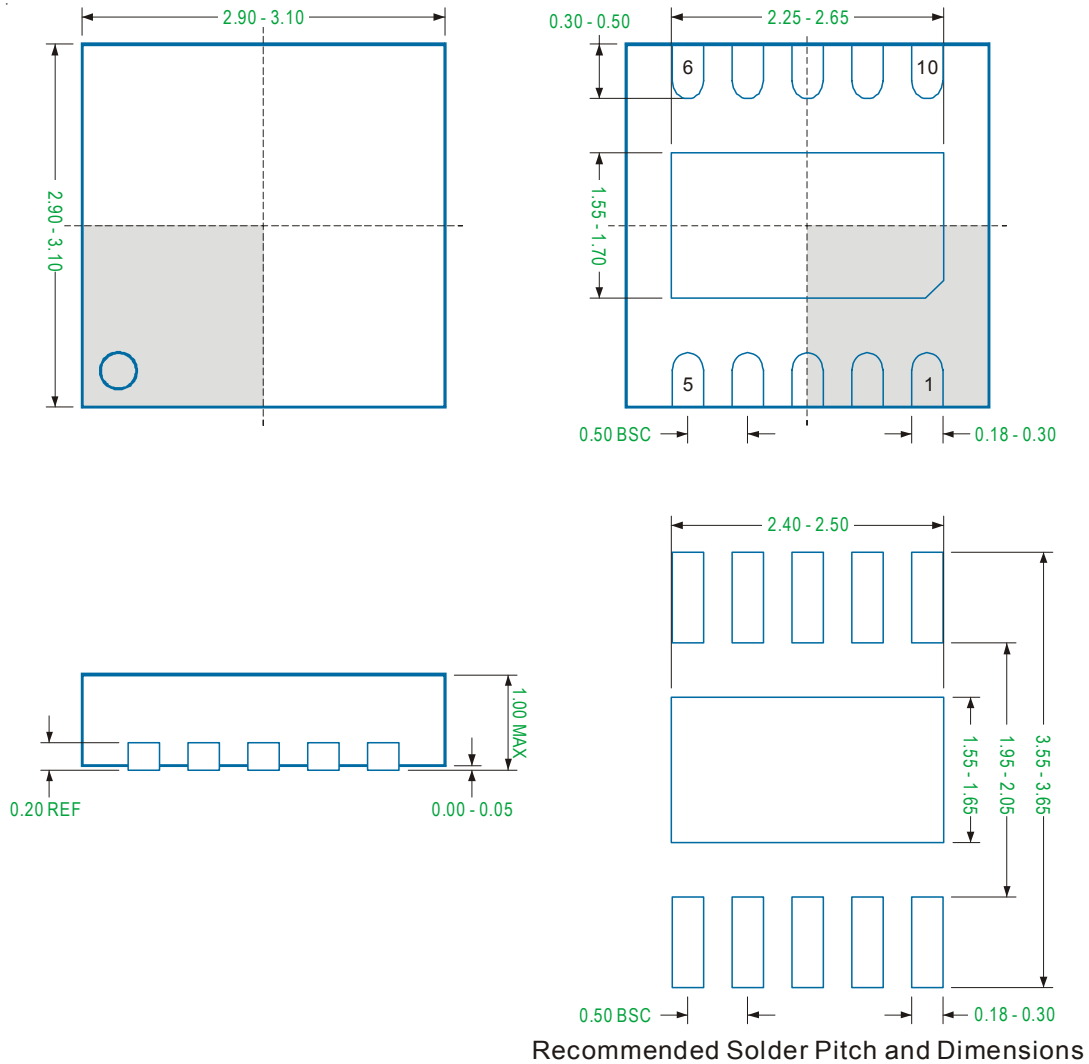

Figure 1. Top Layer Layout Examples

VDFN3x3 - 10L



Note

1. Package Outline Unit Description:

BSC: Basic. Represents theoretical exact dimension or dimension target

MIN: Minimum dimension specified.

MAX: Maximum dimension specified.

REF: Reference. Represents dimension for reference use only. This value is not a device specification.

TYP: Typical. Provided as a general value. This value is not a device specification.

2. Dimensions in Millimeters.

3. Drawing not to scale.

4. These dimensions do not include mold flash or protrusions. Mold flash or protrusions shall not exceed 0.15mm.

VQFN4x4 - 16L

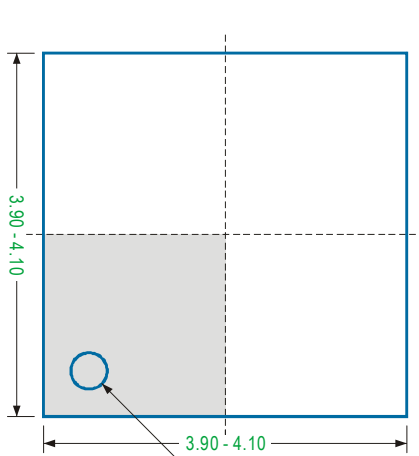

Pin 1 mark

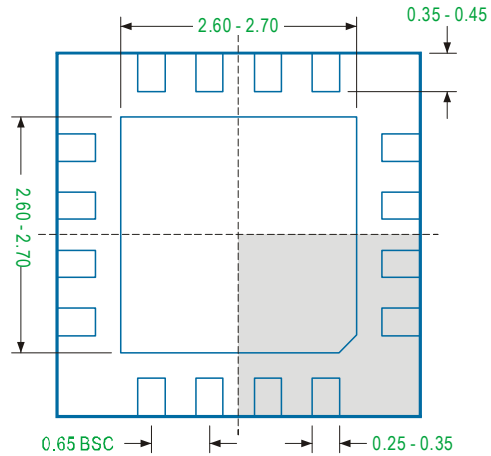

Bottom View - Exposed Pad

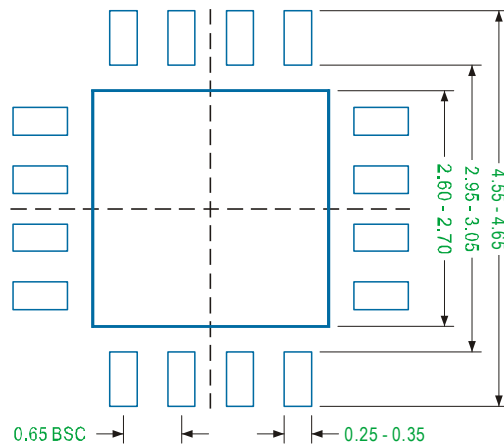
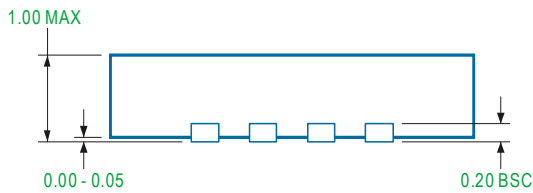

Recommended Solder Pad Pitch and Dimensions

Note

1. Package Outline Unit Description:

BSC: Basic. Represents theoretical exact dimension or dimension target

MIN: Minimum dimension specified.

MAX: Maximum dimension specified.

REF: Reference. Represents dimension for reference use only. This value is not a device specification.

TYP: Typical. Provided as a general value. This value is not a device specification.

2. Dimensions in Millimeters.

3. Drawing not to scale.

4. These dimensions do not include mold flash or protrusions. Mold flash or protrusions shall not exceed 0.15mm.