

3A , Wide Input Sensorless CC/CV Synchronous-Rectified Buck Converter

General Description

The uP9601T is a high-efficiency synchronous-rectified buck converter with an internal power switch. With internal low RDS(ON) switches, the high-efficiency buck converter is capable of delivering up to 3.0A output current for charger interface and a wide input voltage range from 8.0V to 32V. It operates in either CV (Constant Output Voltage) mode or CC (Constant Output Current) mode, and provides a current limitation function. The uP9601T is constant output voltage 5.1V for car charger application.

Other features for the buck converter include internal soft-start, adjustable external CC (Constant Output current) limit setting, chip enable, built-in fixed and adjustable line-compensation, short circuit protection, VIN/VOUT over voltage protection and over temperature protection. It is available in a space saving PSOP-8L package.

Ordering Information

Order Number	Package Type	Top Marking
uP9601TSW8	PSOP-8L	uP9601T

Note:

(1) Please check the sample/production availability with uPI representatives.

(2) uPI products are compatible with the current IPC/JEDEC J-STD-020 requirement. They are halogen-free, RoHS compliant and 100% matte tin (Sn) plating that are suitable for use in SnPb or Pb-free soldering processes.

Features

- ❑ Wide Input Voltage Range : 8.0V to 32V
- ❑ Input Voltage Absolute Maximum Rating : 36V
- ❑ Up to 3.0A Output Current
- ❑ CV/CC Mode Control (Constant Voltage and Constant Current)
- ❑ Output Constant Voltage: 5.1V
- ❑ Output Voltage Accuracy: $\pm 1.5\%$
- ❑ Fixed 135kHz Frequency Operation
- ❑ Up to 95% Conversion Efficiency
- ❑ Internal Soft Start: 12ms
- ❑ Adjustable Line Compensation and Fixed Cable Compensation Voltage
- ❑ Adjustable External Current Limit Setting: Default = 2.6A
- ❑ CC (Constant Output Current) Limit Accuracy: $\pm 3\%$
- ❑ Short Circuit Protection
- ❑ VIN/VOUT Over Voltage and Over Temperature Protections
- ❑ Available in PSOP-8L Package
- ❑ RoHS Compliant and Halogen-Free

Applications

- ❑ PDA Like Device Car Chargers
- ❑ Portable Charging Devices

Pin Configuration

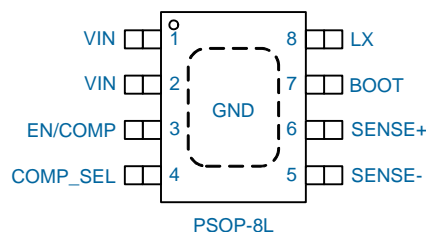

Typical Application Circuit

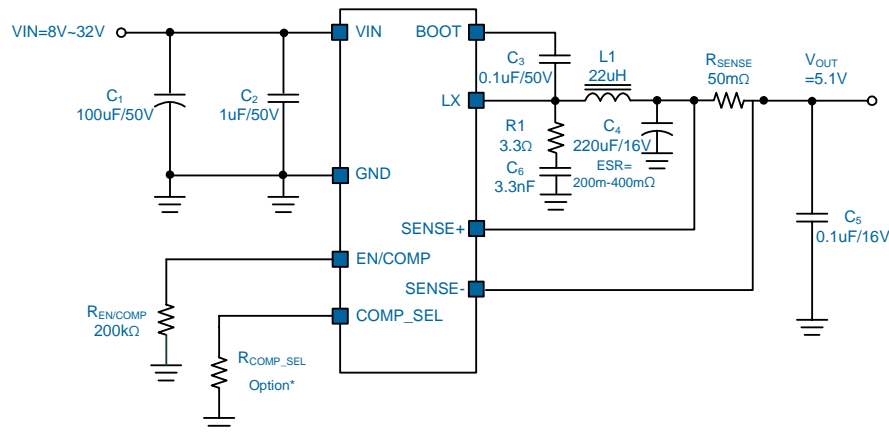

Functional Pin Description

Pin No.	Pin Name	Pin Function
1	VIN	Power Supply Input. Input voltage that supplies current to the output voltage and powers the internal control circuit. Bypass the input voltage with a minimum 1uF x 1 X5R or X7R ceramic capacitor.
2		
3	EN/COMP	Car Charger Enable (Active High) and Adjustable Cable Compensation. Pulling EN/COMP pin <14kΩ to GND disables the car charger, and the EN/COMP pin internally pulls high to enable the car charger. Connect a resistor between EN/COMP and GND pins to adjust USB cable compensation to prevent output voltage drop in the output cable.
4	COMP_SEL	External Control Signal. Floating (signal H) or connect a resistor <200kΩ between COMP_SEL and GND pins (signal L) to select USB cable compensation to prevent output voltage drop in the output cable.
5	SENSE-	The Current Sense Input (-) Pin. Adjustable line and cable compensation voltage.
6	SENSE+	The Current Sense Input (+) Pin. Adjustable line and cable compensation voltage.
7	BOOT	Bootstrap Supply for the Floating Upper Gate Driver. Connect the bootstrap capacitor C BOOT between BOOT pin and the LX pin to form a bootstrap circuit. The bootstrap capacitor provides the charge to turn on the upper MOSFET. Typical value for C BOOT is 0.1uF or greater. Ensure that C BOOT is placed near the IC.
8	LX	Internal Switches Output. Connect this pin to the output inductor.
Exposed Pad (GND)		Ground. Ground of the buck converter. The exposed pad is the main path for heat convection and should be well-soldered to the PCB for best thermal performance.

Functional Block Diagram

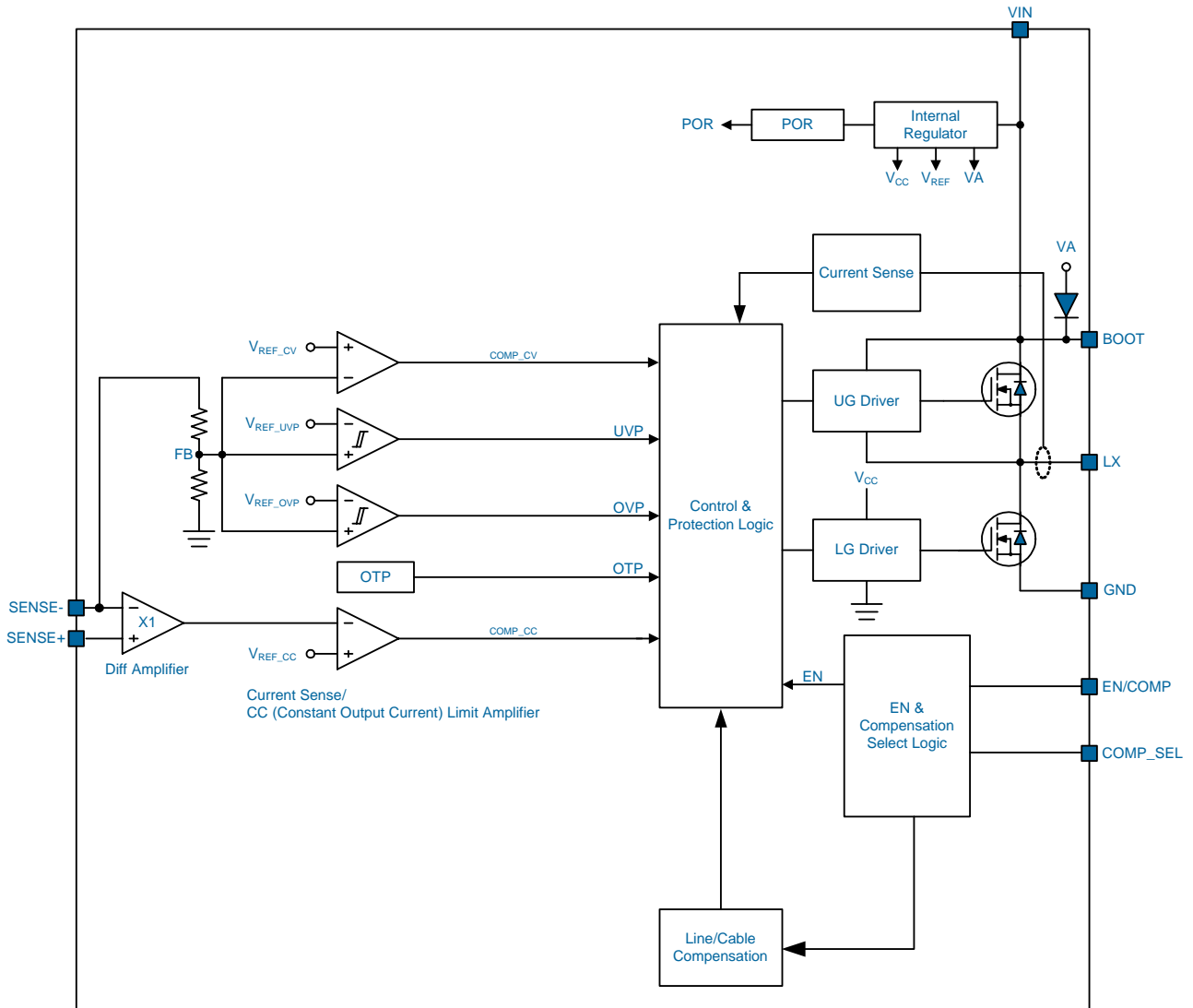

Functional Description

CV/CC Mode Control

The uP9601T provides CV/CC function. It operates in either CV (Constant Output Voltage) mode or CC (Constant Output Current) mode and provides a current limitation function and adjusts external current limit setting (default = 2.6A). In the CV mode, the output voltage is controlled within ±1.5%. In the CC mode, the output current variation is less than ±3% of the nominal value which can be set up to 3A by the current sensing resistor.

When Output current increases until it reaches the CC limit set by the R_{SENSE} resistor, the device will switch from regulating output voltage to regulating output current, and the output voltage will drop with increasing load.

The CC (Constant Output Current) limit is set at 2.6A by default with an external resistance $R_{SENSE} = 50m\Omega$. When the (SENSE1+) - (SENSE1-) voltage gets higher than 130mV and reaches the current limit, the driver is turned off. The CC (Constant Output Current) limit is set according to the following equation:

$$CC \text{ (Constant Output Current) Limit} = \frac{130mV}{R_{SENSE}}$$

USB Cable Resistance Compensation Select

Leave COMP_SEL pin floating (Signal H) or connect an R_{COMP_SEL} resistor < 200kΩ between COMP_SEL and GND pins (Signal L) to select USB cable compensation to prevent output voltage drop in the output cable, as shown in Figure 1 and Table 1.

Enable Control and Output Cable Resistance Compensation

The uP9601T pulling EN/COMP pin < 14kΩ to GND disables the car charger, and the EN/COMP pin internally pulls high to enable the car charger. Connect a resistor between EN/COMP and GND pins to adjust USB cable compensation

to prevent output voltage drop in the output cable.

In charger applications, the large load will cause voltage drop in the output cable. The uP9601T has a built-in cable compensation function. When the load increases, the cable compensator will increase the adjustable regulation of the error amplifier that keeps the output voltage constant. Use the graphs and table to adjust the internal reference voltage values for fixed USB and adjustable cable compensation by external resistance $R_{SENSE} = 50m\Omega$ (default), as shown in Figure 1 and Table 1. The R_{COMP} is an internal equivalent resistor. The fixed and adjustable cable compensation is calculated as follows:

$$V_{COMP} = I_{LOAD} \times R_{COMP}$$

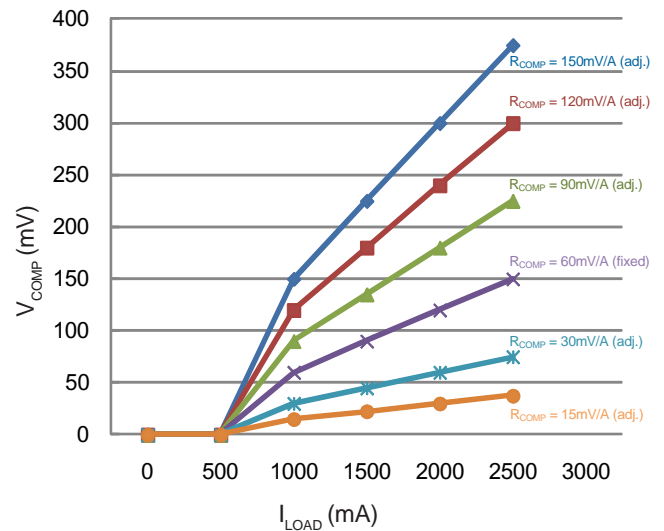

Figure 1 USB Cable Compensation at Various Resistor Divider Values

R_{SENSE} (mΩ)	50			50			35
R_{COMP_SEL} (kΩ)	Floating			100			100
$R_{EN/COMP}$ (kΩ)	43	91	200(default)	43	91	200	200
I_{LOAD} (mA)	USB Cable Compensation Voltage (mV)						
0	0	0	0	0	0	0	0
500	0	0	0	0	0	0	0
1000	15	30	60	90	120	150	105
1500	22.5	45	90	135	180	225	157.5
2000	30	60	120	180	240	300	210
2500	37.5	75	150	225	300	375	262.5
3000	NA	NA	NA	NA	NA	NA	315

Table 1 USB Cable Resistance Compensation Application Table

Current Limit Protection

The uP9601T continuously monitors the inductor current, when the inductor current is higher than current limit threshold, the current limit function activates and forces the upper switch to turn off to limit inductor current cycle by cycle.

Output Short Circuit Protection

The uP9601T provides output short circuit protection function. Once the output loader short-circuits, the SCP will be triggered and then always hiccup, the hiccup cycle time is set by an internal counter. When the SCP condition is removed or disappears, the converter will resume normal operation and the hiccup status will terminate.

Output Over Voltage Protection

The uP9601T provides output over voltage protection. Once the output voltage (measured the at SENSE- pin) gets higher than OVP threshold, the OVP will be triggered to shut down the converter. When the OVP condition disappears, the converter will resume normal operation and resume the normal state automatically.

Over Temperature Protection

The OTP is triggered and shuts down the uP9601T if the junction temperature is higher than 150°C The OTP is a non-latch type protection. The uP9601T automatically initiates another soft start cycle if the junction temperature drops below 130°C.

Absolute Maximum Rating

(Note 1)

Supply Input Voltage, V_{IN}	-----	-0.3V to +36V
LX to GND Voltage		
DC	-----	-0.3V to +36V
< 100ns	-----	-5V to +38V
VIN to LX Voltage		
DC	-----	-0.3V to +36V
< 100ns	-----	-5V to +38V
BOOT to LX Voltage		
DC	-----	-0.3V to +6V
< 100ns	-----	-5V to +7.5V
SENSE+/SENSE- Pin Voltage	-----	-0.3V to +14V
EN/COMP and COMP_SEL Pin Voltage	-----	-0.3V to +6.0V
Storage Temperature Range	-----	-65°C to +150°C
Junction Temperature	-----	150°C
Lead Temperature (Soldering, 10 sec)	-----	260°C
ESD Rating (Note 2)		
Sense- Pin		
HBM (Human Body Mode)	-----	4kV
MM (Machine Mode)	-----	400V
Other Pins		
HBM (Human Body Mode)	-----	2kV
MM (Machine Mode)	-----	200V

Thermal Information

Package Thermal Resistance (Note 3)

PSOP - 8L θ_{JA}	-----	47°C/W
PSOP - 8L θ_{JC}	-----	17.9°C/W
Power Dissipation, P_D @ $T_A = 25^\circ\text{C}$		
PSOP - 8L	-----	2.13W

Recommended Operation Conditions

(Note 4)

Operating Junction Temperature Range	-----	-40°C to +125°C
Operating Ambient Temperature Range	-----	-40°C to +85°C
Supply Input Voltage, V_{IN}	-----	+8V to 32V

Note 1. Stresses listed as the above *Absolute Maximum Ratings* may cause permanent damage to the device. These are for stress ratings. Functional operation of the device at these or any other conditions beyond those indicated in the operational sections of the specifications is not implied. Exposure to absolute maximum rating conditions for extended periods may remain possibility to affect device reliability.

Note 2. Devices are ESD sensitive. Handling precaution recommended.

Note 3. θ_{JA} is measured in the natural convection at $T_A = 25^\circ\text{C}$ on a low effective thermal conductivity test board of JEDEC 51-3 thermal measurement standard.

Note 4. The device is not guaranteed to function outside its operating conditions.

Electrical Characteristics

 ($V_{IN} = 12V$, $T_A = 25^\circ C$, unless otherwise specified)

Parameter	Symbol	Test Conditions	Min	Typ	Max	Units
Supply Input Voltage						
Input Voltage Range	V_{IN}		8	--	32	V
VIN POR Threshold		VIN rising	--	7.5	--	V
		VIN falling	--	7.0	--	
Supply Input Current						
Input OVP Threshold	V_{IN_OVP}	VIN_OVP rising	32.5	--	--	V
		VIN_OVP falling	32.2	--	--	
Input Quiescent Current	I_Q	No switching	--	1	1.5	mA
Power Switches						
Hi-Side Switch On Resistance	$R_{DS(ON)}$		--	90	--	mΩ
Low-Side Switch On Resistance	$R_{DS(ON)}$		--	90	--	mΩ
Oscillator						
Oscillation Frequency	f_{OSC}		--	135	--	kHz
Maximum Duty Cycle	D_{MAX}		95	97	--	%
Output Voltage						
Output Voltage Accuracy	ΔV_{OUT}	$V_{IN} = 12V$, $V_{OUT} = 5.1V$	-1.5	--	+1.5	%
Soft Start						
Soft Start Time	T_{SS}		--	12	--	ms
Enable/Cable Compensation						
EN/COMP Logic Low	$R_{EN/COMP}$	$R_{EN/COMP}$ falling	--	--	14	kΩ
Current Sense Amplifier						
Difference Voltage Between SENSE+ and SENSE- at CC Mode Operation	ΔV_{SEN}	$V_{OUT} = 5.1V$	126.1	130	133.9	mV
Protection						
CC (Constant Output Current) Limit	I_{OUT}	$R_{SENSE} = 50m\Omega$, $V_{OUT} = 5.1V$	2.53	2.6	2.67	A
		$R_{SENSE} = 43.33m\Omega$, $V_{OUT} = 5.1V$	--	3	--	
Output Voltage Needs to Collapse Threshold	V_{OUT}	Into CC (Constant Output Current) Limit	--	3.25	--	V
Output Over Voltage Protection	V_{OVP}	$V_{OUT} = 5.1V$, measured at V_{SENSE-}	--	10	--	%
Thermal Shutdown Temperature	T_{SD}		--	150	--	°C
Thermal Shutdown Hysteresis	T_{SDHYS}		--	20	--	°C

Typical Operation Characteristics

Power On Waveforms

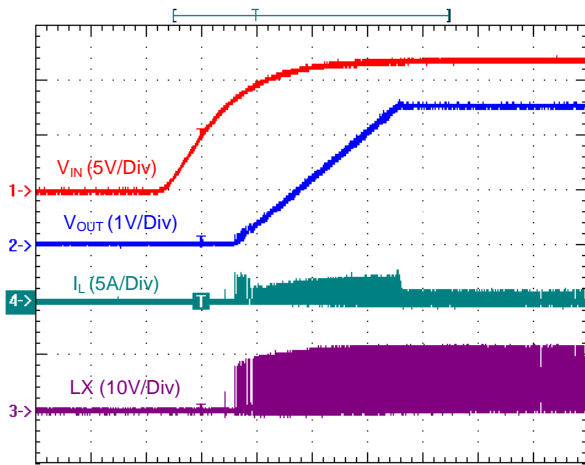

Time : 4ms/Div
 $V_{IN} = 12V, V_{OUT} = 5.1V, I_{OUT} = 0A$

Power Off Waveforms

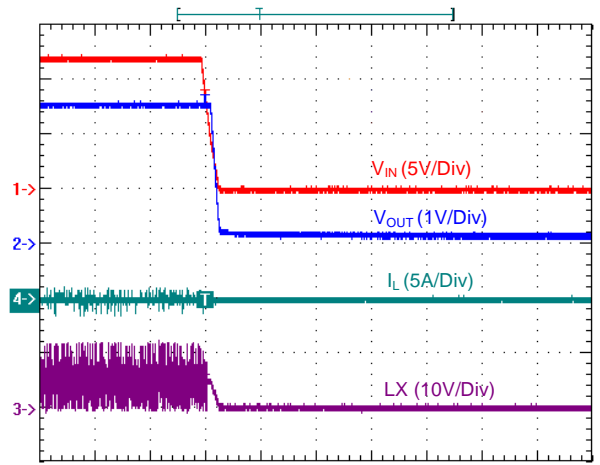

Time : 400ms/Div
 $V_{IN} = 12V, V_{OUT} = 5.1V, I_{OUT} = 0A$

Power On Waveforms

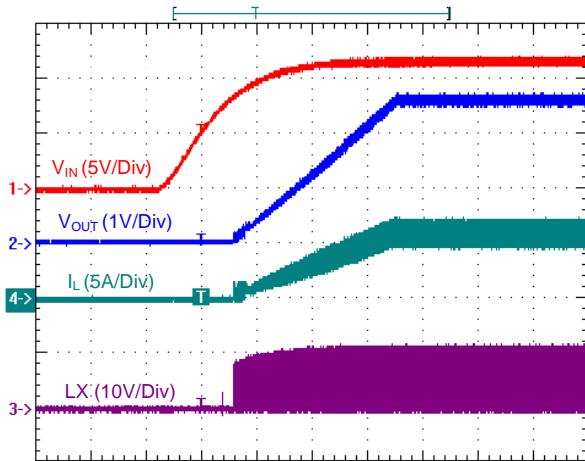

Time : 4ms/Div
 $V_{IN} = 12V, V_{OUT} = 5.1V, I_{OUT} = 2.4A$

Power Off Waveforms

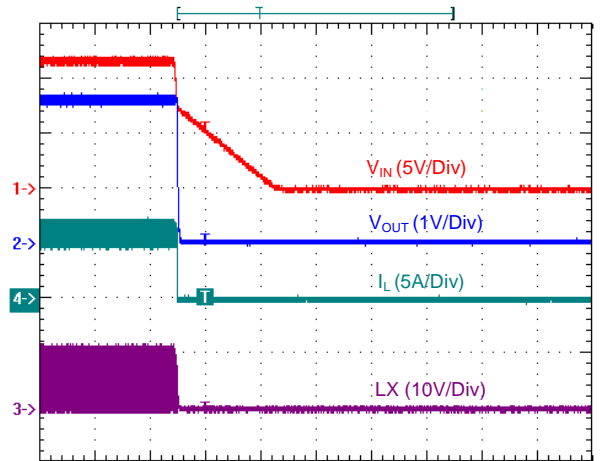

Time : 40ms/Div
 $V_{IN} = 12V, V_{OUT} = 5.1V, I_{OUT} = 2.4A$

Output Short Circuit Protection

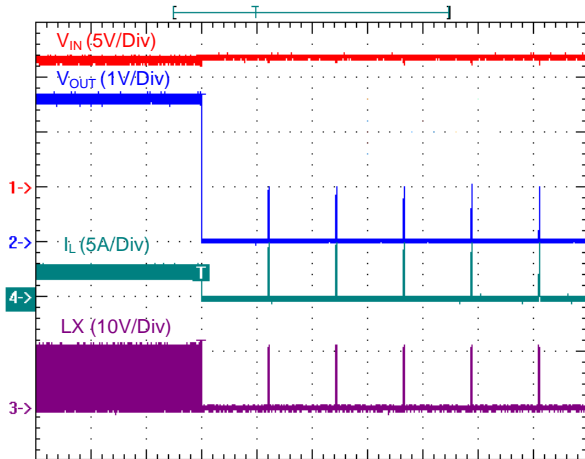

Time : 400ms/Div
 $V_{IN} = 12V, V_{OUT} = 5.1V, I_{OUT} = 2.4A$

Output Short Circuit Protection Recover

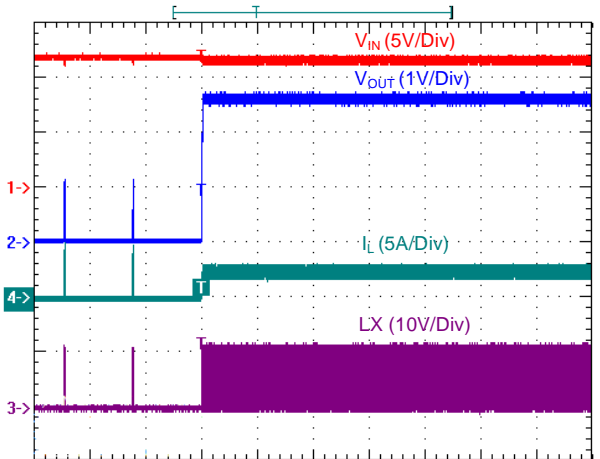

Time : 400ms/Div
 $V_{IN} = 12V, V_{OUT} = 5.1V, I_{OUT} = 2.4A$

PSOP - 8L

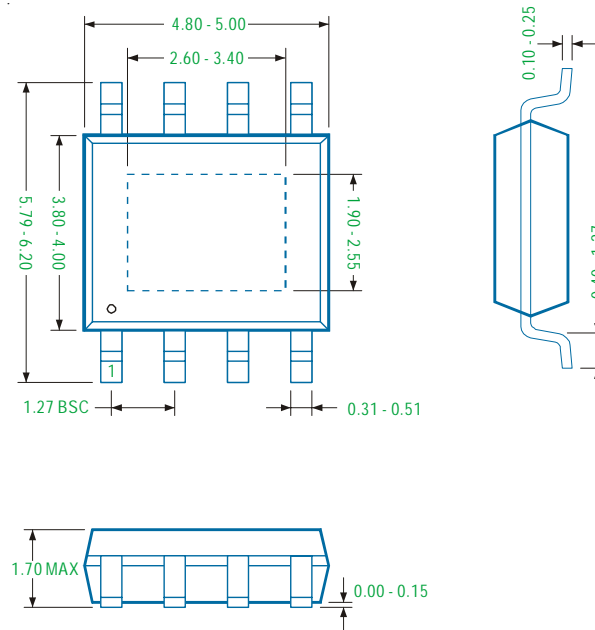

Note

1. Package Outline Unit Description:

BSC: Basic. Represents theoretical exact dimension or dimension target

MIN: Minimum dimension specified.

MAX: Maximum dimension specified.

REF: Reference. Represents dimension for reference use only. This value is not a device specification.

TYP: Typical. Provided as a general value. This value is not a device specification.

2. Dimensions in Millimeters.

3. Drawing not to scale.

4. These dimensions do not include mold flash or protrusions. Mold flash or protrusions shall not exceed 0.15mm.

Important Notice

uPI and its subsidiaries reserve the right to make corrections, modifications, enhancements, improvements, and other changes to its products and services at any time and to discontinue any product or service without notice. Customers should obtain the latest relevant information before placing orders and should verify that such information is current and complete.

uPI products are sold subject to the terms and conditions of sale supplied at the time of order acknowledgment. However, no responsibility is assumed by uPI or its subsidiaries for its use or application of any product or circuit; nor for any infringements of patents or other rights of third parties which may result from its use or application, including but not limited to any consequential or incidental damages. No uPI components are designed, intended or authorized for use in military, aerospace, automotive applications nor in systems for surgical implantation or life-sustaining. No license is granted by implication or otherwise under any patent or patent rights of uPI or its subsidiaries.

COPYRIGHT (c) 2017, UPI SEMICONDUCTOR CORP.

uPI Semiconductor Corp.

Headquarter
9F., No.5, Taiyuan 1st St. Zhubei City,
Hsinchu Taiwan, R.O.C.
TEL : 886.3.560.1666 FAX : 886.3.560.1888

Sales Branch Office
12F-5, No. 408, Ruiguang Rd. Neihu District,
Taipei Taiwan, R.O.C.
TEL : 886.2.8751.2062 FAX : 886.2.8751.5064