

3.3A Charger Interface, Wide Input Sensorless CC/CV Synchronous-Rectified Buck Converter



Qualcomm
Quick Charge 3.0

for QC2.0/QC3.0/PE+1.1/PE+2.0 And FCP

General Description

The uP9616Q is a high-efficiency synchronous-rectified buck converter with an internal power switch. With internal low RDS(ON) switches, the high-efficiency buck converter is capable of delivering up to 3.3A output current for charger interface and a wide input voltage range from 8V to 32V. It operates in either CV (Constant Output Voltage) mode or CC (Constant Output Current) mode and provides a current limitation function. The uP9616Q has a constant output voltage 5.2V/9V/12V for Qualcomm® Quick Charge™ 3.0/2.0(QC2.0/QC3.0) that is detected from D+ and D- line and automatically detects whether a connected Powered Device (PD) is Quick Charge (QC2.0/QC3.0) capable before enabling output voltage adjustment. If a PD not compliant to Quick Charge (QC2.0/QC3.0) is detected, the uP9616Q disables output voltage adjustment to ensure safe operation with legacy 5.2V only USB PDs.

uP9616Q is a USB secondary side fast-charging converter, supporting Qualcomm® Quick Charge™ 3.0 (QC 3.0) High Voltage Dedicated Charging Port (HVDCP) Class A specification.

uP9616Q allows for selection of the output voltage of an AC/DC USB adapter based on commands from the Portable Device (PD) being powered. Selecting a higher charging voltage will reduce the charging current for a given power level resulting in reduced IR drops and increased system efficiency. Another advantage of QC3.0 is a decreased battery charging time and a reduced PD system cost thanks to the ability to select an optimum charging voltage. This eliminates the need for costly DC/DC converters within the PD. The USB-bus voltage can be controlled in discreet steps from 3.6 V up to 12.1V. The output current is limited not to exceed maximum allowable power level.

Other features for the buck converter include internal soft-start, adjustable external CC (Constant Output Current) limit setting, built-in fixed line-compensation, short circuit protection, VIN/VOU over voltage protection, and over temperature protection. It is available in a space-saving VDFN6x5-8L package.

Applications

- PDA Like Device Car Chargers
- Portable Charging Devices

Ordering Information

Order Number	Package Type	Top Marking
uP9616QDC8	VDFN6x5-8L	uP9616Q

Note:

- (1) Please check the sample/production availability with uPI representatives.
- (2) uPI products are compatible with the current IPC/JEDEC J-STD-020 requirement. They are halogen-free, RoHS compliant and 100% matte tin (Sn) plating that are suitable for use in SnPb or Pb-free soldering processes.

Pin Configuration

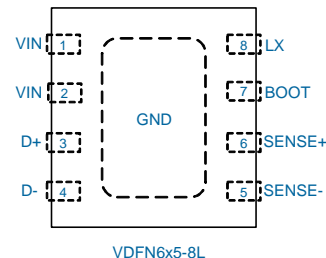

专业从事集成电路
设计、开发与销售

深圳市芯派科技有限公司
台湾芯派科技股份有限公司



唐云 职位: 销售经理
手机: 13530452646

深圳公司
地址: 深圳市宝安区西乡大道丰和园大厦2楼
电话: 0755-33653783 传真: 0755-23321161
邮箱: tangyun@sinpie.cn QQ: 2944353362
官网: www.sinpie.cn

台湾总部
地址: 新竹科学园区笃行路8-6
邮箱: R&D@siipower.com
官网: www.siipower.com

Features

- Certification: uP9616Q is certified by Qualcomm® and UL. Please refer to the information below for verification:
 - Qualcomm Quick Charge is a product of Qualcomm Technologies, Inc.
 - UL Certificate No. 47876554328-2 for uP9616 Series
 - <http://www.qualcomm.com/documents/quick-charge-device-list>
- Wide Input Voltage Range : 8V to 32V
- Input Voltage Absolute Maximum Rating: 36V
- Up to 3.3A Output Current
- CV/CC Mode Control (Constant Voltage and Constant Current)
- Supports USB DCP Shorting D+ Line to D- Line Per USB Battery Charging Specification BC 1.2
- Supports USB DCP Applying 2.7V on D+ Line and 2.7V on D- Line
- Supports USB DCP Applying 1.2V on D+ Line and D- Line
- Compliant with Apple® and Samsung Devices
- Internal QC2.0/QC3.0/PE+1.1/PE+2.0/FCP Protocol
- Wide Output Voltage Range: 3.6V to 12.1V
- Output Voltage Accuracy: $\pm 2\%$
- Fixed 125kHz Frequency Operation
- Up to 95% Conversion Efficiency
- Fixed Cable Compensation Voltage
- Adjustable External CC (Constant Output Current) Limit Setting: Default = 3.3A
- CC (Constant Output Current) Limit Accuracy: $\pm 3\%$
- Short Circuit Protection
- VIN/VOUT Over Voltage Protection and Over Temperature Protections
- VDFN6x5-8L Package
- RoHS Compliant and Halogen Free

Typical Application Circuit

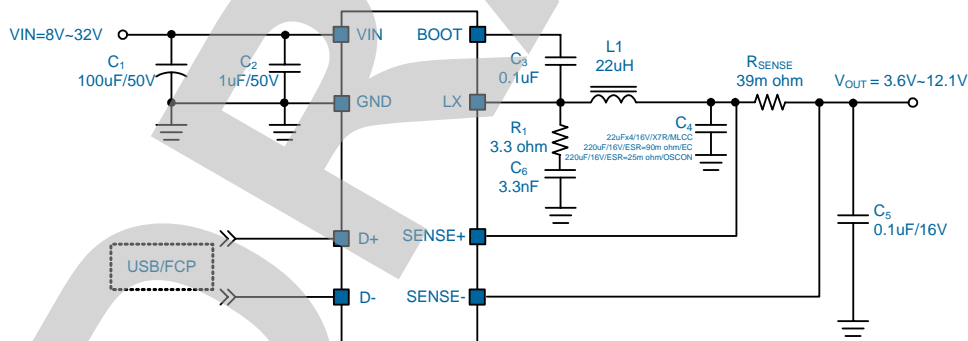



专业从事集成电路
设计、开发与销售

深圳市芯派科技有限公司

台湾芯派科技股份有限公司



唐云 职位: 销售经理
手机: 13530452646

深圳公司
地址: 深圳市宝安区西乡大道丰和园大厦2楼
电话: 0755-33653783 传真: 0755-23321161
邮箱: tangyun@sinpie.cn QQ: 2944353362
官网: www.sinpie.cn

台湾总部
地址: 新竹科学园区笃行路8-6
邮箱: R&D@siipower.com
官网: www.siipower.com

Functional Pin Description

Pin No.	Pin Name	Pin Function
PDC8		
1,2	VIN	Power Supply Input. Input voltage that supplies current to the output voltage and powers the internal control circuit. Bypass the input voltage with a minimum 1uF x1 X5R or X7R ceramic capacitor.
3	D+	USB Port D+ Input Connection. USB D+ data line input.
4	D-	USB Port D- Input Connection. USB D- data line input.
5	SENSE-	The Current Sense Input (-) Pin. Adjustable line and cable compensation voltage.
6	SENSE+	The Current Sense Input (+) Pin. Adjustable line and cable compensation voltage.
7	BOOT	Bootstrap Supply for the Floating Upper Gate Driver. Connect the bootstrap capacitor C BOOT between BOOT pin and the LX pin to form a bootstrap circuit. The bootstrap capacitor provides the charge to turn on the upper MOSFET. Typical value for C BOOT is 0.1uF or greater. Ensure that C BOOT is placed near the IC.
8	LX	Internal Switches Output. Connect this pin to the output inductor.
Exposed Pad (GND)		Ground. Ground of the buck converter. The exposed pad is the main path for heat convection and should be well-soldered to the PCB for best thermal performance.



芯派科技

专业从事集成电路
设计、开发与销售

深圳市芯派科技有限公司

台湾芯派科技股份有限公司



唐云

职位：销售经理
手机：13530452646

深圳公司
地址：深圳市宝安区西乡大道丰和园大厦2楼
电话：0755-33653783 传真：0755-23321161
邮箱：tangyun@sinpie.cn QQ: 2944353362
官网：www.sinpie.cn

台湾总部
地址：新竹科学园区笃行路8-6
邮箱：R&D@siipower.com
官网：www.siipower.com

Functional Block Diagram

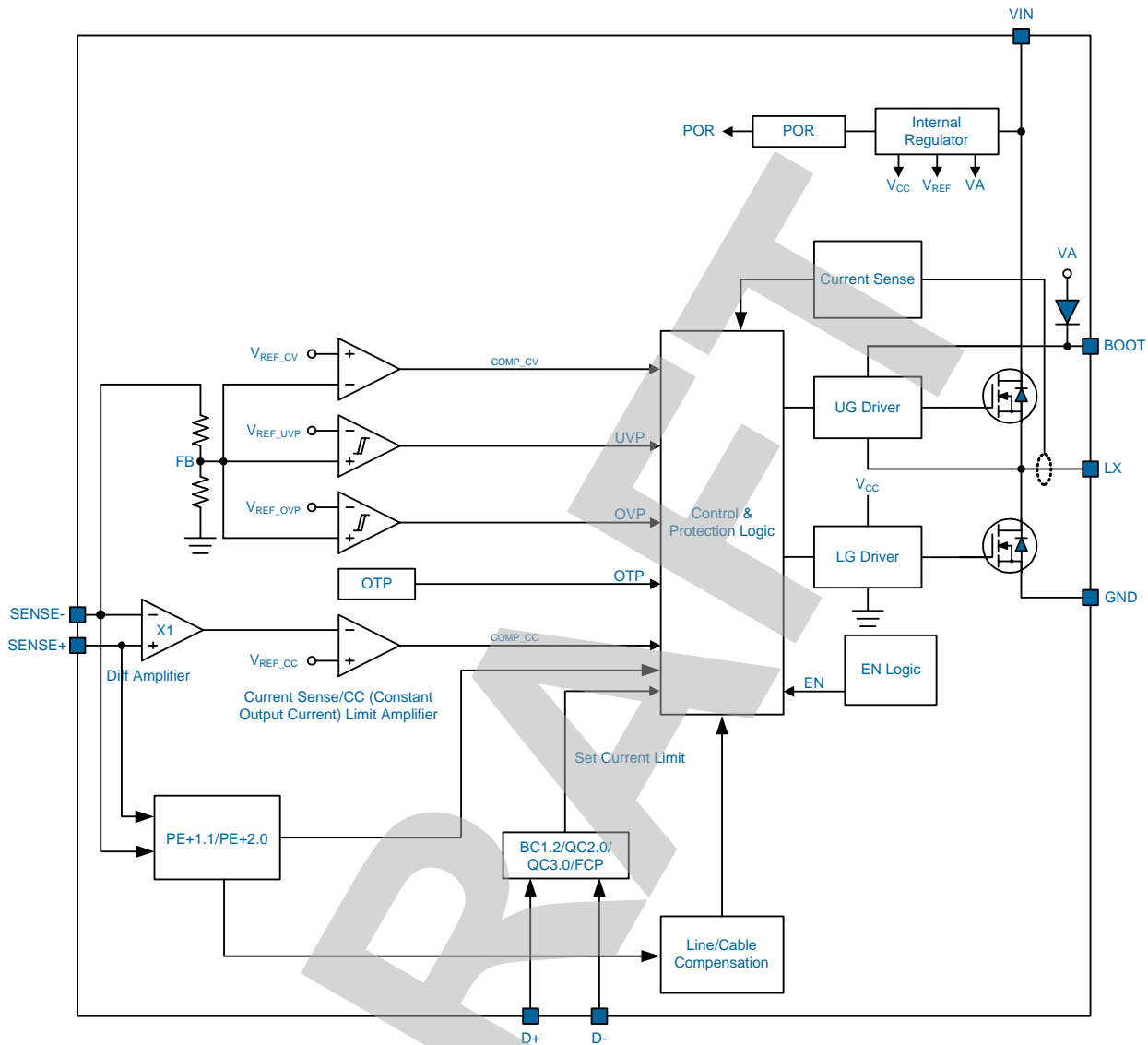

Functional Description

CV/CC Mode Control

The uP9616Q provides CV/CC function. It operates in either CV (Constant Output Voltage) mode or CC (Constant Output Current) mode. The function provides a current limitation function and adjusts external current limit setting (Default=3.3A). In the CV mode, the output voltage is controlled within ±1.5%. In the CC mode, the output current variation is less than ±3% of the nominal value which can be set up to 3.3A by the current sensing resistor. When Output current increase until it reaches the CC limit set by the R_{SENSE} resistor. At this point, the device will transition from regulating output voltage to regulating output current, and the output voltage will drop with increasing load.

The CC (Constant Output Current) limit is set at 3.3A by default with an external resistance $R_{SENSE} = 39m\Omega$, When the (SENSE1+) - (SENSE1-) voltage gets higher than 130mV and reaches the current limit, the driver is turned off. The CC (Constant Output Current) limit is set according to the following equation:

$$CC \text{ (Constant Output Current) Limit} = \frac{130mV}{R_{SENSE}}$$

Output Cable Resistance Compensation

In charger applications, the large load will cause voltage drop in the output cable. The uP9616Q has a built-in cable compensation function. When the load increases, the cable compensator will increase an adjustable regulation of the error amplifier that can make the output voltage constant. Use the curve and table to adjust internal the reference voltage values for fixed USB cable compensation by outside resistance $R_{SENSE} = 39m\Omega$ (default), as shown in Figure 1 and Table 1. The fixed cable compensation is calculated as follows:

$$V_{COMP} = I_{LOAD} \times R_{COMP}$$

$R_{COMP} (m\Omega)$	60
$I_{LOAD} (mA)$	Fixed USB Cable Compensation Voltage (mV)
0	0
500	0
1000	60
1500	90
2000	120
2500	150
3000	180

Table 1 USB Cable Compensation Application Table

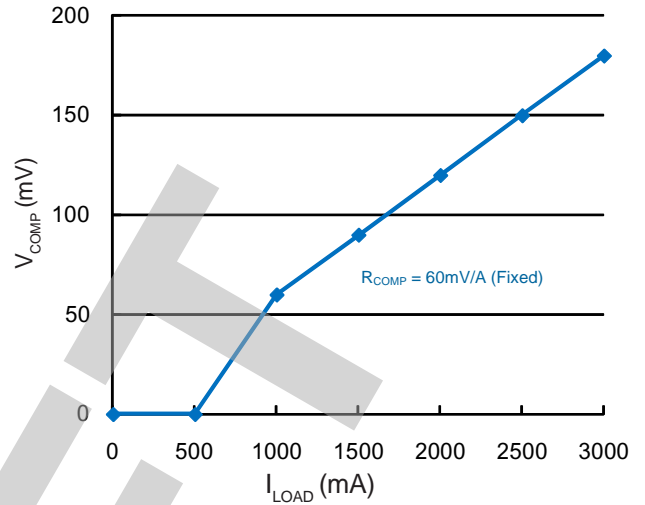

Figure 1 USB Cable Compensation at a Fixed Resistor Divider Value

Current Limit Protection

The uP9616Q continuously monitors the inductor current, when the inductor current is higher than current limit threshold, the current limit function activates and forces the upper switch turning off to limit inductor current cycle by cycle.

Output Short Circuit Protection

The uP9616Q provides output short circuit protection function. Once the output loader short-circuits, the SCP will be triggered then always hiccup, the hiccup cycle time is set by an internal counter. When the SCP condition is removed or disappears, the converter will resume normal operation and the hiccup status will terminate.

Output Over Voltage Protection

The uP9616Q provides output over voltage protection. Once the output voltage (measured the at SENSE- pin) gets higher than OVP threshold, the OVP will be triggered to shut down the converter. When the OVP condition disappears, the converter will resume normal operation and resume the normal state automatically.

Over Temperature Protection

The OTP is triggered and shuts down the uP9616Q if the junction temperature is higher than 150°C The OTP is a non-latch type protection. The uP9616Q automatically initiates another soft start cycle if the junction temperature drops below 130°C.

Functional Description

High Voltage Dedicated Charging Port (HVDCP) Mode

After power-up pins D+ and D- of uP9616Q are shorted with impedance R_{DCP_DAT} and internal reference voltage V_{REF} is set to V_{BUS} voltage 5.2V. The device is in a BC1.2 compatible mode. If a portable device compatible with the Qualcomm Quick Charge specification is connected, a negotiation between HVDCP and PD is executed. Once the negotiation is successful the uP9616Q opens D+ and D- short connection and D- is pulled down with a R_{DM_DWN} . The uP9616Q enters HVDCP mode. It monitors D+ and D- inputs. Based on the specified control patterns, the internal voltage reference value V_{REF} is adjusted in order to increase or decrease output voltage to the required value.

The uP9616Q is available in Class A version. Class A allows to change the output voltage up to $V_{BUS} = 12V$. If the unplug event is detected the decoder circuitry turns-on an internal current sink, which discharges the output capacitors to a safe voltage level. If the uP9616Q is set to a Continuous mode it responds to the PD requests in a Single request mode. It does not support Group request mode.

HVDCP Continuous Mode

The continuous mode of operation leverages the previously unused state in QC2.0. If the portable devices try and utilize this mode, it applies voltages on D+ and D- per Table 2. Assuming the HVDCP supports this mode of operation, it will glitch filter the request as it currently does, using TGLITCH_V_CHANGE(40ms). Before the portable device can begin to increment or decrement the voltage, it must wait TV_NEW_REQUEST_CONT before pulling D+ and D-high or low. Once this time has finished, the portable device now attempts to increment or decrement the voltage. To increment, the portable device sends a pulse of width TACTIVE by pulling D+ to VDP_UP and then must return D+ to VDP_SRC for TINACTIVE.

Portable Device		HVDCP Class A
D+	D-	Output Voltage
0.6V	GND	5.2V
3.3V	0.6V	9V
0.6V	0.6V	12V
0.6V	3.3V	Continuous Mode
3.3	3.3	Previous Voltage

Table2. HVDCP detection voltage coding and status

Note: GND is not forced by the portable device. The portable device shall go High-Z and the HVDCP pulls D- low through R_{dm_dwn} . This is to prevent misdetection when current flowing through GND causes the GND in the portable device to be at a higher voltage relative to HVDCP GND. Care should be taken in the portable device as this can result in a negative relative voltage on D- as seen by the portable device.



Absolute Maximum Rating

(Note 1)

Supply Input Voltage, V_{IN}	-----	-0.3V to +36V
LX Voltage to GND	-----	-0.3V to + (VIN + -0.3V)
D+/D- Pin Voltage	-----	-0.3V to +6.0V
SENSE+/SENSE- Pin Voltage	-----	-0.3V to +14V
Storage Temperature Range	-----	-65°C to +150°C
Junction Temperature	-----	150°C
Lead Temperature (Soldering, 10 sec)	-----	260°C
ESD Rating (Note 2)		
D+/D-/Sense- Pin		
HBM (Human Body Mode)	-----	4kV
MM (Machine Mode)	-----	400V
Other Pins		
HBM (Human Body Mode)	-----	2kV
MM (Machine Mode)	-----	200V

Thermal Information

Package Thermal Resistance (Note 3)

VDFN6x5 - 8L θ_{JA}	-----	45°C/W
VDFN6x5 - 8L θ_{JC}	-----	4°C/W
Power Dissipation, P_D @ $T_A = 25^\circ\text{C}$		
VDFN6x5 - 8L	-----	2.2W

Recommended Operation Conditions

(Note 4)

Operating Junction Temperature Range	-----	-40°C to +125°C
Operating Ambient Temperature Range	-----	-40°C to +85°C
Supply Input Voltage, V_{IN}	-----	+8V to 32V

Note 1. Stresses listed as the above *Absolute Maximum Ratings* may cause permanent damage to the device. These are for stress ratings. Functional operation of the device at these or any other conditions beyond those indicated in the operational sections of the specifications is not implied. Exposure to absolute maximum rating conditions for extended periods may remain possibility to affect device reliability.

Note 2. Devices are ESD sensitive. Handling precaution recommended.

Note 3. θ_{JA} is measured in the natural convection at $T_A = 25^\circ\text{C}$ on a low effective thermal conductivity test board of JEDEC 51-3 thermal measurement standard.

Note 4. The device is not guaranteed to function outside its operating conditions.

Electrical Characteristics

($V_{IN} = 12V$, $T_A = 25^\circ C$, unless otherwise specified)

Parameter	Symbol	Test Conditions	Min	Typ	Max	Units
Supply Input Voltage						
Input Voltage Range	V_{IN}		8	--	32	V
VIN POR Threshold		VIN Rising	--	7.5	--	V
		VIN Falling	--	7.0	--	V
Input OVP Threshold	V_{IN_OVP}	V_{IN_OVP} Rising	32.8	--	--	V
		V_{IN_OVP} Falling	32.3	--	--	V
Supply Input Current						
Input Quiescent Current	I_{Q1}	No switching	--	1	1.50	mA
Power Switches						
Hi-Side Switch On Resistance	$R_{DS(ON)}$		--	80	--	m Ω
Low-Side Switch On Resistance	$R_{DS(ON)}$		--	50	--	m Ω
Oscillation Frequency	f_{OSC}		--	125	--	kHz
Maximum Duty Cycle	D_{MAX}		96	98	99	%
Output Voltage and Soft Start						
Output Voltage Accuracy	ΔV_{OUT}	$V_{IN} = 12V, V_{OUT} = 5.2V$, only for C2.0/QC3.0/FCP	-2	--	+2	%
		$V_{IN} = 12V, V_{OUT} = 9V$, only for QC2.0/QC3.0	-2	--	+2	
		$V_{IN} = 12V, V_{OUT} = 9.2V$, only for FCP	-2	--	+2	
		$V_{IN} = 24V, V_{OUT} = 12V$, only for QC2.0/QC3.0	-2	--	+2	
		$V_{IN} = 24V, V_{OUT} = 12.1V$, only for FCP	-2	--	+2	
Soft Start Time	T_{SS}		--	10	--	ms
Current Sense Amplifier						
Voltage Difference Between SENSE+ and SENSE- at CC Mode Operation	ΔV_{SEN}	$V_{OUT} = 5.2V$	127	130	133	mV
Output Cable Resistance Compensation						
Fixed Line Compensation	V_{OUT}	$V_{OUT} = 5.2V, I_O = 2.5A$ measured at V_{SENSE}	110	150	190	mV
Protection						
CC (Constant Output Current) Limit	I_{OUT}	$R_{SENSE} = 39m\Omega, V_{OUT} = 5.2V$	3.256	3.33	3.410	A
Output Voltage needs to collapse threshold	V_{OUT}	Into CC (Constant Output Current) Limit. Only for QC2.0/3.0 and MTK	2.850	3.100	3.350	V
Output Over Voltage Protection	V_{OVP}	measured at V_{SENSE-}	--	10	--	%
Output Under Voltage Protection	V_{UVP}	$V_{OUT} = 9.2V$, only for FCP	--	6.7	--	V
		$V_{OUT} = 12.1V$, only for FCP	--	10	--	

Electrical Characteristics

Parameter	Symbol	Test Conditions	Min	Typ	Max	Units
Protection (Cont.)						
Thermal Shutdown Temperature	T_{SD}		--	150	--	°C
Thermal Shutdown Hysteresis	T_{SDHYS}		--	20	--	°C
High Voltage Dedicated Charging Port (D+/D-)						
Data Detect Voltage	V_{DAT_REF}		0.25	0.325	0.40	V
Output Voltage Selection Reference	V_{SEL_REF}	2.0V Reference for Selection HVDCP Voltage	1.80	2	2.20	V
Current Limit for HVDCP at Any Output Voltage	I_{HVDCP_MIN}	All HVDCP's must output this current at minimum	500	--	--	mA
D- Low Glitch Filter Time	$T_{GLITCHP_DM_LOW}$	After D+/- A are open and Rdm_dwn is asserted, how long should HVDCP expect D- to stay low before being pulled high.	1	--	--	ms
D- High Glitch Filter Time	$T_{GLITCHP_DM_HIGH}$	After D+/- A are open and Rdm_dwn is asserted, how long after a portable device sees D- go low, before it makes first voltage request and pulls D-high.	40	--	--	ms
D+ High Glitch Filter Time	$T_{GLITCHP_BC_Done}$	After BC1.2 Detection is complete, HVDCP	1	--	1.50	s
Output Voltage Glitch Filter Time	$T_{GLITCHP_V_CHANGE}$	Glitch filter after D+/- toggle before HVDCP attempts to change output voltage	20	40	60	ms
Unplug Vbus Discharge	T_{V_UNPLUG}	Time for Vbus to discharge to 5.2V in HVDCP on unplug	--	--	500	ms
D+/D- HVDCP Short Time	T_{D+D-_SHORT}	Time for D+/D- to short on HVDCP	--	10	20	ms
D+D- Capacitance	C_{DCP_PWR}	Equivalent capacitance on D+ and D- to GND	--	--	1	nF
Data Line Leakage	R_{DAT_LKG}		300	--	1500	kΩ
D- Pull Down Resistance	R_{D_DWN}		12	15	18	kΩ
BC 1.2 DCP Mode (Short Mode)						
D+ to D- Resistance During DCP Mode	R_{DCP_DAT}		--	20	40	Ω
D+ Output Voltage	$V_{DP_1.2V+}$	VIN = 12V	1.12	1.20	1.28	V
D- Output Voltage	$V_{DM_1.2V+}$	VIN = 12V	1.12	1.20	1.28	V
D+ Output Impedance	$R_{DP_1.2V}$	ID+ = -5uA	80	102	130	kΩ
D- Output Impedance	$V_{DM_1.2V+}$	ID- = -5uA	80	102	130	kΩ
Divider Mode (2.7V/2.7V)						
D+ Output Voltage	$V_{D+_2.7V}$	VIN = 12V	2.57	2.70	2.84	V
D- Output Voltage	$V_{D-_2.7V}$	VIN = 12V	2.57	2.70	2.84	V
D+ Output Impedance	$R_{D+_2.7V}$	ID+ = -5uA	--	36	--	kΩ
D- Output Impedance	$R_{D-_2.7V}$	ID- = -5uA	--	36	--	kΩ

This page is intentionally left blank and will be updated when data is available.

DRAFT

Output Inductor Selection

Output inductor selection is usually based on the considerations of inductance, rated current value, size requirements and DC resistance (DCR).

The inductance is chosen based on the desired ripple current. Large value inductors result in lower ripple currents and small value inductors result in higher ripple currents. Higher V_{IN} or V_{OUT} also increases the ripple current as shown in the equation below. A reasonable starting point for setting ripple current is $\Delta I_L = 900\text{mA}$ (30% of 3000mA).

$$\Delta I_L = \frac{1}{f_{OSC} \times L_{OUT}} \times V_{OUT} \left(1 - \frac{V_{OUT}}{V_{IN}}\right)$$

Maximum current ratings of the inductor are generally specified in two methods: permissible DC current and saturation current. Permissible DC current is the allowable DC current that causes 40°C temperature raise. The saturation current is the allowable current that causes 10% inductance loss. Make sure that the inductor will not saturate over the operation conditions including temperature range, input voltage range, and maximum output current. If possible, choose an inductor with rated current higher than 5A so that it will not saturate even under current limit condition.

The size requirements refer to the area and height requirement for a particular design. For better efficiency, choose a low DC resistance inductor. DCR is usually inversely proportional to size.

Different core materials and shapes will change the size, current and price/current relationship of an inductor. Toroid or shielded pot cores in ferrite or permalloy materials are small and don't radiate much energy, but generally cost more than powdered iron core inductors with similar electrical characteristics. The choice of which style inductor to use often depends on the price vs. size requirements and any radiated field/EMI requirements.

Input Capacitor Selection

The input capacitor needs to be carefully selected to maintain sufficiently low ripple at the supply input of the converter. A low ESR capacitor is highly recommended. Since large current flows in and out of this capacitor during switching, its ESR also affects efficiency.

The input capacitance needs to be higher than 22uF. The best choice is the ceramic type and low ESR electrolytic types may also be used provided that the RMS ripple current rating is higher than 50% of the output current. In the case of the electrolytic types, they can be further away if a small parallel 1uF ceramic capacitor is placed right close to the IC. A 100uF electrolytic capacitor and 1uF ceramic capacitor are recommended and placed close to VIN and GND pins, with the shortest traces possible.

Output Capacitor Selection

The ESR of the output capacitor determines the output ripple voltage and the initial voltage drop following a high slew rate load transient edge. The output ripple voltage can be calculated as:

$$\Delta V_{OUT} = \Delta I_C \times \left(\text{ESR} + \frac{1}{8 \times f_{OSC} \times C_{OUT}} \right)$$

Where f_{OSC} = operating frequency, C_{OUT} = output capacitance and $\Delta I_C = \Delta I_L$ = ripple current in the inductor. The ceramic capacitor with low ESR value provides the low output ripple and low size profile.

In the case of electrolytic capacitors, the ripple is dominated by R_{ESR} multiplied by the ripple current. Connect a 220uF electrolytic capacitor at output SENSE+ terminal for good performance and low output ripple and place output capacitor as close as possible to the device.

In the case of ceramic output capacitors, R_{ESR} is very small and does not contribute to the output ripple. Connect a 0.1uF ceramic capacitor at output SENSE- terminal for good performance and place output capacitors as close as possible to the device.

PCB Layout Consideration

The PCB layout is an important step to maintain the high performance of the uP9616Q. High switching frequencies and relatively large peak currents make the PCB layout a very important part of all high frequency switching power supply design. Both the high current and the fast switching nodes demand full attention to the PCB layout to save the robustness of the uP9616Q through the PCB layout. Improper layout might show the symptoms of poor load or lineregulation, radiate excessive noise at ground or input, output voltage shifts, stability issues, unsatisfying EMI behavior or worsened efficiency. Follow the PCB layout guidelines for optimal performances of uP9616Q.

Layout Guidelines For uP9616QDC8:

1. Arrange the power components to reduce the AC loop size consisting of C_{IN} , VIN (Pin 1, 2) and LX (Pin 8)
2. The input decoupling ceramic capacitor 1 μ F must be placed closest to the VIN (Pin 1, 2) and Exposed Pad GND plane through vias or a short and wide path.
3. Return SENSE+ (PIN 6) to signal GND pin, and connect the signal GND to power GND at a single point for best noise immunity. Connect exposed pad to power ground opper area with copper and vias.
4. Apply copper plane to Exposed Pad GND for best heat dissipation and noise immunity. The exposed pad is the main path for heat convection and should be well-soldered to the PCB for best thermal performance.
5. Use a short trace connecting the bootstrap capacitor C_{BOOT} to BOOT (Pin 7) and LX (Pin 8) to form a bootstrap circuit.
6. Use a short trace connecting R-C to LX (Pin 8) and Exposed Pad GND Plane to form a Snubber Circuit.
7. The LX (Pin 8) pad is the noise node switching from VIN (Pin 1, 2) to GND. LX node copper area should be minimized to reduce EMI and should be isolated from the rest of circuit for good EMI and low noise operation.
8. The D+ (Pin 3) pad and D- (Pin 4) pad of the uP9616Q are the USB detect data line input node, the D+ and D- Pin of the via or trace area should be isolated using 0.96mm space to prevent direct contact with VIN area components which may cause voltage of D+ and D- pins to exceed maximum rating of 6V.

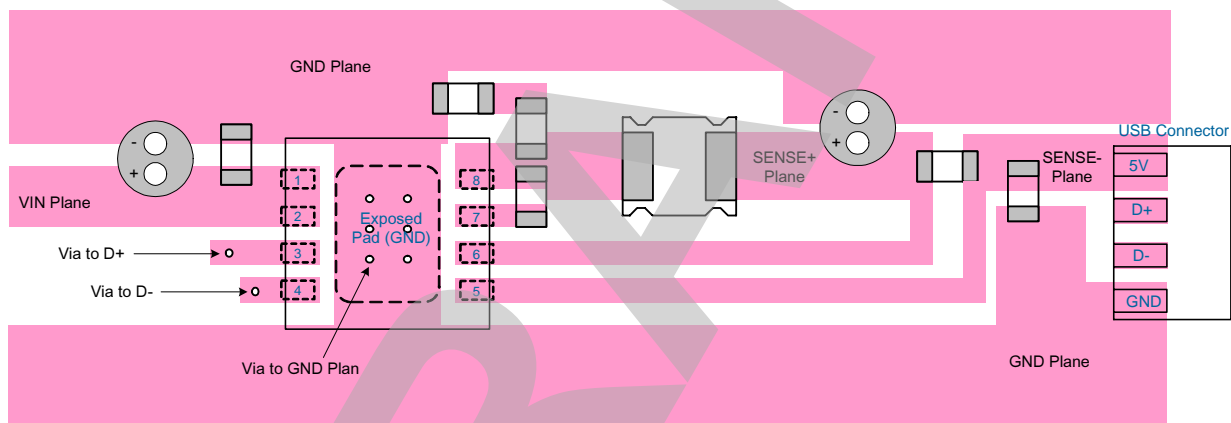

uP9616QDC8

VDFN6x5 - 8L

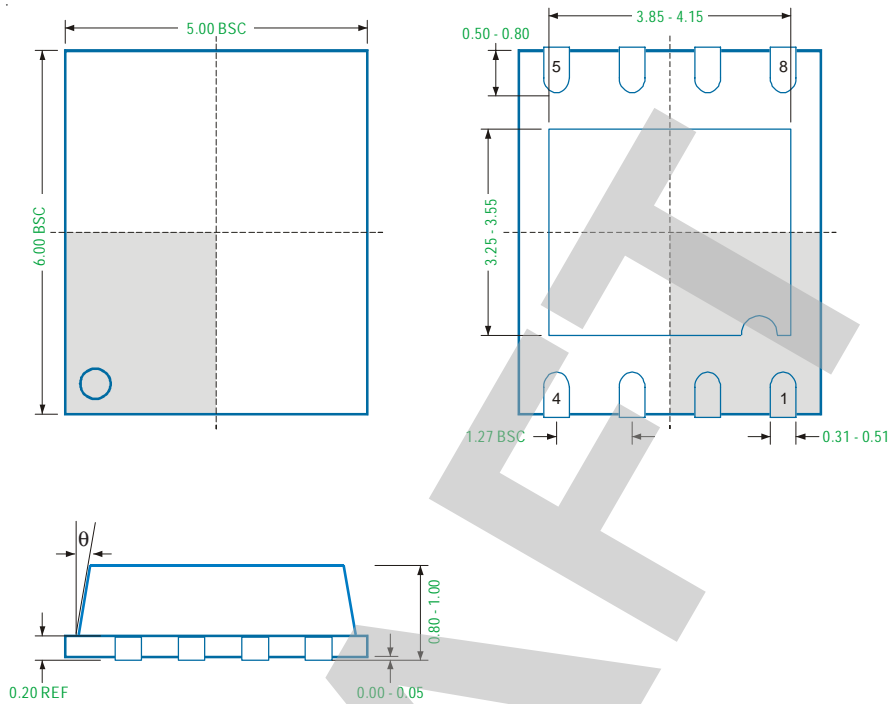

Note

1. Package Outline Unit Description:

BSC: Basic. Represents theoretical exact dimension or dimension target

MIN: Minimum dimension specified.

MAX: Maximum dimension specified.

REF: Reference. Represents dimension for reference use only. This value is not a device specification.

TYP: Typical. Provided as a general value. This value is not a device specification.

2. Dimensions in Millimeters.

3. Drawing not to scale.

4. These dimensions do not include mold flash or protrusions. Mold flash or protrusions shall not exceed 0.15mm.

Important Notice

uPI and its subsidiaries reserve the right to make corrections, modifications, enhancements, improvements, and other changes to its products and services at any time and to discontinue any product or service without notice. Customers should obtain the latest relevant information before placing orders and should verify that such information is current and complete.

uPI products are sold subject to the terms and conditions of sale supplied at the time of order acknowledgment. However, no responsibility is assumed by uPI or its subsidiaries for its use or application of any product or circuit; nor for any infringements of patents or other rights of third parties which may result from its use or application, including but not limited to any consequential or incidental damages. No uPI components are designed, intended or authorized for use in military, aerospace, automotive applications nor in systems for surgical implantation or life-sustaining. No license is granted by implication or otherwise under any patent or patent rights of uPI or its subsidiaries.

COPYRIGHT (c) 2016, UPI SEMICONDUCTOR CORP.

DRAFT

uPI Semiconductor Corp.

Headquarter
9F.,No.5, Taiyuan 1st St. Zhubei City,
Hsinchu Taiwan, R.O.C.
TEL : 886.3.560.1666 FAX : 886.3.560.1888

Sales Branch Office
12F-5, No. 408, Ruiguang Rd. Neihu District,
Taipei Taiwan, R.O.C.
TEL : 886.2.8751.2062 FAX : 886.2.8751.5064