

# MOS FIELD EFFECT TRANSISTOR $\mu$ PA2757GR

## SWITCHING N-CHANNEL POWER MOS FET

### DESCRIPTION

The  $\mu$ PA2757GR is Dual N-channel MOS Field Effect Transistors designed for switching application.

### FEATURES

- Low on-state resistance  
 $R_{DS(on)1} = 36.0 \text{ m}\Omega \text{ MAX.}$  ( $V_{GS} = 10 \text{ V}$ ,  $I_D = 3.0 \text{ A}$ )  
 $R_{DS(on)2} = 50.0 \text{ m}\Omega \text{ MAX.}$  ( $V_{GS} = 4.5 \text{ V}$ ,  $I_D = 3.0 \text{ A}$ )
- Low gate charge  
 $Q_G = 10 \text{ nC TYP.}$  ( $V_{GS} = 10 \text{ V}$ )
- Built-in G-S protection diode
- Small and surface mount package (Power SOP8)

### PACKAGE DRAWING (Unit: mm)

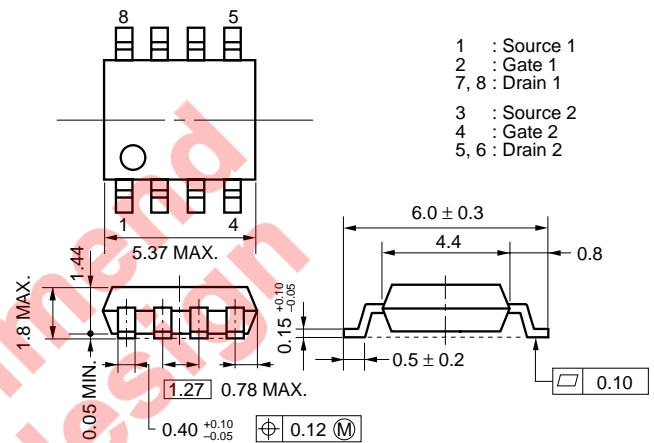

### ORDERING INFORMATION

PART NUMBER	LEAD PLATING	PACKING	PACKAGE
$\mu$ PA2757GR-E1-AT <small>Note</small>	Pure Sn	Tape 2500	Power SOP8
$\mu$ PA2757GR-E2-AT <small>Note</small>		p/reel	

**Note** Pb-free (This product does not contain Pb in the external electrode and other parts.)

### EQUIVALENT CIRCUIT

(1/2 circuit)

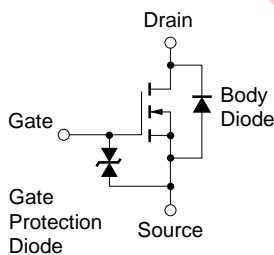

**Remark** The diode connected between the gate and source of the transistor serves as a protector against ESD. When this device actually used, an additional protection circuit is externally required if a voltage exceeding the rated voltage may be applied to this device.

**Caution** This product is electrostatic-sensitive device due to low ESD capability and should be handled with caution for electrostatic discharge.  $V_{ESD} \pm 600 \text{ V TYP.}$  ( $C = 100 \text{ pF}$ ,  $R = 1.5 \text{ k}\Omega$ )

The information in this document is subject to change without notice. Before using this document, please confirm that this is the latest version.  
 Not all products and/or types are available in every country. Please check with an NEC Electronics sales representative for availability and additional information.

**ABSOLUTE MAXIMUM RATINGS (T<sub>A</sub> = 25°C)**

	Drain to Source Voltage (V <sub>GS</sub> = 0 V)	V <sub>DSS</sub>	30	V
	Gate to Source Voltage (V <sub>DS</sub> = 0 V)	V <sub>GSS</sub>	±20	V
	Drain Current (DC) (T <sub>C</sub> = 25°C) <sup>Note2</sup>	I <sub>D(DC)</sub>	±5.0	A
	Drain Current (pulse) <sup>Note1</sup>	I <sub>D(pulse)</sub>	±20	A
	Total Power Dissipation (1 unit) <sup>Note2</sup>	P <sub>T1</sub>	1.7	W
	Total Power Dissipation (2 units) <sup>Note2</sup>	P <sub>T2</sub>	2.0	W
	Channel Temperature	T <sub>ch</sub>	150	°C
	Storage Temperature	T <sub>stg</sub>	-55 to +150	°C
<R>	Single Avalanche Current <sup>Note3</sup>	I <sub>AS</sub>	5	A
<R>	Single Avalanche Energy <sup>Note3</sup>	E <sub>AS</sub>	2.5	mJ

**Notes** 1. PW ≤ 10 μs, Duty Cycle ≤ 1%

2. Mounted on ceramic substrate of 2000 mm<sup>2</sup> × 1.6 mmt

<R> 3. Starting T<sub>ch</sub> = 25°C, V<sub>DD</sub> = 15 V, R<sub>G</sub> = 25 Ω, V<sub>GS</sub> = 20 → 0 V

Not recommend  
for new design

**ELECTRICAL CHARACTERISTICS (TA = 25°C. All terminals are connected.)**

CHARACTERISTICS	SYMBOL	TEST CONDITIONS	MIN.	TYP.	MAX.	UNIT
Zero Gate Voltage Drain Current	$I_{DSS}$	$V_{DS} = 30\text{ V}, V_{GS} = 0\text{ V}$			10	μA
Gate Leakage Current	$I_{GSS}$	$V_{GS} = \pm 16\text{ V}, V_{DS} = 0\text{ V}$			±10	μA
Gate to Source Cut-off Voltage	$V_{GS(off)}$	$V_{DS} = 10\text{ V}, I_D = 1\text{ mA}$	1.0		2.5	V
Forward Transfer Admittance <sup>Note</sup>	$ y_{fs} $	$V_{DS} = 10\text{ V}, I_D = 3\text{ A}$	2.0			S
Drain to Source On-state Resistance <sup>Note</sup>	$R_{DS(on)1}$	$V_{GS} = 10\text{ V}, I_D = 3.0\text{ A}$		28.5	36.0	mΩ
	$R_{DS(on)2}$	$V_{GS} = 4.5\text{ V}, I_D = 3.0\text{ A}$		36.0	50.0	mΩ
Input Capacitance	$C_{iss}$	$V_{DS} = 10\text{ V},$		400		pF
Output Capacitance	$C_{oss}$	$V_{GS} = 0\text{ V},$		80		pF
Reverse Transfer Capacitance	$C_{rss}$	$f = 1\text{ MHz}$		50		pF
Turn-on Delay Time	$t_{d(on)}$	$V_{DD} = 15\text{ V}, I_D = 3\text{ A},$		7		ns
Rise Time	$t_r$	$V_{GS} = 10\text{ V},$		4		ns
Turn-off Delay Time	$t_{d(off)}$	$R_G = 10\ \Omega$		21		ns
Fall Time	$t_f$			5		ns
Total Gate Charge	$Q_G$	$I_D = 5\text{ A},$		10		nC
Gate to Source Charge	$Q_{GS}$	$V_{DD} = 24\text{ V},$		1.5		nC
Gate to Drain Charge	$Q_{GD}$	$V_{GS} = 10\text{ V}$		2.7		nC
Body Diode Forward Voltage <sup>Note</sup>	$V_{F(S-D)}$	$I_F = 5\text{ A}, V_{GS} = 0\text{ V}$		0.86		V
Reverse Recovery Time	$t_{rr}$	$I_F = 5\text{ A}, V_{GS} = 0\text{ V},$		20		ns
Reverse Recovery Charge	$Q_{rr}$	$di/dt = 50\text{ A}/\mu\text{s}$		16		nC

Note Pulsed

<R> TEST CIRCUIT 1 AVALANCHE CAPABILITY

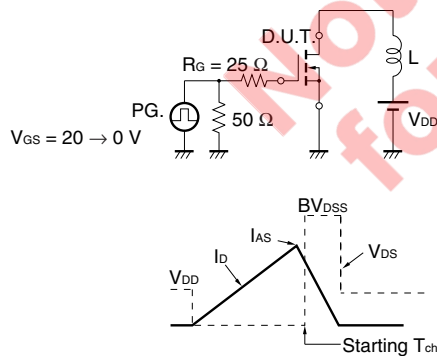

TEST CIRCUIT 2 SWITCHING TIME

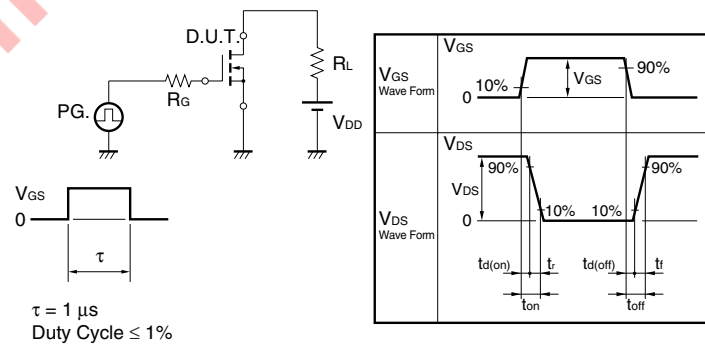

TEST CIRCUIT 3 GATE CHARGE

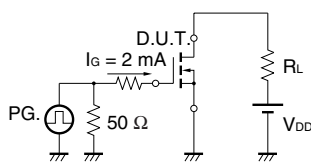

TYPICAL CHARACTERISTICS (T<sub>A</sub> = 25°C)

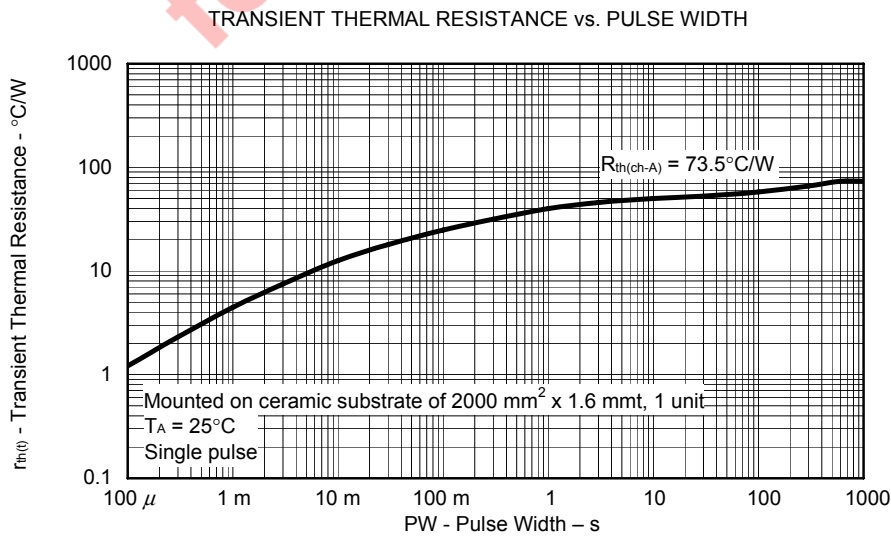
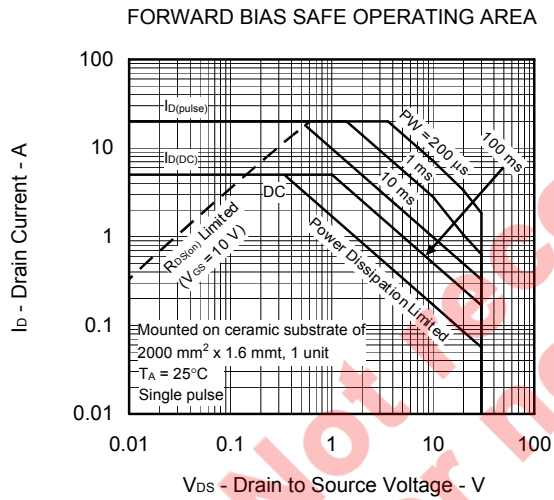
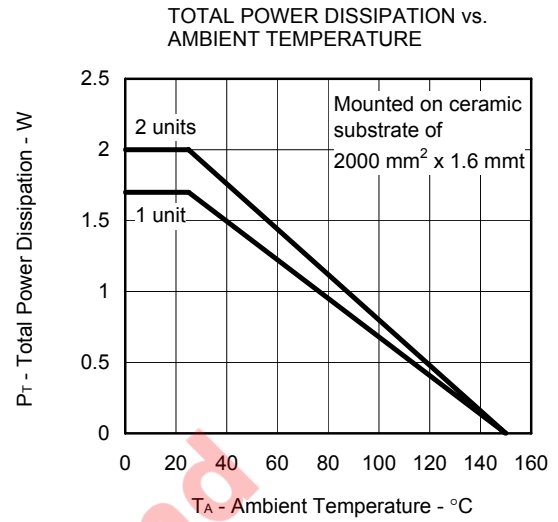
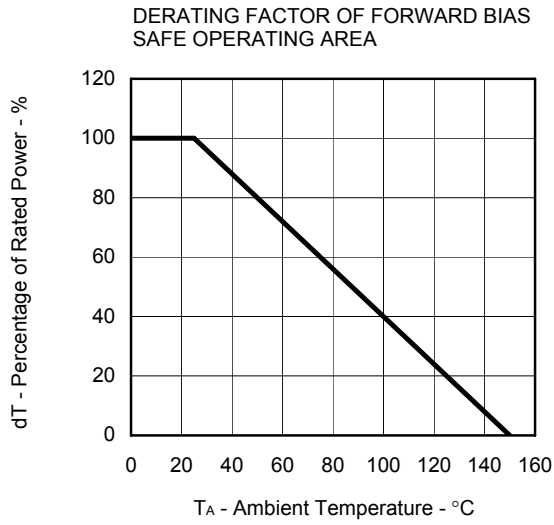

DRAIN CURRENT vs. DRAIN TO SOURCE VOLTAGE

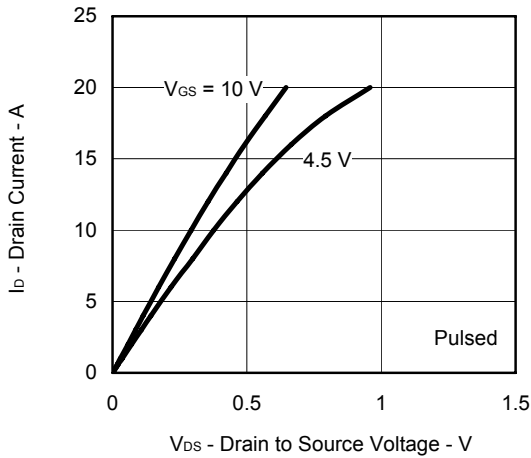

FORWARD TRANSFER CHARACTERISTICS

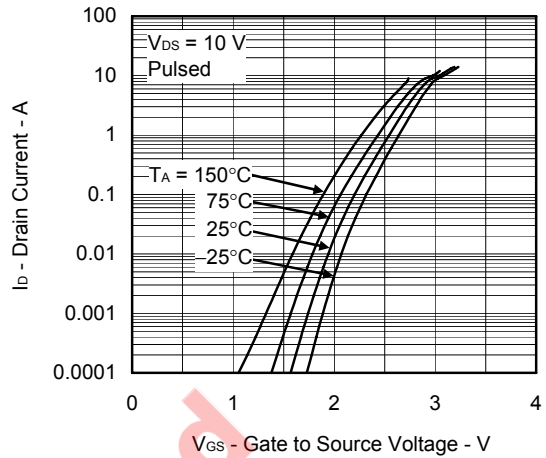

GATE TO SOURCE CUT-OFF VOLTAGE vs. CHANNEL TEMPERATURE

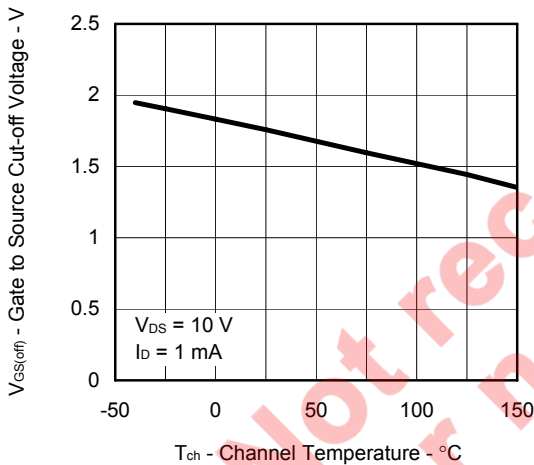

FORWARD TRANSFER ADMITTANCE vs. DRAIN CURRENT

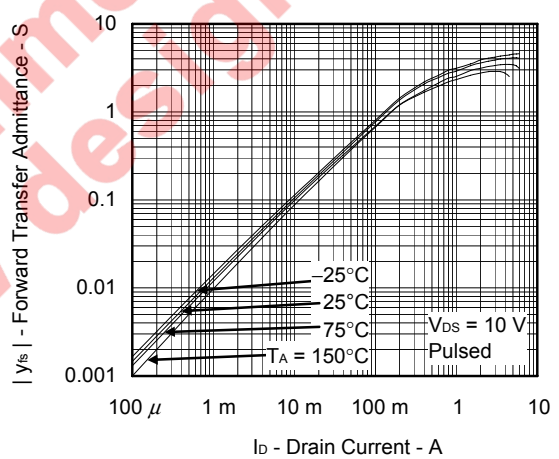

DRAIN TO SOURCE ON-STATE RESISTANCE vs. DRAIN CURRENT

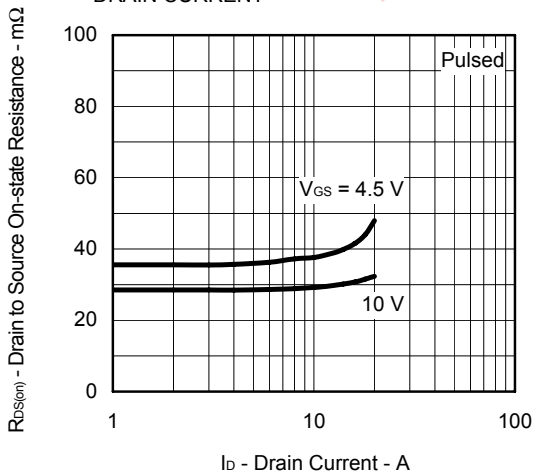

DRAIN TO SOURCE ON-STATE RESISTANCE vs. GATE TO SOURCE VOLTAGE

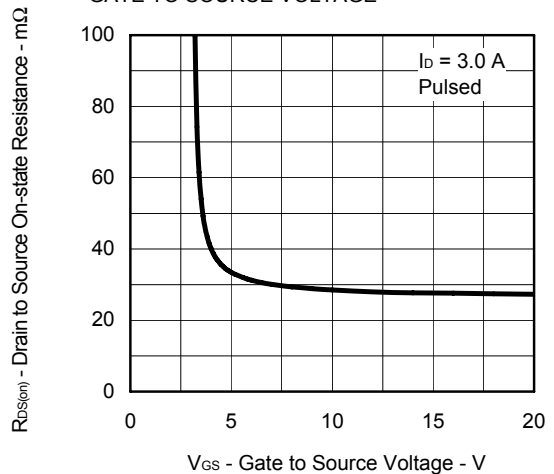

DRAIN TO SOURCE ON-STATE RESISTANCE vs. CHANNEL TEMPERATURE

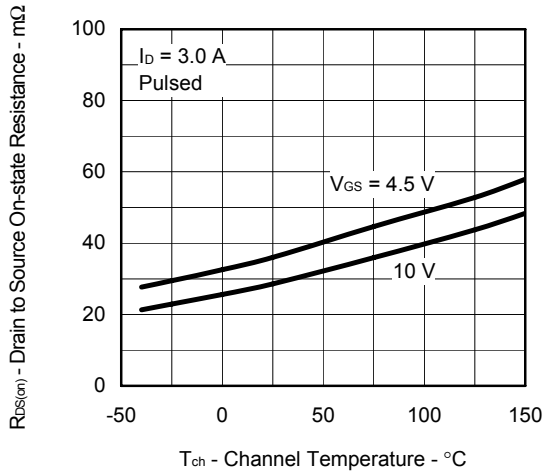

CAPACITANCE vs. DRAIN TO SOURCE VOLTAGE

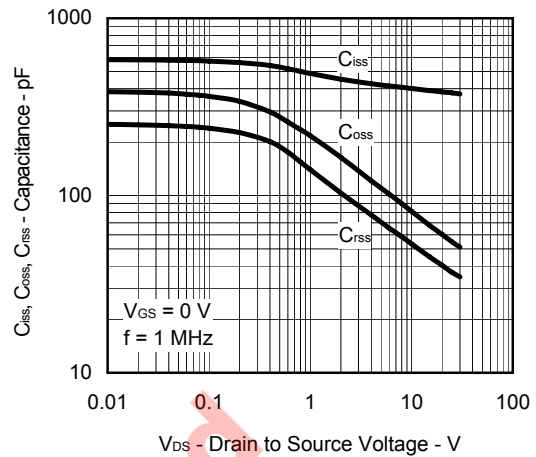

SWITCHING CHARACTERISTICS

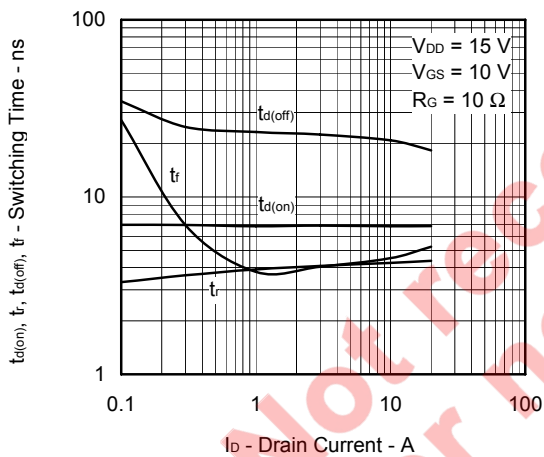

DYNAMIC INPUT/OUTPUT CHARACTERISTICS

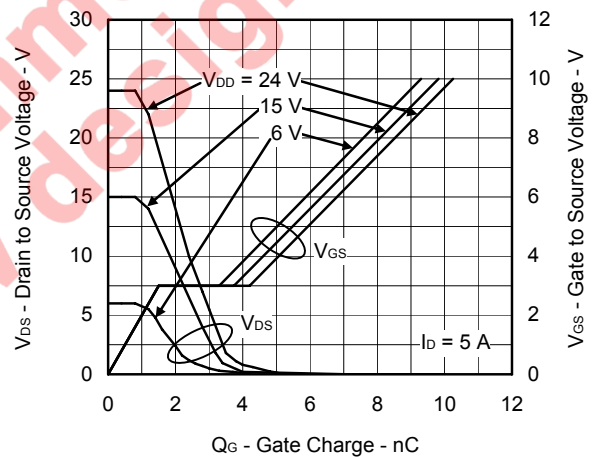

SOURCE TO DRAIN DIODE FORWARD VOLTAGE

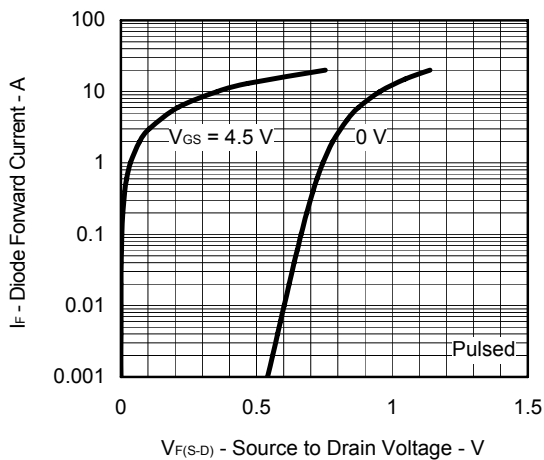

REVERSE RECOVERY TIME vs. DIODE FORWARD CURRENT

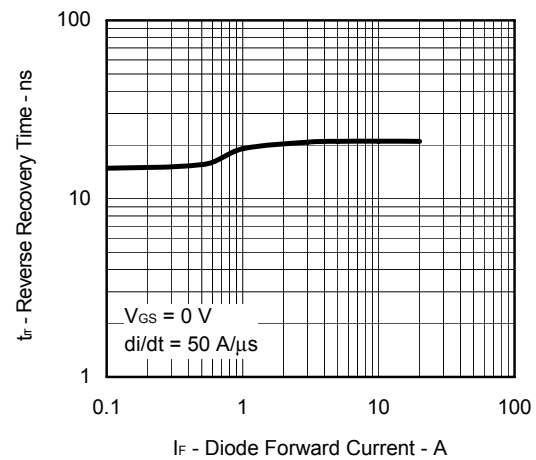

**TAPE INFORMATION**

There are two types (-E1, -E2) of taping depending on the direction of the device.

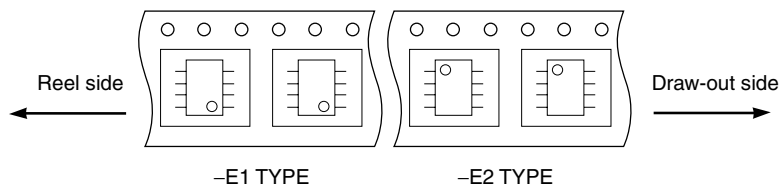

**MARKING INFORMATION**

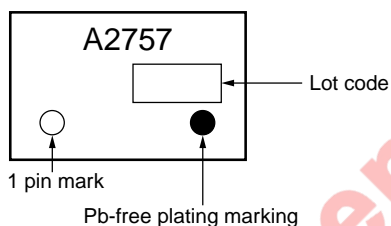

**RECOMMENDED SOLDERING CONDITIONS**

The μPA2757GR should be soldered and mounted under the following recommended conditions.

For soldering methods and conditions other than those recommended below, please contact an NEC Electronics sales representative.

For technical information, see the following website.

Semiconductor Device Mount Manual (<http://www.necel.com/pkg/en/mount/index.html>)

Soldering Method	Soldering Conditions	Recommended Condition Symbol
Infrared reflow	Maximum temperature (Package's surface temperature): 260°C or below Time at maximum temperature: 10 seconds or less Time of temperature higher than 220°C: 60 seconds or less Preheating time at 160 to 180°C: 60 to 120 seconds Maximum number of reflow processes: 3 times Maximum chlorine content of rosin flux (percentage mass): 0.2% or less	IR60-00-3
Partial heating	Maximum temperature (Pin temperature): 350°C or below Time (per side of the device): 3 seconds or less Maximum chlorine content of rosin flux: 0.2% (wt.) or less	P350

**Caution Do not use different soldering methods together (except for partial heating).**