



## THREE-PHASE SPINDLE MOTOR DRIVER FOR MONOLITHIC CD-ROM

### DESCRIPTION

The  $\mu$ PD16836 is a three-phase spindle motor driver for CD-ROM drives which consists of a CMOS control circuit and MOS bridge output. It employs a three-phase full-wave PWM driving method and a MOS FET in the output stage to lower the power consumption compared with drivers using conventional bipolar transistors.

### FEATURES

- Low ON resistance (Sum of ON resistance of top and bottom transistors)  $R_{on} = 1.2 \Omega$  (TYP.)
- Low power consumption using three-phase full-wave PWM driving system
- START/STOP pins enable braking operation in STOP mode
- Standby pin turns off internal circuitry in standby mode
- Low current consumption:  $I_{DD} = 3\text{mA}$  (MAX.),  $I_{DD(ST)} = 100 \mu\text{A}$  (MAX.)
- Internal thermal shutdown circuit
- Internal overcurrent protection circuit (can be externally set)
- Internal FG output function
- Reverse prevention circuit
- 24-pin plastic SOP (375 mil)

### ORDERING INFORMATION

Part Number	Package
$\mu$ PD16836GT	24-pin plastic SOP (375 mil)

### ABSOLUTE MAXIMUM RATINGS ( $T_A = 25^\circ\text{C}$ )

Parameter	Symbol	Conditions	Ratings	Unit
Supply voltage	$V_{DD}$		-0.5 to +7.0	V
	$V_M$		-0.5 to +15.0	V
Input voltage	$V_{IN}$		-0.5 to $V_{DD} + 0.5$	V
Instantaneous output current <sup>Note 1</sup>	$I_{OP}$	$PW \leq 5 \text{ ms}$ , Duty $\leq 40 \%$	$\pm 1.3$	A
Power dissipation <sup>Note 2</sup>	$P_T$		1.25	W
Peak junction temperature	$T_{CH(MAX)}$		150	$^\circ\text{C}$
Storage temperature range	$T_{stg}$		-55 to +150	$^\circ\text{C}$

- Notes**
1. Permissible current value per one phase, when mounted on the printed circuit board
  2. When mounted on the printed circuit board (100 mm  $\times$  100 mm  $\times$  1 mm, glass epoxy)

The information in this document is subject to change without notice.

## RECOMMENDED OPERATING RANGE

Parameter	Symbol	MIN.	TYP.	MAX.	Unit
Supply voltage	V <sub>DD</sub>	4.5		5.5	V
	V <sub>M</sub>	10.8		13.2	V
Instantaneous output current	I <sub>OP</sub>			1.0	A/phase
CL pin input voltage	V <sub>CL</sub>	0.3		1.0	V
Operating temperature range	T <sub>A</sub>	-20		75	°C

ELECTRICAL SPECIFICATIONS (Unless otherwise specified, T<sub>A</sub> = 25 °C, V<sub>DD</sub> = 5 V, V<sub>M</sub> = 12 V)

Parameter	Symbol	Conditions	MIN.	TYP.	MAX.	Unit
<Overall>						
Current consumption 1 (V <sub>DD</sub> )	I <sub>DD</sub>	STB = L		1.5	3.0	mA
Current consumption 2 (standby)	I <sub>DD (ST)</sub>	STB = H			0.1	mA
<ST/SP, REV, STB>						
High-level input voltage	V <sub>IH</sub>	ST/SP = H	0.6×V <sub>DD</sub>		V <sub>DD</sub>	V
Low-level input voltage	V <sub>IL</sub>	ST/SP = L			0.8	V
Input pull-down resistor	R <sub>IND</sub>		60	100	140	kΩ
<Control circuit>						
Triangular wave oscillation frequency	f <sub>PWM</sub>	C <sub>T</sub> = 100 pF	40	100	250	kHz
<Hole amplifier>						
In-phase input voltage range	V <sub>Hch</sub>		1.0		2.8	V
Hysteresis voltage	V <sub>Hhis</sub>			20		mV
Input bias current	I <sub>Hbias</sub>				1.0	μA
<FG output>						
IND pin high-level voltage	V <sub>FG_H</sub>	I <sub>o</sub> = -4 mA	3.5			V
IND pin low-level voltage	V <sub>FG_L</sub>	I <sub>o</sub> = +4 mA			0.5	V
<Output block>						
Output ON resistance	R <sub>ON</sub> <sup>Note</sup>	I <sub>o</sub> = 200 mA, T <sub>A</sub> = -20 to 70 °C		1.2	1.8	Ω
Output turn-ON time	t <sub>ON</sub>	R <sub>M</sub> = 5 Ω (Star connection)		1.0	2.0	μs
Output turn-OFF time	t <sub>OFF</sub>			1.0	2.0	μs
<Torque command>						
Control reference input voltage range	ECR		1.5		3.0	V
Control input voltage range	EC		1.0		3.5	V
Input current	I				100	μA
Input differential voltage	ECR-EC	Duty = 100 %		0.32		V
DEADZONE (+)	EC d+		5	75	150	mV
DEADZONE (-)	EC d-		-150	-75	-150	mV

**Note** Sum of ON resistance of top and bottom transistors

The thermal shutdown circuit operates at T<sub>CH</sub> ≥ 150 °C

The low-voltage malfunction prevention circuit (UVLO) operates at V<sub>DD</sub> = 4 V (TYP.)

**PIN CONFIGURATION**

REV	1	24	V <sub>DD</sub>
ST/SP	2	23	C <sub>T</sub>
STB	3	22	IND
V <sub>M</sub>	4	21	EC
OUT0	5	20	ECR
NC	6	19	H2+
OUT1	7	18	H2-
RF	8	17	H1+
OUT2	9	16	H1-
NC	10	15	H0+
NC	11	14	H0-
GND	12	13	C <sub>L</sub>

**PIN FUNCTIONS**

**Package: 24-pin plastic SOP (375 mil)**

Pin Number	Pin Name	I/O	Pin Functions
1	REV	I	Reverse operation input pin (reverse brake)
2	ST/SP	I	Start/stop input pin
3	STB	I	Standby operation input pin
4	V <sub>M</sub>	-	Motor block power supply voltage (12 V)
5	OUT0	O	Motor connection pin (output pin)
6	NC	-	Open pin
7	OUT1	O	Motor connection pin
8	RF	I	Sense resistor connection pin
9	OUT2	O	Motor connection pin
10	NC	-	Open pin
11	NC	-	Open pin
12	GND	-	GND pin
13	C <sub>L</sub>	I	Reference voltage input pin for overcurrent detection
14	H0-	I	Hole signal input pin
15	H0+	I	Hole signal input pin
16	H1-	I	Hole signal input pin
17	H1+	I	Hole signal input pin
18	H2-	I	Hole signal input pin
19	H2+	I	Hole signal input pin
20	ECR	I	Control reference voltage input pin
21	EC	I	Control voltage input pin
22	IND	O	Index signal output pin
23	C <sub>T</sub>	I	Capacitor connection pin for oscillator frequency setting
24	V <sub>DD</sub>	-	Control block power supply voltage input pin (5 V)

BLOCK DIAGRAM

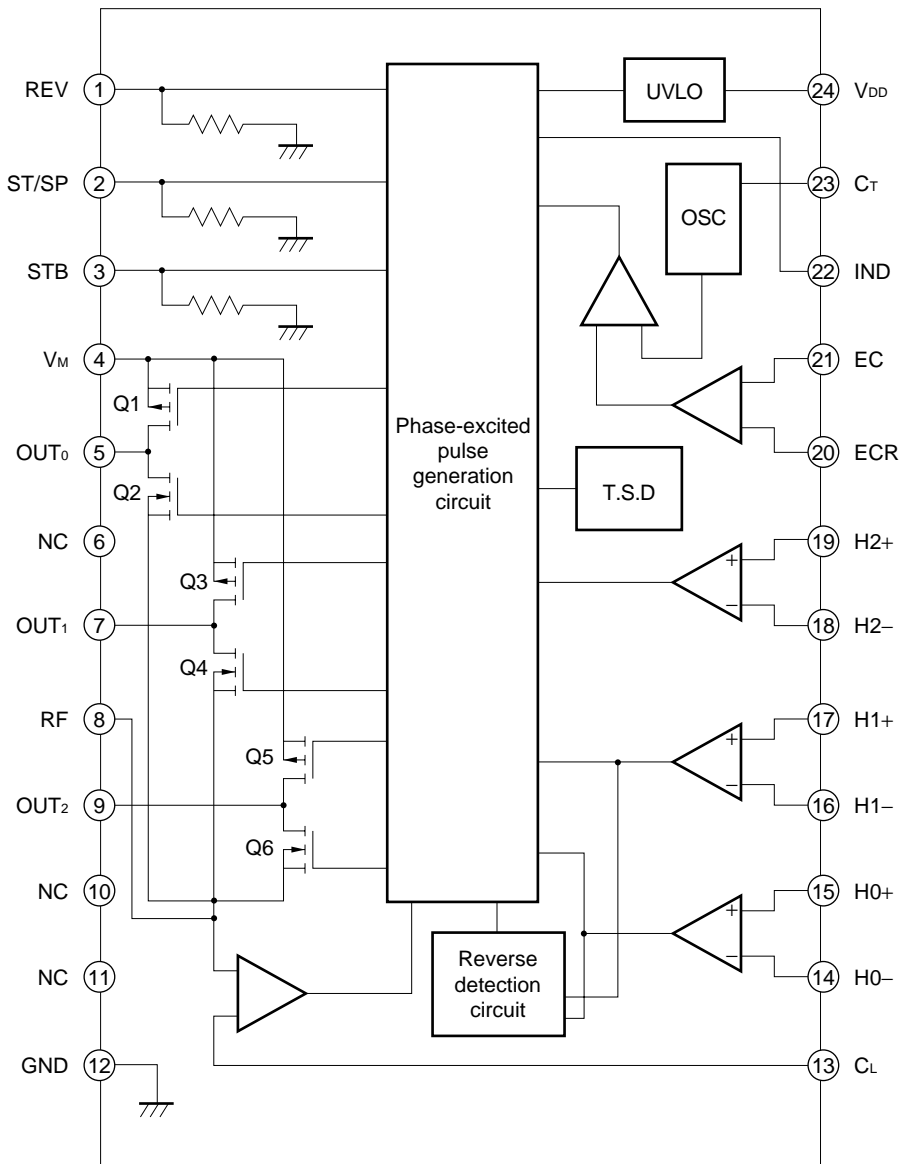

TYPICAL CHARACTERISTIC CURVES (T<sub>A</sub> = 25 °C)

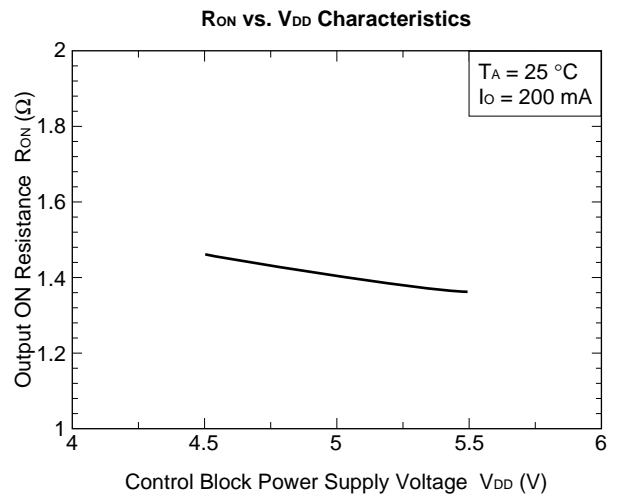
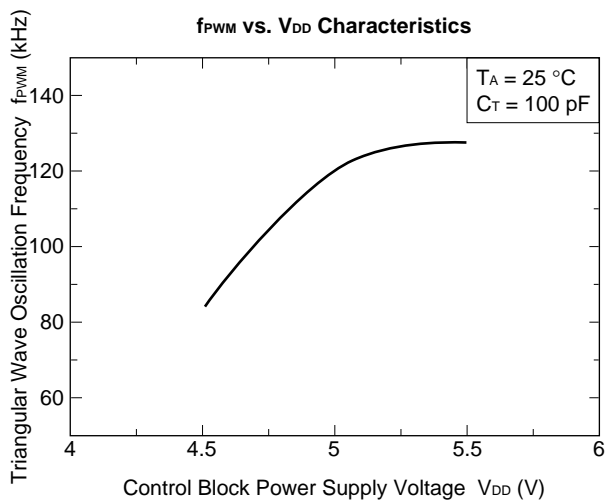
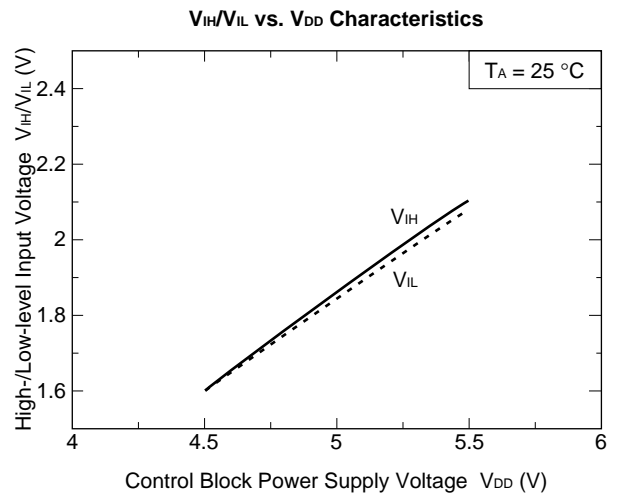
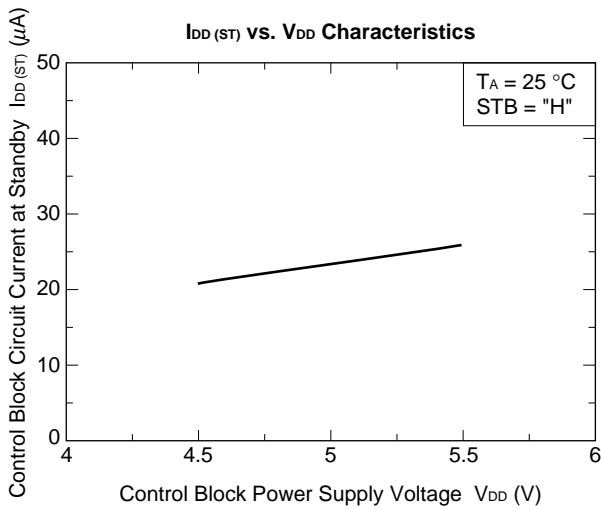
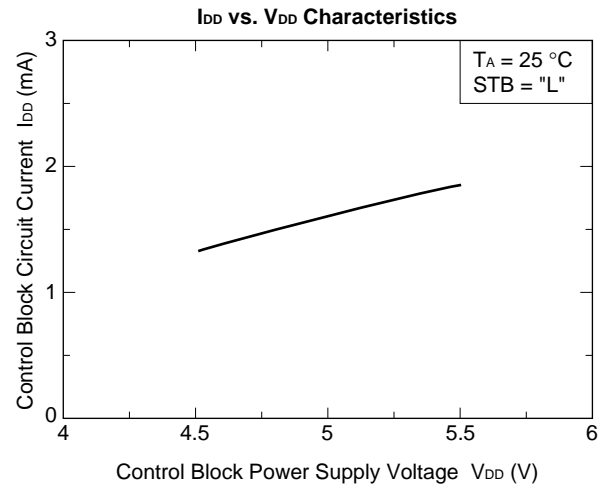
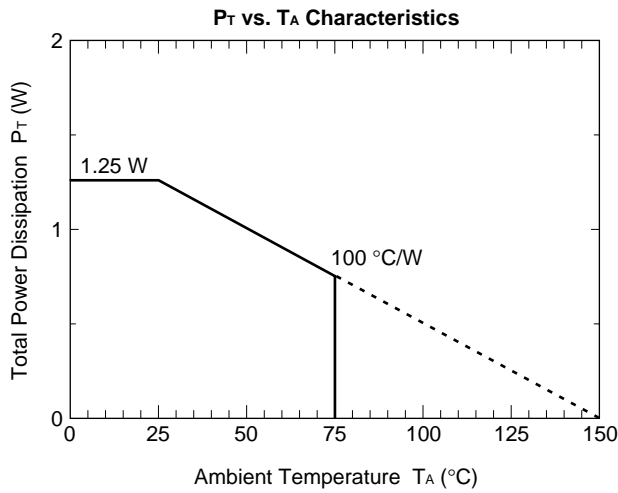

**R<sub>ON</sub> vs. T<sub>A</sub> Characteristics**

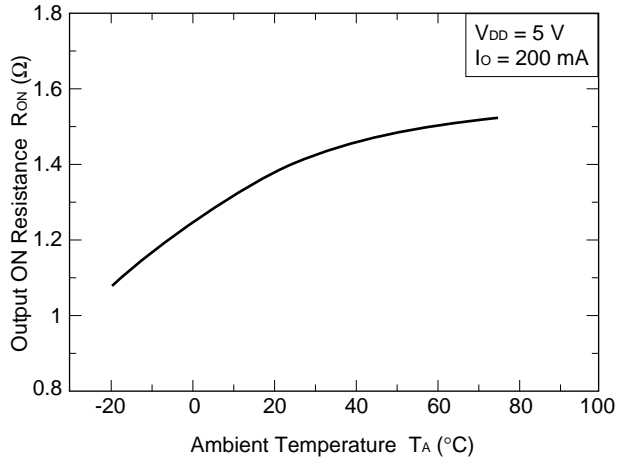

**t<sub>ON</sub>, t<sub>OFF</sub> vs. V<sub>DD</sub> Characteristics**

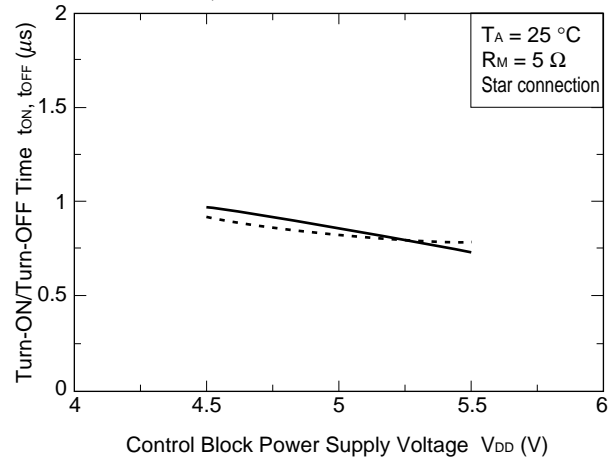

**ECR – EC vs. V<sub>DD</sub> Characteristics**

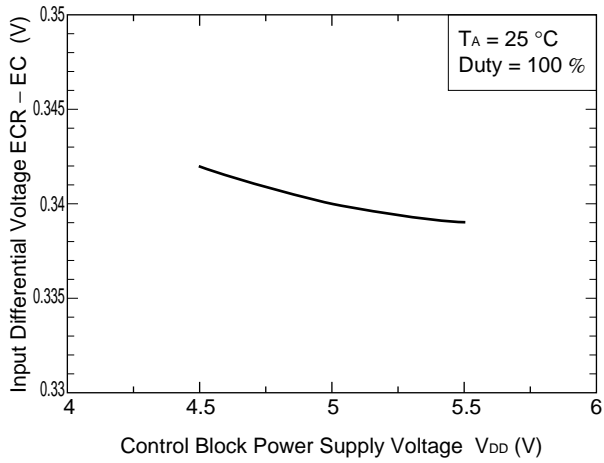

**I vs. V<sub>DD</sub> Characteristics**

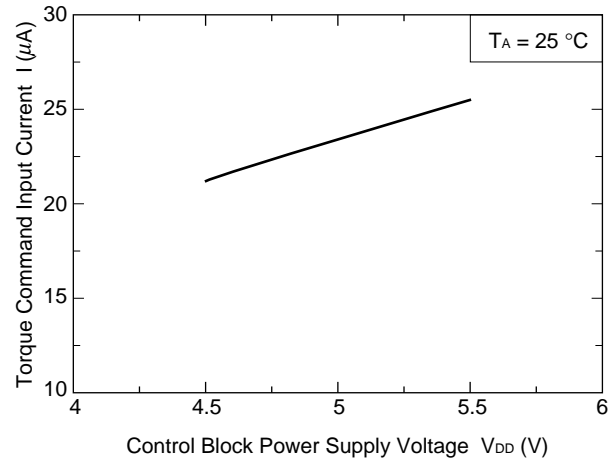

**EC d<sub>+</sub>, EC d<sub>-</sub> vs. V<sub>DD</sub> Characteristics**

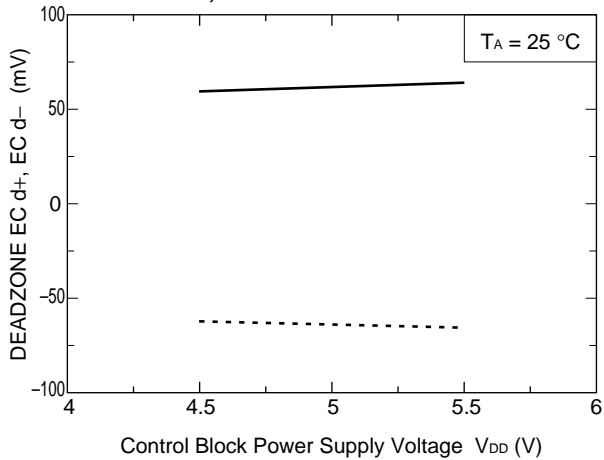

**FUNCTION OPERATION TABLE**

**(1) ST/SP = "H"**

Input Signal				Circuit Operation Mode	Source → Sink
CMP0	CMP1	CMP2	PWM		
H	H	L	H	Operation	W → V
H	H	L	L	Brake	
H	L	L	H	Operation	W → U
H	L	L	L	Brake	
H	L	H	H	Operation	V → U
H	L	H	L	Brake	
L	L	H	H	Operation	V → W
L	L	H	L	Brake	
L	H	H	H	Operation	U → W
L	H	H	L	Brake	
L	H	L	H	Operation	U → V
L	H	L	L	Brake	

Brake: For circuit operation, each high-side switch of the source and sink turns ON.

**(2) ST/SP = "L"**

Input Signal				Circuit Operation Mode
CMP0	CMP1	CMP2	PWM	
-	-	-	-	Stop

**Remark** Q1, Q3, and Q5 are ON. Q2, Q4, and Q6 are OFF.

**(3) Torque command**

The relationship between the control reference voltage (ECR) and control voltage (ECR – EC), and torque is as follows. Dead band width is 150 mV (TYP).

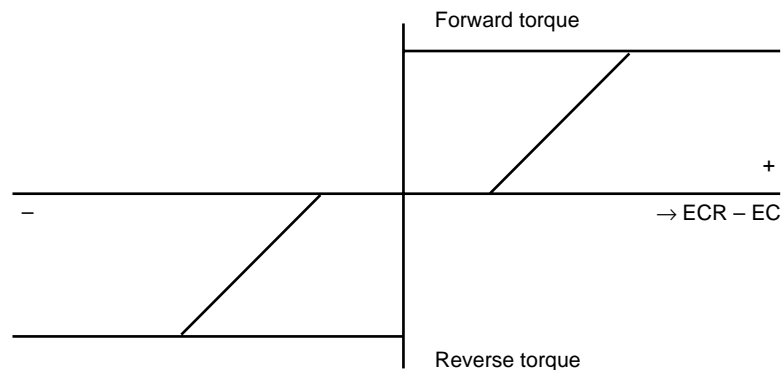

	Reverse Pin Voltage (REV)	
	L	H
$ECR > EC$	Forward	Reverse <sup>Note</sup>
$ECR < EC$	Reverse <sup>Note</sup>	Stop

**Note** Stops after detecting reverse.

**(4) Standby mode**

The internal power supply for the μPD16836 is turned off by setting the standby mode.

Each pin output is high-impedance in the standby mode. The internal oscillation block also stops, and the circuit current can be reduced.

After the normal operation mode has been set, a few of 10's of μs are necessary for the motor to restart.

STB Pin	Operation Mode
L	Normal mode
H	Standby mode

**TIMING CHART**

**(1) Hole signal input**

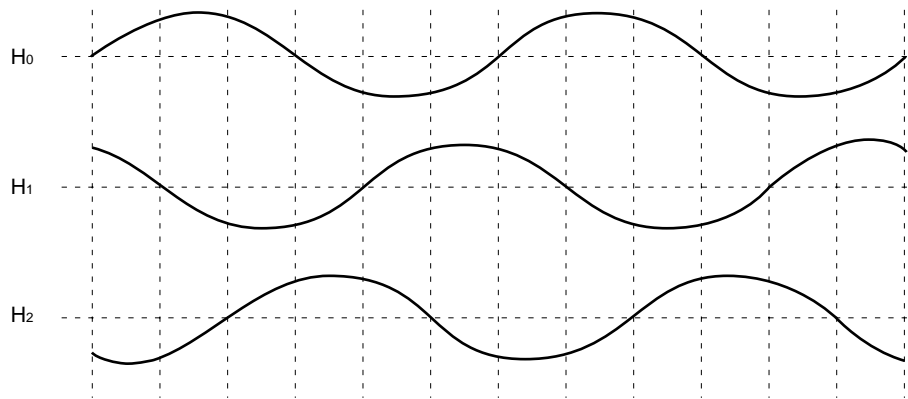

**(2) CMP signal**

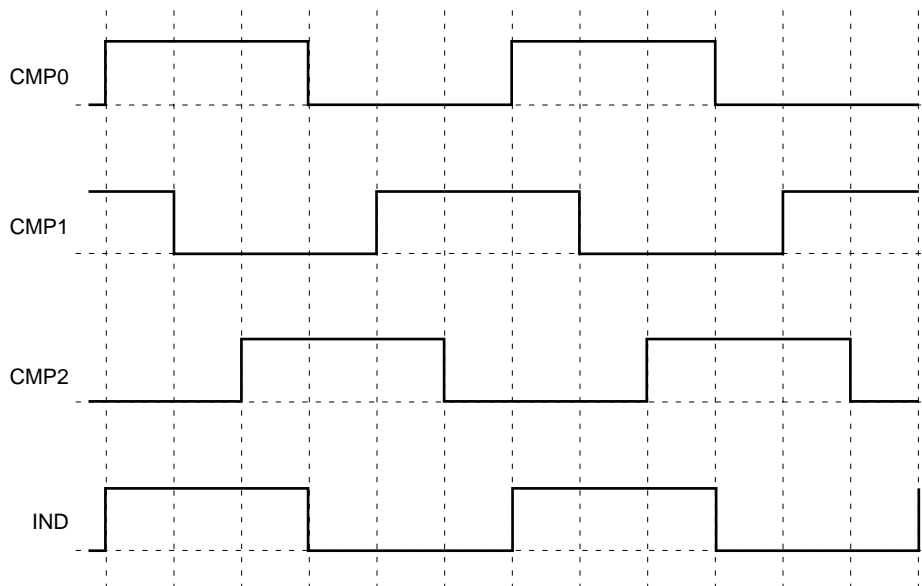



(3) Output MOSFET driving and comparator selection

Q1		SW	SW		ON	ON		SW	SW		ON	ON	
Q2		SW	SW					SW	SW				
Q3	SW		ON	ON		SW	SW		ON	ON		SW	SW
Q4	SW					SW	SW					SW	SW
Q5	ON	ON		SW	SW		ON	ON		SW	SW		ON
Q6				SW	SW					SW	SW		

(4) Motor driving waveform

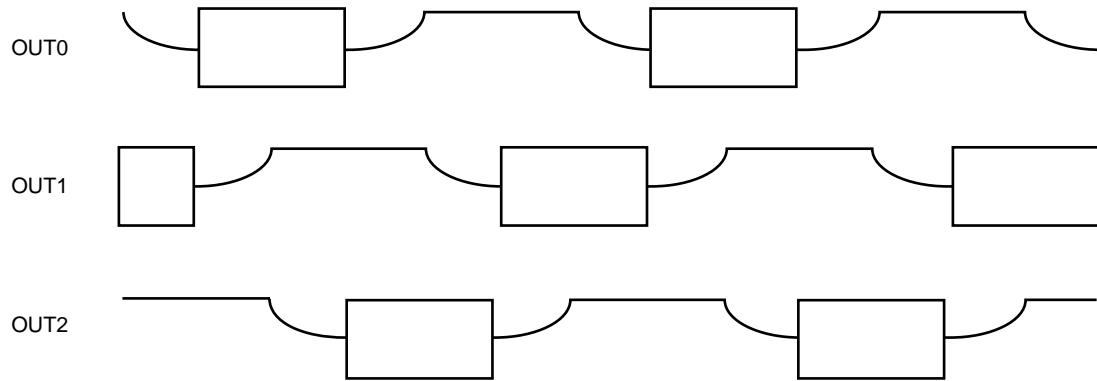

PACKAGE DRAWING

24 PIN PLASTIC SOP (375 mil)

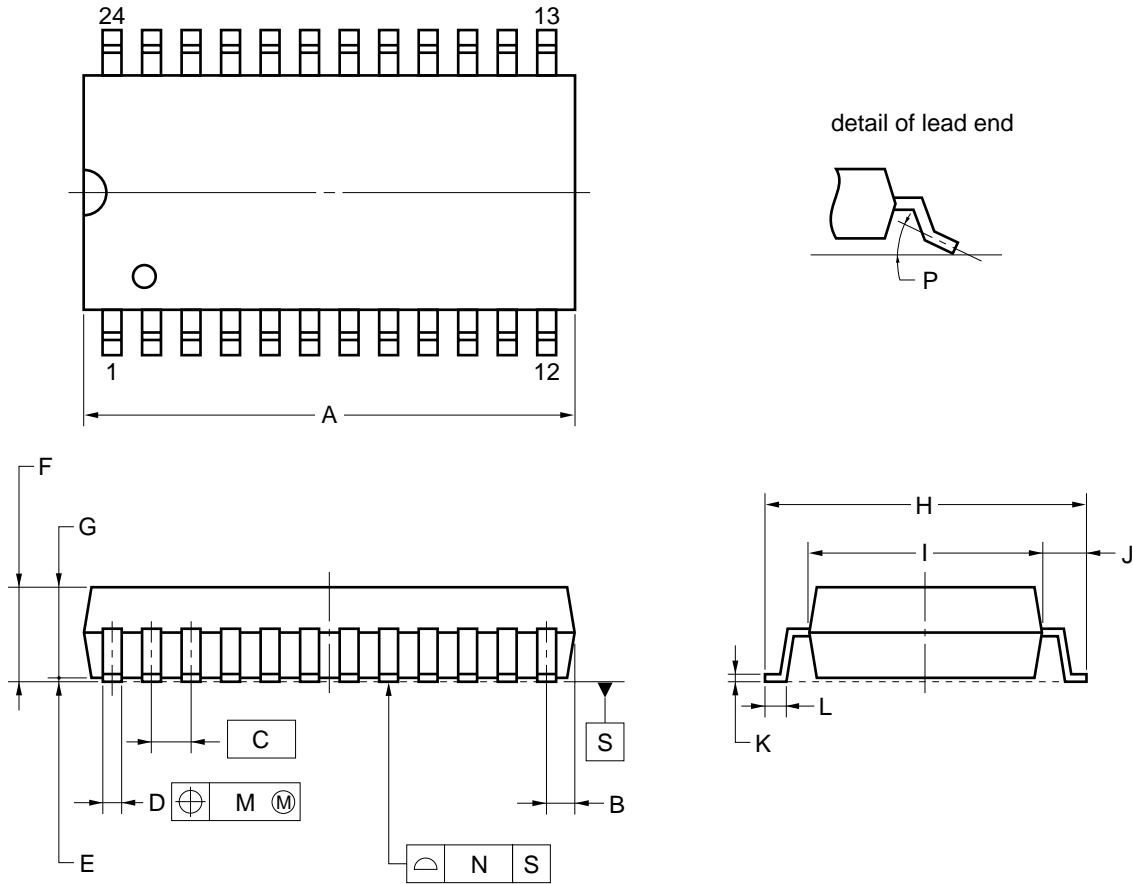

**NOTE**

1. Controlling dimension — millimeter.
2. Each lead centerline is located within 0.12 mm (0.005 inch) of its true position (T.P.) at maximum material condition.

ITEM	MILLIMETERS	INCHES
A	15.3 <sup>+0.41</sup> <sub>-0.2</sub>	0.602 <sup>+0.017</sup> <sub>-0.008</sub>
B	0.87 MAX.	0.035 MAX.
C	1.27 (T.P.)	0.050 (T.P.)
D	0.42 <sup>+0.08</sup> <sub>-0.07</sub>	0.017 <sup>+0.003</sup> <sub>-0.004</sub>
E	0.125±0.075	0.005±0.003
F	2.9 MAX.	0.115 MAX.
G	2.50±0.2	0.098 <sup>+0.009</sup> <sub>-0.008</sub>
H	10.3±0.2	0.406 <sup>+0.008</sup> <sub>-0.009</sub>
I	7.2±0.2	0.283 <sup>+0.009</sup> <sub>-0.008</sub>
J	1.6±0.2	0.063±0.008
K	0.17 <sup>+0.08</sup> <sub>-0.07</sub>	0.007 <sup>+0.003</sup> <sub>-0.004</sub>
L	0.8±0.2	0.031 <sup>+0.009</sup> <sub>-0.008</sub>
M	0.12	0.005
N	0.10	0.004
P	3° <sup>+7°</sup> <sub>-3°</sub>	3° <sup>+7°</sup> <sub>-3°</sub>

P24GT-50-375B-2

**ELECTRICAL SPECIFICATIONS**

Solder this product under the following recommended conditions.

For details of the recommended soldering conditions, refer to information document **Semiconductor Device Mounting Technology Manual (C10535E)**.

For soldering methods and conditions other than those recommended, consult NEC.

Soldering Methods	Soldering Conditions	Recommended Conditions Symbol
Infrared reflow	Package peak temperature: 235 °C, Time: 30 secs. max. (210 °C min.), Number of times: three times max., Number of days: none <sup>Note</sup> , Flux: Rosin-based flux with little chlorine content (chlorine: 0.2 Wt% max.) is recommended.	IR35-00-3
VPS	Package peak temperature: 215 °C, Time: 40 secs. max. (200 °C min.), Number of times: three times max., Number of days: none <sup>Note</sup> , Flux: Rosin-based flux with little chlorine content (chlorine: 0.2 Wt% max.) is recommended.	VP15-00-1
Wave soldering	Package peak temperature: 260 °C, Time: 10 secs. max., Preheating temperature: 120 °C max., Number of times: once, Flux: Rosin-based flux with little chlorine content (chlorine: 0.2 Wt% max.) is recommended.	WS60-00-1

**Note** Number of days in storage after the dry pack has been opened. The storage conditions are at 25 °C, 65% RH MAX.

**Caution** Do not use two or more soldering methods in combination.

No part of this document may be copied or reproduced in any form or by any means without the prior written consent of NEC Corporation. NEC Corporation assumes no responsibility for any errors which may appear in this document.

NEC Corporation does not assume any liability for infringement of patents, copyrights or other intellectual property rights of third parties by or arising from use of a device described herein or any other liability arising from use of such device. No license, either express, implied or otherwise, is granted under any patents, copyrights or other intellectual property rights of NEC Corporation or others.

While NEC Corporation has been making continuous effort to enhance the reliability of its semiconductor devices, the possibility of defects cannot be eliminated entirely. To minimize risks of damage or injury to persons or property arising from a defect in an NEC semiconductor device, customers must incorporate sufficient safety measures in its design, such as redundancy, fire-containment, and anti-failure features.

NEC devices are classified into the following three quality grades:

"Standard", "Special", and "Specific". The Specific quality grade applies only to devices developed based on a customer designated "quality assurance program" for a specific application. The recommended applications of a device depend on its quality grade, as indicated below. Customers must check the quality grade of each device before using it in a particular application.

Standard: Computers, office equipment, communications equipment, test and measurement equipment, audio and visual equipment, home electronic appliances, machine tools, personal electronic equipment and industrial robots

Special: Transportation equipment (automobiles, trains, ships, etc.), traffic control systems, anti-disaster systems, anti-crime systems, safety equipment and medical equipment (not specifically designed for life support)

Specific: Aircrafts, aerospace equipment, submersible repeaters, nuclear reactor control systems, life support systems or medical equipment for life support, etc.

The quality grade of NEC devices is "Standard" unless otherwise specified in NEC's Data Sheets or Data Books. If customers intend to use NEC devices for applications other than those specified for Standard quality grade, they should contact an NEC sales representative in advance.

Anti-radioactive design is not implemented in this product.