

Liquid Crystal Displays

UB-354

features:

TN Transmissive LCD

3.4 inch size

Runs from standard composite video signal

320 x 110 dot display

Single 6 volt power supply

Integrated fluorescent backlight tube

PRODUCT SPECIFICATION	Model No.	Page
	UB-354	1

1. Scope of application

This specification applies to LCD video unit UB-354.

2. Specifications

2-1 Ratings

- (1) Signal mode : In accordance with EIA
- (2) Input impedance : $1\text{M}\Omega$ or more (AC)
- (3) Input signal : Composite video signal 2.0Vp-p (sync. negative polarity)
 - SYNC : 572m Vp-p
 - SETUP : 108m Vp-p
 - LUMINANCE : 1320m Vp-p
- (4) Display element : TN, LCD, transmissive negative display
 - Number of picture elements : 320 dots (H) \times 110 dots (V) (HPS)
 - Picture element form : Rectangle
 - Driving method : 1/55 duty multiplex drive
 - Polarizer : Color phase (NBS)
 - L = 63.2 ± 2.0
 - a = -1.5 ± 2.0
 - b = 2.5 ± 2.0
 - Prior viewing angle : In a direction of 6 o'clock
- (5) Viewing area : 68.0 (H) \times 50.4 (V) mm
- (6) Ambient temperature : Operating range : +5 to +40°C
- (7) Storage temperature : -20 to +60 °C
- (8) Power supply : DC6.0V \pm 10%
- (9) Brightness VR : 50k Ω B type
- (10) Overall size : Refer to overall drawing
- (11) Weight : Approx. 115 g

PRODUCT SPECIFICATION

Model No.

Page

UB-354

2

2-2 Performance

- (1) Measurement conditions Supply voltage : 6.0 V ± 2.5%
 Video signal level : 2.0 Vp-p
 Temperature : 25°C ± 2°C
 Humidity : 65%RH ± 5%RH
- (2) Current consumption Video circuit : Min. 12mA Max. 28mA
 Illumination unit : Min. 250mA Max. 320mA
 (When Brightness volum is 50kΩ)
- (3) Synchronous stability Sync. component : 0.3 Vp-p (In case of entire white 2.0Vp-p)
- (4) Synchronous pull-in range Horizontal : 15.734kHz ± 1kHz
 Vertical : 59.94Hz ± 4Hz
- (5) Gradation Possible to identify white (1) : grey (5) : black (2)
 by 8-gradation grey scale (LEADER-make LCG-400)
- (6) Contrast ratio : CR = 8 or more (Typ., $\phi = 0^\circ$, $\theta = 10^\circ$)
 Maximum value according to actual driving waveform on panel
 single unit

$$CR = \frac{\text{Brightness of white level}}{\text{Brightness of black level}}$$

(7) Viewing angle range

$\theta_1 = 0 \sim 30$ deg. (Typ., $\phi = 0$, $CR > 2$)

$\theta_2 = -40 \sim 40$ deg. (Typ., $\phi = 90$, $CR > 2$)

Best viewing angle (Typ., $\phi = 0$, $\theta = 10$)

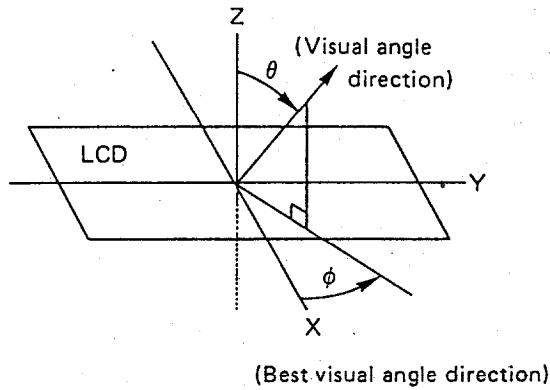

(8) Liquid crystal element life: About 5 years or more

(9) Response time

$T_r =$ or less 100ms (Typ., $\phi = 0$, $\theta = 0$)

$T_d =$ or less 100ms (Typ., $\phi = 0$, $\theta = 0$)

$T_r =$ A time in which transmissivity changes to 90% when applied voltage has been changed from V_{OFF} to V_{ON}

$T_d =$ A time in which transmissivity changes to 10% when applied voltage has been changed from V_{ON} to V_{OFF}

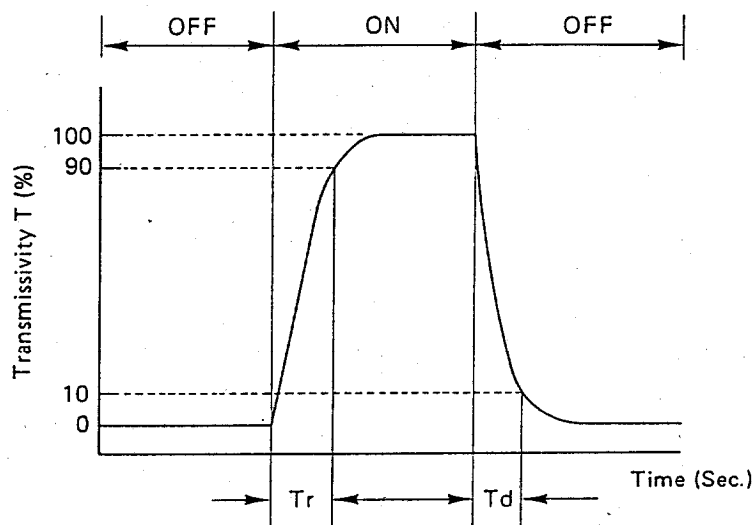

PRODUCT SPECIFICATION

Model No.

Page

UB-354

4

(10) Threshold voltage : $1.7V \pm 0.1V$ (Typ., $\phi = 0, \theta = 0$)

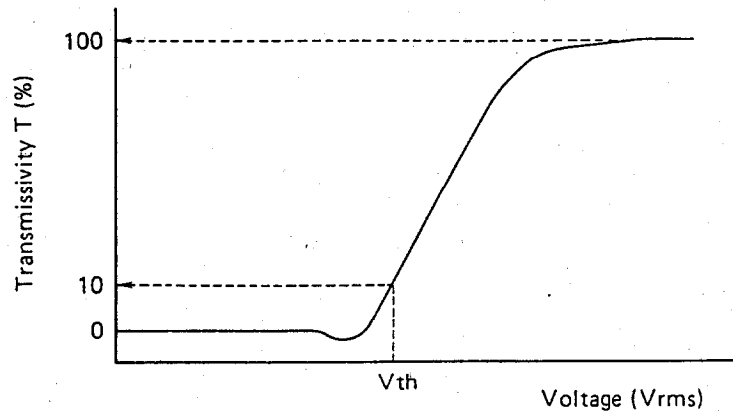

(11) Illumination : Measurement shall be made 5 minutes after lighting.

Average brightness : 2500nit (Standard)

Uneven brightness : -70 ~ +70%

Tube life : Over 1500 hrs to 2000 hrs. (Standard)

When one of more conditions of the following ones have arisen, the tube life shall be regarded as being over :

1) Discharge starting voltage has exceeded 5.0Vdc at 0°C.

2) Uniform light emitting length has reached 80% of specified value (67mm).

3) Brightness has reached 70% of initial value.

Chromaticity : $x = 0.293 \pm 0.03$ $y = 0.333 \pm 0.03$

Measurement of brightness shall be made at the measuring points shown in the drawing below on a diffuser surface.

$Xa = 20mm$ $Xb = 15mm$

$Ya = 15mm$ $Yb = 10mm$

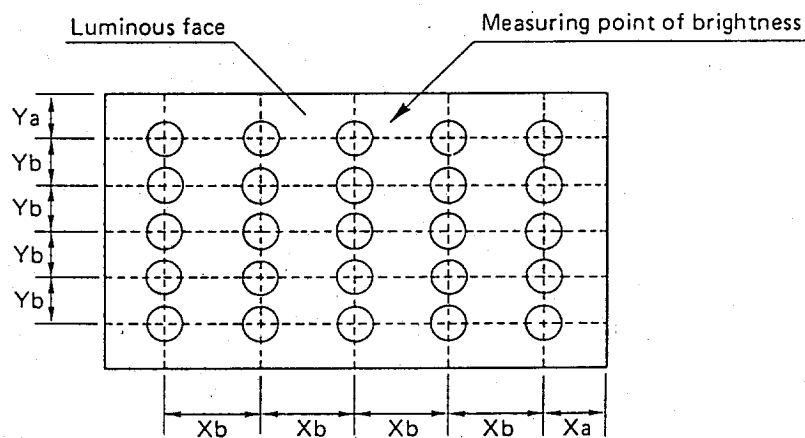

2-3 Block Diagram

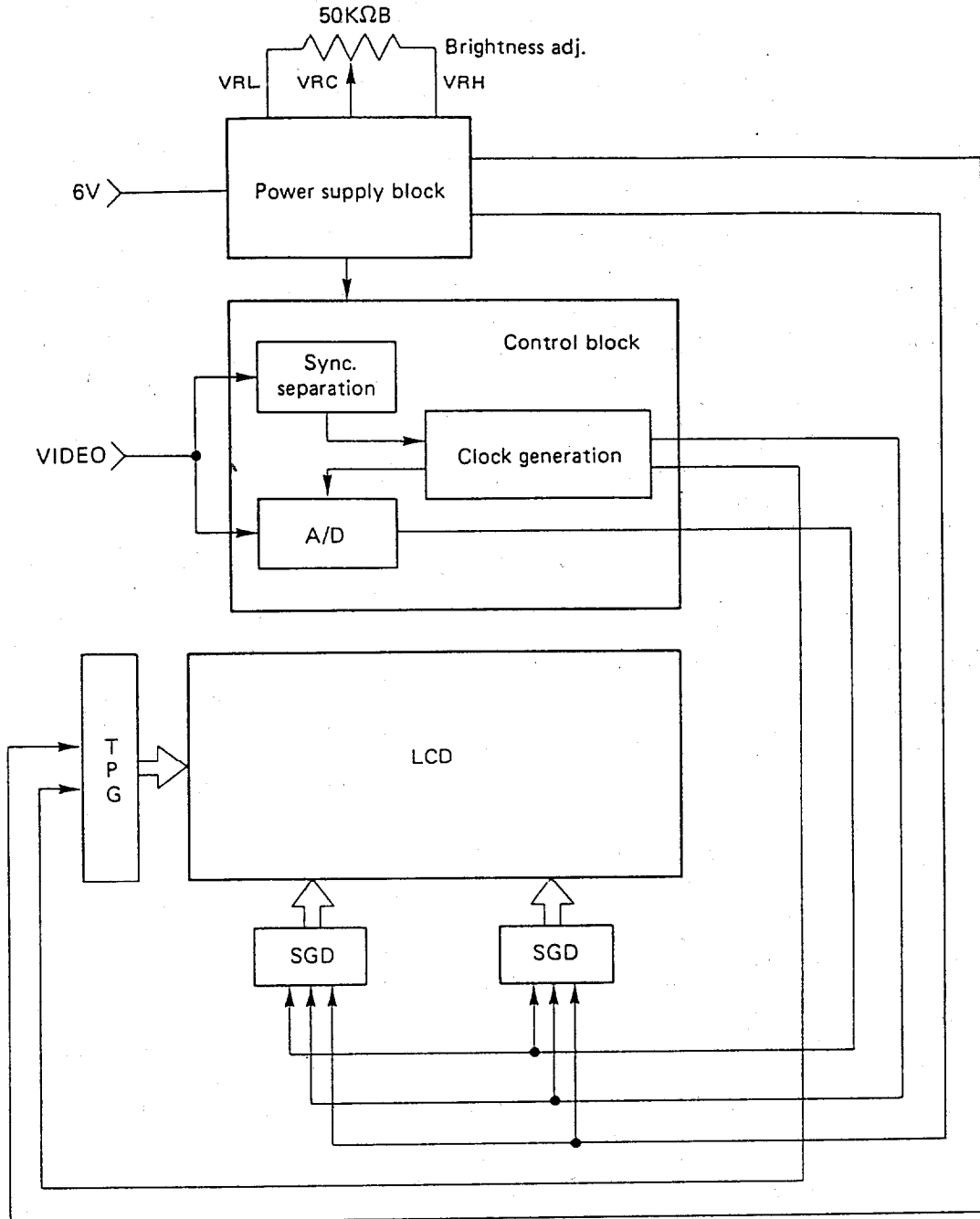

Block diagram of UB-354

PRODUCT SPECIFICATION

Model No.

Page

UB-354

6

2-4 LCD video panel overall drawing

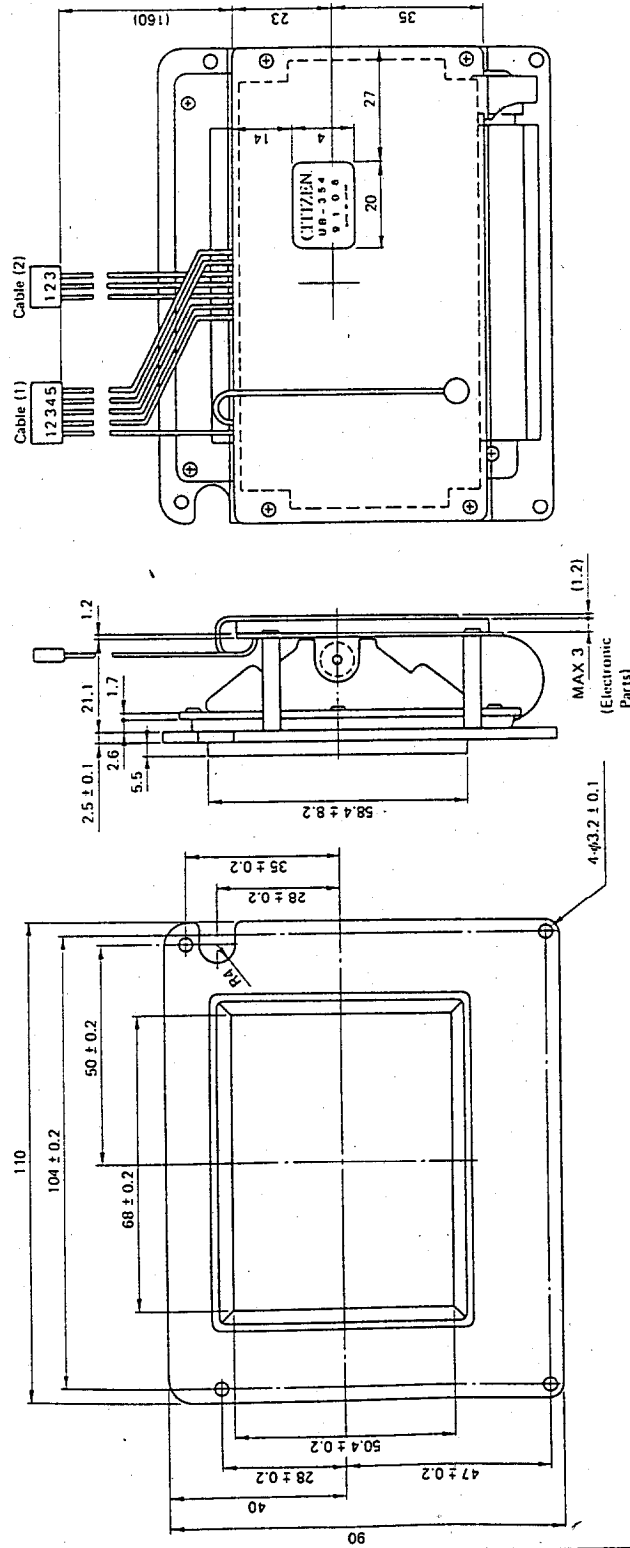

ABLE (1)	PIN NO.	COLOR	SYMBOL	CONNECTOR	TERMINAL
	1	BROWN	6V	JST EH CONNECTOR NO. EHR-5	
	2	RED	6V		
	3	ORANGE	GND		
	4	YELLOW	GND		
	5	GREEN	VIDEO		
ABLE (2)	1	BROWN	VRII	JST EH CONNECTOR NO. EHR-3	
	2	RED	VRC		
	3	ORANGE	VRL		

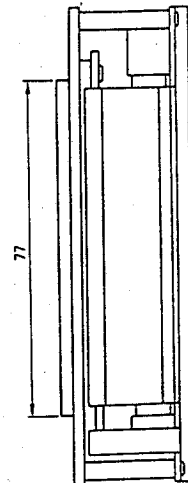

2-5 Package specification

The module shall be put in a conductive polyethylene bag every unit and 20 modules shall be put vertically in one delivery case of which interior has been partitioned with a cushion material shown below.

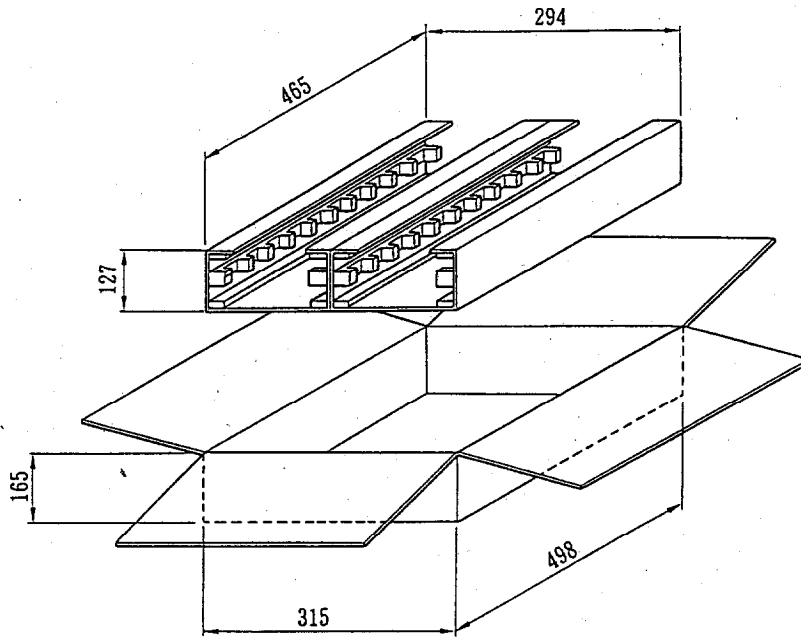

2-6 Lot marking

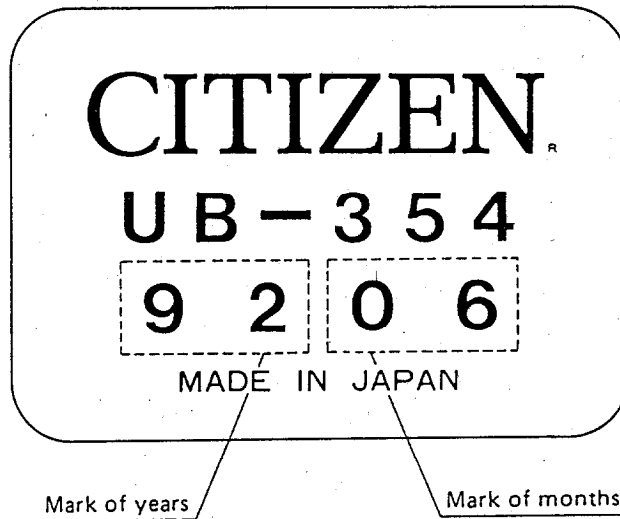

When there is a requirement for special identification on the product, the marking method will be determined by discussion between CITIZEN WATCH Co., Ltd. and the customer.

PRODUCT SPECIFICATION	Model No.	Page
	UB-354	8

3. Cautions

- (1) A polarizer is kept mounted on the surface of LCD panel and before shipping, the polarizer at the surface side is covered with a protective sheet. Before using, take off the protective sheet. A failure to remove the sheet may result in the displayed picture taking an unnecessary color or stripes coming into view.
- (2) Before applying the supply voltage or video signal, make sure the power supply connected to the video unit and the wiring of video signal are right. If the voltage is applied without taking note of the fact that the connection is improper, the unit may break down.
- (3) A semi-fixed resistor on PCB has already been adjusted to enable the most favorable picture to be obtained. Don't touch the semi-fixed resistor anyway. For readjustment, a special measuring instrument is necessary.
- (4) Don't use this LCD video unit in a wet condition with dew ; otherwise the unit may break down.
- (5) Handle the polarizer with the greatest possible care since it is prone to be damage. Do not place a hard, pointed article such as metallic tweezers to the polarizer and do not push or rub the polarizer with any foreign object.
- (6) Be careful not to touch the polarizer with the bare hand. If the polarizer is found dirty, clean it with an absorbent cotton swab or a soft cloth by wiping gently with petroleum benzine. Do not use such chemicals as acetone, ethanol, toluene, isopropyl alcohol and so on for cleaning ; otherwise, a reaction phenomenon occurs and deterioration may result.
- (7) Also, if saliva or water droplets are left on the surface of the polarizer for a long time, it may become deformed or discolored. So, remove them right away.
- (8) If the LCD panel has been broken and the liquid crystal substance has leaked out, avoid inhaling or touching it. If the liquid crystal substance has contacted the skin or clothes, wash it away quickly.
- (9) The circuit substrate includes ICs which are very easily damaged by static electricity. So, handle the substrate with utmost care.
- (10) Mount being careful not to put undue bend or twist on the unit ; otherwise, LCD panel breaks or the circuit trouble as the case may be.
- (11) To protect LCD panel, especially the polarizer surface, put a transparent protective board (for example, acrylic board or glass board) on the product case.
- (12) Avoid keeping the unit in a humid place with high temperature.
- (13) Do not expose the unit to direct sunlight.
- (14) Take the proper steps to prevent any unnecessary pressure on the unit.