

AZ576

20 AMP MINIATURE POWER RELAY

FEATURES

- 20 Amp switching capability
- Available in SPST-NO and SPDT versions
- Dielectric strength of 5000 VAC
- Ambient temperature up to 105°C (221°F)
- Epoxy sealed versions available
- Compact size, low seated height of 15.3 mm
- UL / CUR file E44211
- TÜV: R50400691

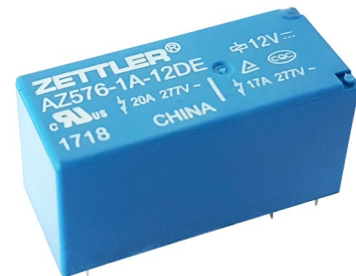

CONTACTS

Arrangement	SPST-NO (1 Form A) SPDT (1 Form C)
Ratings (max.) switched power switched current switched voltage	(resistive load) 510 W or 5540 VA 20 A 30 VDC* or 277 VAC * Note: If switching voltage is greater than 30 VDC, special precautions must be taken. Please contact the factory.
Rated Loads UL/CUR Normally Open (NO)	20 A at 277 VAC, resistive, 85°C, 30k cycles 20 A at 120 VAC, resistive, 65°C, 100k cycles 17 A at 277 VAC, resistive, 105°C, 100k cycles 16 A at 277 VAC, general use, 85°C, 100k cycles 16 A at 277 VAC, resistive, 105°C, 100k cycles 17 A at 30 VDC, resistive, 105°C, 100k cycles 5 A at 120/277 VAC, pilot duty, 85°C, 30k cycles 1 HP at 120/240/480 VAC, 100k cycles 1.5 HP at 120 VAC, 85°C, 100k cycles 10 FLA / 60 LRA at 250 VAC, 100k cycles TV-8 at 120 VAC, 25k cycles TV-5 at 120 VAC, 85°C, 25k cycles 5 A at 120 VAC, Ballast, 85°C, 25k cycles 8 A at 120 VAC, Tungsten, 85°C, 30k cycles
Normally Closed (NC)	20 A at 277 VAC, resistive, 85°C, 30k cycles 17 A at 277 VAC, resistive, 105°C, 30k cycles 16 A at 277 VAC, general use, 85°C, 30k cycles 17 A at 30 VDC, resistive, 105°C, 30k cycles 5 A at 120/277 VAC, pilot duty, 85°C, 30k cycles 1 HP at 120/240/480 VAC, 100k cycles 10 FLA / 60 LRA at 250 VAC, 100k cycles
TÜV	17 A at 277 VAC, resistive, 105°C, 100k cycles * 17 A at 30 VDC, resistive, 105°C, 100k cycles * * Note: Versions with 15 VDC coil voltage are not TÜV approved.
Contact material	AgSnO ₂ (silver tin oxide)
Initial resistance max. typ.	100 mΩ (1A / 6VDC, voltage drop method) < 10 mΩ (at rated current)

COIL

Nominal coil voltages	see coil voltage specifications tables
Dropout	≥ 5% of nominal coil voltage
Coil power nominal at pickup voltage	typ. at 23°C (73°F) coil temperature 400 mW 225 mW
Temperature Rise	42 K (76°F) typ. at nominal coil voltage
Max. temperature	155°C (311°F), class F insulation system

GENERAL DATA

Life Expectancy mechanical electrical	(minimum operations) 1 x 10 ⁷ see UL/CUR/TÜV rated loads
Operate Time max.	(at nominal coil voltage) 15 ms
Release Time max.	(at nom. coil voltage, without coil suppression) 8 ms
Dielectric Strength coil to contacts between open contacts	(at sea level for 1 min.) 5000 VAC 1000 VAC
Surge voltage coil to contacts	(1.2/50 μs) 10 kV
Insulation Resistance	1000 MΩ (min.) at 23°C, 500 VDC, 50% RH
Insulation coil to contacts	Reinforced insulation
Temperature Range operating	(at nominal coil voltage) -40°C (-40°F) to 105°C (221°F)
Vibration resistance	0.062" (1.5 mm) DA at 10-55 Hz
Shock resistance	10 g
Enclosure protection category material group flammability	P.B.T. polyester RT II - flux proof, RT III - wash tight Illa UL94 V-0
Terminals	Tinned copper alloy, P. C.
Soldering max. temperature max. time	270 °C (518°F) 5 seconds
Cleaning max. solvent temp. max. immersion time	(RT III - wash tight versions only) 80°C (176°F) 30 seconds
Dimensions length width height	29.3 mm (1.154") 12.7 mm (0.500") 15.3 mm (0.602")
Weight	14 grams (approx.)
Packing unit in pcs	20 per plastic tube / 1000 per carton box
Compliance	UL 508, IEC 61810-1, RoHS, REACH

ZETTLER

AZ576

COIL VOLTAGE SPECIFICATIONS

Nominal Coil VDC	Must Operate VDC	Max. Coil VDC	Nom. Current mA (ref.)	Resistance Ohm ($\pm 10\%$)
5	3.75	7.5	80.0	62
6	4.5	9.0	66.7	90
9	6.75	13.5	44.4	202
12	9.0	18.0	33.3	360
15	11.25	22.5	26.8	560
18	13.5	27.0	22.2	810
22	16.5	33.0	18.2	1210
24	18.0	36.0	16.7	1440
36	27.0	54.0	11.1	3240
48	36.0	72.0	8.3	5760
60	45.0	90.0	6.7	9000
110	82.5	165.0	3.6	30250

Note: All values at 23°C (73°F), upright position, terminals downward.

ORDERING DATA

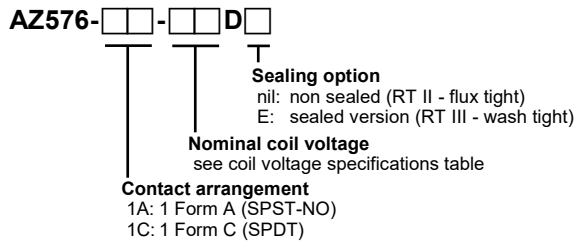

Example ordering data

AZ576-1A-9D 1 Form A, 9 VDC nom. coil voltage, RT II flux tight
 AZ576-1C-12DE 1 Form C, 12 VDC nom. coil voltage, RT III wash tight

MECHANICAL DATA

Dimensions in mm. If not stated otherwise, tolerance: ± 0.3 mm

Notes: * Pin dimensions for reference only and given without tin coating.
 ** Only for 1 Form C (SPDT) contact arrangement versions.

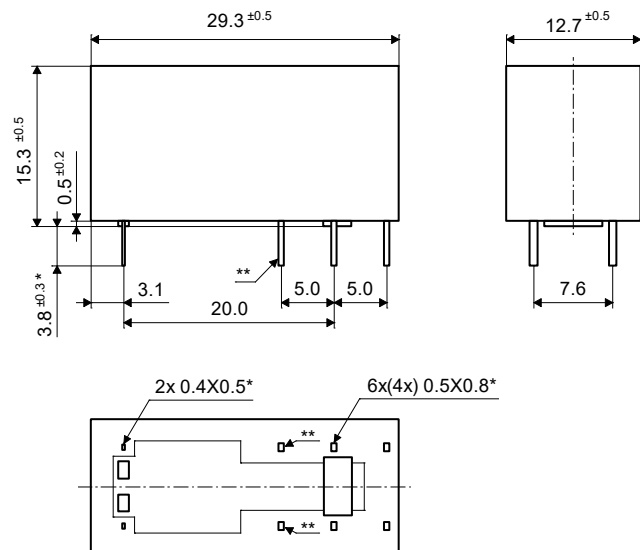

PC BOARD LAYOUT

Layout recommendation. Dimensions in mm. Viewed towards terminals.

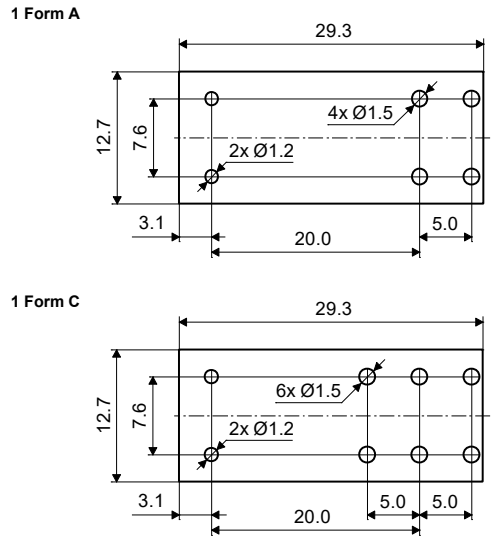

WIRING DIAGRAMS

Viewed towards terminals.

Note: Connect associated load terminals on PCB to ensure proper operation and service life.

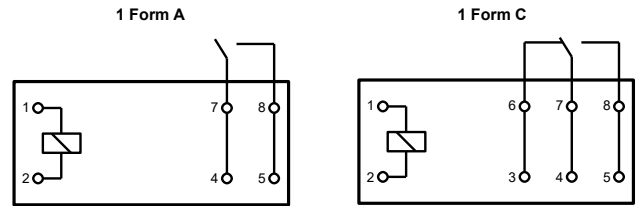

NOTES

1. All values at reference temperature of 23°C (73°F) unless stated otherwise.
2. Relay may pull in with less than "Must Operate" value.
3. "Maximum Coil Voltage" is the maximum voltage the coil can endure for a short period of time.
4. Coil suppression circuits such as diodes, etc. in parallel to the coil will lengthen the release time.
5. Relay adjustment may be affected if excessive shock is applied to the relay or if undue pressure is exerted on the relay case.
6. Substances containing silicone or phosphorus must be avoided in the vicinity to the relay as these will shorten its service life.
7. RTII (flux proof) relays must not be washed, immersion cleaned or conformal coated.
8. Specifications subject to change without notice.

AZ576

DISCLAIMER

This product specification is to be used in conjunction with the application notes which can be downloaded from the regional ZETTLER relay websites. The specification provides an overview of the most significant part features. Any individual applications and operating conditions are not taken into consideration. It is recommended to test the product under application conditions. Responsibility for the application remains with the customer. Proper operation and service life cannot be guaranteed if the part is operated outside the specified limits.

ZETTLER GROUP

Building on a foundation of more than a century of expertise in German precision engineering, ZETTLER Group is a world-class enterprise, engaged in the design, manufacturing, sales and distribution of electronic components. Our industry leadership is based on a unique combination of engineering competence and global scale.

For more information on other ZETTLER Group companies, please visit [ZETTLER-group.com](https://www.zettler-group.com). For support on this product or other ZETTLER relays, please visit one of the group sites below.

SITES FOR ZETTLER RELAYS

NORTH AMERICA

American Zettler, Inc.
www.azettler.com
sales@azettler.com

EUROPE

Zettler Electronics, GmbH
www.zettlerelectronics.com
office@zettlerelectronics.com

Zettler Electronics, Poland
www.zettlerelectronics.pl
office@zettlerelectronics.pl

CHINA

Zettler Group, China
www.zettlercn.com
relay@zettlercn.com

ASIA PACIFIC

Zettler Electronics (HK) Ltd.
www.zettlerhk.com
sales@zettlerhk.com



ZETTLER