

FEATURES

- Output voltage: 3.3V, 5.0V, 12V, and adjustable output version
- Adjustable version output voltage range: 1.23V to 37V±4%
- 52KHz±15% fixed switching frequency
- Voltage mode non-synchronous PWM control
- Thermal-shutdown and current-limit protection
- ON/OFF shutdown control input
- Operating voltage can be up to 40V
- Output load current: 3A
- Low power standby mode
- Built-in switching transistor on chip
- TO220-5L, TO263-5L packages

APPLICATIONS

- Simple High-efficiency step-down regulator
- On-card switching regulators
- Positive to negative converter

PIN CONFIGURATION

(1) TO220-5L

(Top View)

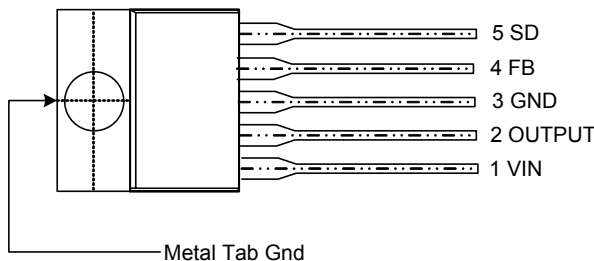

(2) TO263-5L

(Top View)

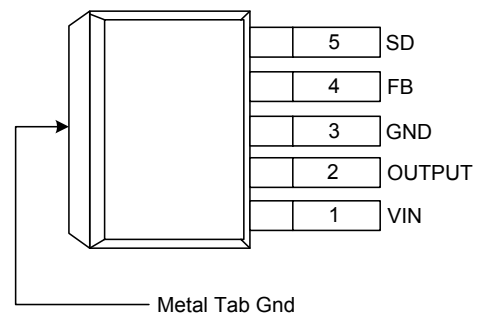

Symbol	Name	Descriptions
1	Vin	Operating Voltage Input
2	Output	Switching Output
3	Gnd	Ground
4	FB	Output Voltage Feedback Control
5	SD	ON/OFF Shutdown

GENERAL DESCRIPTION

The VVP3120 series are monolithic IC that design for a step-down DC/DC converter, and own the ability of driving a 3A load without additional transistor component. Due to reducing the number of external component, the board space can be saved easily. The external shutdown function can be controlled by logic level and then come into standby mode. The internal compensation makes feedback control have good line and load regulation without external design. Regarding protected function, thermal shutdown is to prevent over temperature operating from damage, and current limit is against over current operating of the output switch. The VVP3120 series operates at a switching frequency of 52 KHz thus allowing smaller sized filter components than what would be needed with lower frequency switching regulators. Other features include a guaranteed ±4% tolerance on output voltage under specified input voltage and output load conditions, and ±15% on the oscillator frequency. The output version included fixed 3.3V, 5V, 12V, and an adjustable type. The packages are available in a standard 5-lead TO-220 package , 5-lead TO-263 package.

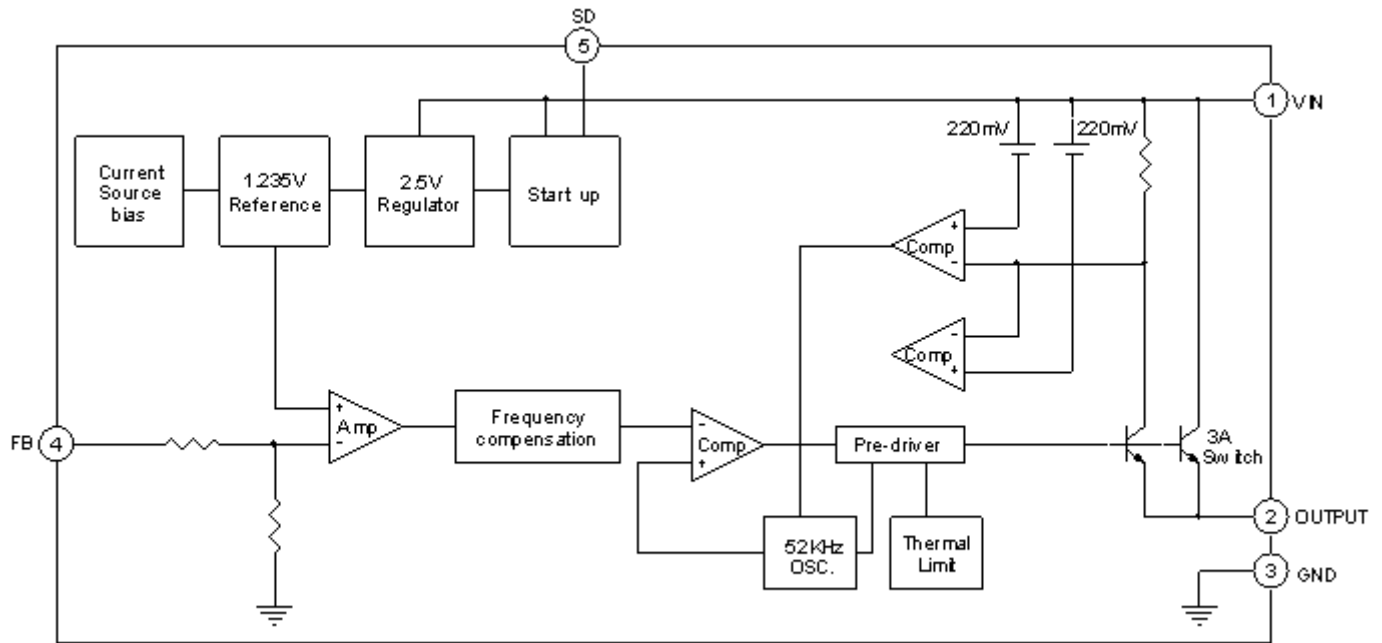
■ BLOCK DIAGRAM

■ ABSOLUTE MAXIMUM RATINGS

Symbol	Paramrter	Rating	Unit
V _{CC}	Supply Voltage	+45	V
V _{SD}	ON/OFF Pin input Voltage	-0.3 to +25	V
V _{FB}	Feedback Pin Voltage	-0.3 to +25	V
V _{OUT}	Output Voltage to Ground	-1	V
P _D	Power Dissipation	Internally Limited	W
T _{ST}	Storage Temperature	-65 to +150	
T _{OP}	Operating Temperature	-40 to +125	
V _{OP}	Operating Voltage	+4.5 to +40	V

■ ELECTRICAL CHARACTERISTICS (ALL OUTPUT VOLTAGE VERSIONS)

 Unless otherwise specified, $V_{IN}=12V$ for 3.3V,5V, adjustable version and $V_{IN}=24V$ for the 12V version. $I_{LOAD}=0.5A$

Symbol	Paramrter	Conditions	Min.	Typ.	Max.	Unit
I_B	Feedback bias current	$V_{FB}=1.3V$ (Adjustable version only)		40	50 100	nA
F_{OSC}	Oscillator frequency		44 38	52	60 66	KHz
V_{SAT}	Saturation voltage	$I_{OUT}=3A$ no outside circuit $V_{FB}=0V$ force driver on		1.16	1.4	V
DC	Max.Duty Cycle(ON)	$V_{FB}=0V$ force driver on			100	%
	Min.Duty Cycle(OFF)	$V_{FB}=12V$ force driver off	0			
I_{CL}	Current limit	Peak current no outside circuit $V_{FB}=0V$ force driver on	3.6		6.9	A
I_L	Output=0	Output leakage current no outside circuit $V_{FB}=12V$ force driver off $V_{IN}=40V$			50	μA
	Output=-1			5	30	mA
I_Q	Quiescent Current	$V_{FB}=12V$ force driver off		7.8	10	mA
I_{STBY}	Standby Quiesient Current	ON/OFF Pin=5V $V_{IN}=40V$		85	200	μA
V_{IL}	ON/OFF pin logic input threshold voltage	Low(regultaor ON)		1.4	0.6	V
V_{IH}		High(regultaor OFF)	2.0			
I_H	ON/OFF pin logic input current	$V_{LOGIC}=2.5V$ (OFF)		6	15	μA
I_L	ON/OFF pin input current	$V_{LOGIC}=0.5V$ (ON)		0.02	5	
θ_{JC}	Thermal Resistance	TO220-5L	Junction to case		2.5	$^{\circ}W$
		TO263-5L		3.5		
θ_{JA}	Thermal Resistance With copper area of approximately 3 in ²	TO220-5L	Junction to ambient		28	$^{\circ}W$
		TO263-5L		30		

■ ELECTRICAL CHARACTERISTICS (CONTINUED)

	Symbol	Parameter	Conditions	Typ.	Limit	Unit
VVP3120-ADJ	V_{FB}	Output Feedback	$4.5V \leq V_{IN} \leq 40V$ $0.2A \leq I_{LOAD} \leq 3A$ V_{OUT} programmed for 3V	1.23	1.193/ 1.18 1.267/ 1.28	V V_{MIN} V_{MAX}
	η	Efficiency	$V_{IN} = 12V, I_{LOAD} = 3A$	72		%
VVP3120-3.3V	V_{OUT}	Output voltage	$5V \leq V_{IN} \leq 40V$ $0.2A \leq I_{LOAD} \leq 3A$	3.3	3.168/ 3.135 3.432/ 3.465	V V_{MIN} V_{MAX}
	η	Efficiency	$V_{IN} = 12V, I_{LOAD} = 3A$	72		%
VVP3120-5V	V_{OUT}	Output voltage	$7V \leq V_{IN} \leq 40V$ $0.2A \leq I_{LOAD} \leq 3A$	5	4.8/ 4.75 5.2/ 5.25	V V_{MIN} V_{MAX}
	η	Efficiency	$V_{IN} = 12V, I_{LOAD} = 3A$	79		%
VVP3120-12V	V_{OUT}	Output voltage	$15V \leq V_{IN} \leq 40V$ $0.2A \leq I_{LOAD} \leq 3A$	12	11.52/ 11.4 12.48/ 12.6	V V_{MIN} V_{MAX}
	η	Efficiency	$V_{IN} = 15V, I_{LOAD} = 3A$	90		%

 Specifications with **boldface type** are for full operating temperature range, the other type are for $T_J=25^{\circ}C$.

■ TYPICAL PERFORMANCE CHARACTERISTICS

Normalized Output Voltage

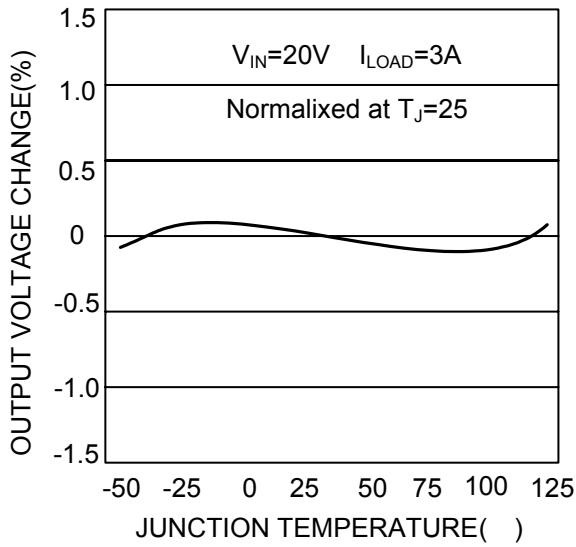

Switch Saturation Voltage

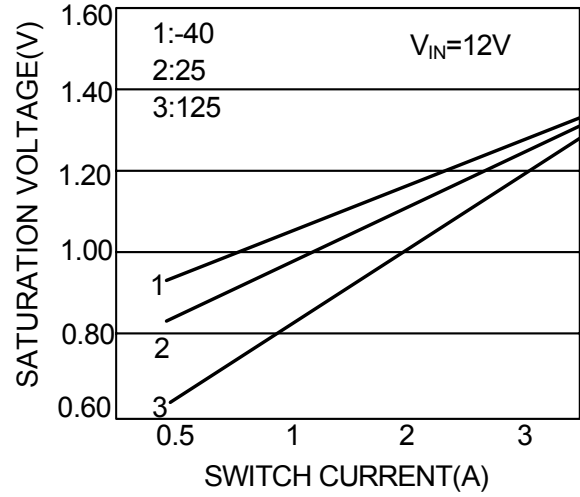

Dropout Voltage

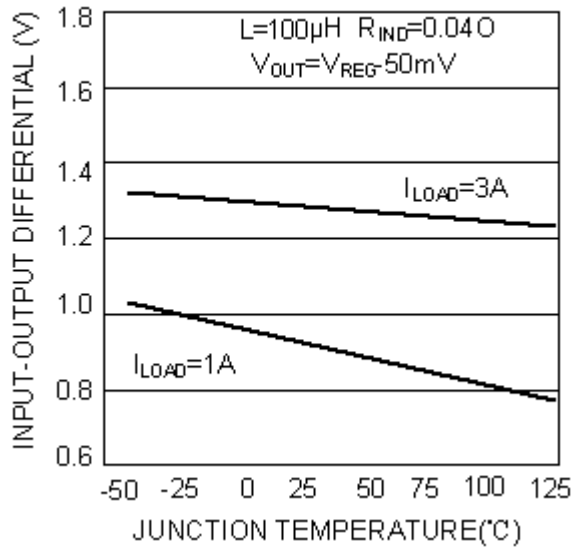

Switching Frequency

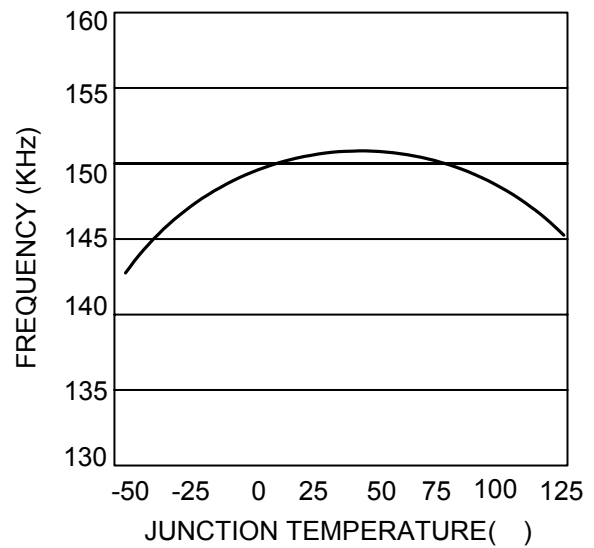

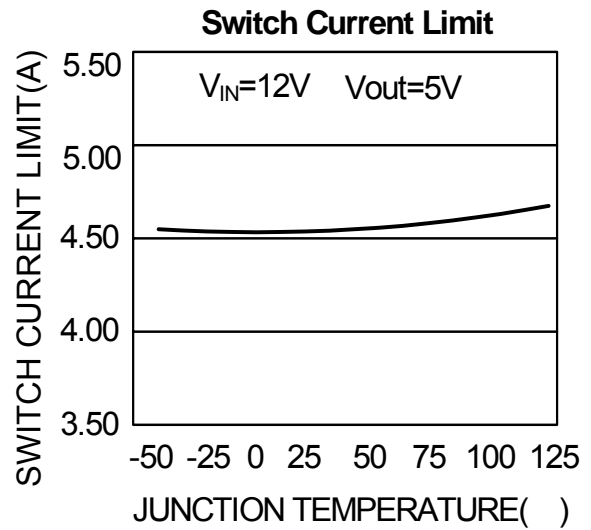
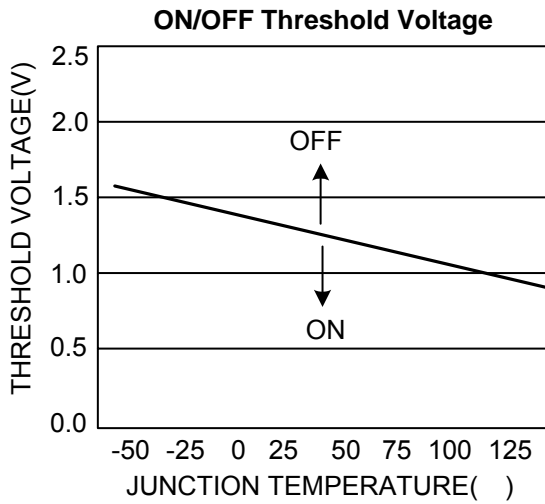

■ **TYPICAL APPLICATION CIRCUITS**

(1) Fixed Output Circuit

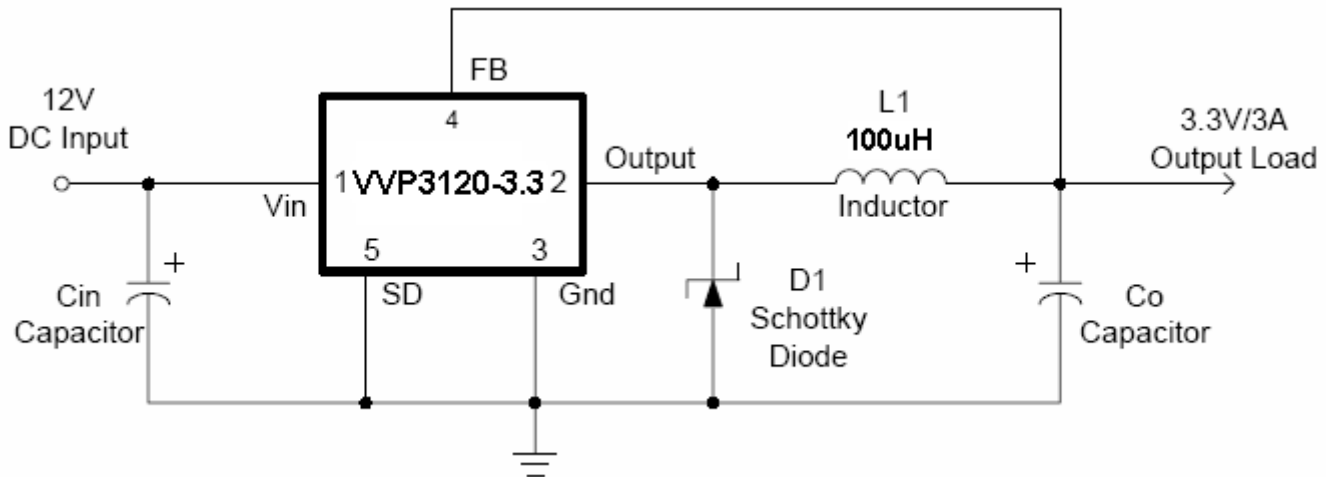

(2) Adjustable Output Circuit

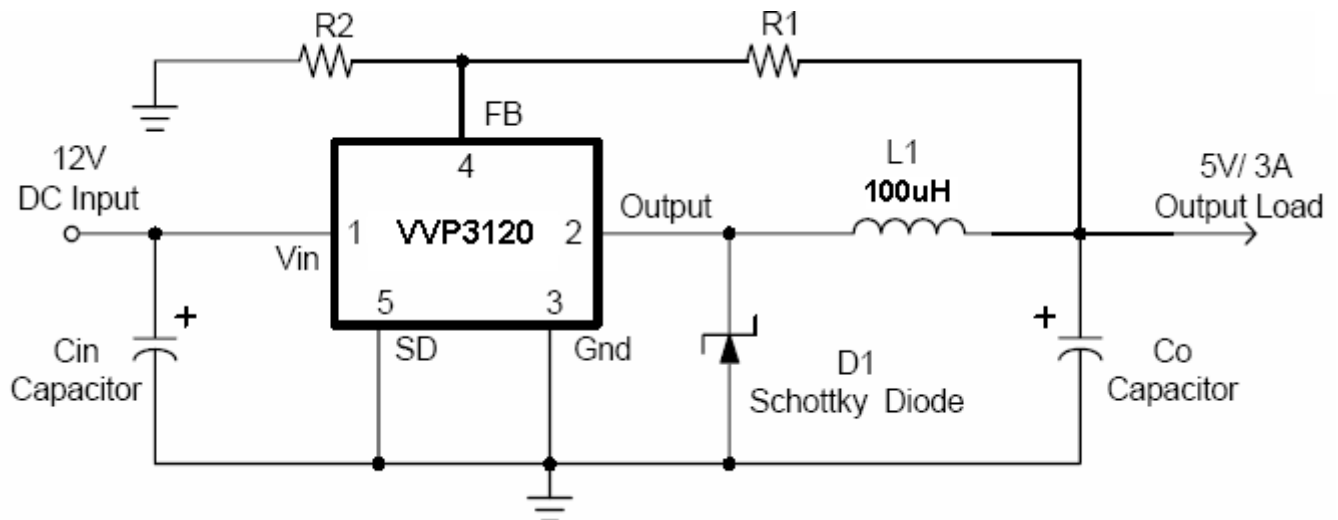

■ FUNCTION DESCRIPTION

Pin Function

V_{IN}
This is the positive input supply for the IC switching regulator. A suitable input bypass capacitor must be present at this pin to minimize voltage transients and to supply the switching currents needed by the regulator.

Ground

Circuit ground.

Output

Internal switch. The voltage at this pin switches between $(V_{IN} - V_{SAT})$ and approximately $-0.5V$, with a duty cycle of approximately V_{OUT} / V_{IN} . To minimize coupling to sensitive circuitry, the PC board copper area connected to this pin should be kept a minimum.

Feedback

Senses the regulated output voltage to complete the feedback loop.

ON/OFF

Allows the switching regulator circuit to be shutdown using logic level signals thus dropping the total input supply current to approximately 150uA. Pulling this pin below a threshold voltage of approximately 1.3V turns the regulator on, and pulling this pin above 1.3V (up to a maximum of 25V) shuts the regulator down. If this shutdown feature is not needed, the ON/OFF pin can be wired to the ground pin or it can be left open, in either case the regulator will be in the ON condition.

Thermal Considerations

The VVP3120 is available in three packages, a 5-pin TO-220, a 5-pin surface mount TO-263.

The TO-220 package needs a heat sink under most conditions. The size of the heat sink depends on the input voltage, the output voltage, the load current and the ambient temperature. The VVP3120 junction temperature rises above ambient temperature for a 3A load and different input and output voltages. The data for these curves was taken with the VVP3120 (TO-220 package) operating as a buck switching regulator in an ambient temperature of 25°C (still air). These temperature rise numbers are all approximate and there are many factors that can affect these temperatures. Higher ambient temperatures require more heat sinking.

The TO-263 surface mount package tab is designed to be soldered to the copper on a printed circuit board. The copper and the board are the heat sink for this package and the other heat producing components, such as the catch diode and inductor. The PC board copper area that the package is soldered to should be at least 0.4 in², and ideally should have 2 or more square inches of 2 oz. Additional copper area improves the thermal characteristics, but with copper areas greater than approximately 6 in², only small improvements in heat dissipation are realized. If further thermal improvements are needed, double sided, multilayer PC board with large copper areas and/or airflow are recommended.

The VVP3120 (TO-263 package) junction temperature rise above ambient temperature with a 2A load for various input and output voltages. This data was taken with the circuit operating as a buck switching regulator with all components mounted on a PC board to simulate the junction temperature under actual operating conditions. This curve can be used for a quick check for the approximate junction temperature for various conditions, but be aware that there are many factors that can affect the junction temperature. When load currents higher than 2A are used, double sided or multilayer PC boards with large copper areas and/or airflow might be needed, especially for high ambient temperatures and high output voltages.

For the best thermal performance, wide copper traces and generous amounts of printed circuit board copper should be used in the board layout. (Once exception to this is the output (switch) pin, which should not have large areas of copper.) Large areas of copper provide the best transfer of heat (lower thermal resistance) to the surrounding air, and moving air lowers the thermal resistance even further.

Package thermal resistance and junction temperature rise numbers are all approximate, and there are many factors that will affect these numbers. Some of these factors include board size, shape, thickness, position, location, and even board temperature. Other factors are, trace width, total printed circuit copper area, copper thickness, single or double-sided, multilayer board and the amount of solder on the board. The effectiveness of the PC board to dissipate heat also depends on the size, quantity and spacing of other components on the board, as well as whether the surrounding air is still or moving. Furthermore, some of these components such as the catch diode will add heat to the PC board and the heat can vary as the input voltage changes. For the inductor, depending on the physical size, type of core material and the DC resistance, it could either act as a heat sink taking heat away from the board, or it could add heat to the board.

■ ORDERING INFORMATION

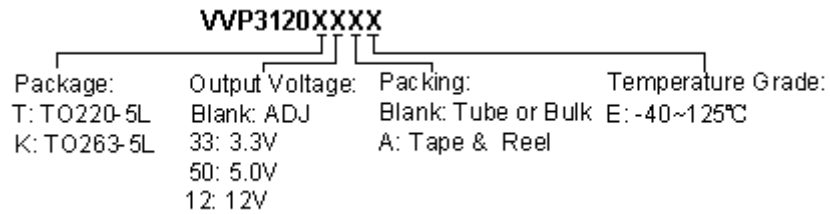

■ MARKING INFORMATION

1) TO220-5L

2) TO263-5L

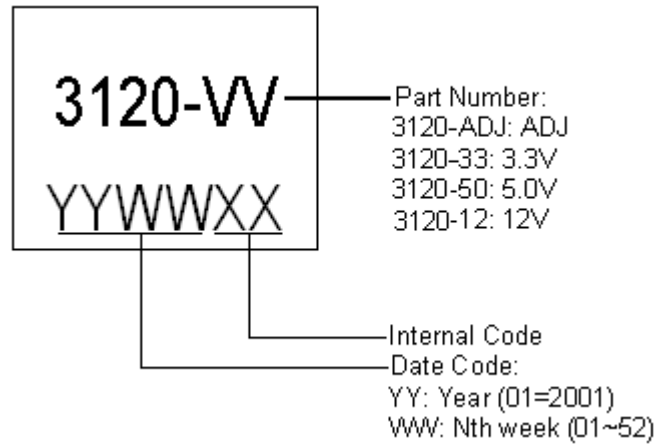
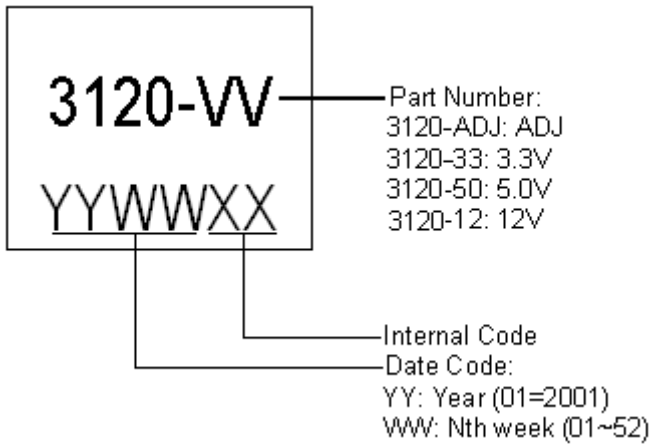

■ PACKAGE INFORMATION

1) TO220-5L

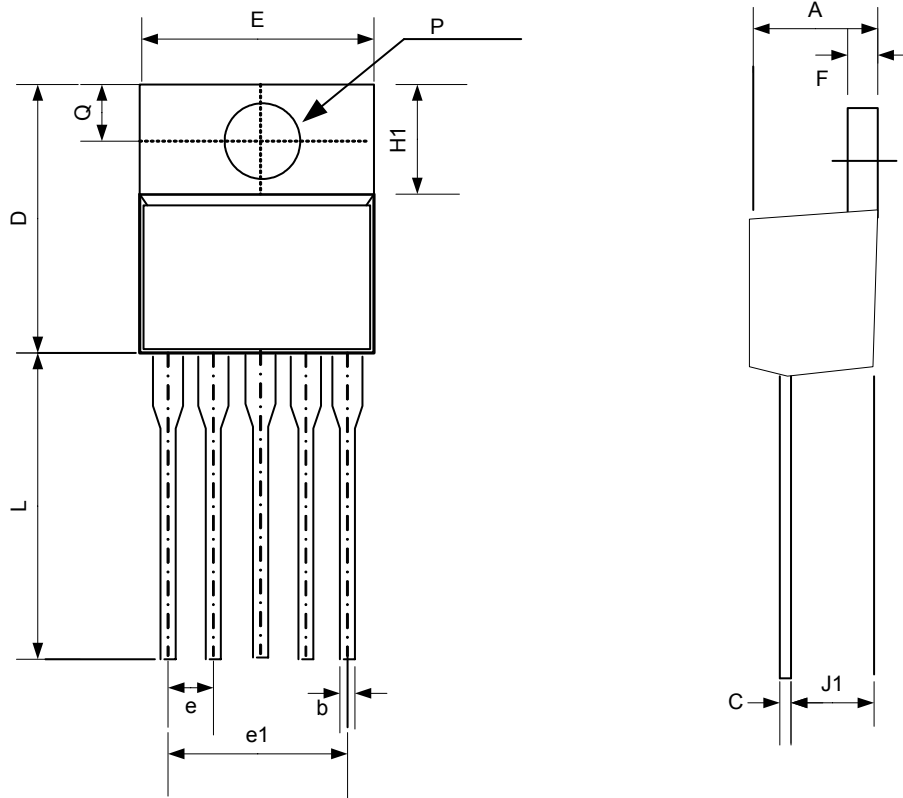

Symbol	Dimensions In Millimeters			Dimensions In Inches		
	Min.	Nom.	Max.	Min.	Nom.	Max.
A	4.07	4.45	4.82	0.160	0.175	0.190
b	0.76	0.89	1.02	0.030	0.035	0.040
C	0.36	0.50	0.64	0.014	0.020	0.025
D	14.22	14.86	15.50	0.560	0.585	0.610
E	9.78	10.16	10.54	0.385	0.400	0.415
e	1.57	1.71	1.85	0.062	0.067	0.073
e1	6.68	6.81	6.93	0.263	0.268	0.273
F	1.14	1.27	1.40	0.045	0.050	0.055
H1	5.46	6.16	6.86	0.215	0.243	0.270
J1	2.29	2.74	3.18	0.090	0.108	0.125
L	13.21	13.97	14.73	0.520	0.550	0.580
P	3.68	3.81	3.94	0.145	0.150	0.155
Q	2.54	2.73	2.92	0.100	0.107	0.115

2) TO263-5L

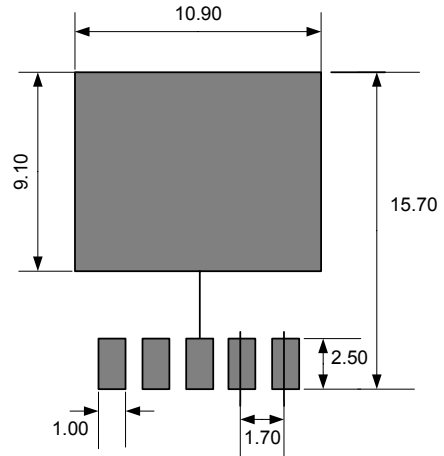
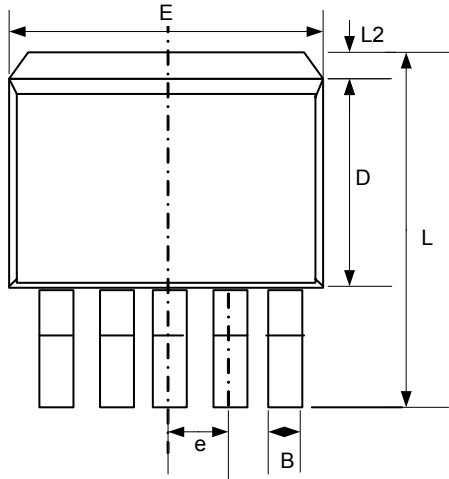

Land Pattern Recommendation (Unit: mm)

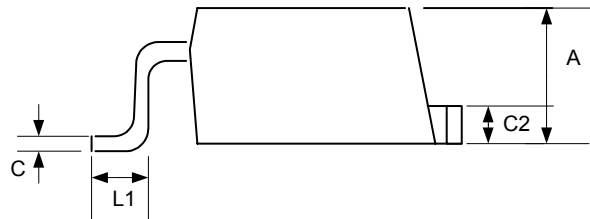
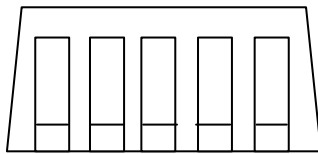

Symbol	Dimensions In Millimeters			Dimensions In Inches		
	Min.	Nom.	Max.	Min.	Nom.	Max.
A	4.07	4.46	4.85	0.163	0.176	0.194
B	0.51	0.84	1.02	0.020	0.033	0.041
C	0.36	0.50	0.74	0.014	0.020	0.030
C2	1.14	1.27	1.65	0.046	0.050	0.066
D	8.20	9.15	9.65	0.328	0.360	0.380
E	9.65	10.16	10.67	0.386	0.400	0.427
e	1.57	1.71	1.85	0.063	0.068	0.074
L	14.45	15.24	15.88	0.578	0.600	0.635
L1	1.78	2.54	2.79	0.071	0.100	0.110
L2			2.92			0.115