

700mA Synchronous PWM/PSM Step-Down DC/DC Converter

FEATURES

- 2.5V to 5.5V Input Voltage Range
- 700mA Guaranteed Output Current
- Up to 95% Efficiency
- Low $R_{DS(ON)}$ Internal Switches: 280m Ω
- No Schottky Diode Required
- 100% Duty Cycle in Low Dropout Operation
- Operating Frequency: 1.5MHz
- Accurate Reference 0.6V Provides Low Output Voltages

APPLICATIONS

- LCD TV
- Multi-function Peripheral
- Cellular Phones
- CPU I/O Supplies
- Cordless Phones
- PDAs and Handy-Terminals
- Battery-Operated Devices (1 Li-Ion or 3 NiMH/ NiCd)

DESCRIPTION

The AIC2352 is a low-noise, pulse-width-modulated (PWM), DC-DC step-down converter. The device is available in an adjustable version and fixed output voltages of 1.0V, 1.2V, 1.8V, and 3.3V.

The device features an internal synchronous rectifier for high efficiency; it requires no external Schottky diode. The AIC2352 is ideally suited for Li-Ion battery applications. PWM/PSM mode extends battery life by switching to a pulse-skipping-modulated mode during light loads. Shutdown mode places the device in standby, reducing supply current to under 1 μ A.

Other features of the AIC2352 include high efficiency, low dropout voltage, short circuit protection, over temperature protection, and over voltage protection. It is available in a small 5 pins SOT-23 package.

APPLICATIONS CIRCUIT

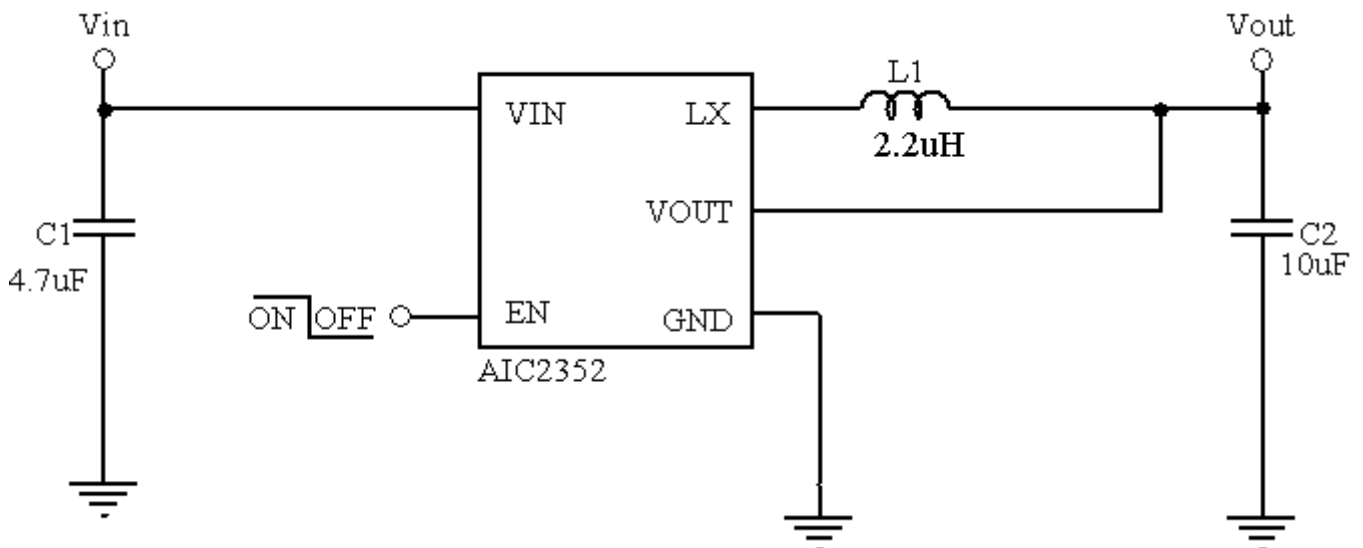


Fig. 1 Fixed Step-Down DC/DC Converter

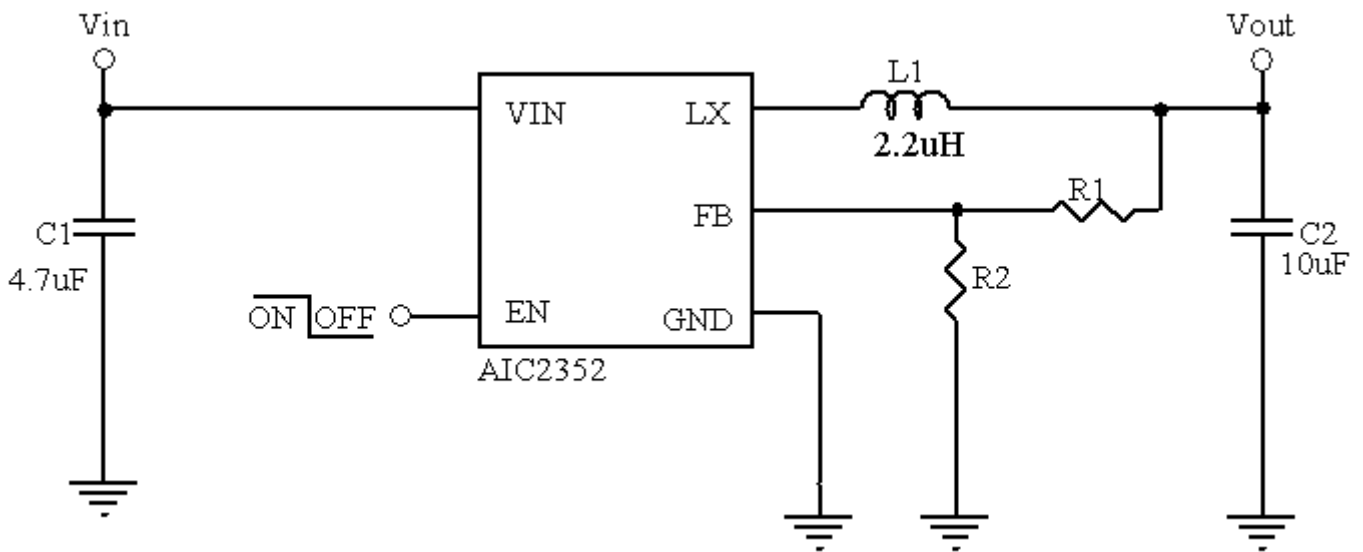


Fig. 2 Adjustable Step-Down DC/DC Converter

ORDERING INFORMATION

AIC2352-XX XXX XX

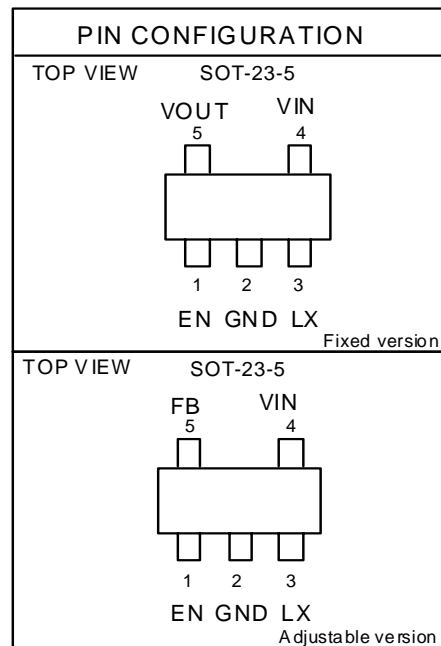
PACKING TYPE
TR: TAPE & REEL
BG: BAG

PACKAGE TYPE
V5: SOT-23-5

G: Green Package

OUTPUT VOLTAGE
DEFAULT: Adj.
10: 1.0V
12: 1.2V
18: 1.8V
33: 3.3V

Example: AIC2352-33GV5TR
 → 3.3V Output Version,
 in SOT-23-5 Green Package
 & Tape & Reel Packing Type
 AIC2352GV5TR
 → Adjustable Version,
 in SOT-23-5 Green Package
 & Tape & Reel Packing Type



■ ORDERING INFORMATION (Continuous)**● Marking (Fixed Version)**

Part No.	Marking
AIC2352-10GV5	HN10G
AIC2352-12GV5	HN12G
AIC2352-18GV5	HN18G
AIC2352-33GV5	HN33G

● Marking (Adjustable Version)

Part No.	Marking
AIC2352GV5	2352G

■ ABSOLUTE MAXIMUM RATINGS

VIN, LX Voltage	6V
EN, FB Pin Voltage	-0.3 V to VIN
Operating Ambient Temperature Range TA.....	-40°C to 85°C
Operating Maximum Junction Temperature TJ.....	150°C
Storage Temperature Range TSTG.....	-65°C to 150°C
Lead Temperature (Soldering 10 Sec.).....	260°C
Thermal Resistance Junction to Case SOT-23-5	115°C/W
Thermal Resistance Junction to Ambient SOT-23-5	250°C/W

(Assume no Ambient Airflow, no Heatsink)

Absolute Maximum Ratings are those values beyond which the life of a device may be impaired.

ELECTRICAL CHARACTERISTICS

 (T_A=25°C, V_{IN}=3.6V unless otherwise specified.) (Note 1)

PARAMETER	CONDITIONS	SYMBOL	MIN	TYP	MAX	UNITS
Input Voltage Range		V _{IN}	2.5		5.5	V
Output Adjustment Range		V _{OUT}	0.6V		V _{IN} -0.3V	V
Reference Voltage		V _{REF}	0.588	0.6	0.612	V
FB Input Current	V _{FB} = V _{IN}	I _{FB}	-50		50	nA
P-Channel On-Resistance	I _{OUT} = 0.2A	P _{RDS(ON)}		280	390	mΩ
N-Channel On-Resistance	I _{OUT} = 0.2A	N _{RDS(ON)}		250	390	mΩ
LX Leakage Current	V _{LX} =0V or V _{LX} =3.6V		-1		1	μA
Peak Inductor Current	V _{IN} = 5V	I _{PK}	0.9	1.1		A
Quiescent Current	I _{OUT} = 0mA, V _{FB} =V _{REF} + 5%	I _Q		65	85	μA
Shutdown Supply Current	EN = GND	I _{SHDN}		0.1	1	μA
EN High-Level Input Voltage	V _{IN} =2.5V to 5.5V	V _{EN_H}	1.5			V
EN Low-Level Input Voltage	V _{IN} =2.5V to 5.5V	V _{EN_L}			0.4	V
Oscillator Frequency		f _{OSC}	1.2	1.5	1.8	MHz
Maximum Duty Cycle		D _{MAX}	100			%
Thermal Shutdown Temperature				150		°C
Thermal Shutdown Hysteresis				25		°C

Note 1: Specifications are production tested at T_A=25°C. Specifications over the -40°C to 85°C operating temperature range are assured by design, characterization and correlation with Statistical Quality Controls (SQC).

TYPICAL PERFORMANCE CHARACTERISTICS

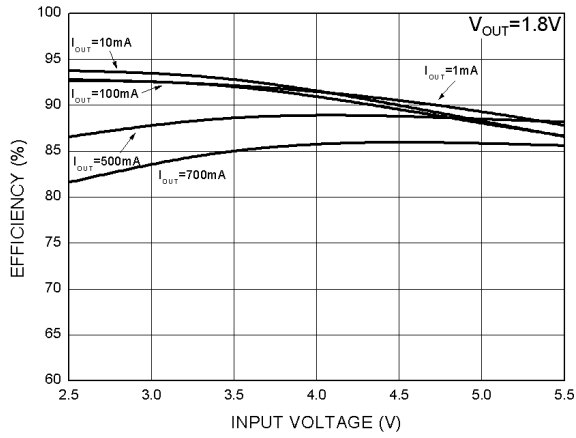


Fig. 3 Efficiency vs. Input Voltage

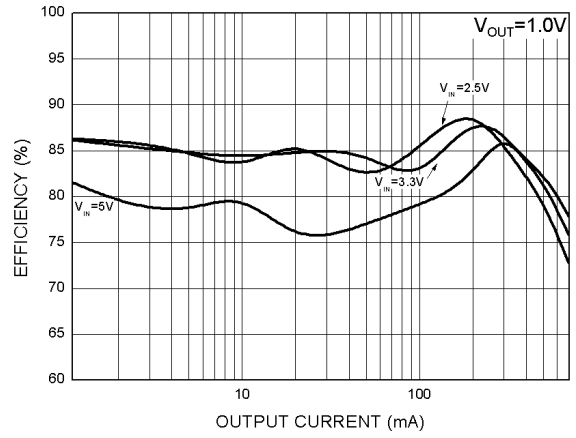


Fig. 4 Efficiency vs. Output Current

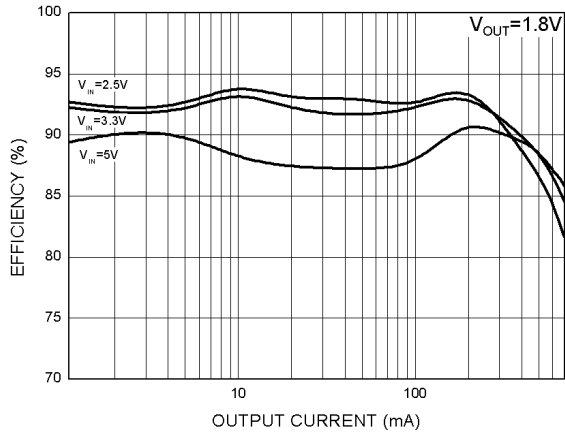


Fig. 5 Efficiency vs. Output Current

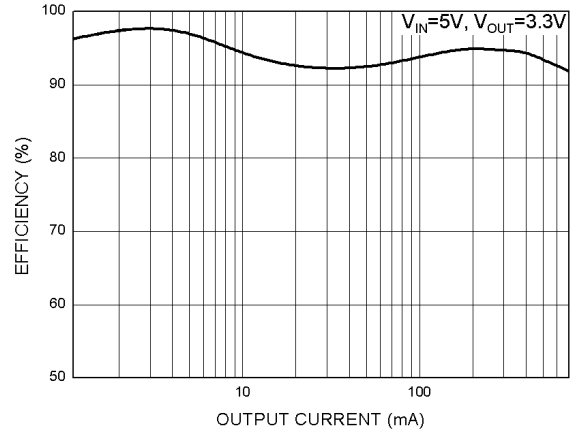


Fig. 6 Efficiency vs. Output Current

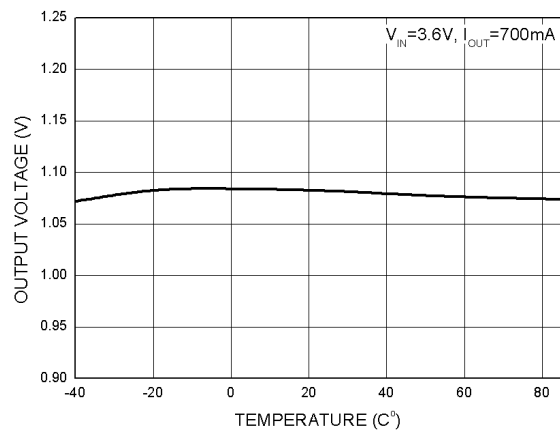


Fig. 7 Output Voltage vs. Temperature

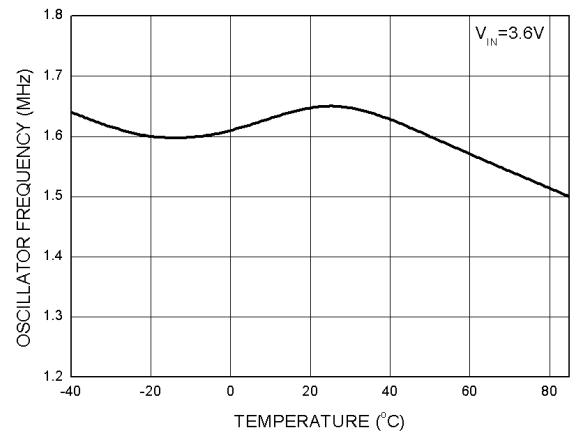


Fig. 8 Oscillator Frequency vs. Temperature

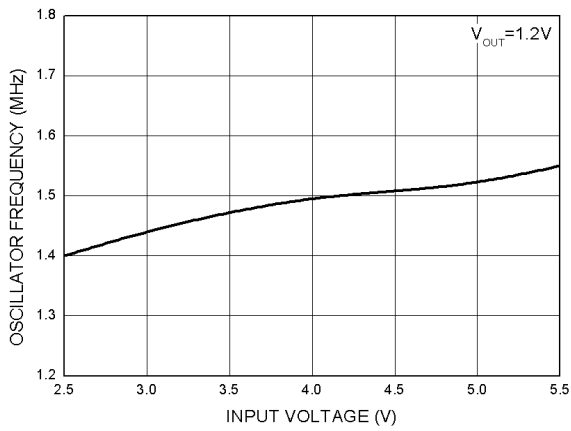
■ TYPICAL PERFORMANCE CHARACTERISTICS (Continuous)


Fig. 9 Oscillator Frequency vs. Input Voltage

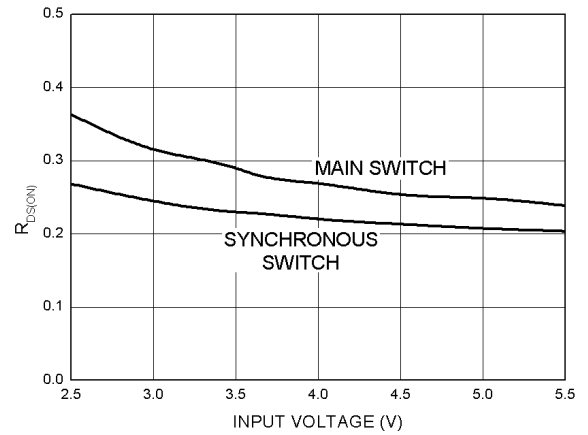
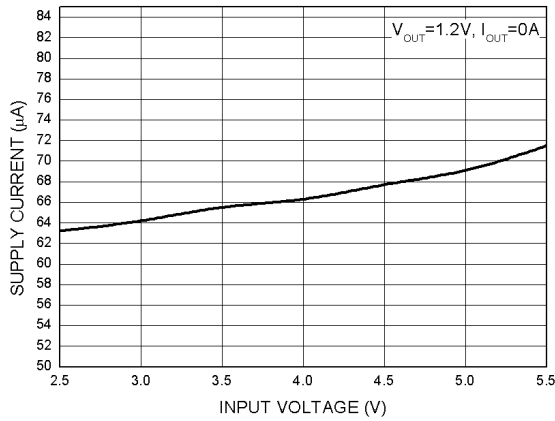

 Fig. 10 $R_{DS(ON)}$ vs. Input Voltage


Fig. 11 Supply Current vs. Input Voltage

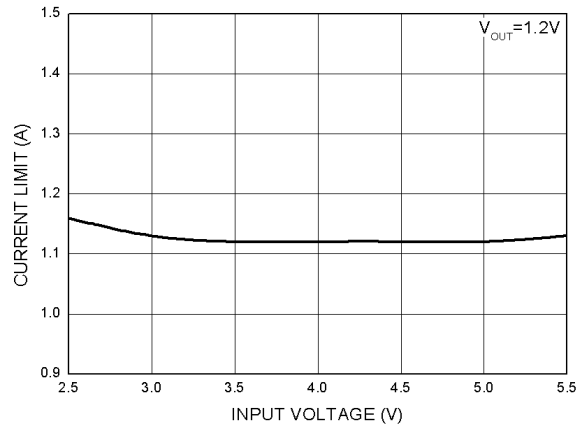


Fig. 12 Current Limit vs. Input Voltage

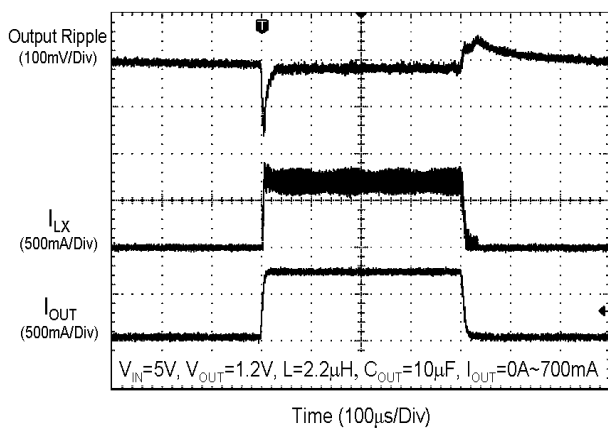


Fig. 13 Load Transient Response

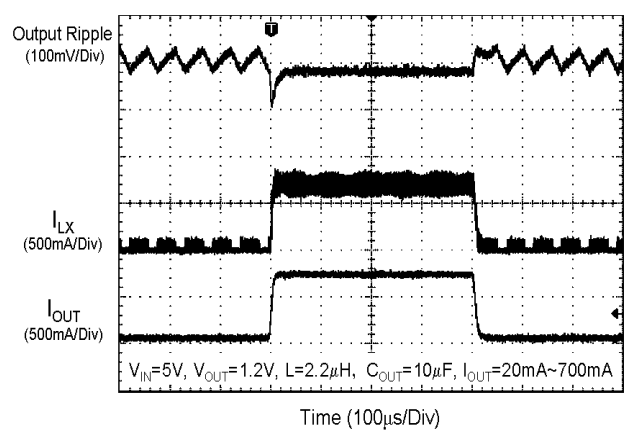


Fig. 14 Load Transient Response

■ TYPICAL PERFORMANCE CHARACTERISTICS (Continuous)

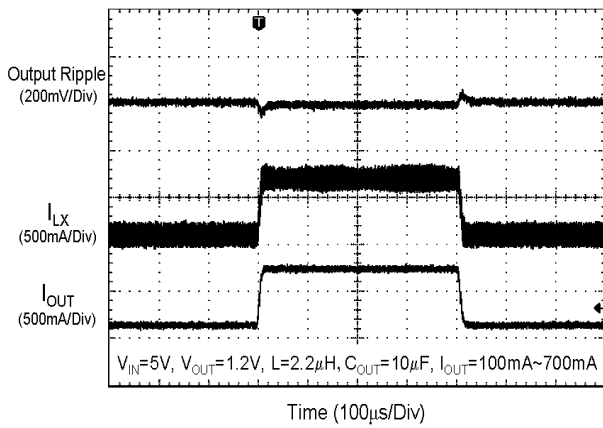


Fig. 15 Load Transient Response

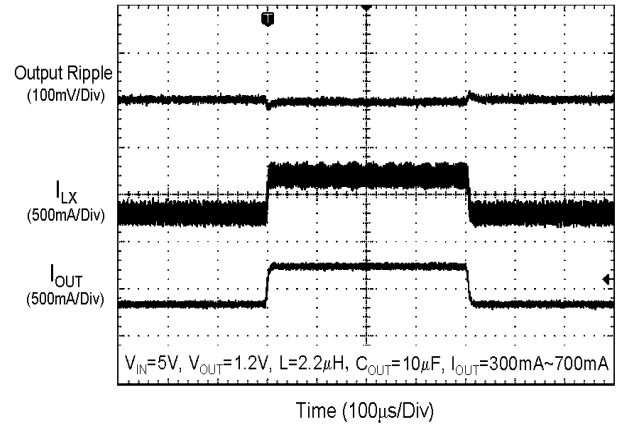


Fig. 15 Load Transient Response

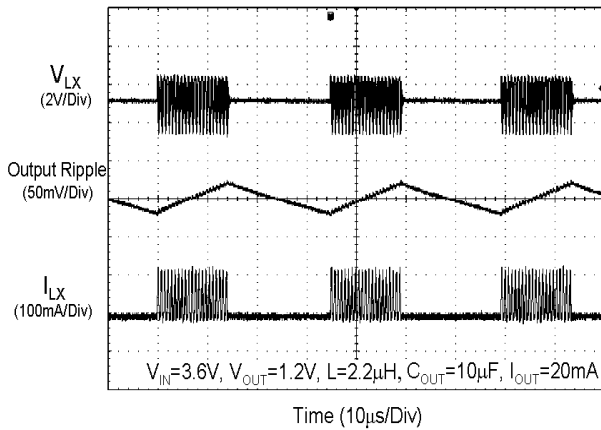
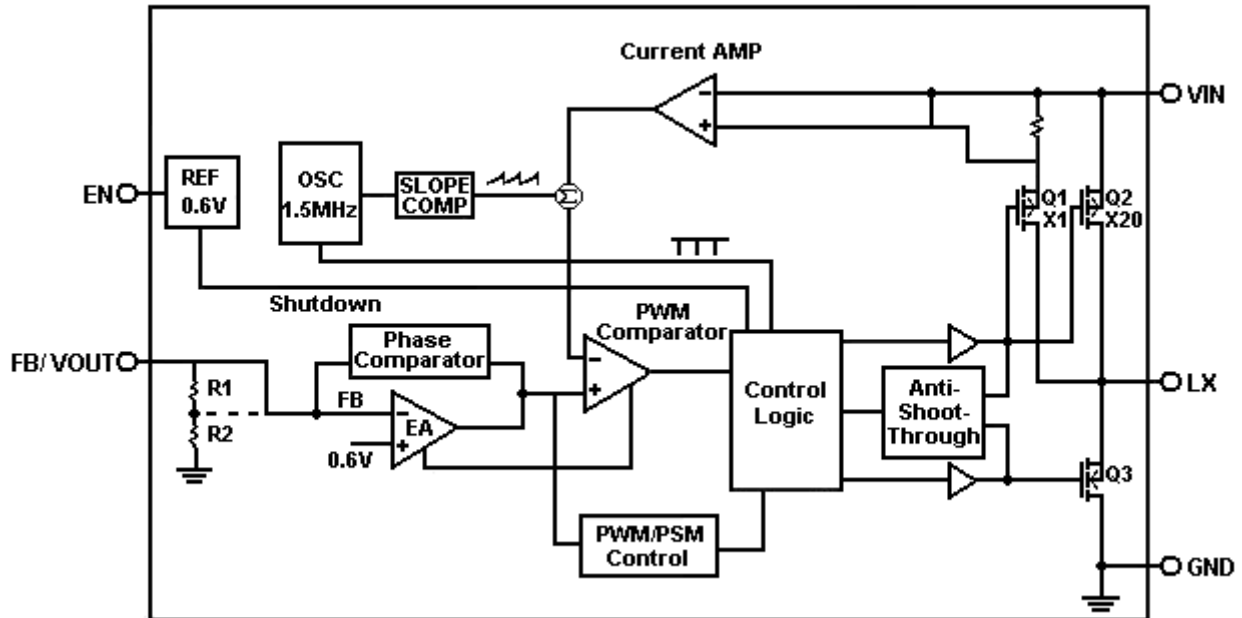


Fig. 17 PSM Operation

■ BLOCK DIAGRAM



Functional Block Diagram of AIC2352

■ PIN DESCRIPTIONS

Pin Name	Pin Function
NC	No Internal Connect (Floating or Connecting to GND).
EN	Chip Enable (Active High).
VIN	Power Input.
LX	Pin for Switching.
GND	Ground.
FB/VOUT	Feedback/Output Voltage Pin.

■ APPLICATION INFORMATION

Operation

The AIC2352 is a low-noise step-down DC/DC converter with current-mode PWM/PSM control architecture. It features an internal synchronous rectifier, which eliminates the external Schottky diode and increases efficiency. During normal operation, the AIC2352 can regulate its output voltage through a feedback control circuit, which is composed of an error amplifier; a current comparator and several control signal generators. By comparing the feedback voltage to the reference voltage of 0.6V, the error amplifier varies its output voltage. The output voltage of the error amplifier is compared with the summing signal of current sensing signal and slope compensation signal to determine the duty cycle of internal main power switch (P-channel MOSFET). While the main power switch is turned on, the synchronous power switch (N-channel MOSFET) will be turned off through anti-short-through block. Similarly, when the main power switch is turned off, the synchronous power switch will be turned on until the inductor current starts to reverse or the beginning of the next switching cycle. In order to achieve better efficiency and prevent overcharging the output capacitor, AIC2352 will enter pulse-skipping-modulated mode (PSM) operation while working at light load conditions.

Current Limitation

The AIC2352 provides current limit function by using an internal sensing resistor. When the main power switch turns on, current follows through the internal sensing resistor. And current amplifier senses the voltage, which crosses the resistor, and amplifies it. While the sensed voltage gets higher than reference voltage, the current limitation function is activated. While the current limitation function is activated, the duty cycle will be reduced to limit the output power to protect the internal power switches.

Short Circuit Protection

While the output is shorted to ground, the switching frequency of AIC2352 will be reduced to one third of the normal switching frequency. This lower switching frequency ensures the inductor current has more time to discharge, thereby preventing inductor current runaway. The switching frequency will automatically return to its designed value while short circuit condition is released.

Shutdown

By connecting the EN pin to GND, the AIC2352 can be shut down to reduce the supply current to 0.1 μ A (typical). At this operation mode, the output voltage of step-down converter is equal to 0V.

100% Duty Cycle Operation

When the input voltage approaches the output voltage, the AIC2352 smoothly transits to 100% duty cycle operation. This allows AIC2352 to regulate the output voltage until AIC2352 completely enters 100% duty cycle operation. In 100% duty cycle mode, the output voltage is equal to the input voltage minus the voltage, which is the drop across the main power switch.

The AIC2352 achieves 100% duty cycle operation by extending the turn-on time of the main power switch. If the summing signal of current sensing signal and slope compensation signal does not reach the output voltage level of the error amplifier at the end of 90% switching period, the main power switch is continuously turned on and the oscillator remains off until the summing signal of current sensing signal and slope compensation signal reaches the output voltage level of the error amplifier. After the summing signal of current sensing signal and slope compensation signal reaches the output voltage level of the error amplifier, the main power switch is turned off and the synchronous power switch is turned on for a constant off time. At the end of the constant off time, the next

switching cycle is begun. While the input voltage approaches the output voltage, the switching frequency decreases gradually to smoothly transit to 100% duty cycle operation.

If input voltage is very close to output voltage, the switching mode goes from pure PWM mode to 100% duty cycle operation. During this transient state mentioned above, large output ripple voltage may appear on output terminal.

Components Selection

Inductor

The inductor selection depends on the current ripple of inductor, the input voltage and the output voltage.

$$L \geq \frac{V_{OUT}}{f_{OSC} \cdot \Delta I_L} \left(1 - \frac{V_{OUT}}{V_{IN}} \right)$$

Accepting a large current ripple of inductor allows the use of a smaller inductance. However, higher current ripple of inductor can cause higher output ripple voltage and large core loss. By setting an acceptable current ripple of inductor, a suitable inductance can be obtained from above equation.

In addition, it is important to ensure the inductor saturation current exceeds the peak value of inductor current in application to prevent core saturation. The peak value of inductor current can be calculated according to the following equation.

$$I_{PEAK} = I_{OUT(max)} + \frac{V_{OUT}}{2 \times f_{OSC} \cdot L} \left(1 - \frac{V_{OUT}}{V_{IN}} \right)$$

Input Capacitor and Output Capacitor

To prevent the high input voltage ripple and noise resulted from high frequency switching, the use of low ESR ceramic capacitor for the maximum RMS current is recommended. The approximated RMS current of the input capacitor can be calculated according to the following equation.

$$I_{CINRMS} \approx \sqrt{I_{OUT(MAX)}^2 \times \frac{V_{OUT}(V_{IN} - V_{OUT})}{V_{IN}^2} + \frac{\Delta I_L^2}{12}}$$

The selection of output capacitor depends on the required output voltage ripple. The output voltage ripple can be expressed as:

$$\Delta V_{OUT} = \frac{\Delta I_L}{8 \times f_{OSC} \cdot C_{OUT}} + ESR \cdot \Delta I_L$$

For lower output voltage ripple, the use of low ESR ceramic capacitor is recommended. The tantalum capacitor can also be used well, but its ERS is larger than that of ceramic capacitor.

When choosing the input and output ceramic capacitors, X5R and X7R types are recommended because they retain their capacitance over wider ranges of voltage and temperature than other types.

Output Voltage Programming (AIC2352 Adjustable Version Only)

By connecting a resistive divider R_1 and R_2 , the output voltage of AIC2352 step-down converter can be set.

V_{OUT} can be calculated as:

$$V_{OUT} = 0.6 \times \left(1 + \frac{R_1}{R_2} \right)$$

The resistive divider should sit as close to VFB pin as possible.

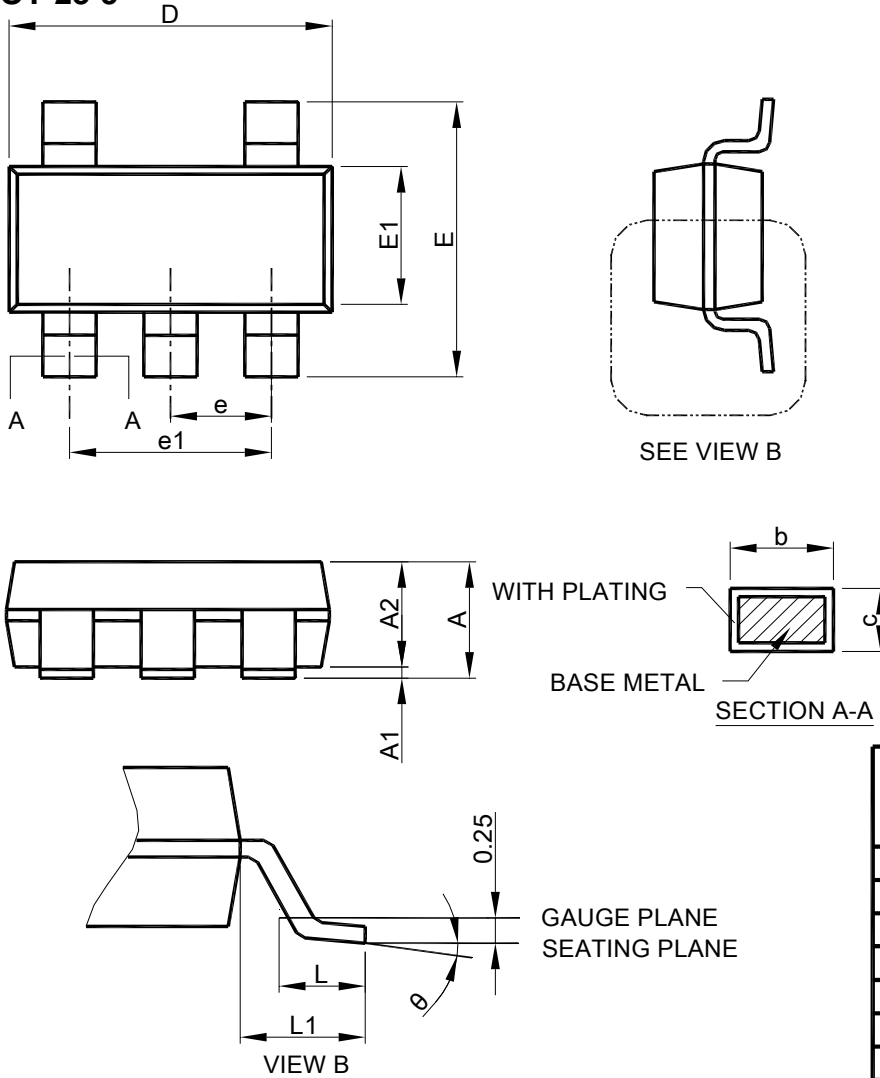
Layout Consideration

In order to ensure a proper operation of AIC2352, the following points should be managed comprehensively.

1. The input capacitor and V_{IN} should be placed as close as possible to each other to reduce the input voltage ripple and noise.
2. The output loop, which is consisted of the inductor, the internal main power switch, the internal synchronous power switch and the output capacitor, should be kept as small as possible.
3. The routes with large current should be kept short and wide.
4. Logically the large current on the converter should flow at the same direction.
5. The VFB pin should be connected to the feedback resistors directly and the route should be away from the noise sources.

PHYSICAL DIMENSIONS

● SOT-23-5



- Note :
1. Refer to JEDEC MO-178AA.
 2. Dimension "D" does not include mold flash, protrusions or gate burrs. Mold flash, protrusion or gate burrs shall not exceed 10 mil per side.
 3. Dimension "E1" does not include inter-lead flash or protrusions.
 4. Controlling dimension is millimeter, converted inch dimensions are not necessarily exact.

SYMBOL	SOT-23-5	
	MILLIMETERS	
	MIN.	MAX.
A	0.95	1.45
A1	0.00	0.15
A2	0.90	1.30
b	0.30	0.50
c	0.08	0.22
D	2.80	3.00
E	2.60	3.00
E1	1.50	1.70
e	0.95 BSC	
e1	1.90 BSC	
L	0.30	0.60
L1	0.60 REF	
θ	0°	8°

Note:

Information provided by AIC is believed to be accurate and reliable. However, we cannot assume responsibility for use of any circuitry other than circuitry entirely embodied in an AIC product; nor for any infringement of patents or other rights of third parties that may result from its use. We reserve the right to change the circuitry and specifications without notice.

Life Support Policy: AIC does not authorize any AIC product for use in life support devices and/or systems. Life support devices or systems are devices or systems which, (i) are intended for surgical implant into the body or (ii) support or sustain life, and whose failure to perform, when properly used in accordance with instructions for use provided in the labeling, can be reasonably expected to result in a significant injury to the user.