

NAN YA PLASTICS CORPORATION

SPECIFICATION OF
LCD MODULE
PRODUCT NO.: LCCFBTB61M77S

SPEC. NO: LMB61-77A-

CUSTOMER
APPROVED BY
DATE:

LCD DEPARTMENT
ELECTRONIC MATERIALS DIVISION
NAN YA PLASTICS CORPORATION
201, TUNG HWA N. ROAD, TAIPEI
TEL: 886-2-27122211 EXT. 5993~5995
FAX: 886-2-27178253
E-mail: lcdsales@npc.com.tw

EDITED ON : Sep. 12. 2006

Q.C. DEPT.	DESIGN MANAGER	DESIGN CHECK	DESIGNER
			W.R.HSU

1. MECHANICAL DATA

NO	ITEM	CONTENTS	UNIT
1	Product No.	LCCFBTB61M77S	-
2	Module Size	154.6 (W) x 114.8 (H) x 10.6 (D)	mm
3	Dot Size	0.10 (W) x 0.34 (H)	mm
4	Dot Pitch	0.12 (W) x 0.36 (H)	mm
5	Number of Dots	320 x RGB (W) x 240 (H)	Dot
6	Duty	1/240	-
7	LCD Display Mode	FSTN, Color STN Module	-
8	Rear Polarizer	Color Transmissive Type	-
9	Viewing Direction	6	O'clock
10	Backlight	LED	-
11	Controller	Excluded	-
12	DC/DC Converter	Excluded	-
13	Touch Panel	Included	-
14	Weight	230 (Approx.)	g

Note :

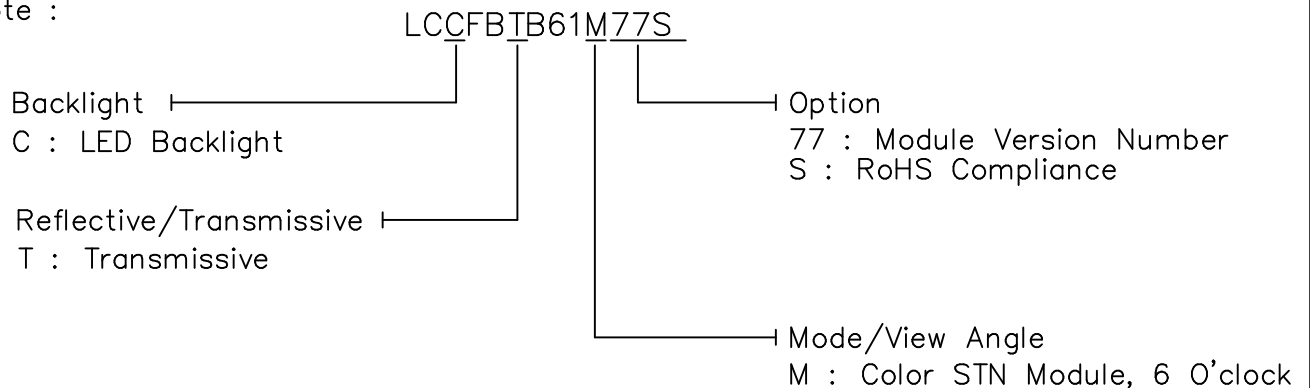

RoHS Compliance.

Nan Ya guarantees that this project doesn't include any materials (6 materials) or includes less than specified quantities which are regulated by RoHS Compliance.

REV/DATE	R0/ 09.12.06'					BY W.R.HSU
----------	------------------	--	--	--	--	---------------

2. ABSOLUTE MAXIMUM RATINGS

(1) ELECTRICAL ABSOLUTE RATINGS

VSS=0V

	SYMBOL	MIN.	MAX.	UNIT	COMMENT
Power Supply for Logic	VDD-VSS	-0.3	5.5	V	
Input Voltage	VI	-0.3	VDD	V	
Static Electricity	-	-	-	-	Note 1

Note 1 LCM should be grounded during handling LCM.

(2) ENVIRONMENTAL ABSOLUTE MAXIMUM RATINGS

ITEM	WIDE TEMP.			
	OPERATING		STORAGE	
	MIN.	MAX.	MIN.	MAX.
Ambient Temperature	-20	70	-40	80
Humidity (Without Condensation)	Note 2,4		Note 3,4	

Note 2 $T_a \leq 70^\circ\text{C}$: 75%RH max

Note 3 Please refer to item of reliability test

Note 4 Background color will change slightly depending on ambient temperature.
That phenomenon is reversible.

Note 5

Frequency	5 Hz~13.95 Hz	13.95 Hz~33 Hz	33 Hz~51 Hz	51 Hz~500 Hz
Vibration Level	-	2x9.8 m/s ²	-	5x9.8 m/s ²
Vibration Width	0.2 inch	-	0.036 inch	-
Vibration Direction	X/Y/Z			
Vibration Time	20 min/cycle X 3 directions			

3. ELECTRICAL CHARACTERISTICS

3-1. ELECTRICAL CHARACTERISTICS OF LCM

ITEM	SYMBOL	CONDITION		MIN.	TYP.	MAX.	UNIT
Power Supply for Logic	VDD-VSS	-		4.5	5.0	5.5	V
Power Supply for Logic	VDD-VSS	-		2.7	3.0	3.3	V
Input Voltage	VIH	H level		0.8VDD	-	VDD	V
	VIL	L level		0	-	0.2VDD	
Recommended LC Driving Voltage	VEE-VSS (Vop)	Duty= 1/240	-20°C	27.0	27.4	27.8	V
			0°C	26.2	26.6	27.0	
			25°C	25.2	25.6	26.0	
			50°C	24.1	24.5	24.9	
			70°C	23.5	23.9	24.3	
Power Supply Current	IDD	VDD-VSS=3V/5V VEE-VSS=25.6V Ta=25°C Pattern:		-	4	6	mA
	IEE			-	8	12	
Surface Luminance of LCM	L	VAK = 5V Pattern: Dots All ON		50	70	-	cd/m ²
		VAK = 5V Pattern: Dots All OFF		-	5	-	
Recommended Frame Frequency for Optimum Cocontrast	FLM	-		115	120	125	Hz

3-2.ELECTRICAL CHARACTERISTICS OF BACKLIGHT

Used LED Rating (Constant Voltage Driving)

Temp.=25°C

ITEM	SYMBOL	MIN.	TYP.	MAX.	UNIT	REMARK
Peak forward current	I_P	-	-	300	mA	-
Maximum reverse voltage	V_R	-	-	5	V	-
Applied forward voltage	V_{AK}	-	5	-	V	-
Applied forward current	I_{AK}	-	-	240	mA	-
LED power consumption	P_F	-	-	1.2	W	-
LED life time	L_L	-	10000	-	hrs	at $V_{AK} = 5 \text{ V}$ (*1)

(*1) LED life time is defined as follows : The final brightness is at 50% of original brightness.

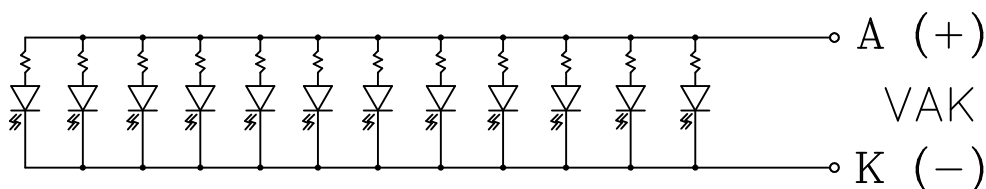

3-3.CHARACTERISTICS OF TOUCH PANEL

Used Touch Panel Rating

Temp.=25°C

ITEM	SYMBOL	CONDITION	MIN.	TYP.	MAX.	UNIT
Applied Rating Voltage	V_R	—	—	—	7.0	V
Operating Temperature	T_{OPR}	20%~85% R.H. Max. Avoid Dew Condensation at Any Time	-5	—	60	°C
Storage Temperature	T_{STO}		-30	—	70	
Resistance of Terminal Electrodes	R_{ETD}	X Electrode	300	—	900	Ω
		Y Electrode	200	—	600	
Linearity	L	—	—	—	1.5	%
Insulation Resistance	R_{OFF}	$V_{DC}=25V$	10	—	—	M Ω
Transparency	T	According to JIS-K7015	—	80	—	%
Surface Hardness	S_H	According to JIS-K5400	3	—	—	H

Test condition : Touch panel is placed horizontally in a vessel and no power is supplied to T/P.
Normal state is temperature : $25\pm 10^\circ\text{C}$, relative humidity : $60\pm 25\%$

4. OPTICAL CHARACTERISTICS

4-1. Optical Char. of Wide Temp. Mode

AT V_{OP}

ITEM MODE		Cr(Contrast Ratio)										θ (Viewing Angle)		θ (Viewing Angle)	
		-20°C		0°C		25°C		50°C		70°C		25°C		25°C	
		MIN.	TYP.	MIN.	TYP.	MIN.	TYP.	MIN.	TYP.	MIN.	TYP.	MIN.	TYP.	MIN.	TYP.
T	M	12	18	14	20	17	25	3.5	5	1.4	2	-	F: >60 R: 30	-	L: 55 R: 55
NOTE		NOTE 6										NOTE 5			

NOTE :

T : Transmissive

M : Color STN Module, 6 O'clock

AT $\phi=0^\circ$ $\theta=0^\circ$

ITEM	SYMBOL	CONDITION	MIN.	TYP.	MAX.	UNIT	NOTE
Response Time (rise)	Tr	-20°C	2300	2900	4300	ms	NOTE 2
		0°C	640	800	1200		
		25°C	240	300	450		
		50°C	80	100	150		
		70°C	45	55	80		
Response Time (fall)	Tf	-20°C	1500	1800	2700	ms	NOTE 2
		0°C	360	450	670		
		25°C	80	100	150		
		50°C	48	60	90		
		70°C	32	40	60		

4-2. Color of CIE Coordinate

Ta = 25°C

ITEM		SYMBOL	CONDITION	VALUE	NOTE
Color of CIE Coordinate	Red	X	$\phi=0^\circ, \theta=0^\circ$	0.53	Note*
		y		0.33	
	Green	X	$\phi=0^\circ, \theta=0^\circ$	0.31	
		y		0.52	
	Blue	X	$\phi=0^\circ, \theta=0^\circ$	0.16	
		y		0.12	
	White	X	$\phi=0^\circ, \theta=0^\circ$	0.30	
		y		0.31	

Note* Measuring at position 3 on Fig.1
 CIE chromaticity diagram

Tolerance : ± 0.05

Fig.1

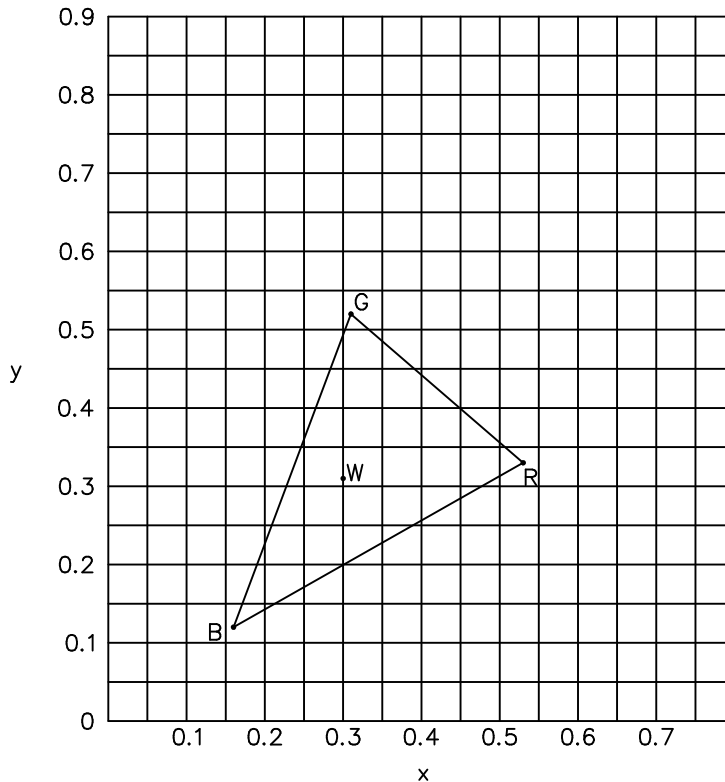

(NOTE 1)

Definition of Operation Voltage(Vop)

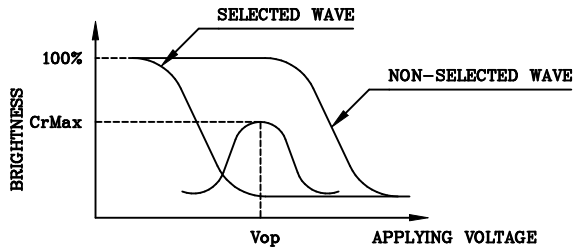

(positive type)

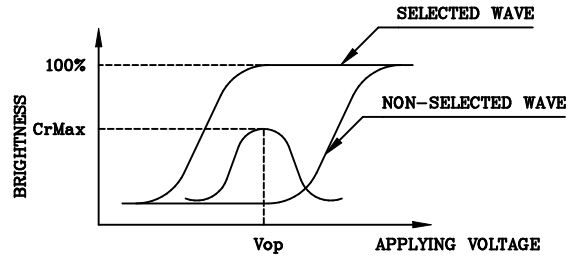

(negative type)

*Conditions

Viewing Angle : 0
Frame Frequency : 120Hz
Applying Waveform : 1/N duty 1/a bias

(NOTE 2)

Definition of Response Time(Tr,Tf)

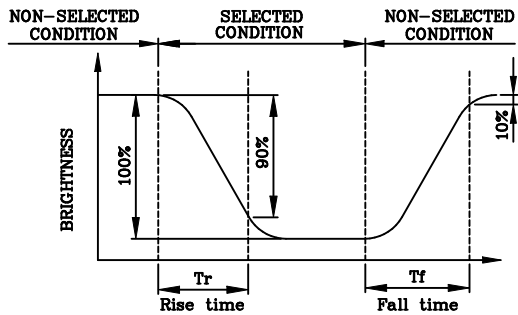

(positive type)

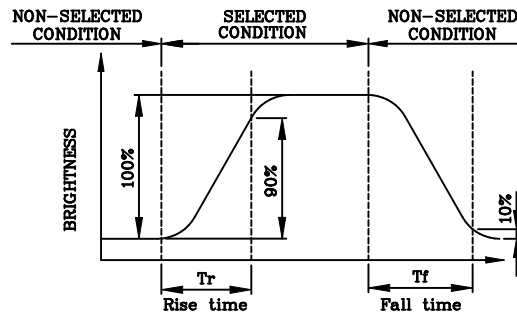

(negative type)

*Conditions

Operating Voltage : Vop
Viewing Angle (θ,φ) : (0,0)
Frame Frequency : 120Hz
Applying Waveform : 1/N duty 1/a bias

(NOTE 3)

Description of Measuring Equipment and Driving Waveforms

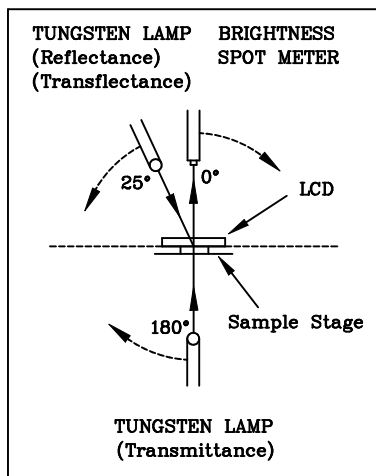

Multiplex Driving (1/N duty 1/a bias)

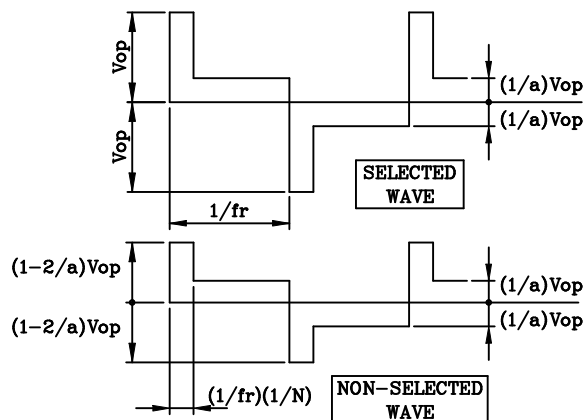

(NOTE 4)

Definition of Viewing Direction

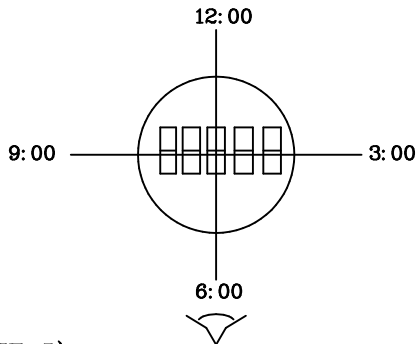

(NOTE 5)

Definition of Viewing Angle

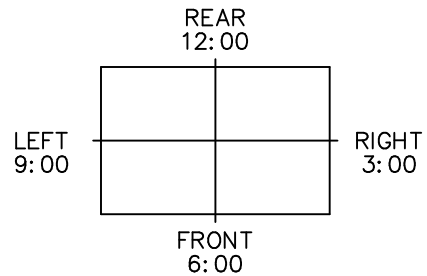
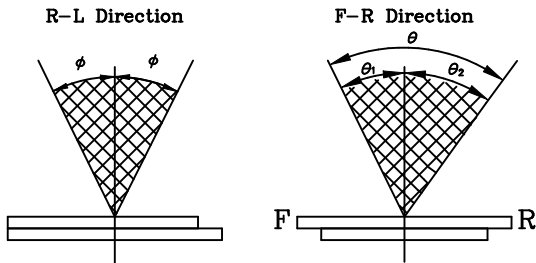

*For This Product
 The Viewing Direction Is 6 O'clock
 So $\theta_1 > \theta_2$

$$\theta = \theta_1 + \theta_2$$

*Conditions

Operating Voltage : V_{op}
 Frame Frequency : 120Hz
 Applying Waveform : 1/N duty 1/a bias
 Contrast Ratio : larger than 2

(NOTE 6)

Definition of Contrast Ratio (Cr)

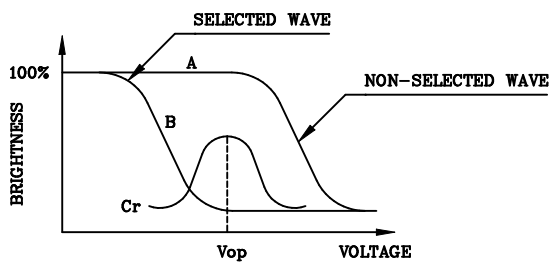

(positive type)

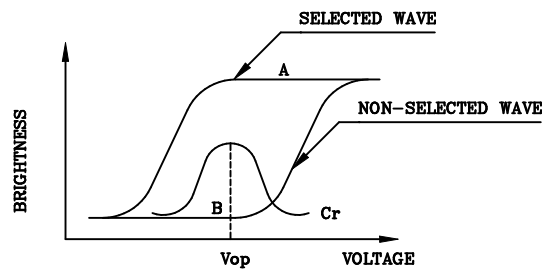

(negative type)

$$\text{Contrast Ratio : } Cr = A/B$$

*Conditions

Viewing Angle : 0
 Frame Frequency : 120Hz
 Applying Waveform : 1/N duty 1/a bias

5. BLOCK DIAGRAM

LCD

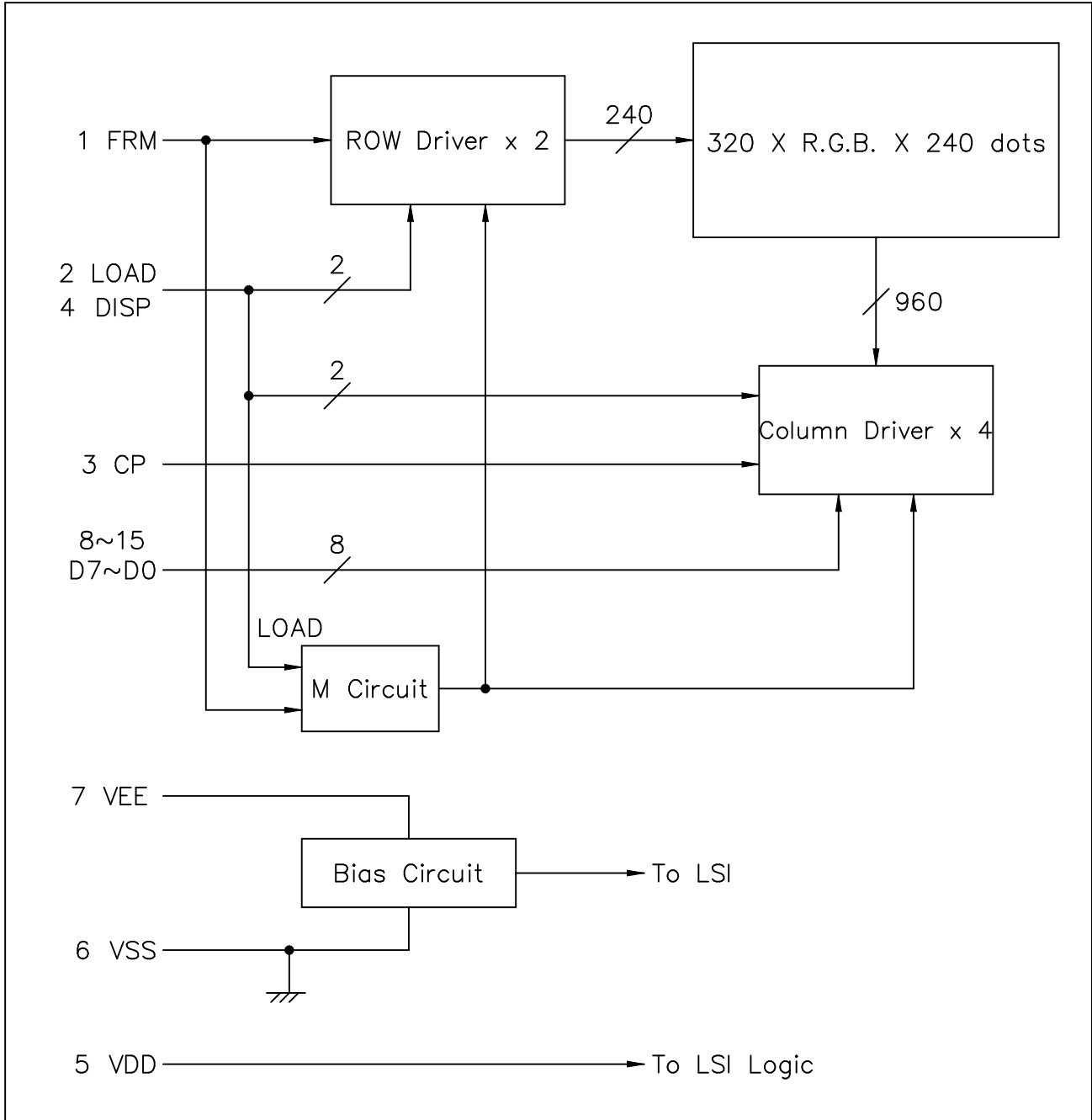

LED

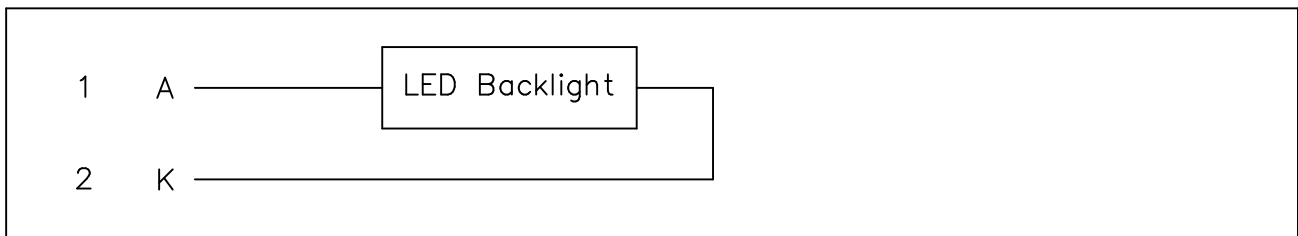

6. INTERNAL PIN CONNECTION

LCD

Pin No.	Symbol	Function	Level
1	FRM	Synchronous signal for driving scanning line	H
2	LOAD	Data signal latch clock	H → L
3	CP	Data signal shift clock	H → L
4	DISP	Display control signal	H(ON),L(OFF)
5	VDD	Power supply for logic	—
6	VSS	GND	—
7	VCON	Power supply for LCD	—
8	D7	Display data	H(ON),L(OFF)
9	D6		
10	D5		
11	D4		
12	D3		
13	D2		
14	D1		
15	D0		

CN1 : 53261-1571 (Molex)

Recommended Matching Connector : 51021-1500(Molex) or Compatible

LED

Pin No.	Symbol	Function	Level
1	A	Power supply for LED Backlight (+)	—
2	K	Power supply for LED Backlight (-)	—

CN2 : BHR-02VS-1 (JST)

Recommended Matching Connector : SM02(4.0)B-BHS-1-TB(JST) or Compatible

TOUCH SCREEN

Pin No.	Symbol	Level	Function
1	DOWN	—	Down Direction
2	LEFT	—	Left Direction
3	UP	—	Up Direction
4	RIGHT	—	Right Direction

TOUCH SCREEN CABLE : N4,Pitch 1.0mm(Thickness = 0.3 mm)

Recommended Matching Connector : 52852-0470(molex)

7. POWER SUPPLY

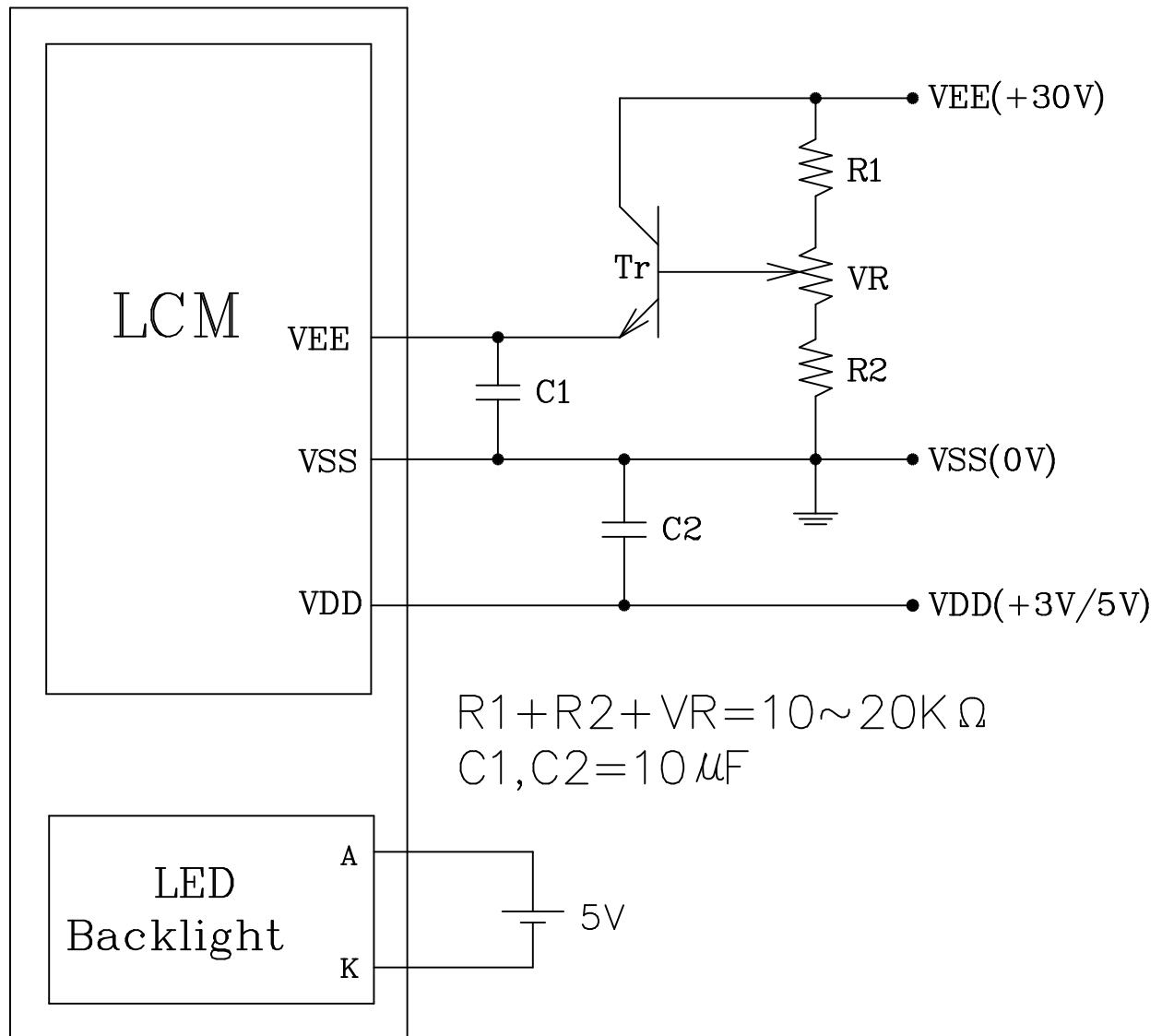

8. TIMING CHARACTERISTICS

8-1. INTERFACE TIMING

VDD=3.3V ± 10%

Parameter	SYMBOL	MIN.	MAX.	UNIT
CLOCK PULSE CYCLE TIME	t_{wck}	66	—	ns
CLOCK PULSE HIGH LEVEL WIDTH	t_{wckH}	23	—	ns
CLOCK PULSE LOW LEVEL WIDTH	t_{wckL}	23	—	ns
LATCH PULSE HIGH LEVEL WIDTH	t_{wLPH}	30	—	ns
CP→LP RISE TIME	t_{LD}	10	—	ns
CP→LP FALL TIME	t_{SL}	30	—	ns
LP→CP RISE TIME	t_{LS}	30	—	ns
LP→CP FALL TIME	t_{LH}	30	—	ns
CLOCK PULSE RISE/FALL TIME	t_r, t_f	—	30	ns
DATA SETUP TIME	t_{DS}	10	—	ns
DATA HOLD TIME	t_{DH}	25	—	ns
DISPOFF LOW LEVEL WIDTH	t_{WDL}	1.2	—	μs
DISPOFF CANCELLATION TIME	t_{SD}	100	—	ns

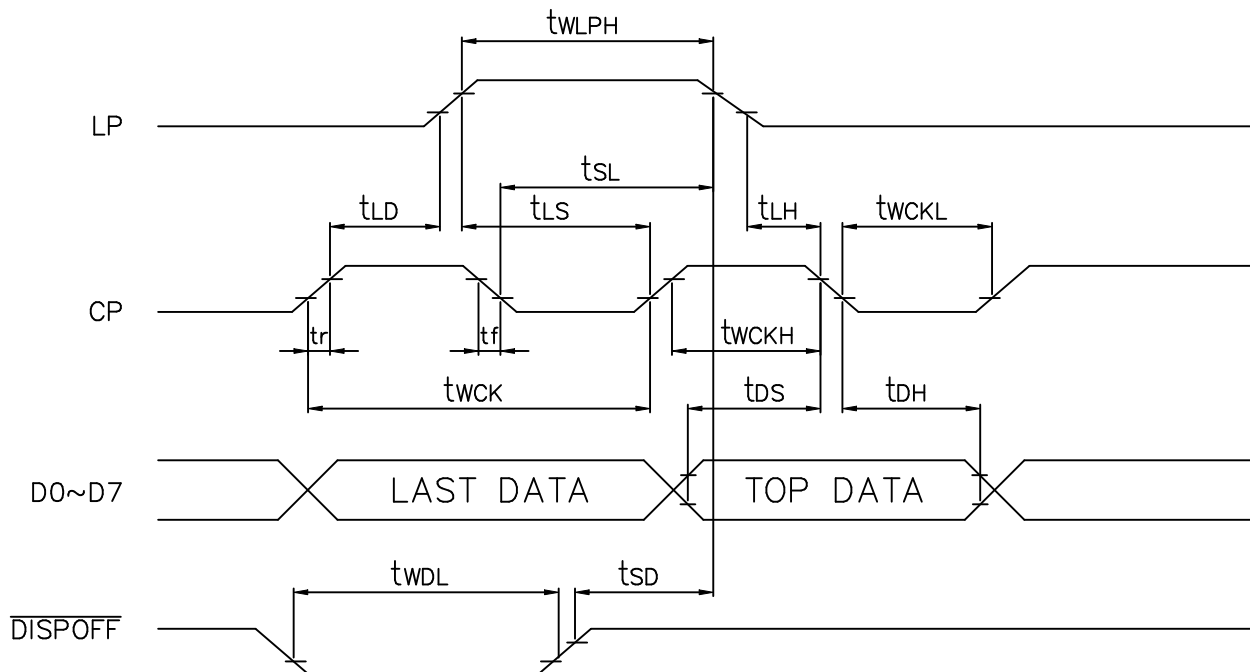

8-2. TIMING CHART

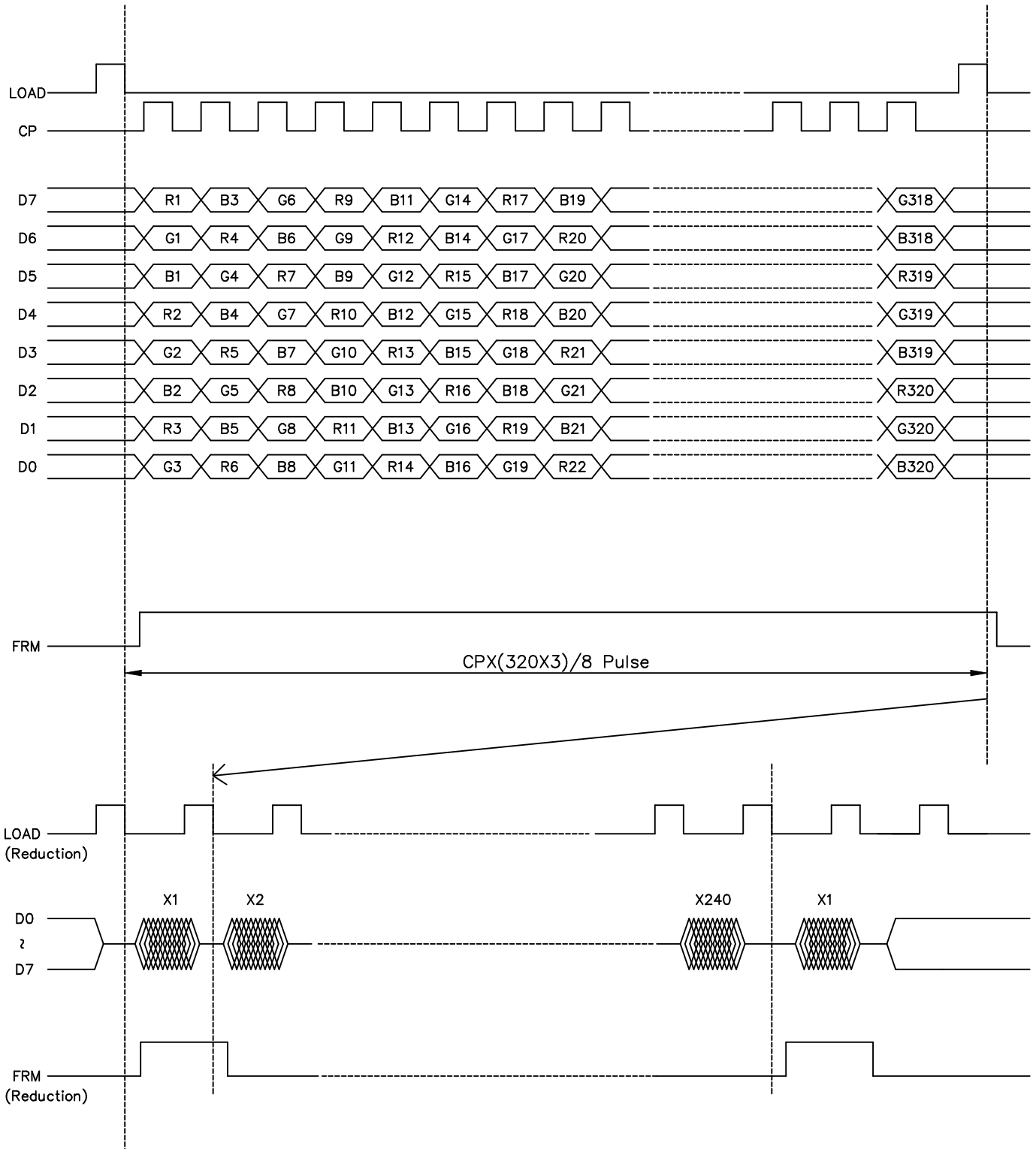

8-3. POWER ON/OFF TIMING

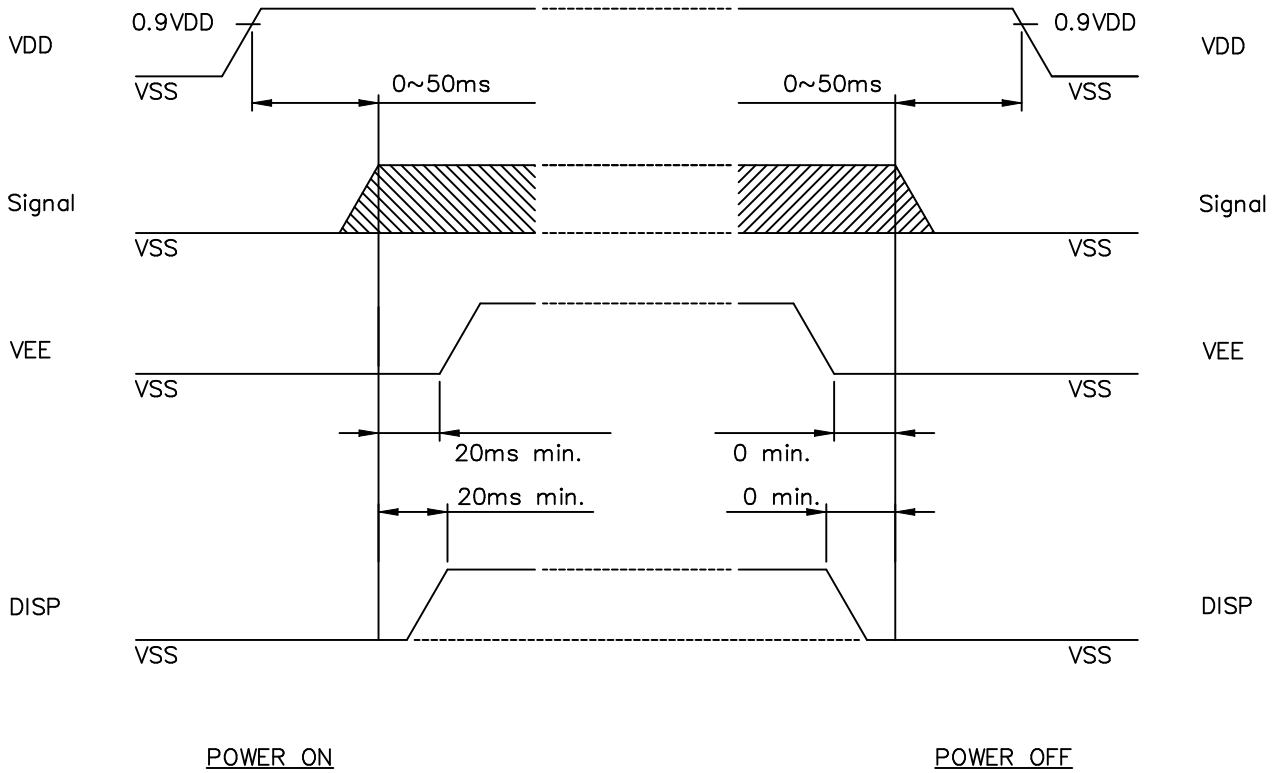

The missing pixels may occur when the LCM is driven beyond above power interface timing sequence.

8-4.DISPLAY PATTERN

START DATA

	Y1			Y2			Y3			Y318			Y319			Y320		
X1	R1	G1	B1	R2	G2	B2	R3	G3	B3	R318	G318	B318	R319	G319	B319	R320	G320	B320
	D7	D6	D5	D4	D3	D2	D1	D0	D7	D0	D7	D6	U5	D4	D3	D2	D1	D0
X2	R1	G1	B1	R2	G2	B2	R3	G3	B3	R318	G318	B318	R319	G319	B319	R320	G320	B320
	D7	D6	D5	D4	D3	D2	D1	D0	D7	D0	D7	D6	U5	D4	D3	D2	D1	D0
X239	R1	G1	B1	R2	G2	B2	R3	G3	B3	R318	G318	B318	R319	G319	B319	R320	G320	B320
	D7	D6	D5	D4	D3	D2	D1	D0	D7	D0	D7	D6	U5	D4	D3	D2	D1	D0
X240	R1	G1	B1	R2	G2	B2	R3	G3	B3	R318	G318	B318	R319	G319	B319	R320	G320	B320
	D7	D6	D5	D4	D3	D2	D1	D0	D7	D0	D7	D6	U5	D4	D3	D2	D1	D0

9. RELIABILITY TEST

WIDE TEMPERATURE RELIABILITY TEST

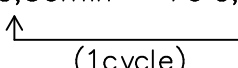
NO	ITEM	CONDITION			STANDARD	NOTE
1	High Temp. Storage	80°C	120Hrs		Appearance without defect	
2	Low Temp. Storage	-40°C	120Hrs		Appearance without defect	
3	High Temp. & High Humi. Storage	60°C 90%RH	120Hrs		Appearance without defect	
4	High Temp. Operating Display	70°C	120Hrs		Appearance without defect	
5	Low Temp. Operating Display	-20°C	120Hrs		Appearance without defect	
6	Thermal Shock	-20°C, 30min → 70°C, 30min  (1cycle)			Appearance without defect	10 cycles

Inspection Provision

1. Purpose

The NAN YA inspection provision provides outgoing inspection provision and its expected quality level based on our outgoing inspection of NAN YA LCD produces.

2. Applicable Scope

The NAN YA inspection provision is applicable to the arrangement in regard to outgoing inspection and quality assurance after outgoing.

3. Technical Terms

3-1 NAN YA Technical Terms

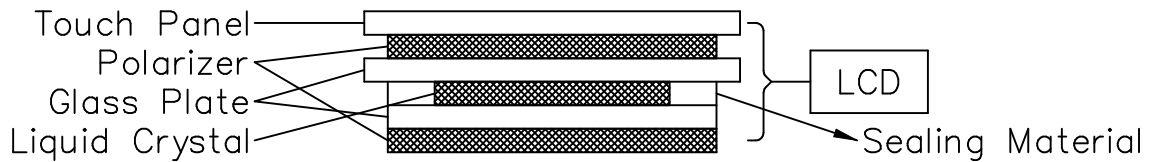

4. Outgoing Inspection

4-1 Inspection Method

MIL-STD-105E Level II Regular inspection

4-2 Inspection Standard

	Item		AQL(%)	Remarks
Major Defect	Dots	Opens Shorts Erroneous operation	0.4	faults which substantially lower the practicality and the initial purpose difficult to achieve.
	Solder appearance	Shorts Loose		
	Cracks	Display surface cracks		
	Touch Panel contact resistance			
	Touch Panel input load			

	Touch Panel linearity		0.4	
	Dimensions	External from Dimensions	0.4	
Minor Defect	Inside the glass	Black spots	0.65	faults which appear to pose almost no obstacle to the practicality, effective use, and operation.
	Polarizing plate	Scratches, foreign Matter, air bubbles, and peeling		
	Dots	Pinhole, deformation		
	Color tone	Color unevenness		
	Solder appearance	Cold solder Solder projections		

4-3 Inspection Provisions
*Viewing Area Definition

Fig. 1

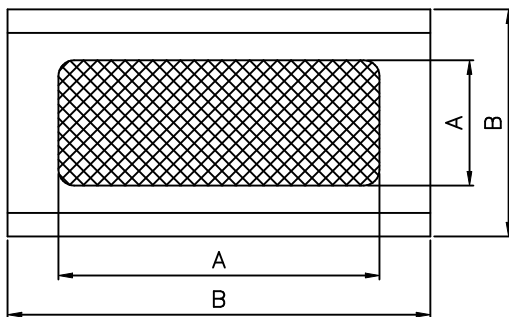

A : Zone Viewing Area
B : Zone Glass Plate Outline

*Inspection place to be 500 to 1000 lux illuminance uniformly without glaring.
The distance between luminous source(daylight fluorescent lamp and cool white fluorescent lamp) and sample to be 30cm to 50cm.

*Test and measurement are performed under the following conditions, unless otherwise specified.

Temperature 20± 15°C
Humidity 65± 20%R.H.
Pressure 860~1060hPa(mmbar)

In case of doubtful judgment, it is performed under the following conditions.

Temperature 20± 2°C
Humidity 65± 5%R.H.
Pressure 860~1060hPa(mmbar)

5.Specification for quality check
5-1 Electrical characteristics

NO.	Item	Criterion
1	Non operational	Fail
2	Miss operating	Fail
3	Missing dot	Fail
4	Contrast irregular	Fail
5	Response time	Within Specified value
6	Touch Panel contact resistance	Within Specified value
7	Touch Panel input load	Within Specified value
8	Touch Panel linearity	Within Specified value
9	Backlight turn on/off	Within Specified value

5-2 External Appearance Defect

NO.	Item	Criterion																							
1	Black spots, foreign matter, and white spots (Including light leakage due to pinholes of polarizing plates, etc.)	<p>(1)-1-Spots</p> <table border="1" data-bbox="703 490 1398 819"> <thead> <tr> <th>Average Diameter(mm):D</th> <th>Number of pieces permitted</th> <th>Minimum Space</th> </tr> </thead> <tbody> <tr> <td>$D \leq 0.2$</td> <td>Ignore</td> <td>-</td> </tr> <tr> <td>$0.2 < D \leq 0.3$</td> <td>5</td> <td>10mm</td> </tr> <tr> <td>$0.3 < D \leq 0.4$</td> <td>2</td> <td>30mm</td> </tr> <tr> <td>$0.4 < D$</td> <td>0</td> <td></td> </tr> </tbody> </table> <p>Number of total pieces is set to within 5 pieces.</p> <p>Note that when there are 2 pieces or more, they are not to be concentrated. Set as: Average diameter = (Long diameter + Short diameter)/2</p> <p>(1)-2-Blurred Spots(At lighting condition)</p> <table border="1" data-bbox="703 1234 1334 1464"> <thead> <tr> <th>Average Diameter(mm):D</th> <th>Number of pieces permitted</th> </tr> </thead> <tbody> <tr> <td>$D \leq 0.3$</td> <td>Ignore</td> </tr> <tr> <td>$0.3 < D \leq 0.75$</td> <td>5</td> </tr> <tr> <td>$0.75 < D$</td> <td>0</td> </tr> </tbody> </table> <p>Number of total pieces is set to within 5 pieces.</p> <p>Note that when there are 2 pieces or more, they are not to be concentrated. Set as: Average diameter = (Long diameter + Short diameter)/2</p>	Average Diameter(mm):D	Number of pieces permitted	Minimum Space	$D \leq 0.2$	Ignore	-	$0.2 < D \leq 0.3$	5	10mm	$0.3 < D \leq 0.4$	2	30mm	$0.4 < D$	0		Average Diameter(mm):D	Number of pieces permitted	$D \leq 0.3$	Ignore	$0.3 < D \leq 0.75$	5	$0.75 < D$	0
Average Diameter(mm):D	Number of pieces permitted	Minimum Space																							
$D \leq 0.2$	Ignore	-																							
$0.2 < D \leq 0.3$	5	10mm																							
$0.3 < D \leq 0.4$	2	30mm																							
$0.4 < D$	0																								
Average Diameter(mm):D	Number of pieces permitted																								
$D \leq 0.3$	Ignore																								
$0.3 < D \leq 0.75$	5																								
$0.75 < D$	0																								

1	Line	<p>(1)-1-Lines</p> <table border="1" data-bbox="703 443 1431 721"> <thead> <tr> <th>Width(mm): W</th> <th>Length(mm): L</th> <th>Number of pieces permitted</th> </tr> </thead> <tbody> <tr> <td>$W \leq 0.03$</td> <td>Ignore</td> <td>Ignore</td> </tr> <tr> <td>$0.03 < W \leq 0.08$</td> <td>$L \leq 4$</td> <td>2</td> </tr> <tr> <td>$0.08 < W \leq 0.1$</td> <td>$L \leq 1$</td> <td>1</td> </tr> </tbody> </table> <p>Object exceeding 0.1mm follow the standards of the spots form. Note that when there are 2 pieces or more, they are not to be concentrated.</p> <p>(1)-2-Blurred Lines(At lighting condition)</p> <table border="1" data-bbox="703 1021 1431 1299"> <thead> <tr> <th>Width(mm): W</th> <th>Length(mm): L</th> <th>Number of pieces permitted</th> </tr> </thead> <tbody> <tr> <td>$W \leq 0.03$</td> <td>Ignore</td> <td>Ignore</td> </tr> <tr> <td>$0.03 < W \leq 0.08$</td> <td>$L \leq 3$</td> <td>6</td> </tr> <tr> <td>$0.08 < W$</td> <td>$3 < L$</td> <td>None</td> </tr> </tbody> </table> <p>Object exceeding 0.1mm follow the standards of the spots form. Note that when there are 2 pieces or more, they are not to be concentrated.</p>	Width(mm): W	Length(mm): L	Number of pieces permitted	$W \leq 0.03$	Ignore	Ignore	$0.03 < W \leq 0.08$	$L \leq 4$	2	$0.08 < W \leq 0.1$	$L \leq 1$	1	Width(mm): W	Length(mm): L	Number of pieces permitted	$W \leq 0.03$	Ignore	Ignore	$0.03 < W \leq 0.08$	$L \leq 3$	6	$0.08 < W$	$3 < L$	None
Width(mm): W	Length(mm): L	Number of pieces permitted																								
$W \leq 0.03$	Ignore	Ignore																								
$0.03 < W \leq 0.08$	$L \leq 4$	2																								
$0.08 < W \leq 0.1$	$L \leq 1$	1																								
Width(mm): W	Length(mm): L	Number of pieces permitted																								
$W \leq 0.03$	Ignore	Ignore																								
$0.03 < W \leq 0.08$	$L \leq 3$	6																								
$0.08 < W$	$3 < L$	None																								
2	Scratches(Glass, reflection plates, and polarizing plates)	In accordance with black spots. (At non lighting condition)																								
3	Color irregular	Not remarkable color irregular.																								

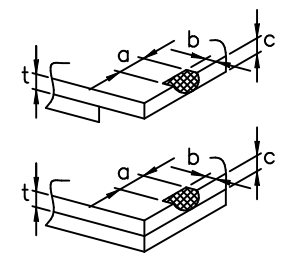
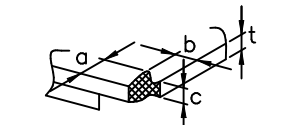
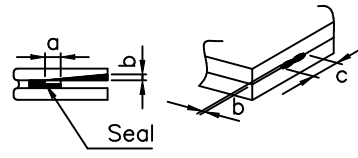
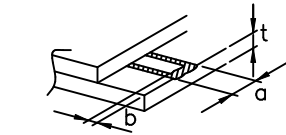
4	Air bubbles polarizing plates, and reflection plates	<table border="1" data-bbox="702 392 1209 678"> <tr> <td data-bbox="702 392 954 533">Average Diameter (mm): D</td> <td data-bbox="954 392 1209 533">Number of pieces permitted</td> <td data-bbox="1209 392 1450 678" rowspan="2">Average diameter = (Long diameter + Short diameter)/2</td> </tr> <tr> <td data-bbox="702 533 954 678">D ≤ 0.3 0.3 < D</td> <td data-bbox="954 533 1209 678">Ignore 0</td> </tr> </table> <p data-bbox="702 694 1450 772">Note that when there are 4 pieces or more, they are not to be concentrated.</p>		Average Diameter (mm): D	Number of pieces permitted	Average diameter = (Long diameter + Short diameter)/2	D ≤ 0.3 0.3 < D	Ignore 0
Average Diameter (mm): D	Number of pieces permitted	Average diameter = (Long diameter + Short diameter)/2						
D ≤ 0.3 0.3 < D	Ignore 0							
5	Cracks	<p data-bbox="654 784 1050 828">(1) General crack</p> 	<p data-bbox="1050 784 1450 817">$a \leq 5$</p> <p data-bbox="1050 828 1450 862">$b \leq 2$</p> <p data-bbox="1050 873 1450 907">$c \leq t$</p> <p data-bbox="1050 918 1450 1167">Where, a and b are ignored when less than or equal to 0.5 The numbers of pieces are set at up to 5 pieces.</p>					
		<p data-bbox="654 1167 1050 1209">(2) Corner crack</p> 	<p data-bbox="1050 1167 1450 1198">$a \leq 2.5$</p> <p data-bbox="1050 1209 1450 1243">$b \leq 2.5$</p> <p data-bbox="1050 1254 1450 1288">$c \leq t$</p> <p data-bbox="1050 1299 1450 1332">$a + b \leq 4$</p>					
		<p data-bbox="654 1355 1050 1400">(3) Seal portion crack</p> 	<p data-bbox="1050 1355 1450 1388">$a \leq$ The seal width $\times 1/3$</p> <p data-bbox="1050 1400 1450 1433">$b \leq t \times 2/3$</p> <p data-bbox="1050 1444 1450 1478">$c \leq 5$</p> <p data-bbox="1050 1489 1450 1624">The numbers of pieces are set at up to 5 pieces.</p>					
		<p data-bbox="654 1624 1050 1668">(4) ITO Pin crack</p> 	<p data-bbox="1050 1624 1450 1657">$a \leq 5$</p> <p data-bbox="1050 1668 1450 1702">$b \leq 1/3$ pin length</p> <p data-bbox="1050 1713 1450 1747">$c \leq t$</p>					
		<p data-bbox="654 1854 1050 1899">(5) Progressive cracks</p>	<p data-bbox="1050 1854 1450 1946">All taken to be unacceptable.</p>					

6	Outer dimensions	Should be within the tolerance.
7	Newton ring(touch panel)	Orbicular of interference fringes is not allowed in the optimum contrast within the active area under viewing angle.
8	Soldering	Should be no defective soldering such as shorting, loose terminal cold solder, peeling of printed circuit board pattern, improper mounting position, etc.

5-3 Dot Appearance Defect

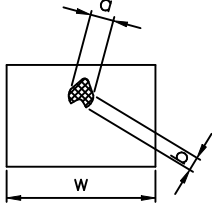
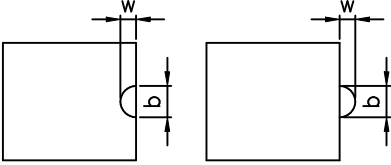
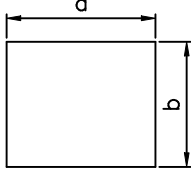
NO.	Item	Criteria
1	Pinhole	 <p>Dot display a and b are each $\leq 0.2\text{mm}$ The overall total is taken be with in 10 units. Note that they are not to be concentrated.</p>
2	Missing	 <p>Dot display a and b are each $\leq 0.2\text{mm}$ The overall total is taken to be with in 10 units.</p>
3	Thick and thin display	 <p>Taken to be within $\pm 1.5\%$ of display character width(a) and height(b).</p>

NOTICE:

- SAFETY

- 1.If the LCD panel breaks, be careful not to get the liquid crystal to touch your skin.
- 2.If the liquid crystal touches your skin or clothes, please wash it off immediately by using soap and water.

- HANDLING

- 1.Avoid static electricity which can damage the CMOS LSI.
- 2.Do not remove the panel or frame from the module.
- 3.The polarizing plate of the display is very fragile. So, please handle it very carefully.
- 4.Do not wipe the polarizing plate with a dry cloth, as it may easily scratch the surface of plate.
- 5.Do not use ketonics solvent & Aromatic solvent. Use a soft cloth soaked with a cleaning naphtha solvent.

- STORAGE

- 1.Store the panel or module in a dark place where the temperature is $25^{\circ}\text{C}\pm 5^{\circ}\text{C}$ and the humidity is below 65% RH.
- 2.Do not place the module near organics solvents or corrosive gases.
- 3.Do not crush, shake, or jolt the module.

- TERMS OF WARRANT

- 1.Acceptance inspection period
The period is within one month after the arrival of contracted commodity at the buyer's factory site.
- 2.Applicable warrant period
The period is within twelve months since the date of shipping out under normal using and storage conditions.

Pin No.	Symbol	Signal Level	Function
1	DOWN	-	Down Direction
2	LEFT	-	Left Direction
3	UP	-	Up Direction
4	RIGHT	-	Right Direction

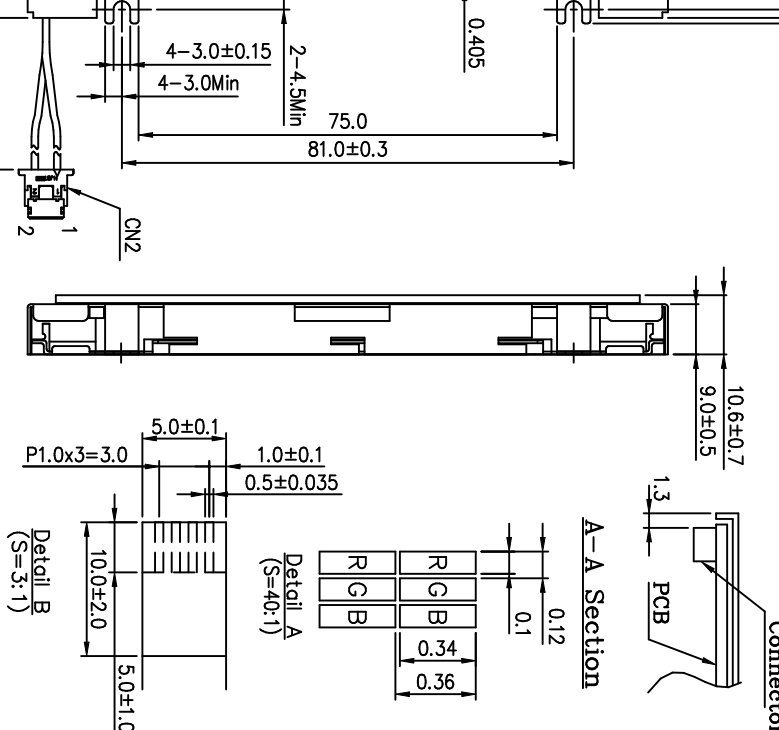
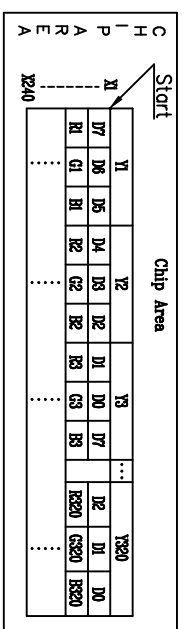
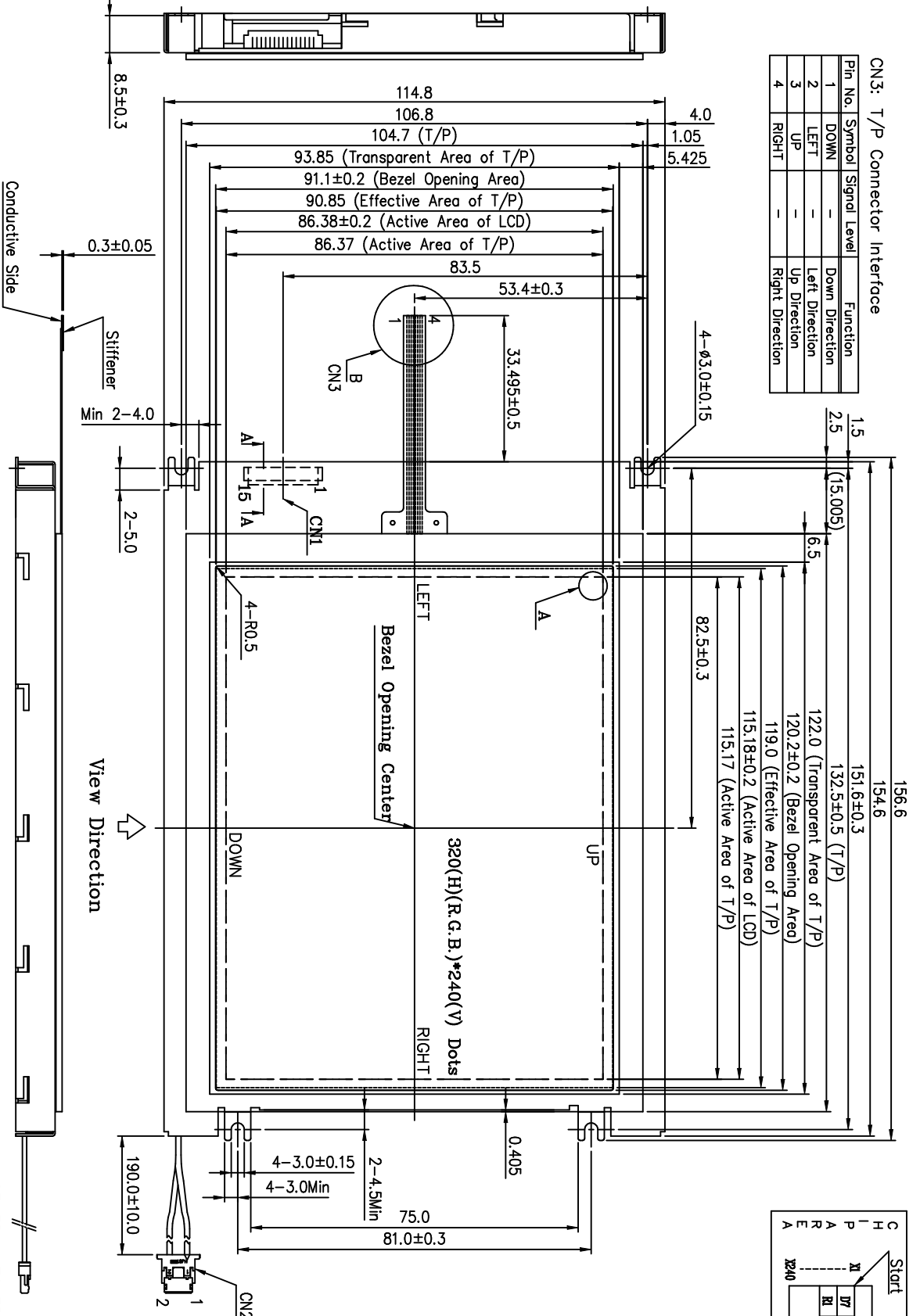

- Notes:
1. Resolution : 320(H)(R.G.B) x 240(V) Dots
 2. Backlight : LED
 3. Frame Material : SECC (t=0.5)
 4. Touch Panel : Anti-Glare (t=1.4)

GENERAL TOLERANCE LIST

DIMENSION	TOLERANCE
L ≤ 6	±0.25 (mm)
6 < L ≤ 18	±0.3 (mm)
18 < L ≤ 50	±0.4 (mm)
50 < L ≤ 125	±0.5 (mm)
125 < L	±0.6 (mm)
ANGLE	±1° (DEG)

Pin No.	Symbol	Function	Level	10	D5
1	FRM	Synchronous signal for driving scanning line	H	11	D4
2	LOAD	Data signal latch clock	H → L	12	D3
3	CP	Data signal shift clock	H → L	13	D2
4	DISP	Display control signal	H(ON),L(OFF)	14	D1
5	VDD	Power supply for logic	-	15	D0
6	VSS	GND	-	CN2 : BHR-Q2VS-1 (JST)	
7	VEE	Power supply for LCD	-		
8	D7	Display data	H(ON),L(OFF)		
9	D6	Display data	H(ON),L(OFF)		

Pin No.	Symbol	Function	Level	10	D5
10	D5	Display data	H(ON),L(OFF)	11	D4
11	D4			12	D3
12	D3			13	D2
13	D2			14	D1
14	D1	CN2 : BHR-Q2VS-1 (JST)		15	D0
15	D0	Power supply for LED Backlight (+)	-	1	A
16	A	Power supply for LED Backlight (-)	-	2	K

REV. NO.	DESCRIPTION	DATE	DESIGN	CHECK	APPROVE	DWG NO.
1						MB61AD77A

南亞塑膠工業股份有限公司
NAN YA PLASTICS CORPORATION
製品圖
LCCFTBTB61M7YS
NAME DATE THIRD ANGLE P.
APPROVE
CHECK
DESIGN Compos Chen 95.09.06 SCALE UNIT
DRAWN Compos Chen 95.09.06 1/1 mm

THE NOTES OF LCM USING

LCM is easy to damage.

Please follow the notes as bellows, and be careful of handling!

Correct handling

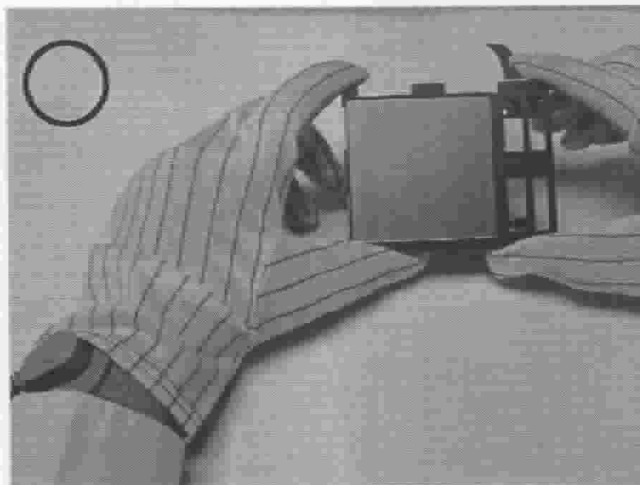
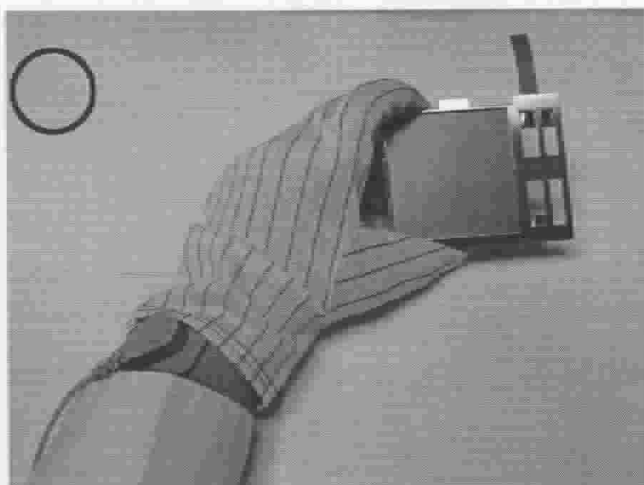

As above picture, please handle with glove by LCM edges and full EOS/ESD protection.

Incorrect handling

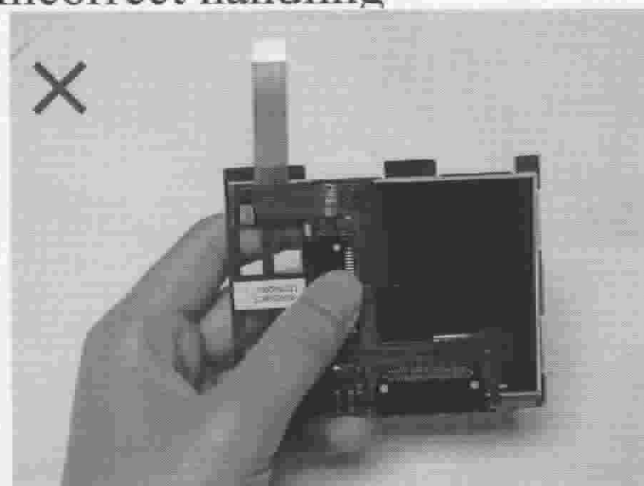

Please don't touch IC directly.

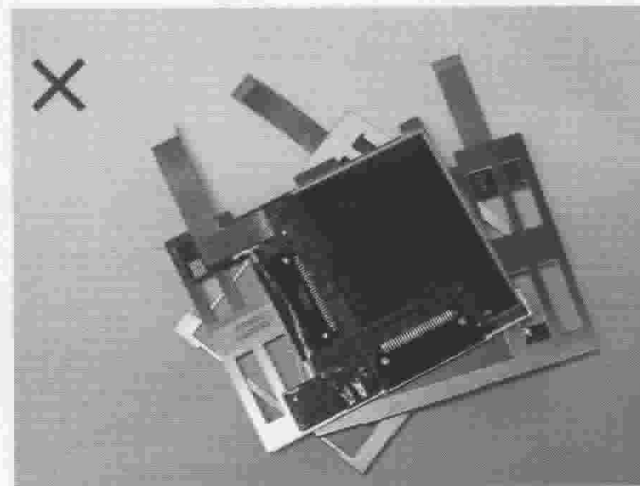

Please don't put one on another LCM.

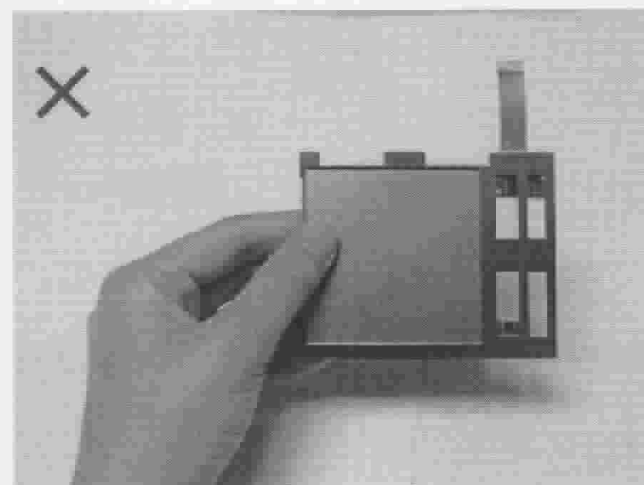

Please don't hold the surface of LCM.

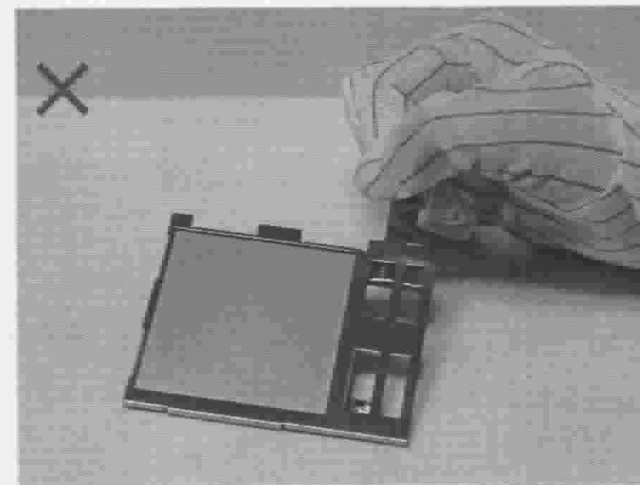

Please don't stretch interface of output.

THE NOTES OF LCD USING

LCD is easy damage.

Please follow notes as bellows, and be careful of handling!

Correct handling

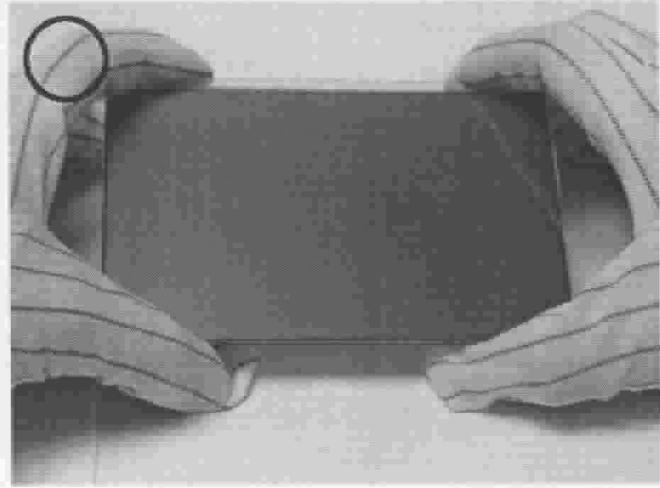
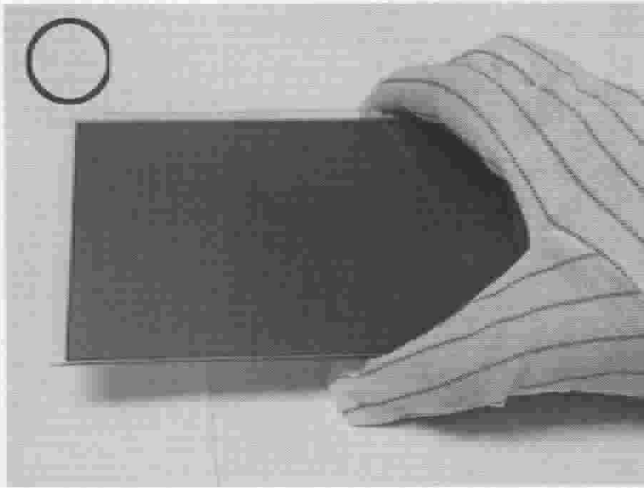

As above picture, please handle with glove by LCD edges and full EOS/ESD protection.

Incorrect handling

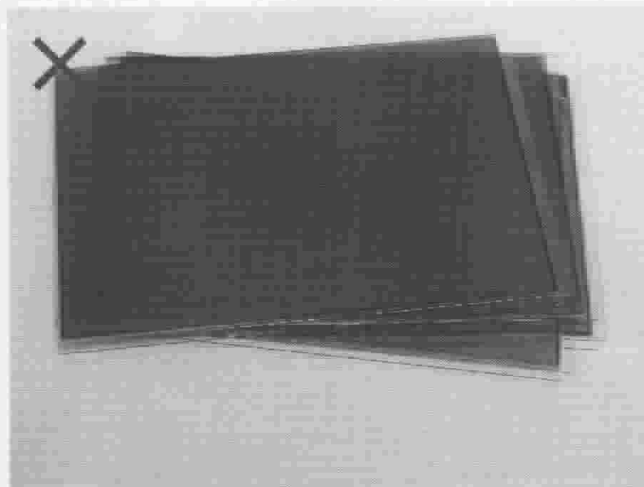

Please don't put one on another LCD.

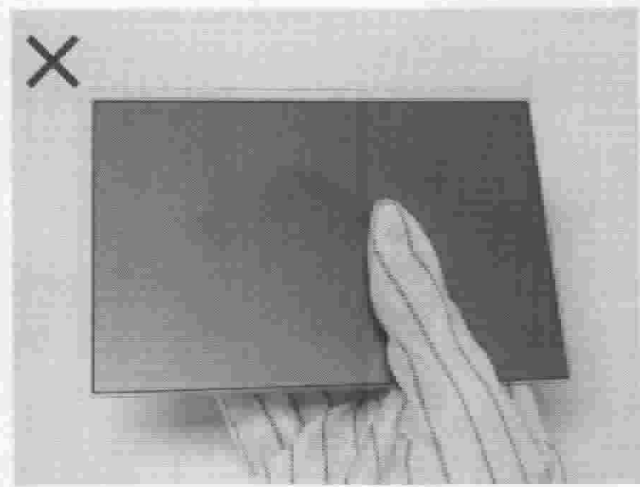

Please don't hold the surface of LCD.

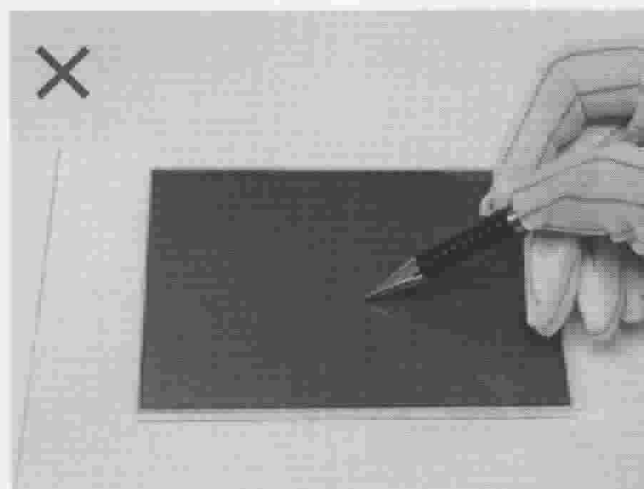

Please don't operate with sharp stick such as sharp pencil.

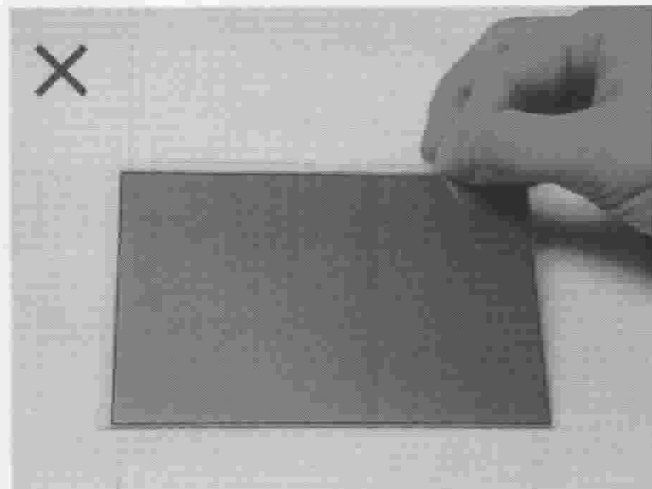

Please don't touch ITO glass without anti-static gloves.

