

## FEATURES

**Voltage feedback architecture**

**Rail-to-rail output swing: 0.1 V to 4.9 V**

**High speed amplifiers**

410 MHz, -3 dB bandwidth,  $G = 1$

210 MHz, -3 dB bandwidth,  $G = 2$

Slew rate: 870 V/ $\mu$ s

53 MHz, 0.1 dB large signal flatness

5.3 ns settling time to 0.1% with 2 V step

**High input common-mode voltage range**

$-V_S - 0.2$  V to  $+V_S - 1$  V

**Supply range: 3 V to 5.5 V**

**Differential gain error: 0.01%**

**Differential phase error: 0.01°**

**Low power**

7.8 mA/amplifier typical supply current

**Power-down feature**

**Available in 16-lead LFCSP**

## APPLICATIONS

Professional video

Consumer video

Imaging

Instrumentation

Base stations

Active filters

## GENERAL DESCRIPTION

The ADA4855-3 (triple) is a single-supply, rail-to-rail output operational amplifier. It provides excellent high speed performance with 410 MHz, -3 dB bandwidth and a slew rate of 870 V/ $\mu$ s. It has a wide input common-mode voltage range that extends from 0.2 V below ground to 1 V below the positive rail. In addition, the output voltage swings within 100 mV of either supply rail, making this rail-to-rail operational amplifier easy to use on single-supply voltages as low as 3.3 V.

The ADA4855-3 offers a typical low power of 7.8 mA per amplifier and is capable of delivering up to 57 mA of load current. It also features a power-down function for power sensitive applications that reduces the supply current down to 1 mA.

The ADA4855-3 is available in a 16-lead LFCSP and is designed to work over the extended industrial temperature range of  $-40^{\circ}\text{C}$  to  $+105^{\circ}\text{C}$ .

## CONNECTION DIAGRAM

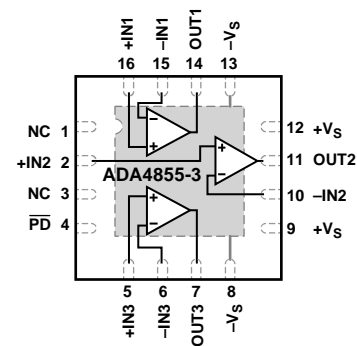

NOTES  
1. NC = NO CONNECT.  
2. EXPOSED PAD CONNECTED TO  $-V_S$ .

07885-001

Figure 1.

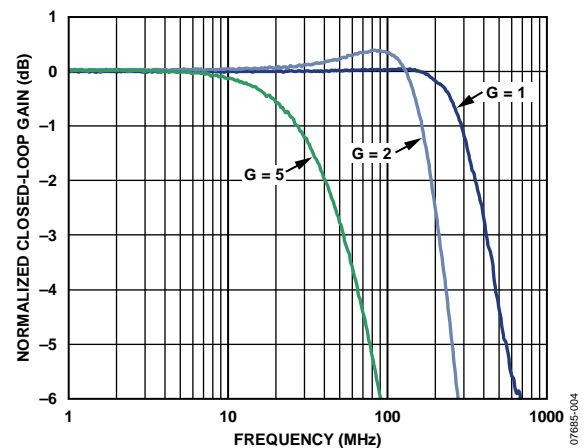

Figure 2. Frequency Response

Rev. A

[Document Feedback](#)

Information furnished by Analog Devices is believed to be accurate and reliable. However, no responsibility is assumed by Analog Devices for its use, nor for any infringements of patents or other rights of third parties that may result from its use. Specifications subject to change without notice. No license is granted by implication or otherwise under any patent or patent rights of Analog Devices. Trademarks and registered trademarks are the property of their respective owners.

# ADA4855-3\* PRODUCT PAGE QUICK LINKS

Last Content Update: 02/23/2017

---

## COMPARABLE PARTS

View a parametric search of comparable parts.

## EVALUATION KITS

- ADA4855-3 Evaluation Board

## DOCUMENTATION

### Application Notes

- AN-402: Replacing Output Clamping Op Amps with Input Clamping Amps
- AN-417: Fast Rail-to-Rail Operational Amplifiers Ease Design Constraints in Low Voltage High Speed Systems
- AN-581: Biasing and Decoupling Op Amps in Single Supply Applications

### Data Sheet

- ADA4855-3: Single Supply, High Speed, Rail-to-Rail Output, Triple Op Amp Data Sheet

### User Guides

- UG-115: Universal Evaluation Board for Triple, High Speed Op Amps Offered in 16-Lead, 4 mm × 4 mm LFCSP Packages

## TOOLS AND SIMULATIONS

- Analog Filter Wizard
- Analog Photodiode Wizard
- Power Dissipation vs Die Temp
- VRMS/dBm/dBu/dBV calculators
- ADA4855 SPICE Macro Model

## REFERENCE MATERIALS

### Tutorials

- MT-032: Ideal Voltage Feedback (VFB) Op Amp
- MT-033: Voltage Feedback Op Amp Gain and Bandwidth
- MT-047: Op Amp Noise
- MT-048: Op Amp Noise Relationships: 1/f Noise, RMS Noise, and Equivalent Noise Bandwidth
- MT-049: Op Amp Total Output Noise Calculations for Single-Pole System
- MT-050: Op Amp Total Output Noise Calculations for Second-Order System
- MT-052: Op Amp Noise Figure: Don't Be Misled
- MT-053: Op Amp Distortion: HD, THD, THD + N, IMD, SFDR, MTPR
- MT-056: High Speed Voltage Feedback Op Amps
- MT-058: Effects of Feedback Capacitance on VFB and CFB Op Amps
- MT-059: Compensating for the Effects of Input Capacitance on VFB and CFB Op Amps Used in Current-to-Voltage Converters
- MT-060: Choosing Between Voltage Feedback and Current Feedback Op Amps

## DESIGN RESOURCES

- ADA4855-3 Material Declaration
- PCN-PDN Information
- Quality And Reliability
- Symbols and Footprints

## DISCUSSIONS

View all ADA4855-3 EngineerZone Discussions.

## SAMPLE AND BUY

Visit the product page to see pricing options.

## TECHNICAL SUPPORT

Submit a technical question or find your regional support number.

## DOCUMENT FEEDBACK

Submit feedback for this data sheet.

**TABLE OF CONTENTS**

Features .....	1	Theory of Operation .....	14
Applications.....	1	Applications Information .....	15
Connection Diagram .....	1	Gain Configurations .....	15
General Description .....	1	20 MHz Active Low-Pass Filter .....	15
Revision History .....	2	RGB Video Driver .....	16
Specifications.....	3	Driving Multiple Video Loads.....	16
5 V Operation .....	3	$\overline{\text{PD}}$ (Power-Down) Pin .....	16
3.3 V Operation .....	4	Single-Supply Operation .....	17
Absolute Maximum Ratings.....	5	Power Supply Bypassing .....	17
Thermal Resistance .....	5	Layout .....	17
Maximum Power Dissipation .....	5	Outline Dimensions .....	18
ESD Caution.....	5	Ordering Guide .....	18
Pin Configuration and Function Descriptions.....	6		
Typical Performance Characteristics .....	7		
Test Circuits.....	13		

**REVISION HISTORY**

**2/13—Rev. 0 to Rev. A**

Change CP-16-4 Package to CP-26-23, Figure 1 .....	1
Change CP-16-4 Package to CP-26-23, Figure 4.....	6
Updated Outline Dimensions .....	18
Changes to Ordering Guide .....	18

**11/08—Revision 0: Initial Version**

## SPECIFICATIONS

### 5 V OPERATION

$T_A = 25^\circ\text{C}$ ,  $V_S = 5\text{ V}$ ,  $G = 1$ ,  $R_L = 150\ \Omega$ , unless otherwise noted.

Table 1.

Parameter	Test Conditions	Min	Typ	Max	Unit
<b>DYNAMIC PERFORMANCE</b>					
-3 dB Bandwidth	$V_O = 0.1\text{ V p-p}$		410		MHz
	$V_O = 2\text{ V p-p}$		200		MHz
	$V_O = 0.1\text{ V p-p}$ , $G = 2$		210		MHz
	$V_O = 2\text{ V p-p}$ , $G = 2$		120		MHz
	Bandwidth for 0.1 dB Flatness	$V_O = 2\text{ V p-p}$		53	
	$V_O = 2\text{ V p-p}$ , $G = 2$		50		MHz
Slew Rate	$V_O = 2\text{ V step}$		870		V/ $\mu\text{s}$
Settling Time to 0.1%	$V_O = 2\text{ V step (rise/fall)}$		5.3/9.5		ns
	$V_O = 2\text{ V step (rise/fall)}$ , $G = 2$		7.4/7		ns
<b>NOISE/DISTORTION PERFORMANCE</b>					
Harmonic Distortion (HD2/HD3)	$f_C = 5\text{ MHz}$ , $V_O = 2\text{ V p-p}$ , $R_L = 1\text{ k}\Omega$		-84/-105		dBc
	$f_C = 20\text{ MHz}$ , $V_O = 2\text{ V p-p}$ , $R_L = 1\text{ k}\Omega$		-60/-66		dBc
Crosstalk, Output to Output	$f = 5\text{ MHz}$ , $G = 2$		-90		dBc
Input Voltage Noise	$f = 100\text{ kHz}$		6.8		nV/ $\sqrt{\text{Hz}}$
Input Current Noise	$f = 100\text{ kHz}$		2		pA/ $\sqrt{\text{Hz}}$
Differential Gain Error	$G = 2$		0.01		%
Differential Phase Error	$G = 2$		0.01		Degrees
<b>DC PERFORMANCE</b>					
Input Offset Voltage			1.3	3	mV
Input Offset Voltage Drift			5.5		$\mu\text{V}/^\circ\text{C}$
Input Bias Current			-3.8		$\mu\text{A}$
Input Offset Current			$\pm 0.05$		$\mu\text{A}$
Open-Loop Gain	$V_O = 0.5\text{ V to }4.5\text{ V}$		92		dB
<b>INPUT CHARACTERISTICS</b>					
Input Resistance			6.4		M $\Omega$
Input Capacitance			0.5		pF
Input Common-Mode Voltage Range		$-V_S - 0.2$		$+V_S - 1$	V
Common-Mode Rejection Ratio	$V_{CM} = -0.2\text{ V to }+4\text{ V}$		94		dB
<b>OUTPUT CHARACTERISTICS</b>					
Output Voltage Swing			0.1 to 4.9		V
Linear Output Current per Amplifier	$\text{HD2} \leq -60\text{ dBc}$ , $R_L = 10\ \Omega$		57		mA
<b>POWER-DOWN</b>					
Turn-On Time			78		ns
Turn-Off Time			1.2		$\mu\text{s}$
Bias Current	On		0.3		$\mu\text{A}$
	Off		-125		$\mu\text{A}$
Turn-On Voltage			$+V_S - 1.25$		V
<b>POWER SUPPLY</b>					
Operating Range		3		5.5	V
Quiescent Current per Amplifier			7.8		mA
Supply Current When Powered Down			1.1		mA
Power Supply Rejection Ratio	$\Delta V_S = 4.5\text{ V to }5.5\text{ V}$		96		dB

**3.3 V OPERATION**

$T_A = 25^\circ\text{C}$ ,  $V_S = 3.3\text{ V}$ ,  $G = 1$ ,  $R_L = 150\ \Omega$ , unless otherwise noted.

**Table 2.**

Parameter	Test Conditions	Min	Typ	Max	Unit
<b>DYNAMIC PERFORMANCE</b>					
-3 dB Bandwidth	$V_O = 0.1\text{ V p-p}$		430		MHz
	$V_O = 1.4\text{ V p-p}$		210		MHz
	$V_O = 0.1\text{ V p-p}$ , $G = 2$		210		MHz
	$V_O = 2\text{ V p-p}$ , $G = 2$		125		MHz
	Bandwidth for 0.1 dB Flatness	$V_O = 1.4\text{ V p-p}$ , $G = 2$		55	
Slew Rate	$V_O = 2\text{ V step}$ , $G = 2$		870		V/ $\mu\text{s}$
Settling Time to 0.1%	$V_O = 2\text{ V step (rise/fall)}$ , $G = 2$		7.4/7.1		ns
<b>NOISE/DISTORTION PERFORMANCE</b>					
Harmonic Distortion (HD2/HD3)	$f_C = 5\text{ MHz}$ , $V_O = 2\text{ V p-p}$ , $R_L = 1\text{ k}\Omega$		-76/-76		dBc
	$f_C = 20\text{ MHz}$ , $V_O = 2\text{ V p-p}$ , $R_L = 1\text{ k}\Omega$		-68/-75		dBc
Crosstalk, Output to Output	$f = 5\text{ MHz}$ , $G = 2$		-88		dBc
Input Voltage Noise	$f = 100\text{ kHz}$		6.8		nV/ $\sqrt{\text{Hz}}$
Input Current Noise	$f = 100\text{ kHz}$		2		pA/ $\sqrt{\text{Hz}}$
Differential Gain Error	$G = 2$		0.01		%
Differential Phase Error	$G = 2$		0.01		Degrees
<b>DC PERFORMANCE</b>					
Input Offset Voltage			1.3		mV
Input Offset Voltage Drift			5.5		$\mu\text{V}/^\circ\text{C}$
Input Bias Current			-3.8		$\mu\text{A}$
Input Offset Current			0.05		$\mu\text{A}$
Open-Loop Gain	$V_O = 0.5\text{ V to }4.5\text{ V}$		92		dB
<b>INPUT CHARACTERISTICS</b>					
Input Resistance			6.4		M $\Omega$
Input Capacitance			0.5		pF
Input Common-Mode Voltage Range		$-V_S - 0.2$		$+V_S - 1$	V
Common-Mode Rejection Ratio	$V_{CM} = -0.2\text{ V to }+3.2\text{ V}$		94		dB
<b>OUTPUT CHARACTERISTICS</b>					
Output Voltage Swing			0.1 to 3.22		V
Linear Output Current per Amplifier	$\text{HD2} \leq -60\text{ dBc}$ , $R_L = 10\ \Omega$		40		mA
<b>POWER-DOWN</b>					
Turn-On Time			78		ns
Turn-Off Time			1.2		$\mu\text{s}$
Turn-On Voltage			$+V_S - 1.25$		V
<b>POWER SUPPLY</b>					
Operating Range		3		5.5	V
Quiescent Current per Amplifier			7.5		mA
Supply Current When Powered Down			0.95		mA
Power Supply Rejection Ratio	$\Delta V_S = 2.97\text{ V to }3.63\text{ V}$		94		dB

## ABSOLUTE MAXIMUM RATINGS

Table 3.

Parameter	Rating
Supply Voltage	6 V
Internal Power Dissipation <sup>1</sup>	See Figure 3
Common-Mode Input Voltage	( $-V_S - 0.2$ V) to ( $+V_S - 1$ V)
Differential Input Voltage	$\pm V_S$
Output Short-Circuit Duration	Observe power curves
Storage Temperature Range	$-65^{\circ}\text{C}$ to $+125^{\circ}\text{C}$
Operating Temperature Range	$-40^{\circ}\text{C}$ to $+105^{\circ}\text{C}$
Lead Temperature (Soldering, 10 sec)	$300^{\circ}\text{C}$

<sup>1</sup> Specification is for device in free air.

Stresses above those listed under Absolute Maximum Ratings may cause permanent damage to the device. This is a stress rating only; functional operation of the device at these or any other conditions above those indicated in the operational section of this specification is not implied. Exposure to absolute maximum rating conditions for extended periods may affect device reliability.

### THERMAL RESISTANCE

$\theta_{JA}$  is specified for the worst-case conditions, that is,  $\theta_{JA}$  is specified for a device soldered in a circuit board for surface-mount packages.

Table 4.

Package Type	$\theta_{JA}$	$\theta_{JC}$	Unit
16-Lead LFCSP	67	17.5	$^{\circ}\text{C}/\text{W}$

### MAXIMUM POWER DISSIPATION

The maximum power that can be safely dissipated by the ADA4855-3 is limited by the associated rise in junction temperature. The maximum safe junction temperature for plastic encapsulated devices is determined by the glass transition temperature of the plastic, approximately  $150^{\circ}\text{C}$ . Temporarily exceeding this limit may cause a shift in parametric performance due to a change in the stresses exerted on the die by the package. Exceeding a junction temperature of  $175^{\circ}\text{C}$  for an extended period can result in device failure.

To ensure proper operation, it is necessary to observe the maximum power derating curves.

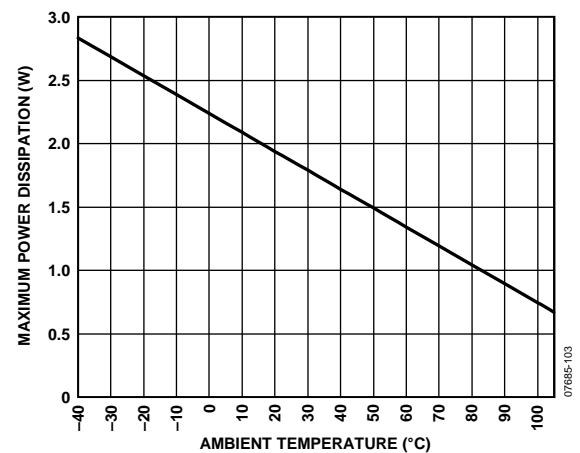

Figure 3. Maximum Power Dissipation vs. Ambient Temperature

### ESD CAUTION



**ESD (electrostatic discharge) sensitive device.** Charged devices and circuit boards can discharge without detection. Although this product features patented or proprietary protection circuitry, damage may occur on devices subjected to high energy ESD. Therefore, proper ESD precautions should be taken to avoid performance degradation or loss of functionality.

## PIN CONFIGURATION AND FUNCTION DESCRIPTIONS

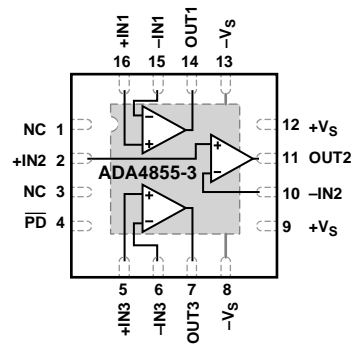

NOTES  
 1. NC = NO CONNECT.  
 2. EXPOSED PAD CONNECTED TO  $-V_S$ .

07885-003

Figure 4. Pin Configuration

Table 5. Pin Function Descriptions

Pin No.	Mnemonic	Description
1	NC	No Connect.
2	+IN2	Noninverting Input 2.
3	NC	No Connect.
4	$\overline{\text{PD}}$	Power Down.
5	+IN3	Noninverting Input 3.
6	-IN3	Inverting Input 3.
7	OUT3	Output 3.
8	$-V_S$	Negative Supply.
9	$+V_S$	Positive Supply.
10	-IN2	Inverting Input 2.
11	OUT2	Output 2.
12	$+V_S$	Positive Supply.
13	$-V_S$	Negative Supply.
14	OUT1	Output 1.
15	-IN1	Inverting Input 1.
16	+IN1	Noninverting Input 1.
17 (EPAD)	Exposed Pad (EPAD)	The exposed pad must be connected to $-V_S$ .

# TYPICAL PERFORMANCE CHARACTERISTICS

T = 25°C, V<sub>S</sub> = 5V, G = 1, R<sub>F</sub> = 1 kΩ for G > 1, R<sub>L</sub> = 150 Ω, small signal V<sub>OUT</sub> = 100 mV p-p, and large signal V<sub>OUT</sub> = 2 V p-p, unless otherwise noted.

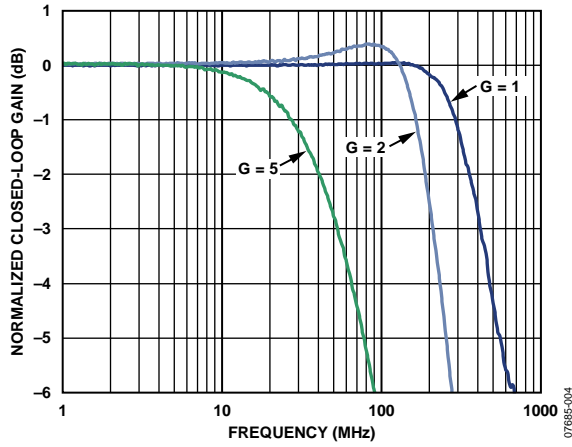

Figure 5. Small Signal Frequency Response vs. Gain

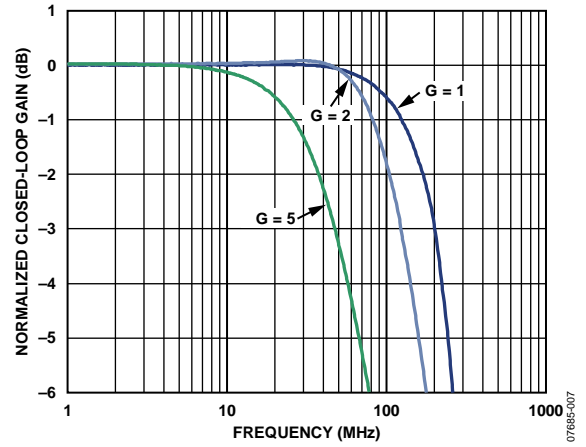

Figure 8. Large Signal Frequency Response vs. Gain

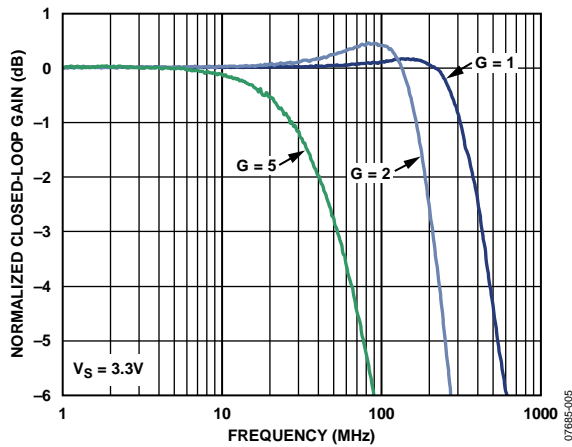

Figure 6. Small Signal Frequency Response vs. Gain

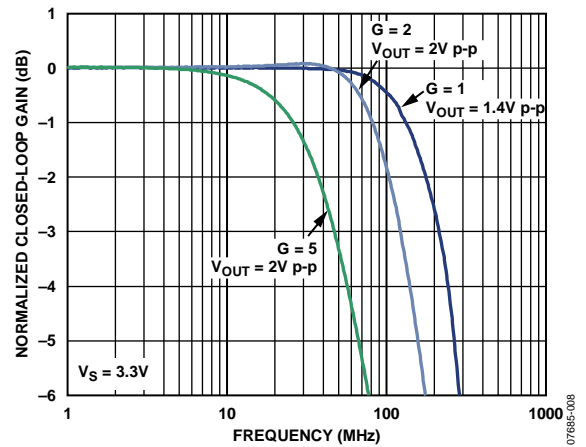

Figure 9. Large Signal Frequency Response vs. Gain

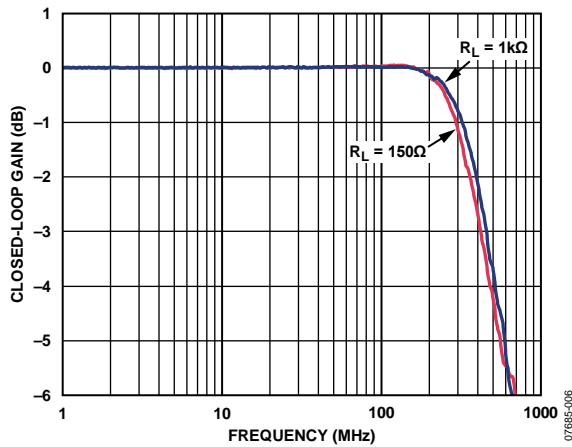

Figure 7. Small Signal Frequency Response vs. Load

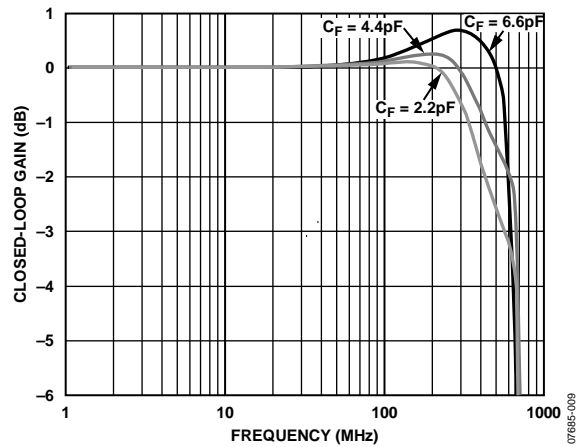

Figure 10. Small Signal Frequency Response vs. Capacitive Load

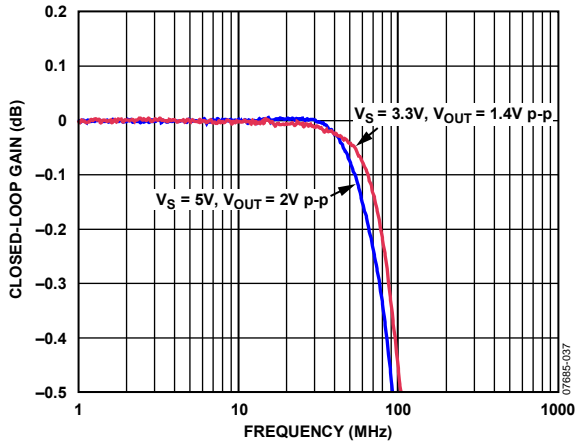

Figure 11. 0.1 dB Flatness vs. Supply Voltage

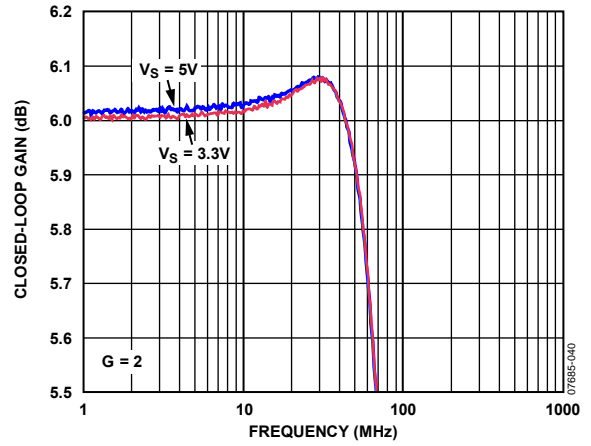

Figure 14. 0.1 dB Flatness vs. Supply Voltage

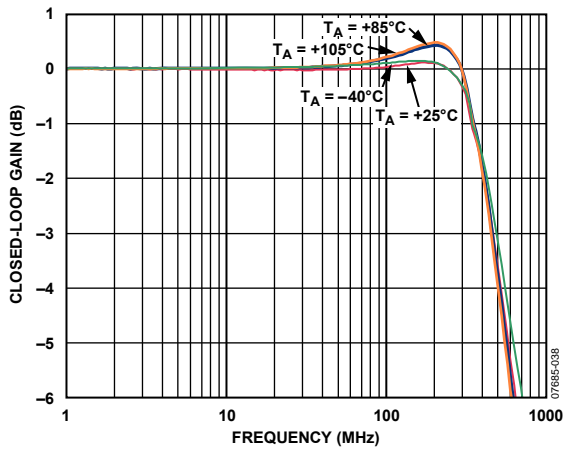

Figure 12. Small Signal Frequency Response vs. Temperature

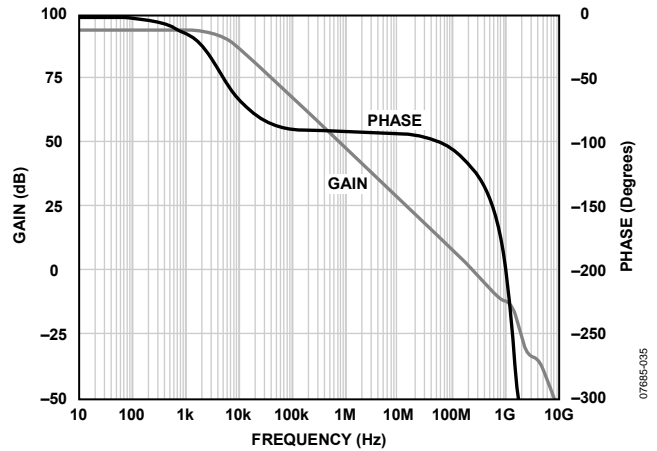

Figure 15. Open-Loop Gain and Phase vs. Frequency

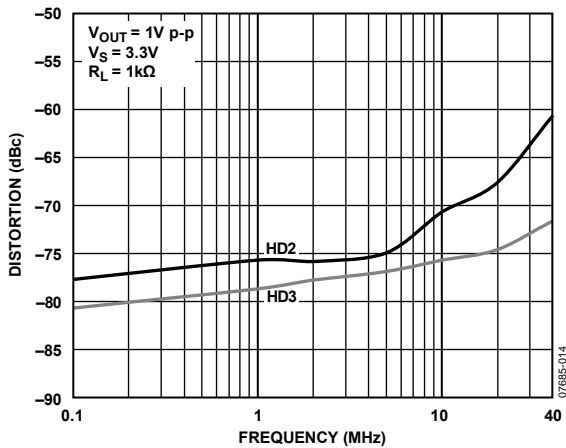

Figure 13. Harmonic Distortion vs. Frequency

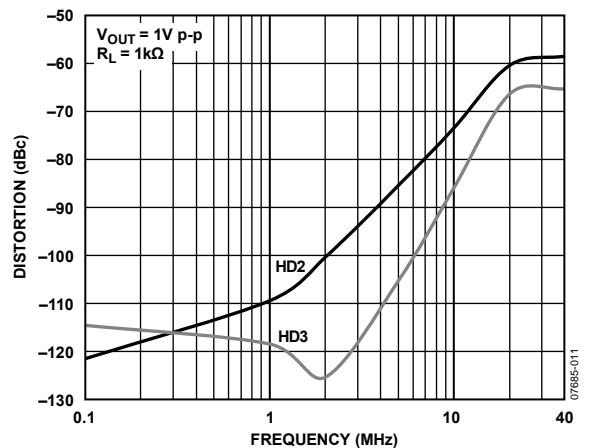

Figure 16. Harmonic Distortion vs. Frequency

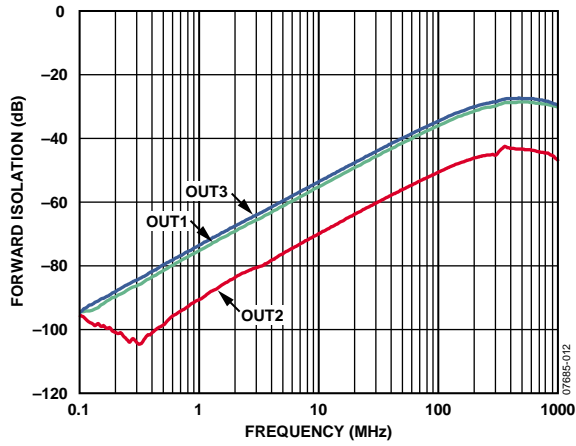

Figure 17. Forward Isolation vs. Frequency

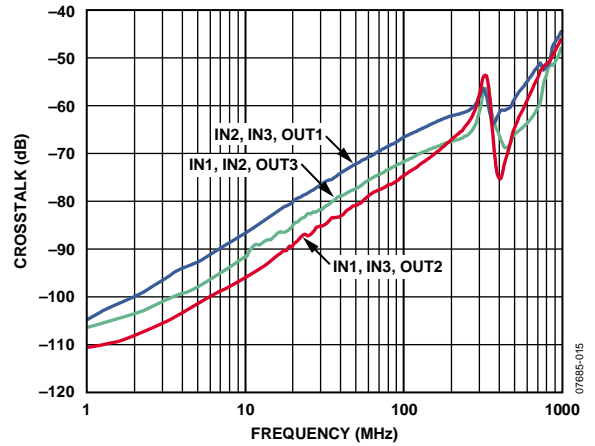

Figure 20. Crosstalk vs. Frequency

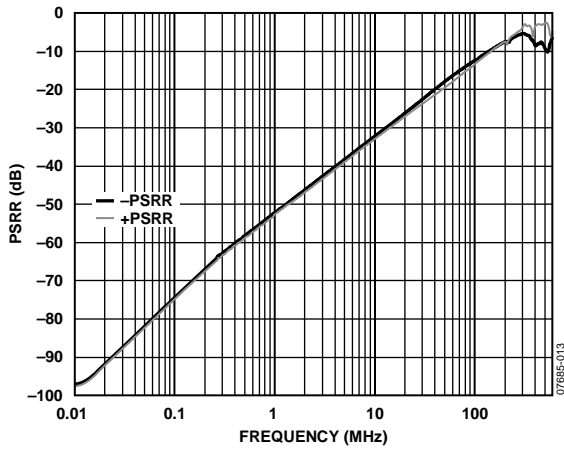

Figure 18. Power Supply Rejection Ratio (PSRR) vs. Frequency

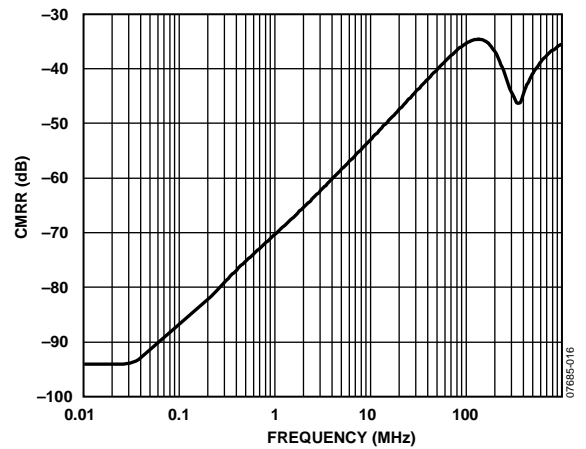

Figure 21. Common-Mode Rejection Ratio (CMRR) vs. Frequency

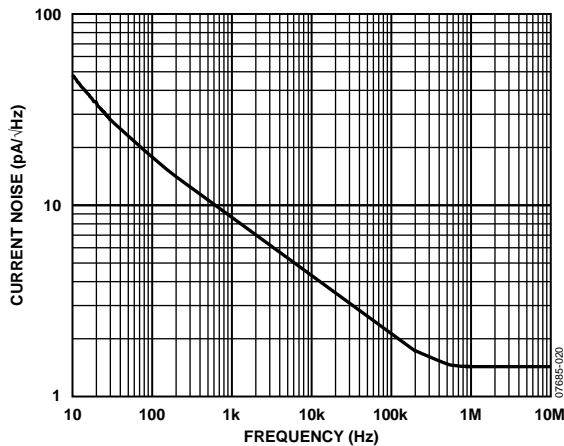

Figure 19. Input Current Noise vs. Frequency

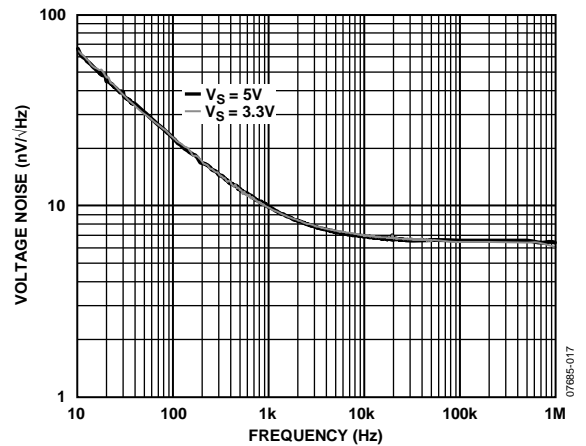

Figure 22. Input Voltage Noise vs. Frequency

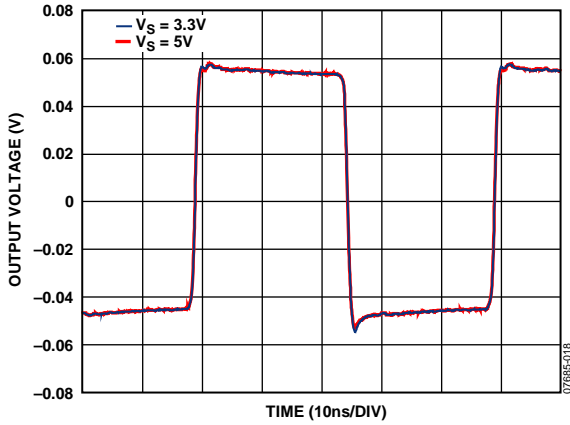

Figure 23. Small Signal Transient Response vs. Supply Voltage

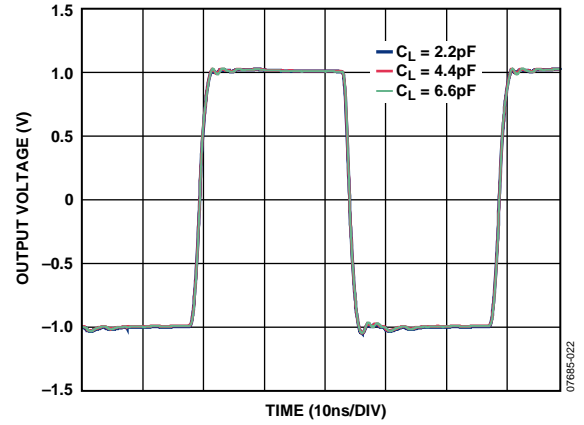

Figure 26. Large Signal Transient Response vs. Capacitive Load

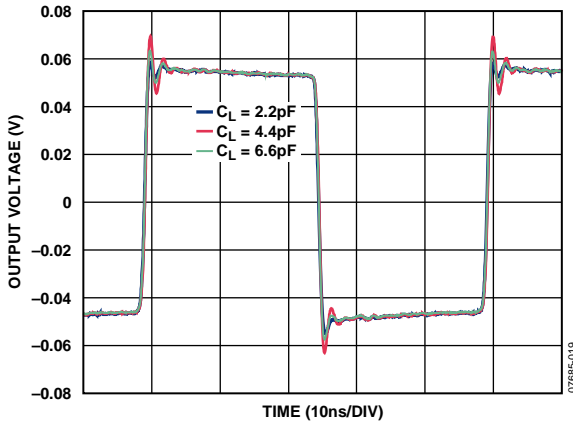

Figure 24. Small Signal Transient Response vs. Capacitive Load

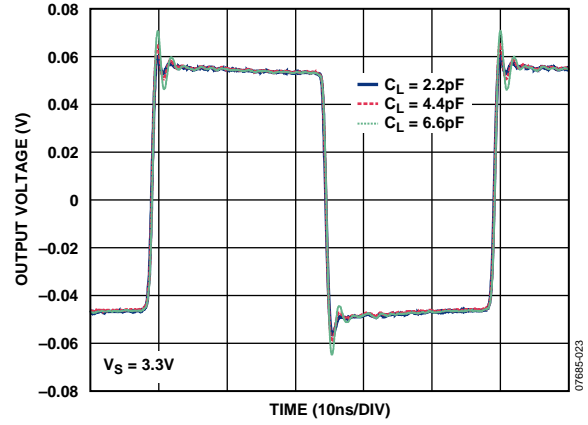

Figure 27. Small Signal Transient Response vs. Capacitive Load

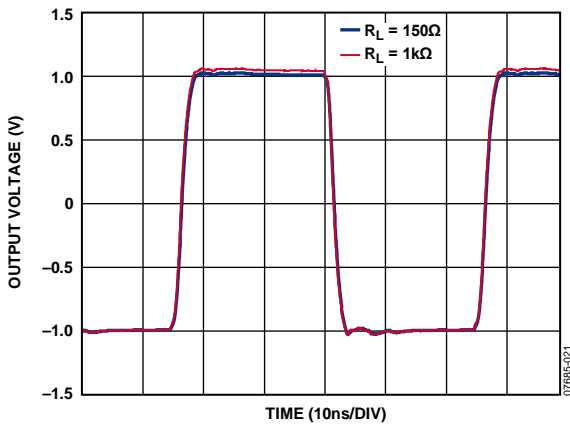

Figure 25. Large Signal Transient Response vs. Load Resistance

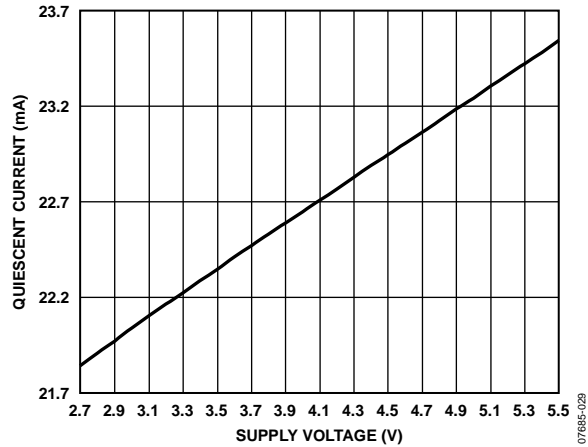

Figure 28. Quiescent Current vs. Supply Voltage

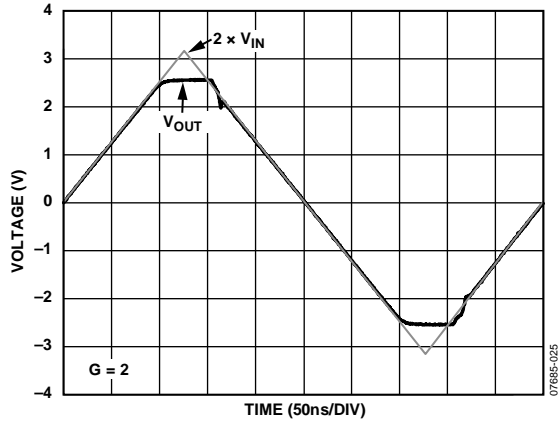

Figure 29. Output Overdrive Recovery

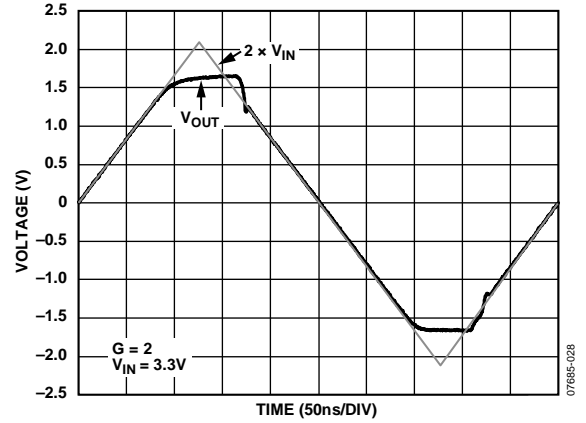

Figure 32. Output Overdrive Recovery

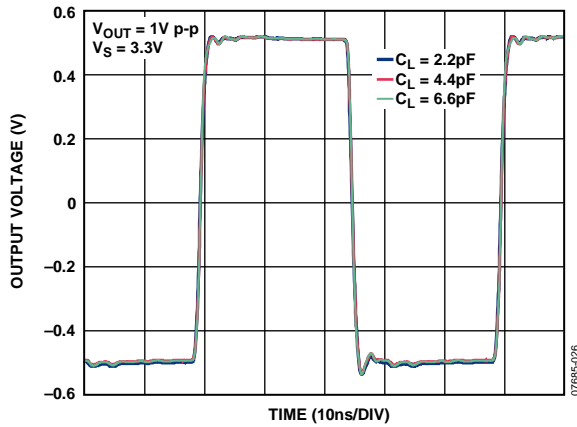

Figure 30. Large Signal Transient Response vs. Capacitive Load

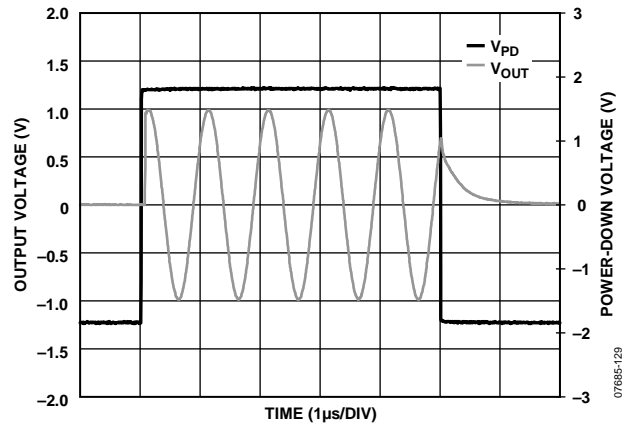

Figure 33. Turn-On/Turn-Off Time

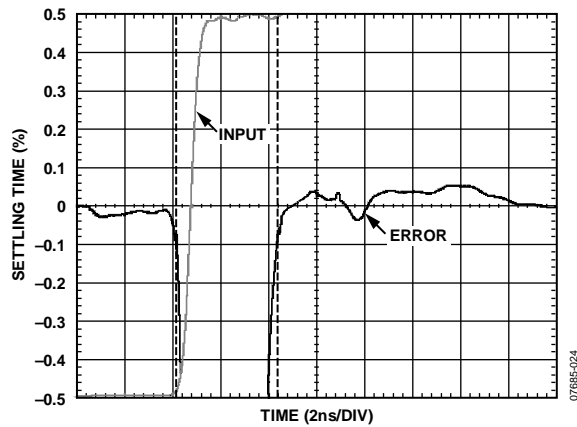

Figure 31. Settling Time

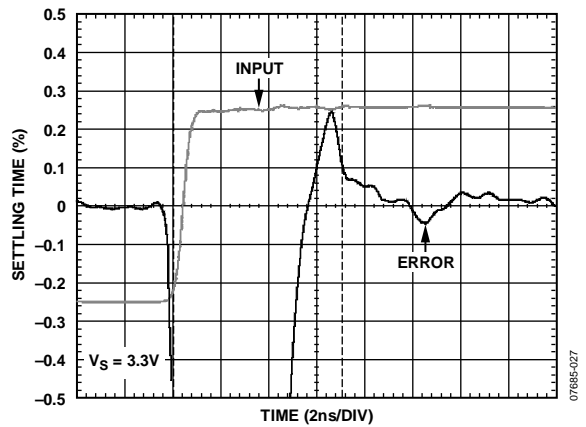

Figure 34. Settling Time

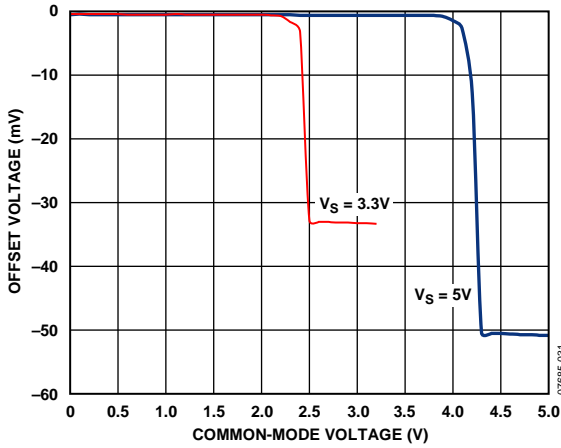

Figure 35. Input Offset Voltage vs. Common-Mode Voltage

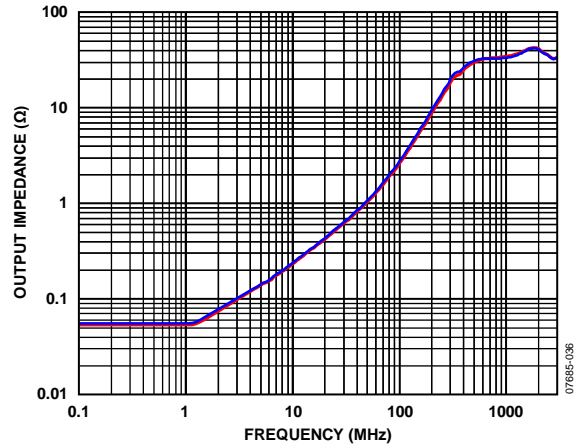

Figure 38. Output Impedance vs. Frequency

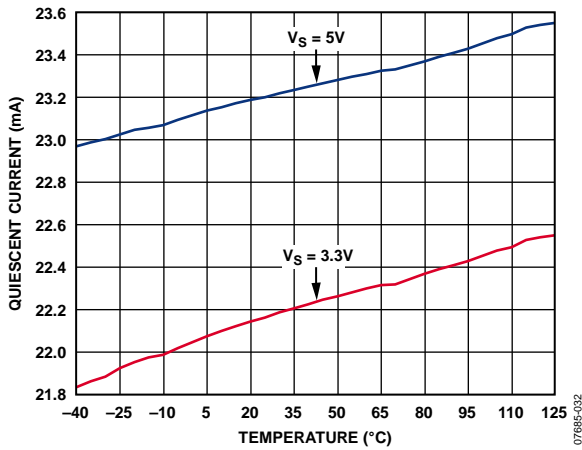

Figure 36. Quiescent Current vs. Temperature

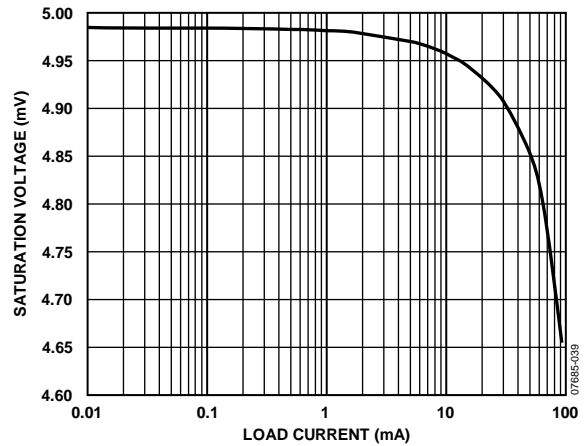

Figure 39. Output Saturation Voltage vs. Load Current

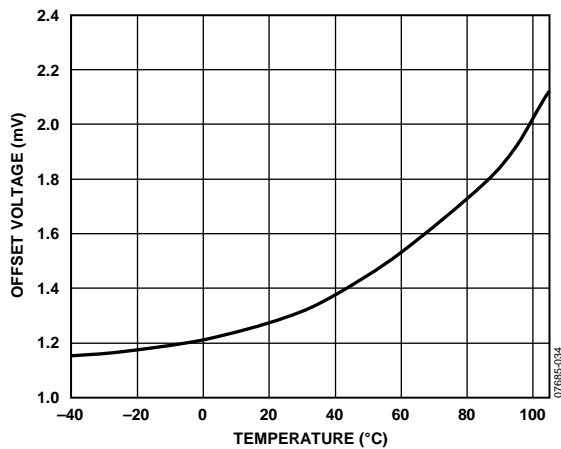

Figure 37. Offset Drift vs. Temperature

TEST CIRCUITS

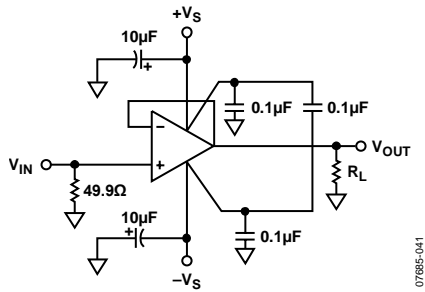

Figure 40. Noninverting Load Configuration

07685-041

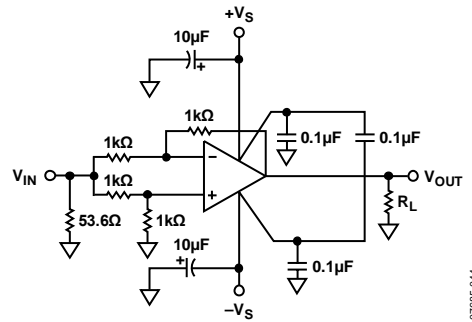

Figure 43. Common-Mode Rejection

07685-044

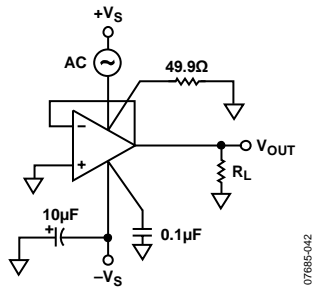

Figure 41. Positive Power Supply Rejection

07685-042

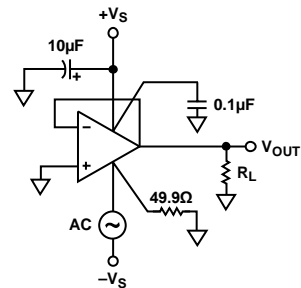

Figure 44. Negative Power Supply Rejection

07685-045

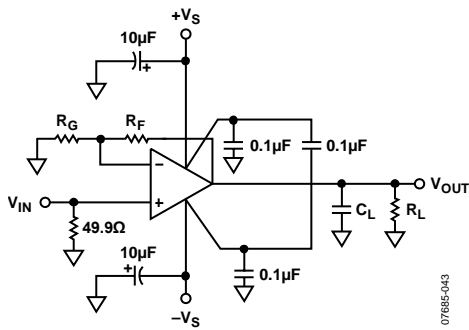

Figure 42. Typical Capacitive Load Configuration

07685-043

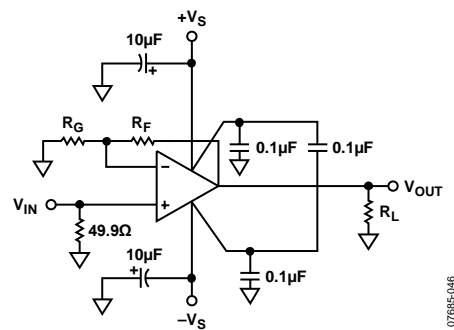

Figure 45. Typical Noninverting Gain Configuration

07685-046

## THEORY OF OPERATION

The ADA4855-3 is a voltage feedback op amp that employs a new input stage that achieves a high slew rate while maintaining a wide common-mode input range. The input common-mode range of the ADA4855-3 extends from 200 mV below the negative rail to 1 V below the positive rail. This feature makes the ADA4855-3 ideal for single-supply applications. In addition, this new input stage does not sacrifice noise performance for slew rate. At 6.8 nV/ $\sqrt{\text{Hz}}$ , the ADA4855-3 is one of the lowest noise rail-to-rail output video amplifiers in the market.

Besides a novel input stage, the ADA4855-3 employs the Analog Devices, Inc., patented rail-to-rail output stage. This output stage makes efficient use of the power supplies, allowing the op amp to drive up to three video loads to within 350 mV of the positive power rail. In addition, this output stage provides the amplifier with very fast overdrive characteristics, which is an important property in video applications.

The ADA4855-3 comes in a 16-lead LFCSP that has an exposed thermal pad for lower operating temperature. This pad is internally connected to the negative rail. To avoid printed circuit board (PCB) layout problems, the ADA4855-3 features a new pinout flow that is optimized for video applications. As shown in Figure 4, the noninverting input and output pins of each amplifier are adjacent to each other for ease of layout.

The ADA4855-3 is fabricated in Analog Devices dielectrically isolated eXtra Fast Complementary Bipolar 3 (XFCB3) process, which results in the outstanding speed and dynamic range displayed by the amplifier.

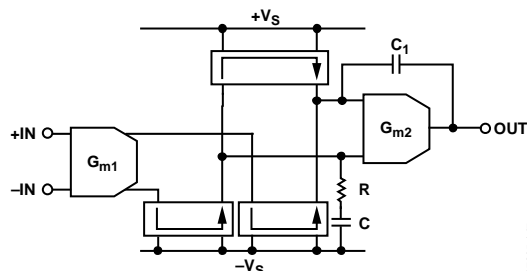

Figure 46. High Level Design Schematic

07885-1.47

# APPLICATIONS INFORMATION

## GAIN CONFIGURATIONS

The ADA4855-3 is a single-supply, high speed, voltage feedback amplifier. Table 6 provides a convenient reference for quickly determining the feedback and gain set resistor values and bandwidth for common gain configurations.

Table 6. Recommended Values and Frequency Performance<sup>1</sup>

Gain	R <sub>F</sub>	R <sub>G</sub>	-3 dB SS BW (MHz)	Large Signal 0.1 dB Flatness (MHz)
1	0 Ω	N/A	200	53
2	1 kΩ	1 kΩ	120	50
5	1 kΩ	200 Ω	45	6

<sup>1</sup> Conditions: V<sub>S</sub> = 5 V, T<sub>A</sub> = 25°C, R<sub>L</sub> = 150 Ω.

Figure 47 and Figure 48 show the typical noninverting and inverting configurations and recommended bypass capacitor values.

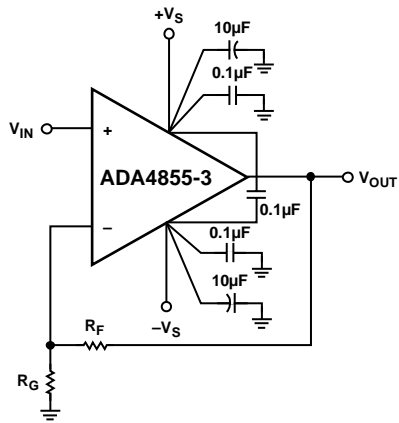

Figure 47. Noninverting Gain Configuration

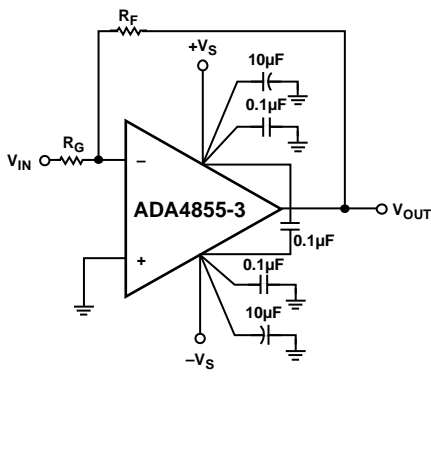

Figure 48. Inverting Gain Configuration

## 20 MHz ACTIVE LOW-PASS FILTER

The ADA4855-3 triple amplifier lends itself to higher order active filters. Figure 49 shows a 20 MHz, 6-pole, Sallen-Key low-pass filter.

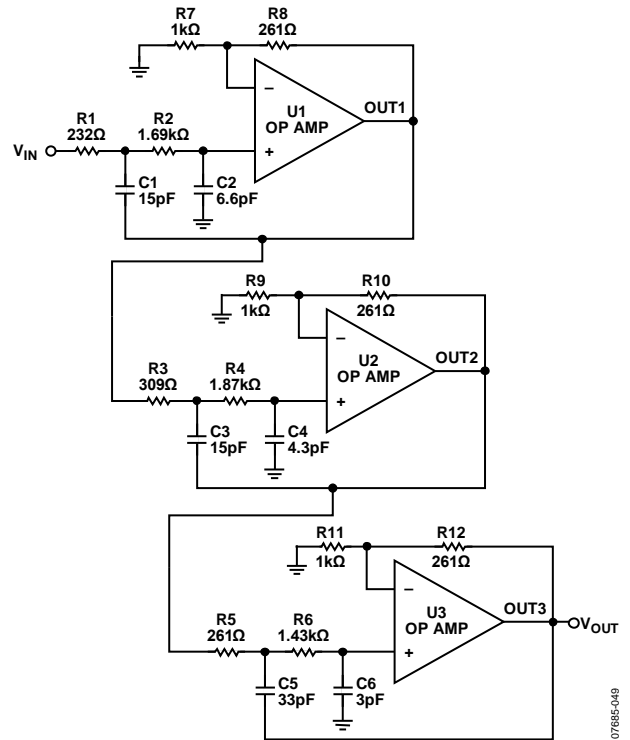

Figure 49. 20 MHz, 6-Pole Low-Pass Filter

The filter has a gain of approximately 6 dB and flat frequency response out to 14 MHz. This type of filter is commonly used at the output of a video DAC as a reconstruction filter. The frequency response of the filter is shown in Figure 50.

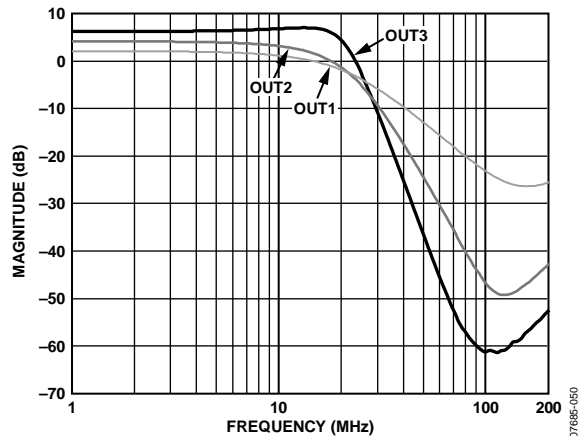

Figure 50. 20 MHz, Low-Pass Filter Frequency Response

**RGB VIDEO DRIVER**

Figure 51 shows a typical RGB driver application using dual supplies. The gain of the amplifier is set at +2, where  $R_F = R_G = 1\text{ k}\Omega$ . The amplifier inputs are terminated with shunt  $75\ \Omega$  resistors, and the outputs have series  $75\ \Omega$  resistors for proper video matching. In Figure 51, the  $\overline{\text{PD}}$  pin is not shown connected to any signal source for simplicity. If the power-down function is not used, it is recommended that the  $\overline{\text{PD}}$  pin be tied to the positive supply or be left floating (not connected).

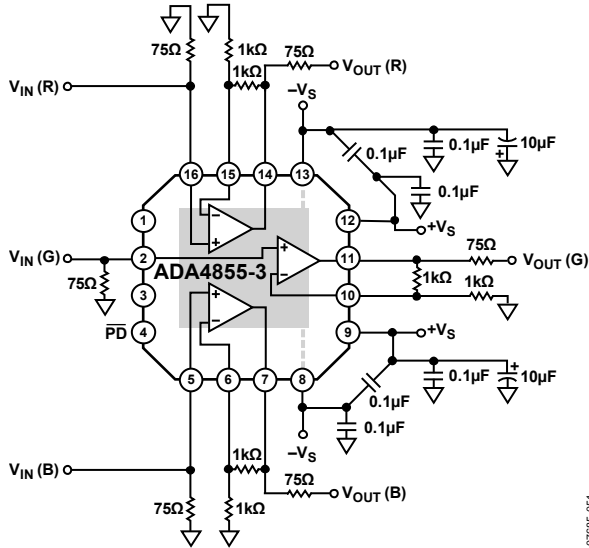

Figure 51. RGB Video Driver

**DRIVING MULTIPLE VIDEO LOADS**

Each amplifier in the ADA4855-3 can drive up to three video loads simultaneously, as shown in Figure 52. When driving three video loads, the ADA4855-3 maintains its excellent performance for 0.1 dB flatness and 3 dB bandwidth. Figure 53 shows the large signal frequency response of the ADA4855-3 with three different load configurations: 150  $\Omega$ , 75  $\Omega$  and 50  $\Omega$ .

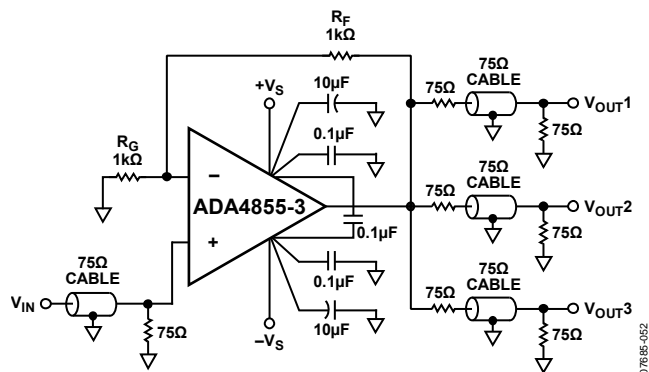

Figure 52. Video Driver Schematic for Triple Video Loads

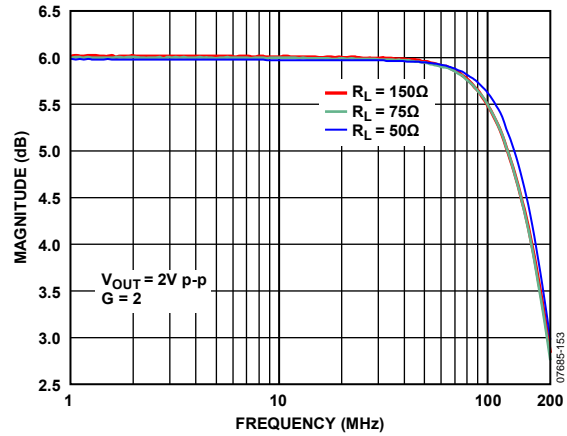

Figure 53. Large Signal Frequency Response vs. Loads

**$\overline{\text{PD}}$  (POWER-DOWN) PIN**

The ADA4855-3 is equipped with a  $\overline{\text{PD}}$  (power-down) pin for all three amplifiers. This allows the user to reduce the quiescent supply current when an amplifier is inactive. The power-down threshold levels are derived from the voltage applied to the  $+V_S$  pin. When used in single-supply applications, this is especially useful with conventional logic levels. The amplifier is enabled when the voltage applied to the  $\overline{\text{PD}}$  pin is greater than  $+V_S - 1.25\text{ V}$ . In a single-supply application, the voltage threshold is typically  $+3.75\text{ V}$ , and in a  $\pm 2.5\text{ V}$  dual-supply application, the voltage threshold is typically  $+1.25\text{ V}$ . The amplifier is also enabled when the  $\overline{\text{PD}}$  pin is left floating (not connected). However, the amplifier is powered down when the voltage on the  $\overline{\text{PD}}$  pin is lower than  $2.5\text{ V}$  from  $+V_S$ . If the  $\overline{\text{PD}}$  pin is not used, it is best to connect it to the positive supply.

Table 7. Power-Down Voltage Control

PD Pin	5 V	$\pm 2.5\text{ V}$	3 V
Not Active	$>3.75\text{ V}$	$>1.25\text{ V}$	$>1.75\text{ V}$
Active	$<2\text{ V}$	$<0\text{ V}$	$<1\text{ V}$

## SINGLE-SUPPLY OPERATION

The ADA4855-3 is designed for a single power supply. Figure 54 shows the schematic for a single 5 V supply video driver. The input signal is ac-coupled into the amplifier via C1. Resistor R2 and Resistor R4 establish the input midsupply reference for the amplifier. C5 prevents constant current from being drawn through the gain set resistor. C6 is the output coupling capacitor. For more information on ac-coupled single-supply operation of op amps, see *Avoiding Op-Amp Instability Problems in Single-Supply Applications*, Analog Dialogue, Volume 35, Number 2, March-May, 2001, at [www.analog.com](http://www.analog.com).

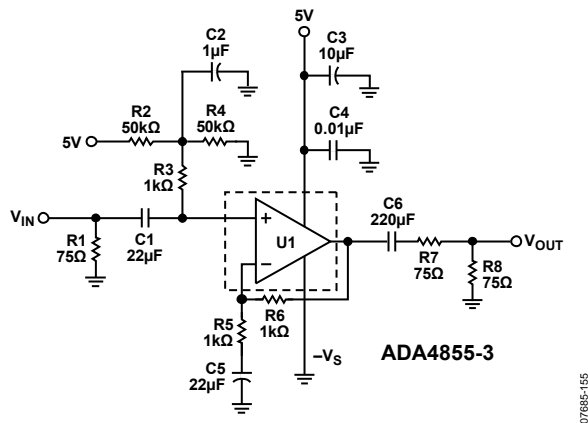

Figure 54. AC-Coupled, Single-Supply Video Driver Schematic

Another way to configure the ADA4855-3 in single-supply operation is dc-coupled. The common-mode input voltage can go  $\sim 200$  mV below ground, which makes it a true single-supply amplifier. However, in video applications, the black level is set at 0 V, which means that the output of the amplifier must go to ground level as well. The ADA4855-3 has a rail-to-rail output that can swing to within 100 mV from either rail. Figure 55 shows the schematic for adding 50 mV dc offset to the input signal so that the output is not clipped while still properly terminating the input with 75  $\Omega$ .

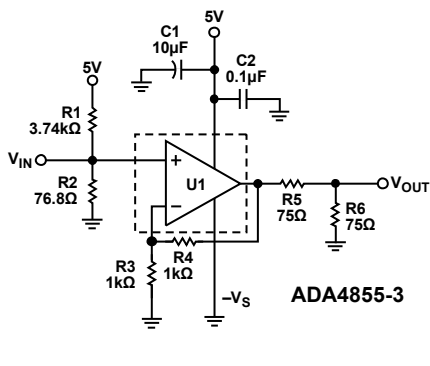

Figure 55. DC-Coupled, Single-Supply Video Driver Schematic

## POWER SUPPLY BYPASSING

Careful attention must be paid to bypassing the power supply pins of the ADA4855-3. High quality capacitors with low equivalent series resistance (ESR), such as multilayer ceramic capacitors (MLCCs), should be used to minimize supply voltage ripple and power dissipation. A large, usually tantalum, 2.2  $\mu$ F to 47  $\mu$ F capacitor located in close proximity to the ADA4855-3 is required to provide good decoupling for lower frequency signals. The actual value is determined by the circuit transient and frequency requirements. In addition, 0.1  $\mu$ F MLCC decoupling capacitors should be located as close to each of the power supply pins and across both supplies as is physically possible, no more than 1/8-inch away. The ground returns should terminate immediately into the ground plane. Locating the bypass capacitor return close to the load return minimizes ground loops and improves performance.

## LAYOUT

As is the case with all high speed applications, careful attention to printed circuit board (PCB) layout details prevents associated board parasitics from becoming problematic. The ADA4855-3 can operate at up to 410 MHz; therefore, proper RF design techniques must be employed. The PCB should have a ground plane covering all unused portions of the component side of the board to provide a low impedance return path. Removing the ground plane on all layers from the area near and under the input and output pins reduces stray capacitance. Signal lines connecting the feedback and gain resistors should be kept as short as possible to minimize the inductance and stray capacitance associated with these traces. Termination resistors and loads should be located as close as possible to their respective inputs and outputs. Input and output traces should be kept as far apart as possible to minimize coupling (crosstalk) through the board. Adherence to microstrip or stripline design techniques for long signal traces (greater than 1 inch) is recommended. For more information on high speed board layout, see *A Practical Guide to High-Speed Printed-Circuit-Board Layout*, Analog Dialogue, Volume 39, September 2005, at [www.analog.com](http://www.analog.com).

OUTLINE DIMENSIONS

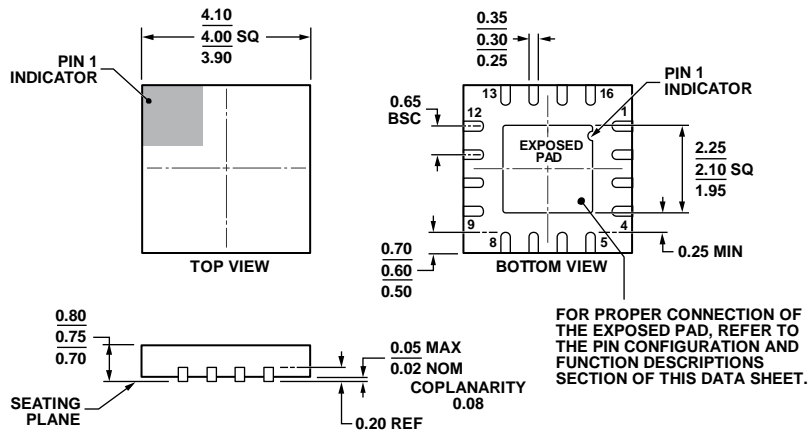

COMPLIANT TO JEDEC STANDARDS MO-220-WGGC.

Figure 56.16-Lead Lead Frame Chip Scale Package [LFCSP\_WQ]  
 4 mm × 4 mm Body, Very Very Thin Quad  
 (CP-16-23)  
 Dimensions shown in millimeters

111908-A

ORDERING GUIDE

Model <sup>1</sup>	Temperature Range	Package Description	Package Option	Ordering Quantity
ADA4855-3YCPZ-R2	-40°C to +105°C	16-Lead LFCSP_WQ	CP-16-23	250
ADA4855-3YCPZ-R7	-40°C to +105°C	16-Lead LFCSP_WQ	CP-16-23	1,500
ADA4855-3YCPZ-RL	-40°C to +105°C	16-Lead LFCSP_WQ	CP-16-23	5,000
ADA4855-3YCP-EBZ		Evaluation Board		

<sup>1</sup> Z = RoHS Compliant Part.

**NOTES**

**NOTES**