

Brief Description

The ZSSC3138 is a member of the ZSSC313x product family of CMOS integrated circuits designed for automotive/ industrial sensor applications. All family members are well suited for highly accurate amplification and sensor-specific correction of resistive bridge sensor signals. An internal 16-bit RISC microcontroller running a correction algorithm compensates sensor offset, sensitivity, temperature drift, and non-linearity of the connected sensor element. The required calibration coefficients are stored by the one-pass calibration procedure on chip (EEPROM).

The ZSSC3138 offers a maximum analog gain of 420 and two offset compensation features. These fit perfectly with the requirements of ceramic thick-film-based sensor elements as well as strain gauges. The high amplification in combination with the offset compensation offers the capability to set up ceramic thick-film-based sensor applications without laser trimming, which leads to better long-term stability.

Features

- Adjustable to nearly all resistive bridge sensor types, analog gain of 420, maximum overall gain of 1680
- Enhanced sample rate: 7.8 kHz maximum
- High ADC resolution 15/16 bit
- Safety functionality sensor connection
- Internal temperature compensation
- Digital compensation of sensor offset, sensitivity, temperature drift, and non-linearity
- Output options: ratiometric analog voltage output (5 - 95% maximum, 12.4 bit resolution) or ZACwire™ (digital One-Wire Interface (OWI))
- Sensor biasing by voltage
- High voltage protection up to 33 V
- Supply current: 5.5mA maximum
- Reverse polarity and short circuit protection
- Wide operation temperature range between -40 to +150°C
- Traceability by user-defined EEPROM entries

* Note: I²C™ is a trademark of NXP.

** FSO = Full Scale Output.

Benefits

- Family approach offers the best fitting IC selection to build cost-optimized applications
- No external trimming components required
- Low number of external components needed
- PC-controlled configuration and one-pass/end-of-line calibration via I²C™* or ZACwire™ interface: simple, cost efficient, quick, and precise
- High accuracy (0.25% FSO** @ -25 to +85°C; 0.5% FSO @ -40 to +125°C)
- Optimized for automotive/industrial environments due to robust protection circuitries, excellent electromagnetic compatibility and AEC-Q100 qualification

Available Support

- Evaluation Kits
- Application Notes
- Mass Calibration System

Physical Characteristics

- Supply voltage 4.5 to 5.5 V
- Operation temperature: -40°C to +125°C (-40°C to +150°C extended temperature range depending on product version)
- Available in RoHS-compliant JEDEC-SSOP14 package or delivery as die

ZSSC3138 Minimum Application Requirements

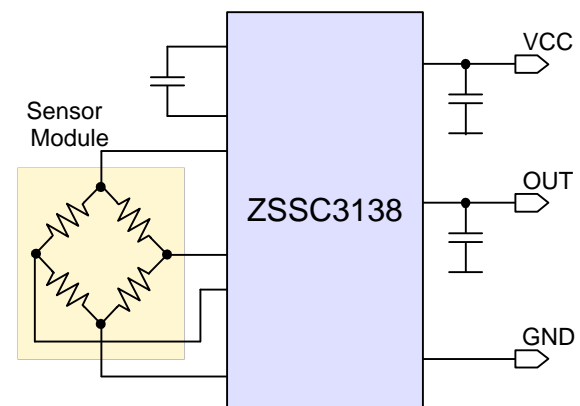

ZSSC3138 Application Example

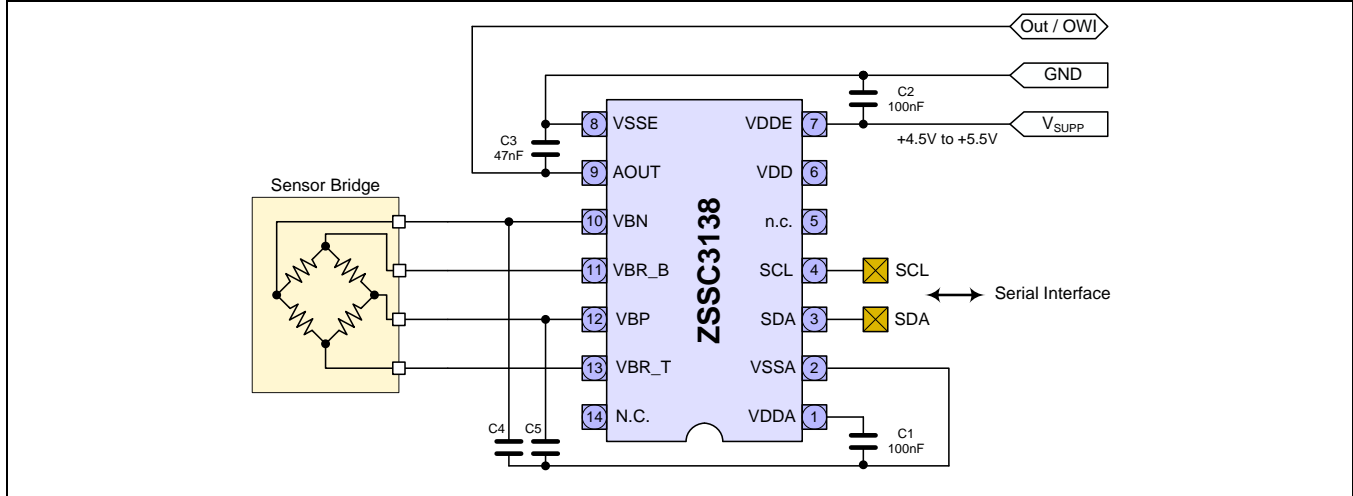

Ordering Information *(See data sheet section 8 for complete delivery options.)*

Product Sales Code	Description	Package
ZSSC3138BE1	ZSSC3138 die – tested; temperature range -40 to +150°C	Unsawn wafer: add “B” to sales code Die on frame: add “C” to sales code
ZSSC3138BA1	ZSSC3138 die – tested; temperature range -40 to +125°C	Unsawn wafer: add “B” to sales code Die on frame: add “C” to sales code
ZSSC3138BE2	ZSSC3138 SSOP14 – temperature range -40 to +150°C	Tube: add “T” to sales code Tape & Reel: add “R”
ZSSC3138BA2	ZSSC3138 SSOP14 – temperature range -40 to +125°C	Tube: add “T” to sales code Tape & Reel: add “R”
ZSSC313xKITV1.1	ZSSC313x Evaluation Kit, version 1.1, including Evaluation Board, ZSSC3138 IC samples, USB cable	Kit
ZSSC313x Mass Calibration System V1.1	Modular Mass Calibration System (MSC) for ZSSC313x including MCS boards, cable, connectors	Kit



Corporate Headquarters
6024 Silver Creek Valley Road
San Jose, CA 95138
www.IDT.com

Sales
1-800-345-7015 or 408-284-8200
Fax: 408-284-2775
www.IDT.com/go/sales

Tech Support
www.IDT.com/go/support

DISCLAIMER Integrated Device Technology, Inc. (IDT) reserves the right to modify the products and/or specifications described herein at any time, without notice, at IDT's sole discretion. Performance specifications and operating parameters of the described products are determined in an independent state and are not guaranteed to perform the same way when installed in customer products. The information contained herein is provided without representation or warranty of any kind, whether express or implied, including, but not limited to, the suitability of IDT's products for any particular purpose, an implied warranty of merchantability, or non-infringement of the intellectual property rights of others. This document is presented only as a guide and does not convey any license under intellectual property rights of IDT or any third parties.

IDT's products are not intended for use in applications involving extreme environmental conditions or in life support systems or similar devices where the failure or malfunction of an IDT product can be reasonably expected to significantly affect the health or safety of users. Anyone using an IDT product in such a manner does so at their own risk, absent an express, written agreement by IDT.

Integrated Device Technology, IDT and the IDT logo are trademarks or registered trademarks of IDT and its subsidiaries in the United States and other countries. Other trademarks used herein are the property of IDT or their respective third party owners. For datasheet type definitions and a glossary of common terms, visit www.idt.com/go/glossary. All contents of this document are copyright of Integrated Device Technology, Inc. All rights reserved.

Contents

1	Electrical Characteristics	5
1.1.	Absolute Maximum Ratings	5
1.2.	Operating Conditions	5
1.3.	Electrical Parameters	6
1.3.1.	Supply Current and System Operation Conditions	6
1.3.2.	Analog Front-End (AFE) Characteristics	6
1.3.3.	Temperature Measurement	6
1.3.4.	A/D Conversion	6
1.3.5.	Sensor Check.....	7
1.3.6.	DAC and Analog Output	7
1.3.7.	System Response	8
1.4.	Interface Characteristics and EEPROM	9
1.4.1.	I ² C™ Interface	9
1.4.2.	ZACwire™ One-Wire Interface (OWI)	9
1.4.3.	EEPROM.....	9
2	Circuit Description	10
2.1.	Signal Flow	10
2.2.	Application Modes	11
2.3.	Analog Front-End (AFE)	11
2.3.1.	Programmable Gain Amplifier (PGA).....	12
2.3.2.	Offset Compensation	12
2.3.3.	Measurement Cycle	13
2.3.4.	Analog-to-Digital Converter.....	14
2.4.	Temperature Measurement	16
2.5.	System Control and Conditioning Calculation	16
2.5.1.	General Working Modes	16
2.5.2.	Startup Phase	17
2.5.3.	Conditioning Calculation	17
2.6.	Analog or Digital Output	18
2.7.	Serial Digital Interface	18
2.8.	Failsafe Features	18
2.9.	High Voltage, Reverse Polarity, and Short Circuit Protection	19
3	Application Circuit Examples.....	20
4	Pin Configuration and Package.....	21
5	ESD Protection	22
6	Quality and Reliability.....	22
7	Customization.....	22
8	Ordering Information	22

9	Related Documents.....	23
10	Glossary	24
11	Document Revision History.....	25

List of Figures

Figure 2.1	Block Diagram of the ZSSC3138.....	10
Figure 2.2	Measurement Cycle with 1 Bridge Sensor Signal Measurement per Special Measurement.....	14
Figure 3.1	Application with On-Chip Diode Temperature Sensor.....	20
Figure 4.1	ZSSC3138 SSOP14 Pin Diagram	21

List of Tables

Table 1.1	Absolute Maximum Ratings	5
Table 1.2	Operating Conditions	5
Table 1.3	Electrical Parameters.....	6
Table 1.4	Interface Characteristics and EEPROM	9
Table 2.1	Adjustable Gains, Resulting Sensor Signal Spans and Common Mode Ranges	12
Table 2.2	Extended Analog Zero Compensation Ranges (XZC)	13
Table 2.3	ADC Resolution versus Output Resolution and Sample Rate.....	16
Table 3.1	External Components for Application Circuit Examples	20
Table 4.1	Pin Configuration and Definition	21

1 Electrical Characteristics

1.1. Absolute Maximum Ratings

Parameters apply in operation temperature range and without time limitations.

Table 1.1 Absolute Maximum Ratings

No.	Parameter	Symbol	Conditions	Min	Max	Unit
1.1.1	Supply voltage ¹⁾	VDDE _{AMR}	To VSSE, refer to section 3 for application circuits	-33	33	VDC
1.1.2	Potential at AOUT pin ¹⁾	V _{OUT}	Referenced to VSSE	-33	33	VDC
1.1.3	Analog supply voltage ¹⁾	VDDA _{AMR}	Referenced to VSSA, VDDE - VDDA < 0.35V	-0.3	6.5	VDC
1.1.4	Voltage at all analog and digital IO pins	V _{A_IO} V _{D_IO}	Referenced to VSSA	-0.3	VDDA + 0.3	VDC
1.1.5	Storage temperature	T _{STG}		-55	150	°C

1) Refer to the ZSSC313x High Voltage Protection Description for specification and detailed conditions.

1.2. Operating Conditions

All voltages are referenced to VSSA.

Table 1.2 Operating Conditions

No.	Parameter	Symbol	Conditions	Min	Typ	Max	Unit
1.2.1	Ambient temperature ^{1) 2)}	T _{AMB_TQE}	Extended Temperature Range (TQE)	-40		150	°C
		T _{AMB_TQA}	Advanced-Performance Temperature Range (TQA)	-40		125	°C
		T _{AMB_TQI}	Best-Performance Temperature Range (TQI)	-25		85	°C
1.2.2	Supply voltage	VDDE		4.5	5.0	5.5	VDC
1.2.3	Bridge resistance ^{3) 4)}	R _{BR}		2		25	kΩ

1) Maximum operation temperature range depends on product version (refer to section 8).
 2) See the temperature profile description in the ZSSC313x Dice Package Document.
 3) No measurement in mass production, parameter is guaranteed by design and/or quality observation.
 4) Symmetric behavior and identical electrical properties (especially the low pass characteristic) of both sensor inputs of the ZSSC3138 are required. Unsymmetrical conditions of the sensor and/or external components connected to the sensor input pins of the ZSSC3138 can generate a failure in signal operation.

1.3. Electrical Parameters

All parameter values are valid under the operating conditions specified in section 1.2 (special definitions excluded). All voltages referenced to VSSA.

Note: See important notes at the end of Table 1.3.

Table 1.3 Electrical Parameters

No.	Parameter	Symbol	Conditions	Min	Typ	Max	Unit
1.3.1. Supply Current and System Operation Conditions							
1.3.1.1	Supply current	I_S	Without bridge and load current, $f_{OSC} \leq 3$ MHz			5.5	mA
1.3.1.2	Oscillator frequency ¹⁾	f_{OSC}	Adjustment guaranteed for whole temperature range (T_{AMB_TQE})	2	3	4	MHz
1.3.2. Analog Front-End (AFE) Characteristics							
1.3.2.1	Input span	V_{IN_SP}	Analog gain: 105 to 2.8 Analog gain: 420 to 2.8	8 1		275 275	mV/V mV/V
1.3.2.2	Parasitic differential input offset current ¹⁾	I_{IN_OFF}	Temperature range T_{AMB_TQE}	-10		10	nA
			Temperature range T_{AMB_TQI}	-2		2	nA
1.3.2.3	Common mode input range	V_{IN_CM}	Depends on gain adjust; XZC off (refer to section 2.3.1)	0.29		0.65	VDDA
1.3.2.4	Analog offset compensation range		Depends on gain adjustment; refer to section 2.3.2	-300		300	% V_{IN_SP}
1.3.3. Temperature Measurement (Refer to section 2.4.)							
1.3.3.1	Internal temperature diode sensitivity	ST_{TSI}	Raw values, without conditioning	700		2700	ppm FS / K
1.3.4. A/D Conversion							
1.3.4.1	A/D resolution ¹⁾	r_{ADC}		13		16	Bit
1.3.4.2	DNL ¹⁾	DNL_{ADC}	$r_{ADC}=13$ bit, $f_{OSC}=3$ MHz, best fit, complete AFE, range according to 1.3.4.5			0.95	LSB

No.	Parameter	Symbol	Conditions	Min	Typ	Max	Unit
1.3.4.3	INL TQA	INL _{ADC}	r _{ADC} =13bit, f _{OSC} =3MHz, best fit, complete AFE, range according to 1.3.4.5			4	LSB
1.3.4.4	INL TQE	INL _{ADC_TQE}	r _{ADC} =13bit, f _{OSC} =3MHz, best fit, complete AFE, range according to 1.3.4.5, temperature range T _{AMB_TQE}			5	LSB
1.3.4.5	ADC input range	V _{ADC_IN}		0.1		0.9	VDDA
1.3.5. Sensor Check							
1.3.5.1	Sensor connection loss	R _{SSC_min}	Detection threshold	100			kΩ
1.3.5.2	Sensor input short	R _{SSC_short}	Short detection guaranteed	0		50	Ω
1.3.5.3	Sensor input no short	R _{SSC_pass}	Corresponds with minimum sensor output resistance	1000			Ω
1.3.6. DAC and Analog Output							
1.3.6.1	D/A resolution	r _{DAC}	Analog output, 10-90%		12		Bit
1.3.6.2	Output current sink and source for VDDE=5V	I _{OUT_SRC/SINK}	V _{OUT} : 5-95%, R _{LOAD} ≥ 2kΩ			2.5	mA
			V _{OUT} : 10-90%, R _{LOAD} ≥ 1kΩ			5	mA
1.3.6.3	Short circuit current	I _{OUT_max}	To VDDE/VSSE ²⁾	-25		25	mA
1.3.6.4	Output signal range	V _{OUT_RANGE}	With R _{LOAD} ≥ 2kΩ	0.05		0.95	VDDE
			With R _{LOAD} ≥ 1kΩ	0.1		0.90	VDDE
1.3.6.5	Output slew rate ¹⁾	SR _{OUT}	C _{LOAD} < 50nF	0.1			V/μs
1.3.6.6	Output resistance in diagnostic mode	R _{OUT_DM}	Diagnostic range: <4 to 96>%, R _{LOAD} ≥ 2kΩ <8 to 92>%, R _{LOAD} ≥ 1kΩ			82	Ω
1.3.6.7	Load capacitance ¹⁾	C _{LOAD}	C3 + C _{LOAD} (refer to section 3)			150	nF
1.3.6.8	DNL	DNL _{OUT}		-1.5		1.5	LSB
1.3.6.9	INL TQA	INL _{OUT}	Best fit, r _{DAC} =12bit	-5		5	LSB
1.3.6.10	INL TQE	INL _{OUT_TQE}	Best fit, r _{DAC} =12bit, temperature range T _{AMB_TQE}	-8		8	LSB
1.3.6.11	Output leakage current at 150°C	I _{OUT_LEAK}	In case of power or ground loss	-25		25	μA

No.	Parameter	Symbol	Conditions	Min	Typ	Max	Unit
1.3.7. System Response							
1.3.7.1	Startup time ^{1) 3)} (To 1 st output, ROM check disabled)	t_{STARTUP}	1-step ADC, $f_{\text{OSC}}=3\text{MHz}$ $r_{\text{ADC}}=14\text{bit}$			35	ms
			2-step ADC, $f_{\text{OSC}}=3\text{MHz}$, $r_{\text{ADC}}=14\text{bit}$			5	ms
1.3.7.2	Response time ¹⁾ (100% input step; refer to Table 2.3)	t_{RESPONSE}	1-step ADC, $f_{\text{OSC}}=4\text{MHz}$, $r_{\text{ADC}}=13\text{bit}$	8.7	13.1	17.4	ms
			2-step ADC, $f_{\text{OSC}}=4\text{MHz}$, $r_{\text{ADC}}=13\text{bit}$	256	384	512	μs
1.3.7.3	Bandwidth ¹⁾ (In comparison to an equivalent analog SSC. Refer to Table 2.3)	BW	1-step ADC			200	Hz
			2-step ADC			7.8	kHz
1.3.7.4	Analog output noise peak-to-peak ¹⁾	$V_{\text{NOISE_PP}}$	Shorted inputs bandwidth $\leq 10\text{kHz}$			10	mV
1.3.7.5	Analog output noise RMS ¹⁾	$V_{\text{NOISE_RMS}}$	Shorted inputs bandwidth $\leq 10\text{kHz}$			3	mV
1.3.7.6	Ratiometricity error	RE	Maximum error for $V_{\text{DDE}}=5\text{V}$ to $4.5/5.5\text{V}$			1000	ppm
1.3.7.7	Overall failure ⁴⁾ Deviation from ideal line including INL, gain, offset and temperature errors. No sensor-caused effects. Failure for digital readout shown in parenthesis.	$F_{\text{OVERALL_TQI}}$	$f_{\text{OSC}}\leq 3\text{MHz}$, $r_{\text{ADC}}=13\text{bit}$, temperature range $T_{\text{AMB_TQI}}$		0.25 (0.1)		% FS
		$F_{\text{OVERALL_TQA}}$	$f_{\text{OSC}}\leq 3\text{MHz}$, $r_{\text{ADC}}=13\text{bit}$, temperature range $T_{\text{AMB_TQA}}$		0.5 (0.25)		% FS
		$F_{\text{OVERALL_TQE}}$	$f_{\text{OSC}}\leq 3\text{MHz}$, $r_{\text{ADC}}=13\text{bit}$, temperature range $T_{\text{AMB_TQE}}$		1.0 (0.5)		% FS
1) No measurement in mass production, parameter is guaranteed by design and/or quality observation. 2) Minimum output voltage to V_{DDE} or maximum output voltage to V_{SSE} . 3) Depends on resolution and configuration. Start routine begins approximately 0.8ms after power on. 4) If XZC is active, additional overall failure of 25ppm/K for $XZC=31$ maximum. Failure decreases linearly for $XZC<31$.							

1.4. Interface Characteristics and EEPROM

Table 1.4 Interface Characteristics and EEPROM

No.	Parameter	Symbol	Conditions	Min	Typ	Max	Unit
1.4.1. I²C™ Interface (Refer to the ZSSC313x <i>Functional Description</i> for timing details)							
1.4.1.1	I ² C voltage level HIGH	V _{I²C,HIGH}		0.8			VDDA
1.4.1.2	I ² C voltage level LOW ¹⁾	V _{I²C,LOW}				0.2	VDDA
1.4.1.3	Slave output level LOW ¹⁾	V _{I²C,LOW_OUT}	Open drain, I _{OL} <2mA			0.15	VDDA
1.4.1.4	SDA load capacitance ¹⁾	C _{SDA}				400	pF
1.4.1.5	SCL clock frequency ¹⁾	f _{I²C}	f _{OSC} ≥2MHz			400	kHz
1.4.1.6	Internal pull-up resistor ¹⁾	R _{I²C,PULLUP}		25		100	kΩ
1.4.2. ZACwire™ One-Wire Interface (OWI) (Refer to the ZSSC313x <i>Functional Description</i> for timing details)							
1.4.2.1	OWI voltage level HIGH ¹⁾	V _{OWI,HIGH}		0.75			VDDA
1.4.2.2	OWI voltage level LOW ¹⁾	V _{OWI,LOW}				0.2	VDDA
1.4.2.3	Slave output level LOW ¹⁾	V _{OWI,LOW_OUT}	Open drain, I _{OL} <2mA			0.15	VDDA
1.4.2.4	Start window ¹⁾	t _{OWI,STARTWIN}	At f _{OSC} =3MHz	96	175	455	ms
1.4.3. EEPROM							
1.4.3.1	Ambient temperature for EEPROM programming ¹⁾	T _{AMB_EEP}		-40		150	°C
1.4.3.2	Write cycles ¹⁾	n _{EEP,WRI}	Write ≤ 85°C			100 000	
			Write up to 150°C			100	
1.4.3.3	Read cycles ^{1) 2)}	n _{EEP,READ}	≤175°C			8 * 10 ⁸	
1.4.3.4	Data retention ^{1) 3)}	t _{EEP,RETENTION}	1300h at 175°C (= 3000h at 150°C + 27000h at 125°C + 100000h at 55°C)			15	a
1.4.3.5	Programming time ¹⁾	t _{EEP,WRI}	Per written word		12		ms
1) No measurement in mass production, parameter is guaranteed by design and/or quality observation. 2) Valid for the dice. Note that the package and the temperature version causes additional restrictions. 3) Over lifetime and valid for the dice. Use the calculation sheet <i>IDT Temperature Profile Calculation Sheet</i> for temperature stress calculation. Note that the package and the temperature version causes additional restrictions.							

2 Circuit Description

2.1. Signal Flow

The ZSSC3138’s signal path is partly analog and partly digital. The analog section is differential – this means the differential bridge sensor signal is internally handled via two signal lines that are rejected symmetrically around an internal common mode potential (analog ground = $V_{DDA}/2$).

As a result of the differential design, it is possible to amplify positive and negative input signals that are within the common mode range of the signal input.

Figure 2.1 Block Diagram of the ZSSC3138

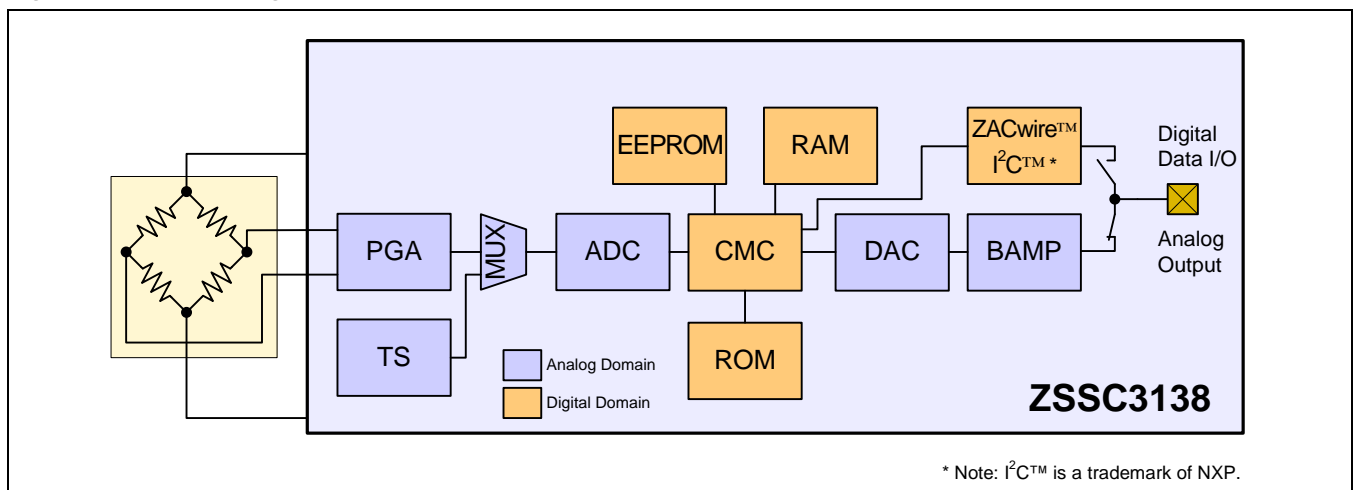

PGA	Programmable Gain Amplifier
TS	On-chip Temperature Sensor (pn-junction)
MUX	Multiplexer
ADC	Analog-to-Digital Converter
CMC	Calibration Microcontroller
ROM	Read-Only Memory for Correction Formula and Algorithm
RAM	Volatile Memory for Calibration Parameters and Configuration
EEPROM	Non-volatile Memory for Calibration Parameters and Configuration
DAC	Digital-to-Analog Converter
BAMP	Output Buffer Amplifier

The differential signal from the bridge sensor is pre-amplified by the programmable gain amplifier (PGA). The multiplexer (MUX) transmits the signals from either the bridge sensor or the internal temperature sensor to the analog-to-digital converter (ADC) in a specific sequence. The ADC converts these signals into digital values.

The digital signal conditioning is processed by the calibration microcontroller (CMC). It is based on a correction formula that uses sensor-specific coefficients determined during calibration. The formula is located in ROM, and the sensor-specific coefficients are stored in EEPROM. Depending on the programmed output configuration, the conditioned sensor signal is output as an analog signal, or alternatively can be readout via a digital serial interface (I²C™ or ZACwire™). The configuration data and the correction parameters must also be programmed into the EEPROM via the digital interfaces.

2.2. Application Modes

For each application, a configuration set must be established by programming the on-chip EEPROM for the following modes:

- Sensor channel
 - Input range: The gain adjustment of the analog front-end (AFE) with respect to the maximum sensor signal span and the zero point of the A/D conversion must be selected.
 - Extended analog offset compensation (XZC): If required, this compensates large sensor offsets; e.g., if the sensor offset voltage is near to or larger than the sensor span.
 - Resolution/response time: The A/D converter must be configured for resolution. The ADC order (first or second order) must also be configured. These settings influence the sampling rate and the signal integration time, and thus, the noise immunity.
- Temperature
 - Temperature measurement

2.3. Analog Front-End (AFE)

The analog front-end (AFE) consists of the three-stage programmable gain amplifier (PGA), the multiplexer (MUX), and the analog-to-digital converter (ADC).

2.3.1. Programmable Gain Amplifier (PGA)

Table 2.1 shows the adjustable gains, the sensor signal spans, and the valid common mode range.

Table 2.1 Adjustable Gains, Resulting Sensor Signal Spans and Common Mode Ranges

PGA Gain a_{IN}	Maximum Span V_{IN_SP} [mV/V] ¹⁾	Input Common Mode Range V_{IN_CM} [% VDDA] ²⁾	
		XZC = Off	XZC = On
420	1.8	29 to 65	45 to 55
280	2.7	29 to 65	45 to 55
210	3.6	29 to 65	45 to 55
140	5.4	29 to 65	45 to 55
105	7.1	29 to 65	45 to 55
70	10.7	29 to 65	45 to 55
52.5	14.3	29 to 65	45 to 55
35	21.4	29 to 65	45 to 55
26.3	28.5	29 to 65	45 to 55
14	53.75	29 to 65	45 to 55
9.3	80	29 to 65	45 to 55
7	107	29 to 65	45 to 55
2.8	267	32 to 57	Not applicable

1) Recommended maximum internal signal range is 75% of supply voltage.
Span is calculated by the following formula: $Span = 0.75 (VBR_T - VBR_B) / Gain$.

2) Refer to section 2.3.2 for an explanation of the extended analog zero compensation (XZC).

2.3.2. Offset Compensation

The ZSSC3138 processes a sensor-offset correction during the digital signal conditioning by the calibration microcontroller (CMC).

The ZSSC3138 also supports an extended analog zero compensation (XZC) for large offsets up to a maximum of approximately 300% of signal span, depending on the gain adjustment (Table 2.2). This prevents overdriving the analog signal path in the case of a large sensor offset by adding a compensation voltage to the second amplification stage.

Table 2.2 *Extended Analog Zero Compensation Ranges (XZC)*

PGA Gain a_{IN}	Maximum Span V_{IN_SP} [mV/V]	Offset Shift / XZC Step [% V_{IN_SP}]	Maximum Offset Shift [mV/V]	Maximum Shift (XZC = ± 31) [% V_{IN_SP}]
420	1.8	12.5 %	7.8	388%
280	2.7	7.6 %	7.1	237%
210	3.6	12.5 %	15.5	388%
140	5.4	7.6 %	14.2	237%
105	7.1	12.5 %	31	388%
70	10.7	7.6 %	28	237%
52.5	14.3	12.5 %	32	388%
35	21.4	7.6 %	57	237%
26.3	28.5	5.2 %	52	161%
14	53.75	12.5 %	194	388%
9.3	80	7.6 %	189	237%
7	107	5.2 %	161	161%
2.8	267	0.83 %	72	26%

2.3.3. Measurement Cycle

The measurement cycle is controlled by the CMC. Depending on EEPROM settings, the multiplexer (MUX) selects the following input signals in a defined sequence:

- Pre-amplified bridge sensor signal
- Temperature sensor signal
- Internal offset of the input channel (V_{OFF})

The cycle diagram in Figure 2.2 shows the basic structure of the measurement cycle. After power-on, the startup routine is processed, which performs all required measurements to expedite acquiring an initial valid conditioned sensor output. After the startup routine, the normal measurement cycle runs.

Figure 2.2 Measurement Cycle with 1 Bridge Sensor Signal Measurement per Special Measurement

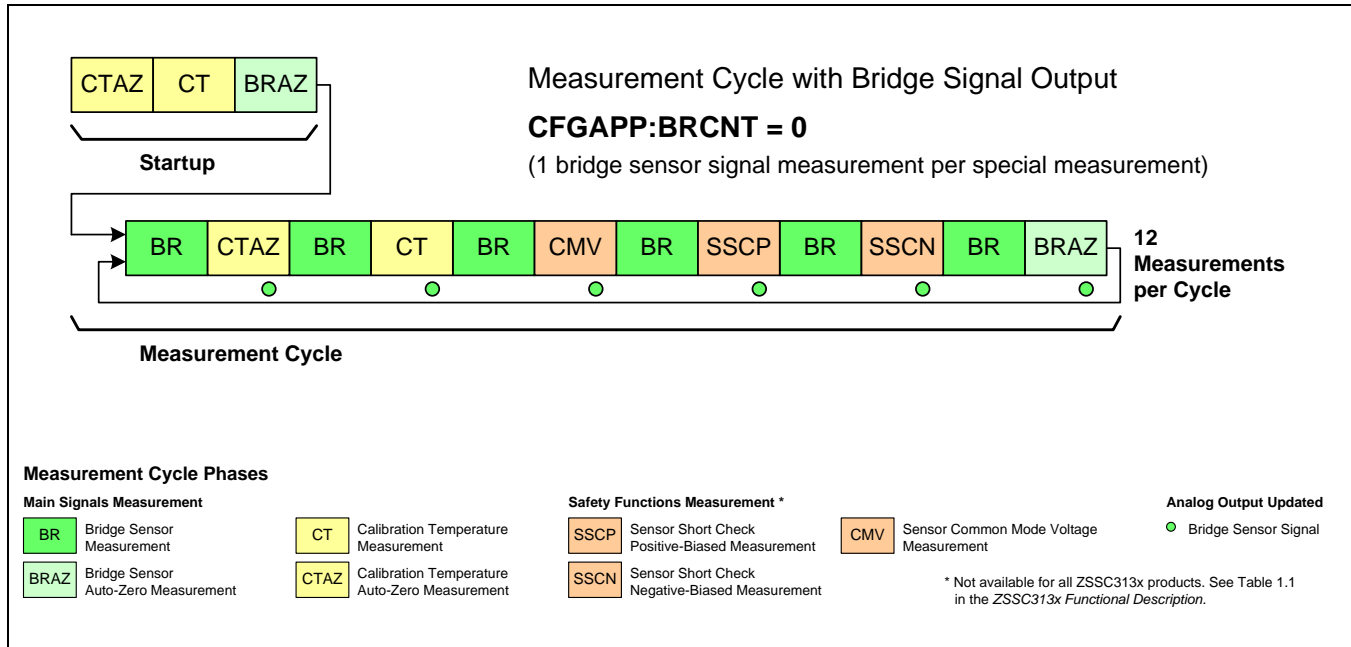

2.3.4. Analog-to-Digital Converter

The A/D converter is implemented using full-differential switched-capacitor technique.

- Programmable ADC resolutions are $r_{ADC} < 13, 14 >$ bit. The ZSSC3138 supports $< 15, 16 >$ bit resolution with range zooming.

The A/D conversion is integrating, inherently monotone, and insensitive to short and long term instability of the clock frequency. The conversion time t_{ADC} depends on the desired resolution and can be roughly calculated by equation (1):

$$t_{ADC} = \frac{2^{r_{ADC}}}{\left(\frac{f_{OSC}}{2}\right)} \tag{1}$$

Where

- r_{ADC} Resolution of A/D conversion
- f_{OSC} Frequency of internal oscillator (refer to 1.3.1)

The ZSSC3138 supports a high sample rate ADC mode (2-step conversion) with the advantage of a much shorter conversion time but with the drawback of a lower noise immunity caused by the shorter signal integration time. The conversion time $t_{\text{ADC},2\text{-step}}$ in this mode is roughly calculated by equation (2):

$$t_{\text{ADC},2\text{-step}} = \frac{2^{(r_{\text{ADC}}+3)/2}}{\left(\frac{f_{\text{OSC}}}{2}\right)} \quad (2)$$

Refer to the *ZSSC313x Bandwidth Calculation Sheet* for a detailed calculation of sampling time and bandwidth.

The result of the A/D conversion is a relative counter result Z corresponding to the following equation:

$$Z = 2^{r_{\text{ADC}}} \cdot \left(\frac{V_{\text{ADC_DIFF}}}{V_{\text{ADC_REF}}} - \text{RS}\right) \quad (3)$$

Where

r_{ADC}	Resolution of A/D conversion
$V_{\text{ADC_DIFF}}$	Differential ADC input voltage
$V_{\text{ADC_REF}}$	ADC reference voltage ($V_{\text{VBR_T}}-V_{\text{VBR_B}}$ or $V_{\text{VDDA}}-V_{\text{VSSA}}$, if $\text{BRREF}=1$)
RS	Digital ADC Range Shift (RS = 1/16, 1/8, 1/4, 1/2; controlled by the EEPROM contents)

With the RS value, a sensor input signal can be shifted in the optimal input range of the ADC.

The condition required for ensuring the specified accuracy, stability, and non-linearity parameters of the analog front-end is that the differential ADC input voltage $V_{\text{ADC_DIFF}}$ does not exceed the range of 10% to 90% of the ADC reference voltage $V_{\text{ADC_REF}}$. This requirement must be met for the whole temperature range and for all sensor tolerances.

Table 2.3 ADC Resolution versus Output Resolution and Sample Rate

ADC Adjustment		Output Resolution ¹⁾		Sample Rate ²⁾		Averaged Bandwidth ²⁾	
ADC Sample Rate Mode	r _{ADC} [bit]	Digital [bit]	Analog [bit]	f _{osc} =3MHz [Hz]	f _{osc} =4MHz [Hz]	f _{osc} =3MHz [Hz]	f _{osc} =4MHz [Hz]
Normal	13	13	12	345	460	130	172
	14	14	12	178	237	67	89
	15	14	12	90	120	34	45
	16	14	12	45	61	17	23
High	13	13	12	5859	7813	2203	2937
	14	14	12	3906	5208	1469	1958
	15	14	12	2930	3906	1101	1468
	16	14	12	1953	2604	734	979

1) Output resolution does not exceed ADC resolution. PGA gain should be such that the differential ADC input signal uses at least 50% of ADC input range to ensure maximum achievable output resolution.

2) Refer to the ZSSC313x *Bandwidth Calculation Sheet* for a detailed calculation of sampling time and bandwidth.

2.4. Temperature Measurement

The ZSSC3138 supports acquiring temperature data needed for conditioning of the sensor signal using an internal pn-junction temperature sensor.

Refer to the ZSSC313x *Functional Description* for a detailed explanation of temperature sensor adaptation and adjustment.

2.5. System Control and Conditioning Calculation

The system control supports the following tasks/features:

- Managing the startup sequence
- Controlling the measurement cycle regarding to the EEPROM-stored configuration data
- Sensor signal conditioning (calculation of the 16-bit correction for each measurement signal using the EEPROM-stored conditioning coefficients and the ROM-based formulas)
- Processing communication requests received via the digital interfaces
- Performing failsafe tasks and message detected errors by setting diagnostic states

2.5.1. General Working Modes

ZSSC3138 supports three different working modes:

- Normal Operation Mode (NOM) – for continuous processing of signal conditioning
- Command Mode (CM) – for calibration and access to all internal registers
- Diagnostic Mode (DM) – for failure messages

2.5.2. Startup Phase ¹

After power-on, the startup phase is processed, which includes

- Internal supply voltage settling including reset of the circuitry by the power-on reset block (POR). Refer to the *ZSSC313x High Voltage Protection Description* for power-on/off thresholds. Duration (beginning with $V_{VDDA}-V_{VSSA}=0V$): 500 μ s to 2ms; AOUT: high impedance.
- System start and configuration, EEPROM readout, and signature check. Duration: ~200 μ s; AOUT: lower diagnostic range (LDR).
- Processing the measurement cycle start routine. Duration: 5x A/D conversion time; AOUT behavior depends on configured one-wire communication mode (refer to section 2.6):
 OWIANA or OWIDIS \rightarrow AOUT: lower diagnostic range (LDR)
 OWIWIN or OWIENA \rightarrow AOUT: tri-state

If an error is detected during the startup phase, the Diagnostic Mode (DM) is activated and the analog output at the AOUT pin remains in the lower diagnostic range.

After the startup phase, the continuous running measurement and sensor signal conditioning cycle is started, and analog or digital output of the conditioned sensor signal is activated. If the one-wire communication mode OWIWIN is selected, the OWI startup window expires before analog output is available.

2.5.3. Conditioning Calculation

The digitalized value for the bridge signal is processed with a conditioning formula to remove offset and temperature dependency and to compensate nonlinearity up to 3rd order. The result is a non-negative 15-bit value for the measured bridge sensor signal in the range [0; 1). This value is available for readout via I²C or OWI communication. For the analog output, the value is clipped to the programmed output limits.

Note: The extent of signal deviation that can be compensated by the conditioning calculation depends on the specific sensor signal characteristics. For a rough estimation, assume the following: offset compensation and gain correction are not limited. Notice that resolution of the digitally gained signal is determined by the ADC resolution in respect to the dynamic input range used. The temperature correction includes first and second order terms and should be adequate for all practically relevant cases. The non-linearity correction of the sensor signal is possible for second-order up to about 30% FS regarding ideal fit and for third-order up to about 20% FS. Overall, the conditioning formula applied is able to reduce the non-linearity of the sensor signal by a factor of 10.

¹ All timing values are roughly estimated for an oscillator frequency $f_{osc}=3MHz$ and are proportional to that frequency.

2.6. Analog or Digital Output

The AOUT pin is used for analog output and for one-wire communication (OWI). The latter can be used for digital readout of the conditioned sensor signal and for end-of-line sensor module calibration. The ZSSC3138 supports different modes for the analog output in interaction with OWI communication:

- OWIENA: Analog output is deactivated; OWI readout of the signal data is enabled.
- OWIWIN: Analog output starts after the startup phase and after the OWI startup window if OWI communication is not initiated; OWI communication for configuration or for end-of-line calibration can be started during the OWI startup window (maximum ~500ms) by sending the START_CM command.
- OWIANA: Analog output starts after the startup phase; OWI communication for configuration or for end-of-line calibration can be started during the OWI startup window (maximum ~500ms) by sending the START_CM command; for command transmission, the driven analog output at the AOUT pin must be overwritten by the external communication master (AOUT drive capability is current-limited).
- OWIDIS: Analog output starts after the startup phase; OWI readout of the signal data is disabled.

The analog output signal is driven by an offset compensated, rail-to-rail output buffer that is current-limited to prevent damage to the ZSSC3138 from a short circuit between the analog output and power supply or ground. Output resolution of at least 12-bit in the range of 10% to 90% FS is ensured by a 12.4-bit resistor string DAC.

2.7. Serial Digital Interface

The ZSSC3138 includes a serial digital I²C™ interface and a ZACwire™ interface for one-wire communication (OWI). The digital interfaces allow configuration and calibration of the sensor module. OWI communication can be used to perform an end-of-line calibration via the analog output pin AOUT of a completely assembled sensor module. The interfaces also provide the readout of the conditioned sensor signal data during normal operation.

Refer to the *ZSSC313x Functional Description* for a detailed description of the serial interfaces and the communication protocols.

2.8. Failsafe Features

The ZSSC3138 detects various failures. When a failure is detected, Diagnostic Mode (DM) is activated. DM is indicated by setting the output pin AOUT to the Lower Diagnostic Range (LDR). When using digital serial communication protocols (I²C™ or OWI) to read conditioning results data, the error status is indicated by a specific error code.

A watchdog timer controls the proper operation of the microcontroller. The operation of the internal oscillator is monitored by an oscillator-failure detection circuit. EEPROM and RAM content are checked when accessed. Control registers are parity protected.

The sensor connection is checked with regard to broken wires or short circuits (sensor connection check, sensor short check).

Refer to the *ZSSC313x Functional Description* for a detailed description of failsafe features and methods of error indication.

2.9. High Voltage, Reverse Polarity, and Short Circuit Protection

The ZSSC3138 is designed for 5V power supply operation.

The ZSSC3138 and the connected sensor are protected from overvoltage and reverse polarity damage by an internal supply voltage limiter. The analog output AOUT can be connected (short circuit, overvoltage, and reverse polarity) with all potentials in the protection range under all potential conditions at the pins VDDE and VSSE.

To guarantee this operation, all external components (see application circuit in section 3) are required. The protection is not time-limited.

Refer to the *ZSSC313x High Voltage Protection Description* for a detailed description of protection cases and conditions.

3 Application Circuit Examples

The application circuits contain external components that are needed for overvoltage, reverse polarity, and short circuit protection.

Note: Also check the ZSSC313x application notes for application examples and board layout.

Table 3.1 External Components for Application Circuit Examples

Symbol	Component	Min	Typ ²⁾	Max	Unit	Remarks
C1	Capacitor	100		470	nF	
C2	Capacitor	100			nF	
C3 ¹⁾	Capacitor	4	47	160	nF	Value includes the load capacitor C3 and the capacitance of the connection cable.
C4, C5 ¹⁾	Capacitor	0		10	nF	Recommended to increase EMI immunity. Value includes the filter capacitor C4 and C5 and the sensor connection line capacitance.

1) Increasing capacitors C3, C4, and C5 increases EMI immunity.
 2) Dimensioning is only for example and must be adapted to the requirements of the application.

Figure 3.1 Application with On-Chip Diode Temperature Sensor

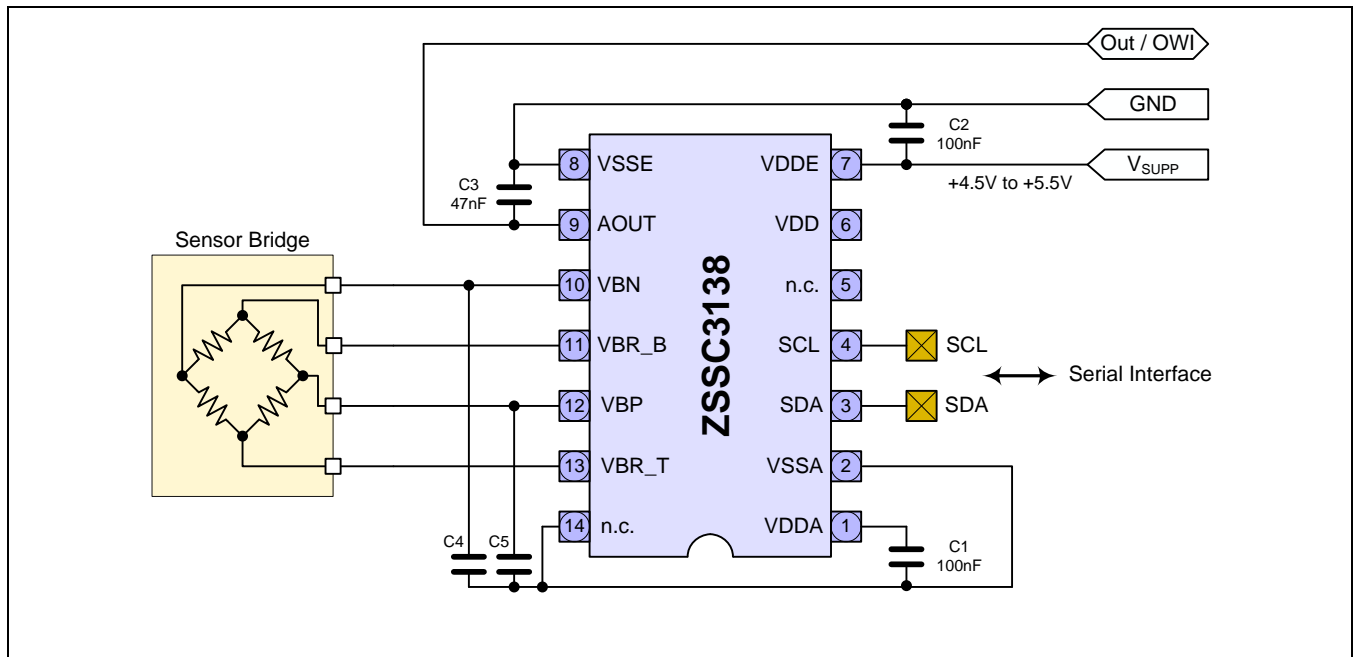

4 Pin Configuration and Package

Table 4.1 Pin Configuration and Definition

Pin No	Pin Name	Description	Remarks
1	VDDA	Positive Analog Supply Voltage	Internal analog supply
2	VSSA	Negative Analog Supply Voltage	Internal analog ground
3	SDA	I ² C™ Serial Data	Digital I/O; internal pull-up to VDDA
4	SCL	I ² C™ Clock	Digital input; internal pull-up to VDDA
5	N.C.	Not connected	
6	VDD	Positive Digital Supply Voltage	Internal digital supply
7	VDDE	Positive External Supply Voltage	High voltage analog supply
8	VSSE	Negative External Supply Voltage	Ground
9	AOUT	Analog Output and ZACwire™ Serial Data	High voltage analog I/O
10	VCN	Negative Input from Sensor Bridge	Analog input
11	VBR_B	Negative Sensor Bridge Supply Voltage	Analog I/O Depending on application circuit, short to VSSA
12	VBP	Positive Input from Sensor Bridge	Analog input
13	VBR_T	Positive Sensor Bridge Supply Voltage	Analog I/O Depending on application circuit, short to VDDA
14	N.C.	Not connected	

The standard package of the ZSSC3138 is an RoHS-compliant SSOP14 “green” package (5.3mm body width) with a lead pitch of 0.65 mm.

Figure 4.1 ZSSC3138 SSOP14 Pin Diagram

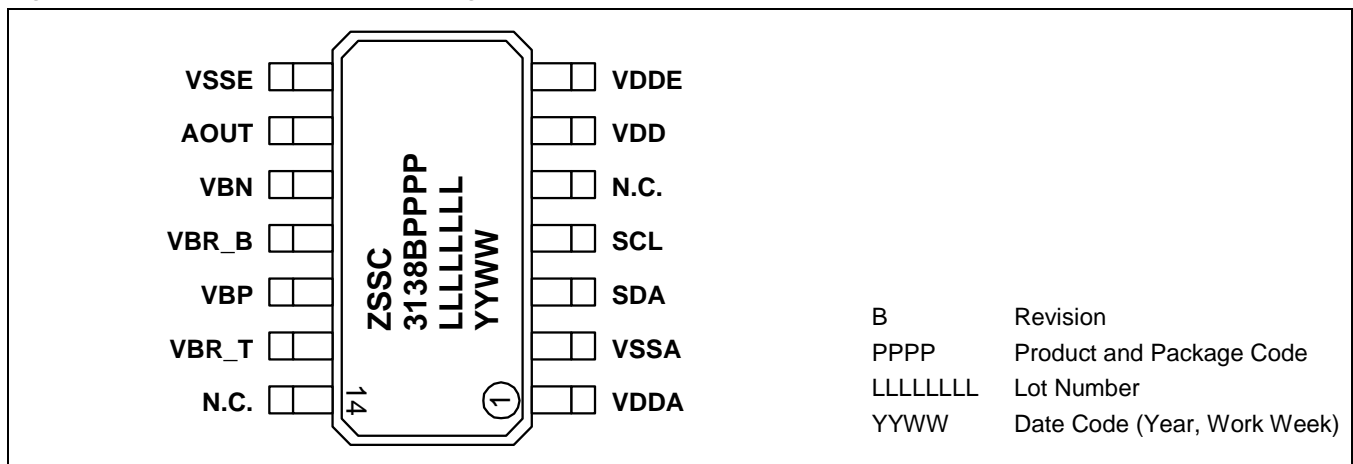

5 ESD Protection

All pins have an ESD protection of >2000V according to the Human Body Model (HBM). The pins VDDE, VSSE and AOUT have an additional ESD protection of >4000V (HBM).

ESD protection is tested with devices in SSOP14 packages during product qualification. The ESD test follows the Human Body Model with 1.5kOhm/100pF based on MIL 883, Method 3015.7.

6 Quality and Reliability

The ZSSC3138 is qualified according to the AEC-Q100 standard, operating temperature grade 0.

A fit rate <5fit (T=55°C, S=60%) is guaranteed. A typical fit rate of the semiconductor technology used is 2.5fit.

7 Customization

For high-volume applications that require an upgraded or downgraded functionality compared to the ZSSC3138, IDT can customize the circuit design by adding or removing certain functional blocks.

Please contact IDT for further information.

8 Ordering Information

Product Sales Code	Description	Package
ZSSC3138BA2T	ZSSC3138 SSOP14 – temperature range -40 to +125°C	Tube
ZSSC3138BA2R	ZSSC3138 SSOP14 – temperature range -40 to +125°C	Reel
ZSSC3138BA1B	ZSSC3138 die – temperature range -40 to +125°C	Tested dice on unsawn wafer
ZSSC3138BA1C	ZSSC3138 die – temperature range -40 to +125°C	Tested dice on frame
ZSSC3138BE2T	ZSSC3138 SSOP14 – temperature range -40 to +150°C	Tube
ZSSC3138BE2R	ZSSC3138 SSOP14 – temperature range -40 to +150°C	Reel
ZSSC3138BE1B	ZSSC3138 die – temperature range -40 to +150°C	Tested dice on unsawn wafer
ZSSC3138BE1C	ZSSC3138 die – temperature range -40 to +150°C	Tested dice on frame
ZSSC313xKITV1.1	ZSSC313x Evaluation Kit, revision 1.1, including Evaluation Board, ZSSC3138 IC samples, USB cable	Kit
ZSSC313x Mass Calibration System V1.1	Modular Mass Calibration System (MSC) for ZSSC313x including MCS boards, cable, connectors	Kit

9 Related Documents

Document
<i>ZSSC3135 Feature Sheet</i>
<i>ZSSC313x Functional Description</i>
<i>ZSSC313x Evaluation Kit Description</i>
<i>ZSSC313x Technical Note—EMC Design Guidelines*</i>
<i>ZSSC313x Technical Note—High Voltage Protection*</i>
<i>ZSSC313x Technical Note Die & Package Dimensions**</i>
<i>ZSSC313x Temperature Profile Calculation Spread Sheet</i>
<i>ZSSC313x Bandwidth Calculation Spread Sheet**</i>

Visit the ZSSC3138 product page (www.IDT.com/ZSSC3138) or contact your nearest sales office for the latest version of these documents.

* Documents marked with an asterisk (*) require a login account for access on the web.

** Documents marked with a double asterisk (**) are available only on request.

10 Glossary

Term	Description
ADC	Analog-to-Digital Converter
AEC	Automotive Electronics Council
AFE	Analog Front-end
AOUT	Analog Output
BAMP	Buffer Amplifier
BR	Bridge Sensor Signal
CM	Command Mode
CMC	Calibration Microcontroller
CMOS	Complementary Metal Oxide Semiconductor
DAC	Digital-to-Analog Converter
DM	Diagnostic Mode
EEPROM	Electrically Erasable Programmable Read-Only Memory
ESD	Electrostatic Device
LDR	Lower Diagnostic Range
MUX	Multiplexer
NOM	Normal Operation Mode
OWI	One-Wire Communication
PGA	Programmable Gain Amplifier
POR	Power-on Reset
RAM	Random-Access Memory
RISC	Reduced Instruction Set Computer
ROM	Read-Only Memory
SCC	Sensor Connection Check
SSC	Sensor Signal Conditioner or Sensor Short Check depending on context.
T	Temperature Sensor Signal
TS	Temperature Sensor
XZC	eXtended Zero Compensation

11 Document Revision History

Revision	Date	Description
1.00	October 18, 2011	First released revision.
1.10	January 20, 2012	Full revision.
1.20	September 25, 2012	Minor edits. Update for IDT contact information.
1.21	February 15, 2013	Updates to specifications 1.3.7.1, 1.3.7.2, and 1.3.7.3. Addition of RS factor (ADC Range Shift) to equation (2). Minor edits. Update for ZMD America contact information.
1.22	October 22, 2013	Updates for contact information and imagery for cover and headers. Updates for related documents. Update for available part codes and kit contents listed in ordering tables.
1.23	April 21, 2014	Corrections for part ordering table on page 3. Update for cover imagery. Update for contact information.
1.24	April 10, 2015	Update for contact info.
	January 25, 2016	Changed to IDT branding.



Corporate Headquarters
6024 Silver Creek Valley Road
San Jose, CA 95138
www.IDT.com

Sales
1-800-345-7015 or 408-284-8200
Fax: 408-284-2775
www.IDT.com/go/sales

Tech Support
www.IDT.com/go/support

DISCLAIMER Integrated Device Technology, Inc. (IDT) reserves the right to modify the products and/or specifications described herein at any time, without notice, at IDT's sole discretion. Performance specifications and operating parameters of the described products are determined in an independent state and are not guaranteed to perform the same way when installed in customer products. The information contained herein is provided without representation or warranty of any kind, whether express or implied, including, but not limited to, the suitability of IDT's products for any particular purpose, an implied warranty of merchantability, or non-infringement of the intellectual property rights of others. This document is presented only as a guide and does not convey any license under intellectual property rights of IDT or any third parties.

IDT's products are not intended for use in applications involving extreme environmental conditions or in life support systems or similar devices where the failure or malfunction of an IDT product can be reasonably expected to significantly affect the health or safety of users. Anyone using an IDT product in such a manner does so at their own risk, absent an express, written agreement by IDT.

Integrated Device Technology, IDT and the IDT logo are trademarks or registered trademarks of IDT and its subsidiaries in the United States and other countries. Other trademarks used herein are the property of IDT or their respective third party owners. For datasheet type definitions and a glossary of common terms, visit www.idt.com/go/glossary. All contents of this document are copyright of Integrated Device Technology, Inc. All rights reserved.