

1. GENERAL DESCRIPTION

The W567Jxxx is a powerful microcontroller (uC) dedicated to speech and melody synthesis applications. With the help of the embedded 8-bit microprocessor & dedicated H/W, the W567Jxxx can synthesize 6-channel speech+melody simultaneously.

The two channels of synthesized speech can be in different kinds of format, for example ADPCM and MDPCM. The W567Jxxx can provide 6-channel high-quality *WinMelody™*, which can emulate the characteristics of musical instruments, such as piano and violin. The output of speech/melody channels are mixed together through the on-chip digital mixer to produce colorful effects. With these hardware resources, the W567Jxxx is very suitable for high-quality and sophisticated scenario applications.

The W567Jxxx provides at most 24 bi-directional I/Os, 256 bytes RAM, IR carrier, Serial Interface Management and more sophisticated applications, such as interactive toys, cartridge toys and final count down function. 3 LED output pins with 256-level control means that numerous combination of RGB colors may result in a versatility of colorful effects. In addition, W567Jxxx also provides PWM mode output to save power during playback and Watch Dog Timer to prevent latch-up situation occurring.

The W567Jxxx family contains several items with different playback duration as shown below.

Item	W567J070	W567J080	W567J100	W567J120	W567J151	W567J171
*Duration	81 sec.	102 sec.	115 sec.	127 sec.	162 sec.	196 sec.
Item	W567J210	W567J260	W567J300	W567J340	W567J380	
Duration	230 sec.	263 sec.	320 sec.	358 sec.	400 sec.	

Note:

*: The duration time is based on 5-bit MDPCM at 6 KHz sampling rate. The firmware library and timber library have been excluded from user's ROM space for the duration estimation.

2. FEATURES

- Wide range of operating voltage:
 - 8 MHz @ 3.0 volt ~ 5.5 volt
 - 6 MHz @ 2.4 volt ~ 5.5 volt
- Power management:
 - 4 ~ 8 MHz system clocks, with Ring type or crystal type.
 - Stop mode for stopping all IC operations
- Provides up to 24 I/O pins
 - W567J070~J120: 16 I/O
 - W567J151~J380: 24 I/O
- F/W speech synthesis:
 - Multiple format parser that supports
 - ✓ 6-bit MDPCM, 5-bit MDPCM, 4-bit MDPCM, 4-bit ADPCM, 8-bit Log PCM algorithm can be used
 - Pitch shippable ADPCM for voice changer application
 - Programmable sample rate
- Melody synthesis:
 - 6 melody channels that can emulate characteristics of musical instruments
 - More MIDI events are supported for colorful melody playback
- Built-in TimerG0 for general purpose applications
- Harmonized synchronization among MIDI, Speech, LED, and Motor
- Build-in 3 LED outputs with 256-level control of brightness.
- Built-in Watch-Dog Timer (WDT) and Low Voltage Reset (LVR)
- Provide serial interface to access the external memory in W567J070~J380
 - W55Fxx, W551Cxx
 - SPI flash
- Built-in IR carrier generation circuit for simplifying firmware IR application
- Current type digital-to-analog converters (DAC) with 13-bit resolution to drive speaker output
- Direct-drive 12-bit PWM output to save power consumption
- Support **PowerScript™** for developing codes in easy way
- Full-fledged development system
 - Source-level ICE debugger (Assembly & **PowerScript™** format)
 - **Ultra I/O™** tool for event synchronization mechanism
 - ICE system with USB port
 - User-friendly GUI environment
- Available package form:
 - COB is essential

3. PIN DESCRIPTION

PIN NAME	I/O	FUNCTION
/RESET	I	IC reset input, low active.
OSCIN	I	Main-clock oscillation input. When Ring type is used, connects Rosc between OSCIN and VSS to generate the system clock frequency. Reserved one 100pF~200pF capacity to VDD from OSCin pin to make Ring frequency stability When use X'tal, it is X'tal IN.
OSCOU	O	Main-clock oscillation output only for X'tal.
BP00~BP07	I/O	General input/output pins. When used as output pin, it can be open-drain or CMOS type and it can sink 25mA for high-current applications. When used as input pin, there may have a pull-high option and generate interrupt request to release IC from STOP mode. BP04~BP06 are used as 3 LED outputs with 256-level control.
BP10~BP17	I/O	General input/output pins. When used as output pin, it can be open-drain or CMOS type. When used as input pin, there may have a pull-high option and generate interrupt request to release IC from STOP mode.
BP20~BP27 ¹	I/O	General input/output pins. When used as output pin, it can be open-drain or CMOS type. When used as input pin, there may have a pull-high option and generate interrupt request to release IC from STOP mode.
PWM+/DAC	O	PWM driver positive output or Current type DAC output
PWM-	O	PWM driver negative output
TEST	I	Test input, internally pulled high. Do not connect during normal operation.
VDD	Power	Positive power supply for uP and peripherals. All VDD pins must be bonded out and connect to VDD
VDD1	Power	Only W567J151/171 for Positive power supply for uP and peripherals. It needs be bonded out and connect to VDD.
VSS	Power	Negative power supply for oscillation, uP and peripherals.
VDDOSC	Power	Positive power supply for oscillation.
VDDSPK	Power	Positive power supply for speaker driver.
VSSSPK	Power	Negative power supply for speaker driver.
CVDD	O	For 3 battery(3.3V~5.5V) application, the capacitor, 0.1uF, shunts between CVDD and GND as power stability for regulator output. For 2 battery(2.2V~3.6V) application, CVDD will connect to VDD directly. Note: W567J151/171 without CVDD pin, the application circuit don't need consider 3/2battery application.
VDD_BP1	Power	Positive power supply for BP1 including serial interface Management (SIM).

¹ BP2 isn't provided in W567J070 ~ W567J120.

4. BLOCK DIAGRAM

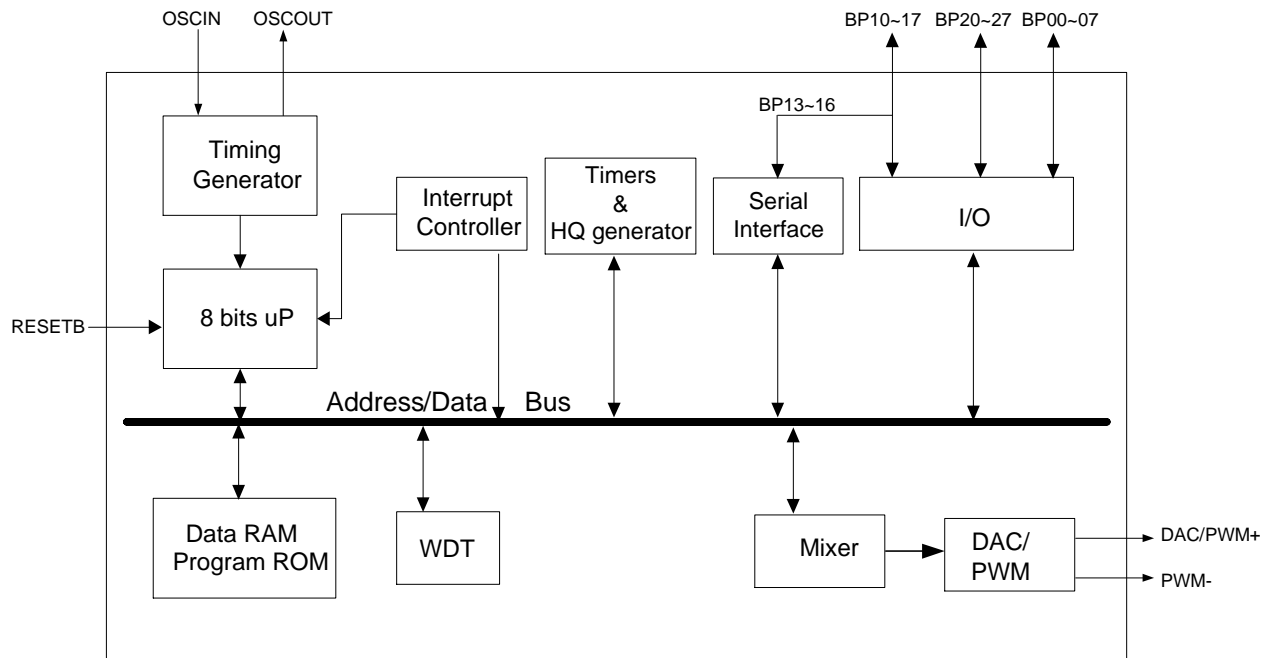

Notes:

1. BP2 isn't provided in W567J070 ~ W567J120.

5. ITEM VS PIN TABLE

PIN name	J070/ 080/ 100/ 120	J151/ 171	J210/ 260/ 300/ 340/ 380	Comment
BP00~BP07	V	V	V	
BP10~BP17	V	V	V	
BP20~BP27	-	V	V	
/RESET	V	V	V	
TEST	V	V	V	
PWM+/DAC	V	V	V	
PWM-	V	V	V	
OSCIN	V	V	V	
OSCOU	V	V	V	Crystal mode
VDD	V	V	V	
VSS	V	V	V	
VDDSPK	V	V	V	Support speaker power
VSSSPK	V	V	V	
VDD_BP1	V	V	V	Support BP10~BP17 including SIM interface power
VDDOSC	V	V	V	Support OSCIN/OUT power
VSSOSC	V	V	V	
CVDD	V	-	V	Regulator out
VDD1		V		Connect to VDD

6. ELECTRICAL CHARACTERISTICS

6.1 Absolute Maximum Ratings

PARAMETER	RATING	UNIT
Supply Voltage to Ground Potential	-0.3 to +7.0	V
D.C. Voltage on Any Pin to Ground Potential	-0.3 to $V_{DD} + 0.3$	V
Operating Temperature	0 to +70	°C
Storage Temperature	-55 to +150	°C

Note: Exposure to conditions beyond those listed under Absolute Maximum Ratings may adversely affect the life and reliability of the device.

6.2 DC Characteristics

($V_{DD} - V_{SS} = 4.5$ V, $F_M = 8$ MHz, $T_a = 25^\circ\text{C}$, No Load unless otherwise specified)

PARAMETER	SYM.	TEST CONDITIONS	SPEC.			UNIT
			Min.	Typ.	Max.	
Operating Voltage	V_{DD}	$F_{SYS} = 6$ MHz	2.4	-	5.5	V
		$F_{SYS} = 8$ MHz	3.0	-	5.5	V
Operating Current	I_{OP1}	No load, $F_{SYS} = 6$ MHz	-	6	10	mA
Standby Current	I_{SB}	STOP mode	-	1	2	μA
Input Low Voltage	V_{IL}	All input pins	V_{SS}	-	$0.3 V_{DD}$	V
Input High Voltage	V_{IH}	All input pins	$0.7 V_{DD}$	-	V_{DD}	V
Input Current (BP0, BP1, BP2)	I_{IN1}	$V_{IN} = 0$ V, pulled-high resistor = 500k ohm	-5	-9	-14	μA
Input Current (BP0, BP1, BP2)	I_{IN2}	$V_{IN} = 0$ V, pulled-high resistor = 150k ohm	-15	-30	-45	μA
Output Current (BP0)	I_{OL}	$V_{DD} = 3$ V, $V_{OUT} = 0.4$ V	8	12	-	mA
	I_{OH}	$V_{DD} = 3$ V, $V_{OUT} = 2.6$ V	-4	-6	-	mA
	I_{OL}	$V_{DD} = 4.5$ V, $V_{OUT} = 1.0$ V	-	25	-	mA
	I_{OH}	$V_{DD} = 4.5$ V, $V_{OUT} = 3.5$ V	-	-12	-	mA
Output Current (BP1, BP2)	I_{OL}	$V_{DD} = 3$ V, $V_{OUT} = 0.4$ V	4	8	-	mA
	I_{OH}	$V_{DD} = 3$ V, $V_{OUT} = 2.6$ V	-4	-6	-	mA
	I_{OL}	$V_{DD} = 4.5$ V, $V_{OUT} = 1.0$ V	-	12	-	mA
	I_{OH}	$V_{DD} = 4.5$ V, $V_{OUT} = 3.5$ V	-	-12	-	mA

PARAMETER	SYM.	TEST CONDITIONS	SPEC.			UNIT
			Min.	Typ.	Max.	
DAC Full Scale Current	I_{DAC}	$V_{DD} = 4.5V, R_L = 100\Omega$	-2.4 -4.0	-3.0 -5.0	-3.6 -6.0	mA
Output Current PWM+ / PWM-	I_{OL1}	$R_L = 8 \text{ Ohm},$ [PWM+]----[RL]----[PWM-]	+200	-	-	mA
	I_{OH1}		-200	-	-	mA
Pull-high Resistor Test	R_{PL}		75	150	225	K Ω

6.3 AC Characteristics

($V_{DD}-V_{SS} = 4.5 \text{ V}, F_M = 8 \text{ MHz}, T_a = 25^\circ\text{C};$ No Load unless otherwise specified)

PARAMETER	SYM.	TEST CONDITIONS	SPEC.			UNIT
			Min.	Typ.	Max.	
Main-Clock	F_M	Ring type, *Rosc = TBD Ω	5.4	6	6.6	MHz
		Ring type, *Rosc = TBD Ω	7.2	8	8.8	
Main-Clock Wake-up Stable Time	T_{WSM}	Ring type, R = TBD K Ω	-	3	5	mS
Main-Clock Frequency Deviation, Ring type	$\frac{\Delta F}{F}$	$\frac{F_{MAX} - F_{MIN}}{F_{MIN}}$	-	3	7.5	%
Cycle Time	T_{CYC}	CPU clock = 6 MHz	166	-	DC	nS
/RESET Active Width	T_{RES}	After F_{SYS} stable	4	-	-	T_{CYC}

*: Typical ROSC value for each part number should refer to design guide.

7. TYPICAL APPLICATION CIRCUIT

a. Rosc with 2 Battery

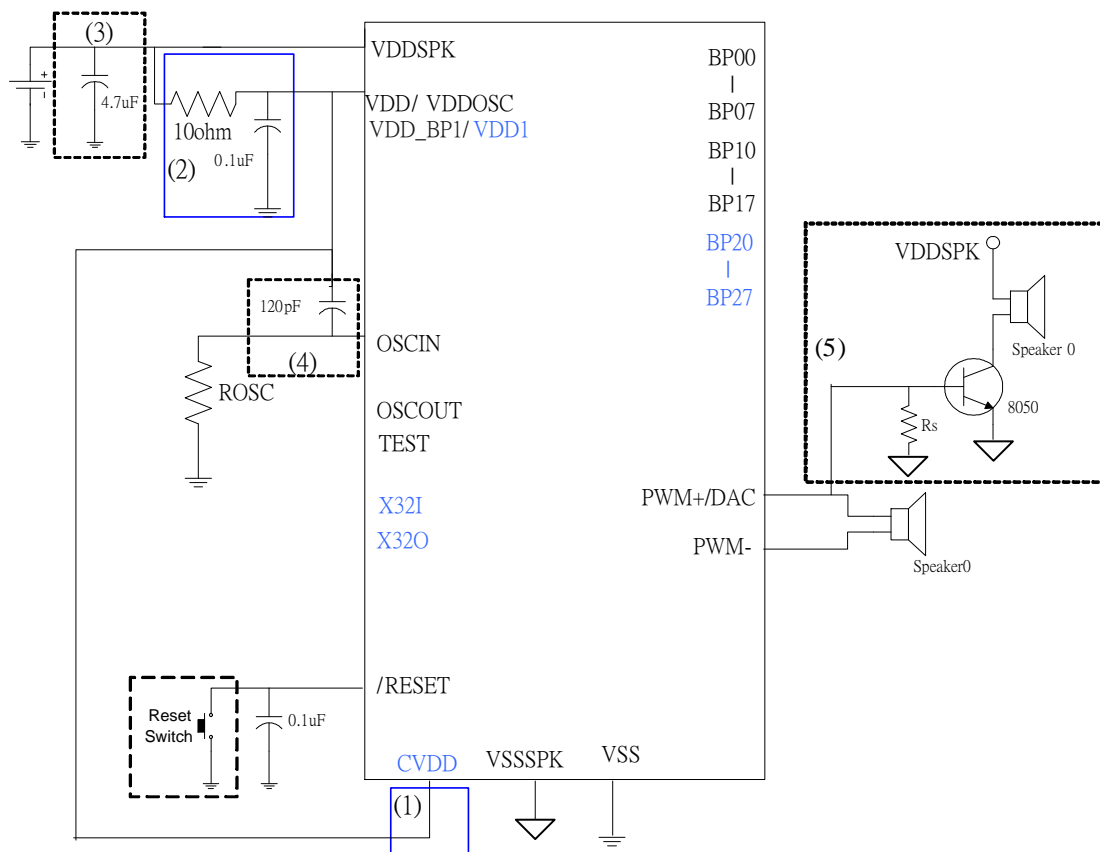

Notes:

1. The block (1): If the project is two-battery application (Voltage 3.6V~2.2V), it is necessary to connect CVDD to VDD.
2. The block (2): The low-pass filter circuit is necessary for VDD stability, in order to avoid VDDSPK noise.
3. The block (3): The capacitor, 4.7uF, shunted between VDD and GND is necessary for power stability. However, the value of capacitor depends on the power loading of the application.
4. The typical value of Rosc is 300 K Ω for 8MHz and 390 K Ω for 6MHz, and the Rosc should be connected to GND (VSS). Please refer to design guide to get typical Rosc value for each part number.
5. The block (4):The capacitor, 120pF, shunted between OSCIN and VDD is optional for Fosc stability, which can prevent noise from happening, because it can block the affection of larger current while playing. However, the value of capacitor depends on the application (100pF~200pF is recommended)
6. The block (5): The Rs value is suggested of 270 Ω ~ 1K Ω to limit large DAC output current flowing into transistor.
7. The above application circuit is for reference only. No warranty for mass production.

b. Rosc with 3 Battery

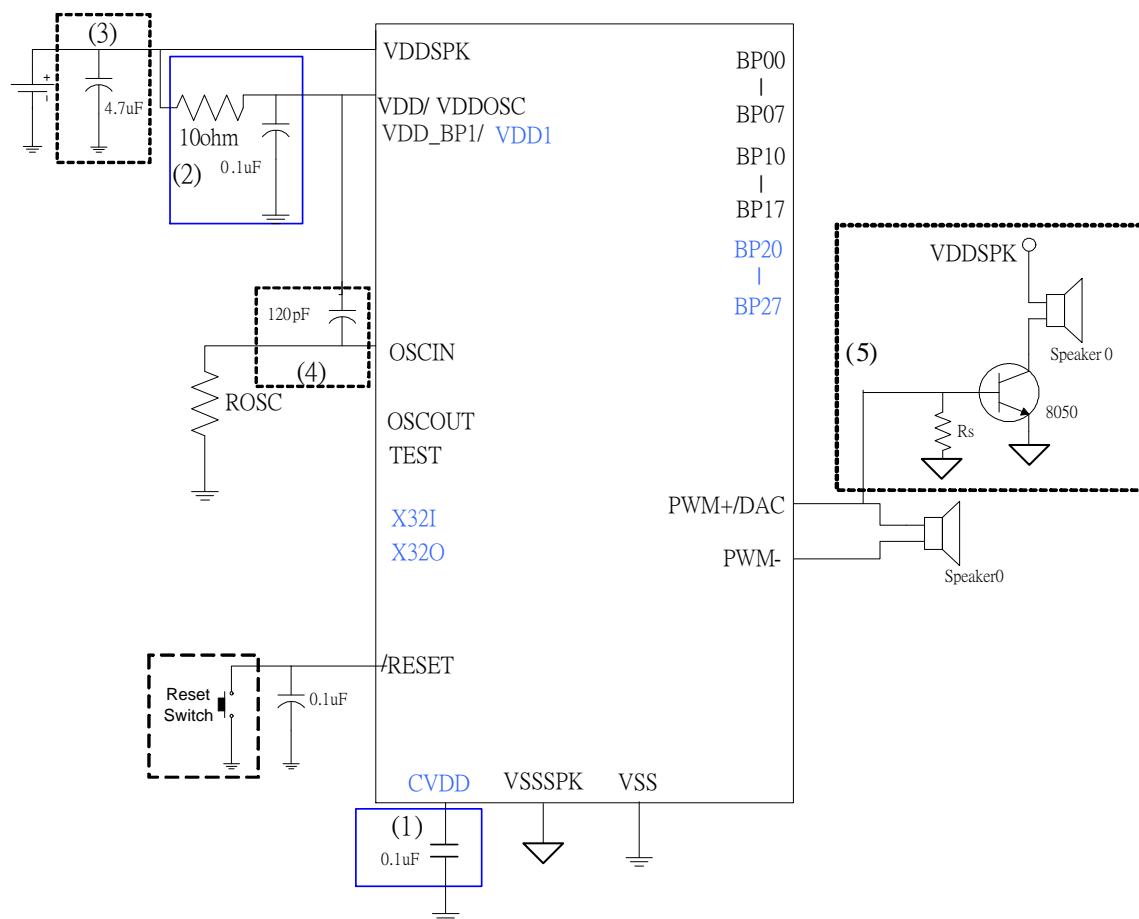

Notes:

1. The block (1): If the project is three-battery application (Voltage 5.5V~3.0V), it is necessary to connect a 0.1uF between CVDD and GND (VSS).
2. The block (2): The low-pass filter circuit is necessary for VDD stability, in order to avoid VDDSPK noise
3. The block (3): The capacitor, 4.7uF, shunted between VDD and GND is necessary for power stability. However, the value of capacitor depends on the power loading of the application.
4. The typical value of Rosc is 300 KΩ for 8MHz and 390 KΩ for 6MHz, and the Rosc should be connected to GND (VSS). Please refer to design guide to get typical Rosc value for each part number.
5. The block (4)The capacitor, 120pF, shunted between OSCIN and VDD is optional for Fosc, which can prevent noise from happening, because it can block the affection of larger current while playing. However, the value of capacitor depends on the application (100pF~200pF is recommended)
6. The block (5): The Rs value is suggested of 270Ω ~ 1KΩ to limit large DAC output current flowing into transistor.
7. The above application circuit is for reference only. No warranty for mass production.

c. Crystal

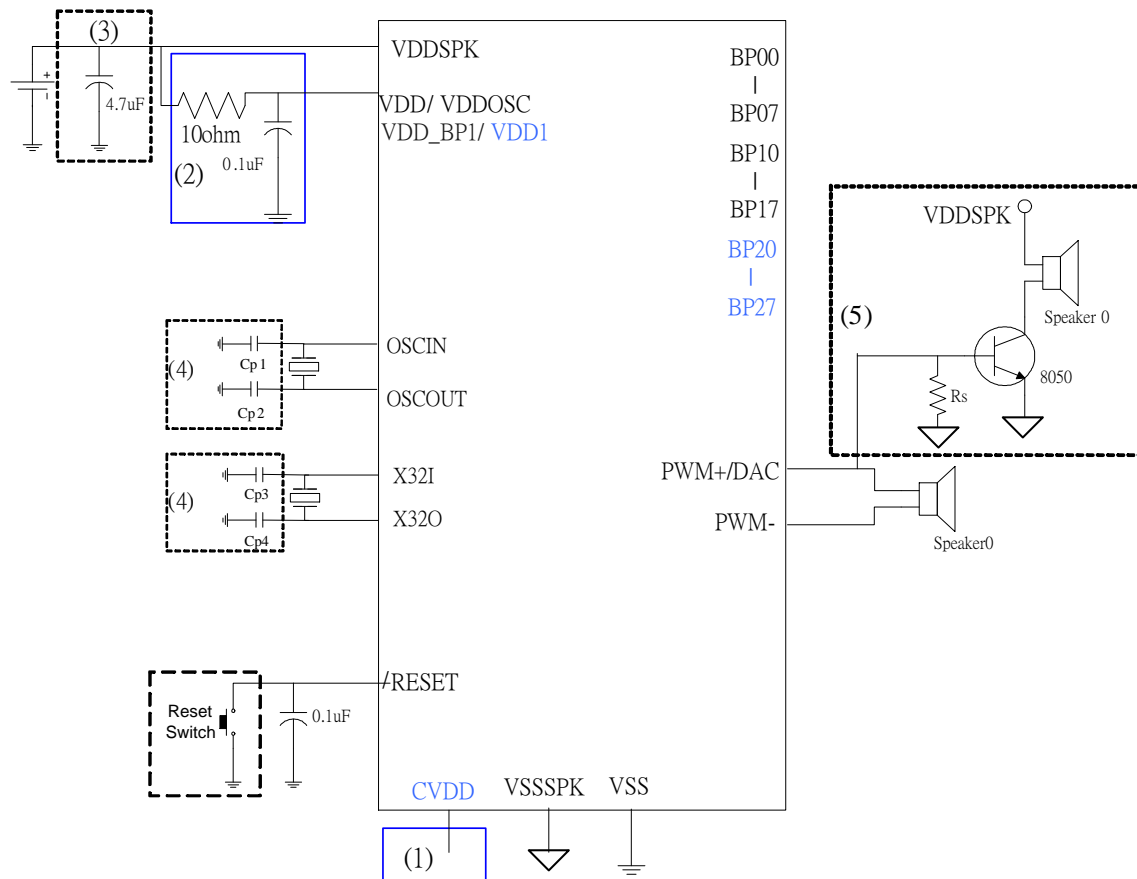

Notes:

1. The block (1): Please refer to (a) and (b) circuits for two-battery or three-battery application.
2. The block (2): The low-pass filter circuit is necessary for VDD stability, in order to avoid VDDSPK noise.
3. The block (3): The capacitor, 4.7uF, shunted between VDD and GND is necessary for power stability. However the value of capacitor depends on the power loading of the application
4. The block (4): Cp1 and Cp2 (15~30pF) are optional for main Crystal, which can be skipped normally.
5. The block (5): The Rs value is suggested of 270Ω ~ 1KΩ to limit large DAC output current flowing into transistor.
6. Cp3 and Cp4 (15~30pF) are optional for 32KHz Crystal, which can be skipped normally.
7. Please connect all VDD pins include VDDOSC/VDD_BP1 to VDD. If with SIM application, the VDD_BP1 pin can connect to different voltage for SPI flash or W551Cxx and the BP10~BP17 also use the same power VDD_BP1.
8. The above application circuit is for reference only. No warranty for mass production.
9. Other application circuits please refer to Design Guide.

d. PCB layout guide

1. The IC substrate should be connected to VSS in PCB layout, but VSSSPK can't connect with IC substrate directly. Both VSS and VSSSPK tie together in battery negative power.
2. Each VDD, VDDOSC, VDD_BP1, VDD1 and VDDSPK pad must connect to positive power to support stable voltage for individual function work successfully. (Don't let them be floating.)

8. REVISION HISTORY

VERSION	DATE	REASONS FOR CHANGE	PAGE
A0.0	Jan 2007	Preliminary release.	
A1.0	May 2007	<ul style="list-style-type: none"> ● Add SIM function ● Remove 32K Crystal current on DC characteristics ● Modify application circuit 	
A2.0	Nov 2007	<ul style="list-style-type: none"> ● Remove multi-midi function ● Modify application circuit and naming ● Modify Logo 	
A3.0	Sep. 2008	<ul style="list-style-type: none"> ● Change logo 	
A4.0	Jun. 2009	<ul style="list-style-type: none"> ● Modify application circuit 	
A5.0	May. 2010	<ul style="list-style-type: none"> ● Add 2 battery application circuit 	
A6.0	Dec, 2010	<ul style="list-style-type: none"> ● Update output current for BP1/2 @4.5V/3.0V and update BP0 @4.5V ● Add application circuit for Ring OSCin pin to add 120pF to VDD ● Modify the description for application circuit ● Support MD4 format for F/W library 	6 8~15 8~15 3
A7.0	July. 2011	<ul style="list-style-type: none"> ● Add new chip W567J151/171 	
A8.0	Aug. 2011	<ul style="list-style-type: none"> ● Remove W567J160/170. ● Add new chip W567J151/171 pad description ● Add new chip W567J151/171 application circuit ● Add SIM application circuit 	2, 5 9~18 18
A9.0	Feb. 2012	<ul style="list-style-type: none"> ● Add W567CP80 OTP chip ● Add items vs pad table ● Modify application circuits 	2 7
A10.0	Mar. 2012	<ul style="list-style-type: none"> ● BP00~BP03 share pins as OTP writer in W567CP80. ● Correct TEST pin as internal pull high ● Update operating current DC spec. 	4 4 9

Important Notice

Nuvoton Products are neither intended nor warranted for usage in systems or equipment, any malfunction or failure of which may cause loss of human life, bodily injury or severe property damage. Such applications are deemed, "Insecure Usage".

Insecure usage includes, but is not limited to: equipment for surgical implementation, atomic energy control instruments, airplane or spaceship instruments, the control or operation of dynamic, brake or safety systems designed for vehicular use, traffic signal instruments, all types of safety devices, and other applications intended to support or sustain life.

All Insecure Usage shall be made at customer's risk, and in the event that third parties lay claims to Nuvoton as a result of customer's Insecure Usage, customer shall indemnify the damages and liabilities thus incurred by Nuvoton.

*Please note that all data and specifications are subject to change without notice.
All the trademarks of products and companies mentioned in this datasheet belong to their respective owners.*