



## 1. GENERAL DESCRIPTION

The W528Sxx family is programmable speech synthesis ICs that utilize the ADPCM coding method to generate all types of voice effects.

The W528Sxx's LOAD and JUMP commands and four programmable registers provide powerful user-programmable functions that make this chip suitable for an extremely wide range of speech IC applications.

The W528Sxx family includes 9 kinds of part numbers with the same function except for the voice duration shown below:

| ITEM   | W528S03 | W528S05 | W528S08A | W528S10 | W528S12 | W528S15 |
|--------|---------|---------|----------|---------|---------|---------|
| Second | 3 Sec   | 5 Sec   | 8 Sec    | 10 Sec  | 12 Sec  | 15 Sec  |
| ITEM   | W528S20 | W528S25 | W528S30  |         |         |         |
| Second | 20 Sec  | 25 Sec  | 30 Sec   |         |         |         |

**Note:** The voice durations are estimated by various sampling rate.

## 2. FEATURES

- Programmable speech synthesizer
- Wide operating voltage range: 2.4 to 5.5 volts
- 4-bit ADPCM synthesis method
- Provides 4 direct trigger inputs that can easily be extended to 8 or 12 matrix trigger inputs
- Two trigger input debounce times (20 to 40 mS or 160 to 320  $\mu$ S) can be set
- Provides up to 2 LEDs and 3 STOP outputs
- Every LED pin can drive 3 LEDs simultaneously
- LED flash frequency: 3 Hz
- AUD output current: 5 mA
- Flexible functions programmable through the following:
  - LD (load), JP (jump) commands
  - Four registers: R0, EN, STOP, and MODE
  - Conditional instructions
  - Speech equation
  - END instruction
  - Global repeat (GR) setting
  - Output frequency and LED flash type setting
- Programmable power-on initialization (POI) (can be interrupted by trigger inputs)
- POI delay time of 160 mS ensures stable voltage when chip is powered on
- Can be programmed for the following functions:

- Interrupt or non-interrupt for rising or falling edge of each trigger pin (this feature determines retriggerable, non-retriggerable, overwrite, and non-overwrite features of each trigger pin)
- Four playing modes:
  - One Shot (OS)
  - Level Hold (LH)
  - Single-cycle level hold (S\_LH)
  - Complete-cycle level hold (C\_LH)
- Stop output signal setting
- Serial, direct, or random trigger mode setting
- Four frequency options (4/4.8/6/8 KHz) and LED On/Off control can be set independently in each GO instruction of speech equation
- Independent control of LED1 and LED2
- Total of 256 voice group entries available for programming
- Provides the following mask options:
  - LED flash type: synchronous/alternate
  - LED1 section-controlled: Yes/No
  - LED2: section-controlled/STPC-controlled
  - LED volume-controlled: No/Yes

### 3. PAD CONFIGURATIONS

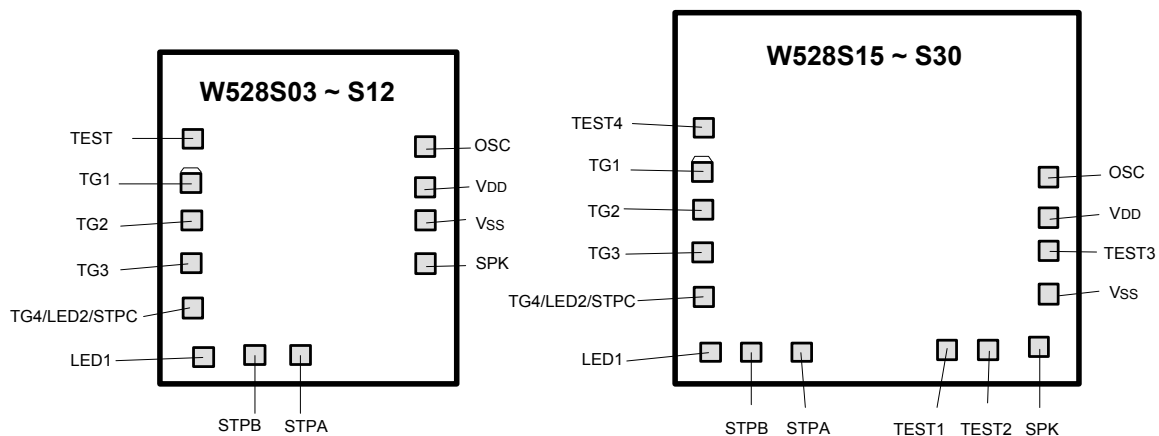

Note: TEST3 is /RESET pin.

#### 4. PAD DESCRIPTION

| PAD NAME      | I/O | FUNCTION                                  |
|---------------|-----|---|
| TG1           | I   | Trigger Input 1                           |
| TG2           | I   | Trigger Input 2                           |
| TG3           | I   | Trigger Input 3                           |
| TG4/LED2/STPC | I/O | Trigger Input 4 or LED 2 or Stop Signal C |
| LED1          | O   | LED 1                                     |
| STPB          | O   | Stop Signal B                             |
| STPA          | O   | Stop Signal A                             |
| SPK           | O   | Current Output for Speaker                |
| VSS           | -   | Negative Power Supply                     |
| VDD           | -   | Positive Power Supply                     |
| OSC           | I   | Oscillation Frequency Control             |
| *Test1        | -   | Test Pin                                  |
| *Test2        | -   | Test Pin                                  |
| *Test3        | -   | Test Pin or /Reset Pin                    |
| Test4         | -   | Test Pin                                  |

\* These pads only exist in W528S15 ~ W528S30.

## 5. BLOCK DIAGRAM

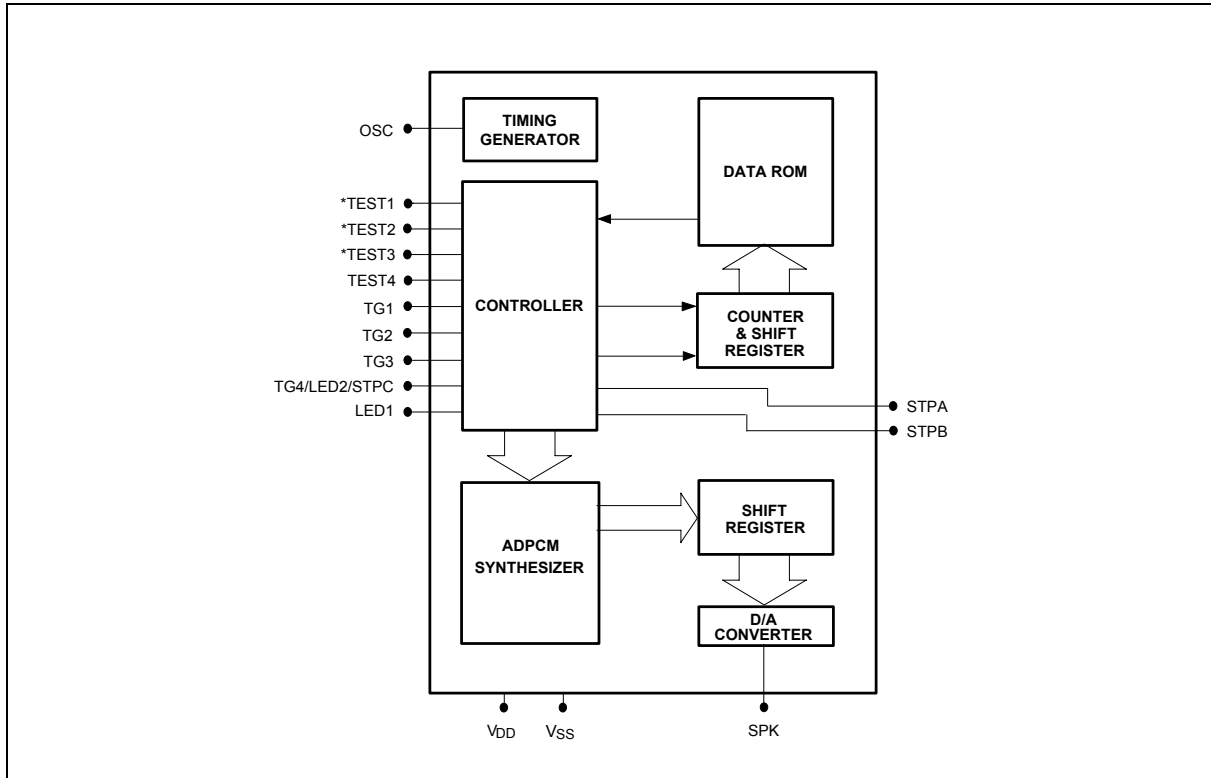

\* These pins only exist in W528S15 ~ W528S30.

## 6. FUNCTIONAL DESCRIPTION

The W528Sxx family provides up to four direct trigger pins, which can be extended to eight or twelve matrix trigger inputs, up to three stop signal output pins, an LED section control, and powerful programmable features. The JUMP and LOAD commands and four programmable registers can be used to program the desired playing mode, stop output signal form, LED flash type, and trigger pin interrupt modes.

The chip's programmable features can also be used to develop new, customized functions for a wide variety of innovative applications.

### 6.1 Instruction Set Description

This section describes three types of instructions:

- Unconditional instructions, which are executed immediately after they are issued.
- Conditional instructions, which are executed only when the conditions specified in the instructions are satisfied.
- END instruction, which is used to stop all device activity.



Instructions are programmed by writing LOAD and JUMP commands into the R0, EN, STOP, and MODE registers.

**Unconditional Instructions:**

1. LOAD (LD) Command:

LD R0, value:

This instruction is used to load a voice-group entry value into register R0. The voice-group entry value may range from 0 to 255. The initial value of the R0 register is "00000000."

LD EN, operand:

This instruction is used to define the trigger interrupt settings by loading the operand message into register EN. The initial value of the EN register is "11111111."

- a. The operand is an 8-bit value that can be entered in decimal (default) or hexadecimal (with "0x" as a prefix).
- b. EN is an 8-bit register that is used to enable/disable the rising/falling edge of each of the four trigger inputs.

The 8 bits correspond to the rising/falling edges of the triggers as shown below:

|      |    |    |    |    |    |    |    |    |
|------|----|----|----|----|----|----|----|----|
| Bit: | 7  | 6  | 5  | 4  | 3  | 2  | 1  | 0  |
| TG:  | 4R | 3R | 2R | 1R | 4F | 3F | 2F | 1F |

where "nR/F" represents the rising/falling edge of the n-th trigger pin.

- c. When any one of the eight bits is set to "1" (default), the corresponding trigger will interrupt the current state at the edge indicated. When the bits are set to "0," the triggers will be disabled.
- d. The voice group entry addresses correspond to the interrupt vectors as follows:

|        |    |    |    |    |    |    |    |    |
|--------|----|----|----|----|----|----|----|----|
| TG:    | 4R | 3R | 2R | 1R | 4F | 3F | 2F | 1F |
| Group: | 7  | 6  | 5  | 4  | 3  | 2  | 1  | 0  |

**EXAMPLE:**

The instruction "LD EN, 0x41" is programmed.

**EXPLANATION:**

- a. "41" is a hexadecimal value equal to the binary value "0100 0001."
- b. These 8 bits of data represent the following trigger interrupt settings:

|     |     |     |     |     |     |     |    |
|-----|-----|-----|-----|-----|-----|-----|----|
| 4R, | 3R, | 2R, | 1R, | 4F, | 3F, | 2F, | 1F |
|     |     |     |     |     |     |     |    |
| 0   | 1   | 0   | 0   | 0   | 0   | 0   | 1  |

**RESULT:**

- a. When the rising edge of TG3 (3R) is activated, the EN register will cause TG3 to interrupt the current playing state and jump immediately to voice group 6, the voice group that corresponds to 3R.



- b. When the falling edge of TG1 goes active, the EN register will cause TG1 to interrupt the current playing state and jump immediately to voice group 0, the voice group that corresponds to 1F.
- c. No action will be taken when the other trigger pins are pressed, because the corresponding bits are set to "0."

**LD STOP, operand:**

This instruction loads the operand message into the STOP register to set the output levels of the stop signals. The initial value of the STOP register is "XXXXX111."

- a. This register is used to program the output levels of the three STOP signals, STPA, STPB, and STPC. Only three of the bits in the register are used, as shown below (an "X" indicates "Don't care"):

|       |   |   |   |   |   |      |      |      |
|-------|---|---|---|---|---|------|------|------|
| Bit:  | 7 | 6 | 5 | 4 | 3 | 2    | 1    | 0    |
| Stop: | X | X | X | X | X | STPC | STPB | STPA |

- b. When a particular STOP bit is set to "1," The corresponding stop signal will be a high output; when a bit is set to "0," the corresponding stop signal will be a low output.

**EXAMPLE:**

The instruction "LD STOP, 0x43" is programmed.

**EXPLANATION:**

- a. "43" is a hexadecimal value equal to a binary value of "0100 0011."
- b. These 8 bits of data represent the following settings:

|    |    |    |    |    |       |       |      |
|----|----|----|----|----|-------|-------|------|
| X, | X, | X, | X, | X, | STPC, | STPB, | STPA |
|    |    |    |    |    |       |       |      |
| 0  | 1  | 0  | 0  | 0  | 0     | 1     | 1    |

**RESULT:**

- a. The STPA and STPB outputs will be high outputs.
- b. The STPC signal will be a low output.
- c. The sixth bit "1" is a "Don't Care" bit and so has no effect on the stop signal output settings.

**LD MODE, operand:**

This instruction is used to select various operating modes. It loads an operand message into the MODE register to select one mode from each of four pairs of modes, which correspond to bits 4 through 7 of the register (bits 0 to 3 are "Don't Care" bits). The four pairs of modes and the corresponding bits are as follows:

|       |          |           |               |              |   |   |   |   |
|-------|----------|-----------|---------------|--------------|---|---|---|---|
| Bit:  | 7        | 6         | 5             | 4            | 3 | 2 | 1 | 0 |
| MODE: | Flash/DC | LED2/STPC | TG4/LED2_STPC | 45 mS/350 μS | X | X | X | X |

A "1" for one of these bits selects the first of the pair of modes indicated; a "0" selects the second of the pair. The initial value of the mode register is "1111XXXX."



**EXAMPLE 1:**

The four bits are programmed as "1111," so that the eight bits of the register are as follows (an "X" indicates a "Don't Care" bit):

|           |            |                |                    |    |    |    |   |
|-----------|------------|----------------|--------------------|----|----|----|---|
| Flash/DC, | LED2/STPC, | TG4/LED2_STPC, | 45 mS/350 $\mu$ S, | X, | X, | X, | X |
|           |            |                |                    |    |    |    |   |
| 1         | 1          | 1              | 1                  | X  | X  | X  | X |

**RESULT:**

The mode settings are as follows:

- a. Pin 4 (TG4/LED2\_STPC) is configured as a trigger pin (TG4), and the LED2/STPC option will be ignored.
- b. The LED is set as a flash type, with a flash frequency of 3 Hz.
- c. The debounce time of the trigger inputs is set to 45 mS.

**EXAMPLE 2:**

The four bits are programmed as "0000," so that the eight bits of the register are as follows (an "X" indicates a "Don't Care" bit):

|           |            |                |                    |    |    |    |   |
|-----------|------------|----------------|--------------------|----|----|----|---|
| Flash/DC, | LED2/STPC, | TG4/LED2_STPC, | 45 mS/350 $\mu$ S, | X, | X, | X, | X |
|           |            |                |                    |    |    |    |   |
| 0         | 0          | 0              | 0                  | X  | X  | X  | X |

**RESULT:**

The mode settings are as follows:

- a. Pin 4 (TG4/LED2\_STPC) is configured as either the LED2 or STPC output (determined by bit 6, LED2/STPC; see next item).
- b. Pin 4 is configured as the STPC output pin.
- c. LED will be lit constantly during operation.
- d. The debounce time of the trigger inputs is set as 350  $\mu$ S.

**2. JUMP (JP) Command:**

JP value: Instructs device to jump directly to the voice group corresponding to the value indicated. The voice group value may range from 0 to 127 (direct jump).

JP R0: Instructs device to jump to whatever voice group is indicated by the value currently stored in register R0, from 0 to 255 (indirect jump).



## 6.2 Conditional Instructions

Conditional instructions are executed only when the conditions specified in the instructions hold. The conditional instructions are listed below. An explanation of the notation used in the instructions follows.

(Note: There are no conditional instructions for LD MODE.)

LD R0, VALUE @LAST: VALUE can be set from 0 to 255.

LD R0, VALUE @TGn\_STATUS: VALUE can be set from 0 to 255.

LD EN, OPERAND @LAST: EN - 4R, 3R, 2R, 1R, 4F, 3F, 2F, 1F.

LD STOP, OPERAND @LAST: STOP - X, X, X, X, X, STPC, STPB, STPA.

JP VALUE @LAST: VALUE can be set from 0 to 127.

JP R0 @LAST

JP VALUE @TGn\_STATUS: VALUE can be set from 0 to 127

JP R0 @TGn\_STATUS

EXPLANATION:

@LAST: At last time of global repeat.

@TGn\_STATUS: When the status of the trigger specified (TGn) is in the condition specified, where the possible triggers and conditions are the following:

TG1\_HIGH

TG1\_LOW

TG2\_HIGH

TG2\_LOW

TG3\_HIGH

TG3\_LOW

TG4\_HIGH

TG4\_LOW

## 6.3 End Instruction

END: This command instructs the chip to cease all activity immediately.

## 6.4 Program Structure Features and Execution Rules

1. There are eight hardware group entry points and 248 software group entry points, as follows:

|                |       | Group |
|----------------|-------|-------|
| 8 H/W entries: | TG1F: | 0     |
|                | TG2F: | 1     |
|                | TG3F: | 2     |
|                | TG4F: | 3     |
|                | TG1R: | 4     |



(Continued)

|                  |       |     |
|------------------|-------|-----|
|                  | TG2R: | 5   |
|                  | TG3R: | 6   |
|                  | TG4R: | 7   |
| 248 S/W entries: |       | 8   |
|                  |       | 9   |
|                  |       | .   |
| POI:             |       | 32  |
|                  |       | 33  |
|                  |       | .   |
|                  |       | .   |
|                  |       | .   |
|                  |       | 254 |
|                  |       | 255 |

2. Execution begins from group entry and is terminated by END instruction.
3. A H/W trigger interrupt stops the group currently being executed immediately and begins a new group.

## 6.5 Mask Options

There are four mask options for the W528Sxx family; the mask options are used to select features that cannot be programmed through the chip's registers.

The options are the following:

- LED flash type (synchronous/alternate)
- LED volume-controlled: No/Yes
- LED1 section-controlled: Yes/No
- LED2: section-controlled/STPC-controlled

## 6.6 Speech Equation Description

The format of the speech equations for the W528Sxx family is shown as below example:

```
GR = N
H4+m1*SOUND1_FL+m2*SOUND2_FL+[1FFFF]+...+T4
END
```

where

- GR = N defines the number of global repeats (from 1 to 16);
- m1 and m2 define the number of local repeats (from 1 to 7);



SOUND1 and SOUND2 are the \*.WAM files of ADPCM converted voice data;  
 \_FL is the section control setting, for which the parameters F and L are as follows:  
 F: Voice output frequency setting:  
 0 = 4 KHz, 1 = 4.8 KHz, 2 = 6 KHz, 3 = 8 KHz;  
 L: LED output setting:  
 1: ON  
 0: OFF; and  
 [1FFFF] is a period of silence of length 1FFFF;  
 H4, T4: Represent head and tail ADPCM files, respectively.

## 6.7 Programmable Power-on Initialization

Whenever the W528Sxx is powered on, the program contained in the 32nd voice group will be executed after the power-on delay (about 160 mS), so the user can write a program into this group to set the power-on initial state. If the user does not wish to execute a program at power-on, an "END" instruction should be entered in group 32. The W528Sxx power-on initialization process can be interrupted by trigger inputs.

## 6.8 Programming Examples

This section presents several examples of how the functions of the W528Sxx may be programmed. Customer programs should be written in ASCII code using a text editor; after compiling, the sound effects resulting from the programs can be tested using a Winbond demo board.

EXAMPLE1: Four playing mode settings:

a. One-Shot Trigger Mode

```
0: LD EN, 0x01          ; Enable TG1 falling edge input only.
  H4 + sound1 + T4
  END
```

The timing diagram for this example is shown below:

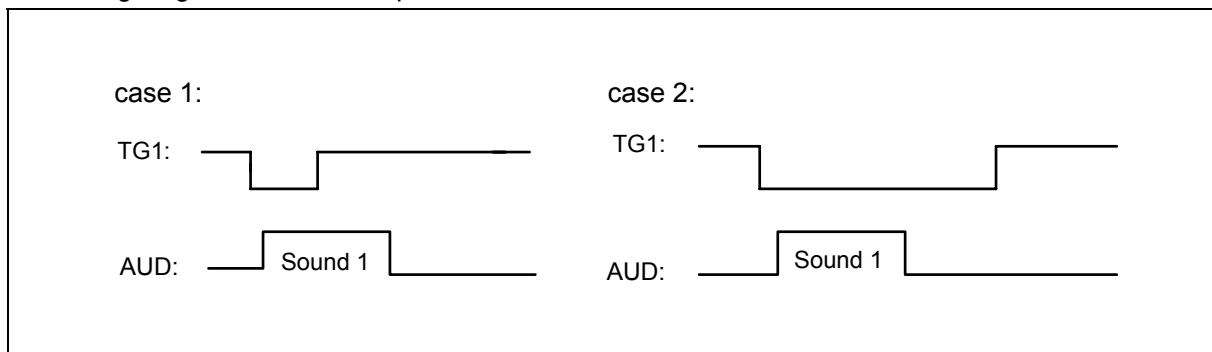



- b. Level-Hold Trigger Mode
- 0: LD EN, 0x11 ; Enable TG1 rising/falling edge input.
- H4 + sound1 + T4
- JP 0 ; Repeat sound1 until TG1 key released.
- 4: END ; As soon as TG1 key is released, execute this group entry.

The timing diagram is shown below:

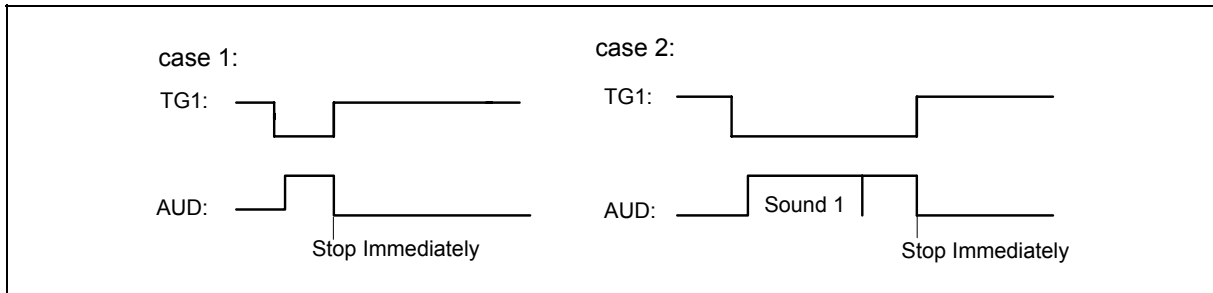

- c. Complete-Cycle Level Hold
- 0: LD EN, 0x01 ; Enable TG1 falling edge only.
- H4 + sound1 + T4
- JP 0 @TG1\_LOW ; If TG1 status is low level voltage (trigger is pressed), then j ump to 0;
- if not, execute next instruction (END).
- END

The timing diagram is shown below:

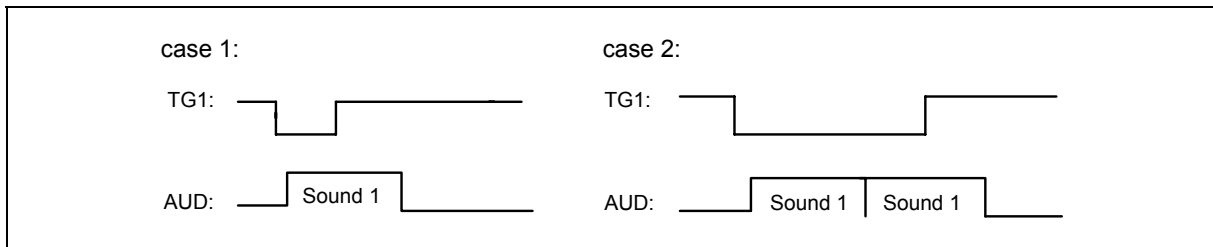

- d. Single-Cycle Level Hold
- 0: LD EN, 0x11 ; Enable both falling and rising edge input of TG1.
- H4 + sound1 + T4
- END
- .
- .
- .
- 4: END ; As soon as TG1 is key released, execute this group entry.



The timing diagram is shown below:

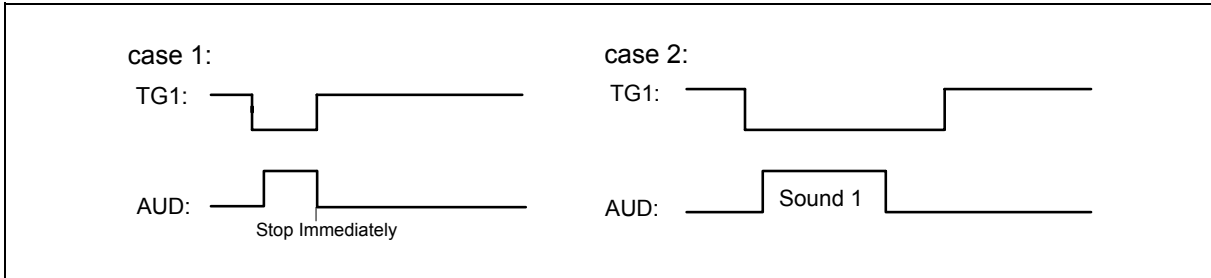

EXAMPLE 2: Retriggerable and Non-retriggerable setting

a. Retriggerable:

```
0: LD EN, 0x01      ; 0x01 = 00000001B, only TG1 falling edge interrupt is enabled.
END
.
.
.
END
```

The timing diagram is shown below:

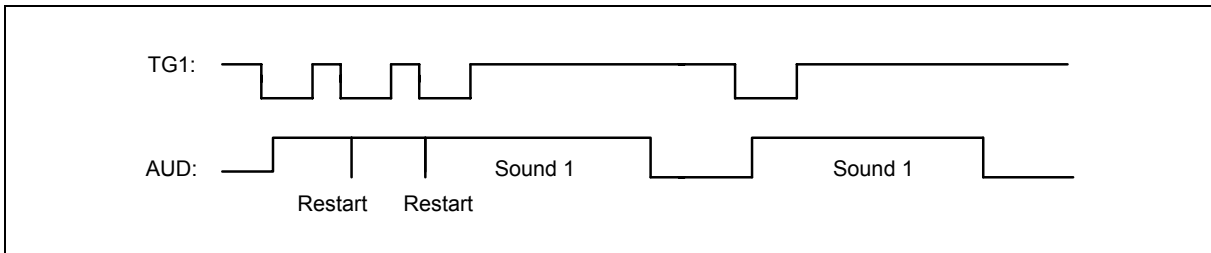

b. Non-retriggerable:

```
0: LD EN, 0x00      ; 0x00 = 00000000B, TG1 falling edge interrupt is disabled.
.
.
LD EN, 0x11         ; Recover the TG1 falling and rising edge interrupt is enabled.
END
```

The timing diagram is shown below:

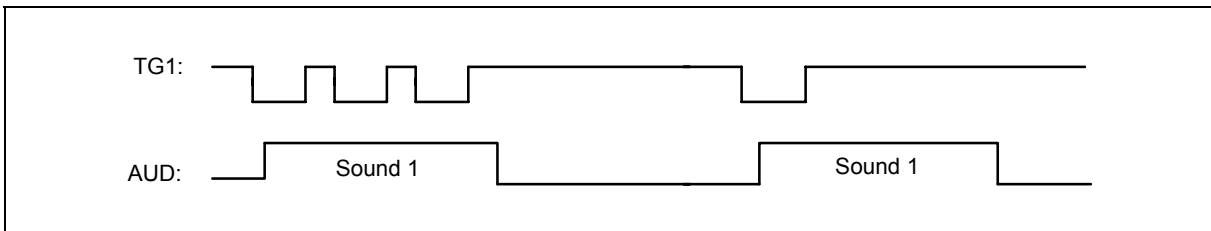



## 7. ELECTRICAL CHARACTERISTICS

### 7.1 Absolute Maximum Ratings

| PARAMETER       | SYMBOL  | CONDITIONS | RATED VALUE          | UNIT |
|-----------------|---------|------------|----------------------|------|
| Power Supply    | VDD-VSS | -          | -0.3 to +7.0         | V    |
| Input Voltage   | VIN     | All Inputs | VSS -0.3 to VDD +0.3 | V    |
| Storage Temp.   | TSTG    | -          | -55 to +150          | °C   |
| Operating Temp. | TOPR    | -          | 0 to +70             | °C   |

**Note:** Exposure to conditions beyond those listed under Absolute Maximum Ratings may adversely affect the life and reliability of the device.

### 7.2 DC Characteristics

(TA = 25° C, VSS = 0 V)

| PARAMETER                                   | SYM.                             | CONDITIONS                     | LIMITS                |      |            | UNIT |   |
|---|----------------------------------|--------------------------------|-----------------------|------|------------|------|---|
|   |                                  |                                | MIN.                  | TYP. | MAX.       |      |   |
| Operating Voltage                           | VDD                              | -                              | 2.4                   | 3    | 5.5        | V    |   |
| Input Voltage                               | VIL                              | All Input Pins                 | VSS<br>-0.3           | -    | 0.3<br>VDD | V    |   |
|   | VIH                              |                                | 0.7 VDD               | -    | VDD        |      |   |
| Standby Current                             | IDD1                             | VDD = 3V, No Playing           | -                     | -    | 0.2        | μA   |   |
|   | IDD2                             | VDD = 5V, No Playing           | -                     | -    | 0.4        |      |   |
| Operating Current                           | IOP1                             | VDD = 3V, No Load              | -                     | -    | 400        | μA   |   |
|   | IOP2                             | VDD = 5V, No Load              | -                     | -    | 800        |      |   |
| Input Current for TG1-TG4                   | IIN                              | VDD = 3V, VIN = 0V             | -                     | -    | 6          | μA   |   |
| SPK (D/A Full Scale)                        | IO1                              | VDD = 4.5V, RL = 100 Ω         | -4.0                  | -5.0 | -6.0       | mA   |   |
| Output Current of STPC                      | IO1                              | VDD = 3V, VOUT = 0.4V          | 1                     | -    | -          | mA   |   |
|   | IOH                              | VDD = 3V, VOUT = 2.7V          | -0.5                  | -    | -          |      |   |
| Output Current                              | LED1<br>LED2                     | IO                             | VDD = 3V, VOUT = 1V   | 10   | -          | mA   |   |
|   |                                  | IO                             | VDD = 4.5V, VOUT = 1V | 15   | -          |      |   |
|   | STPA<br>STPB                     | IO1                            | VDD = 3V, VOUT = 0.4V | 1    | 3          |      | - |
|   |                                  | IOH                            | VDD = 3V, VOUT = 2.7V | -1   | -3         |      | - |
| Oscillation Freq.                           | FOSC                             | VDD = 3V, ROSC = Typ.          | 2.7                   | 3    | 3.3        | MHz  |   |
|   |                                  | VDD = 4.5V, ROSC = Typ.        | 2.7                   | 3    | 3.3        |      |   |
| Oscillation Freq. Deviation by Voltage Drop | $\frac{\Delta F_{OSC}}{F_{OSC}}$ | $\frac{F(3V) - F(2.4)}{F(3V)}$ | 0                     | 4    | 7.5        | %    |   |
| Input Debounce Time                         | TDEB1                            | FOSC = 3 MHz,<br>SR = 6 KHz    | 45                    | -    | -          | mS   |   |
|   | TDEB2                            |                                | 350                   | -    | -          | μS   |   |

**Note:** Rosc = 430KOhm for all items in W528Sxx

## 8. APPLICATION CIRCUIT

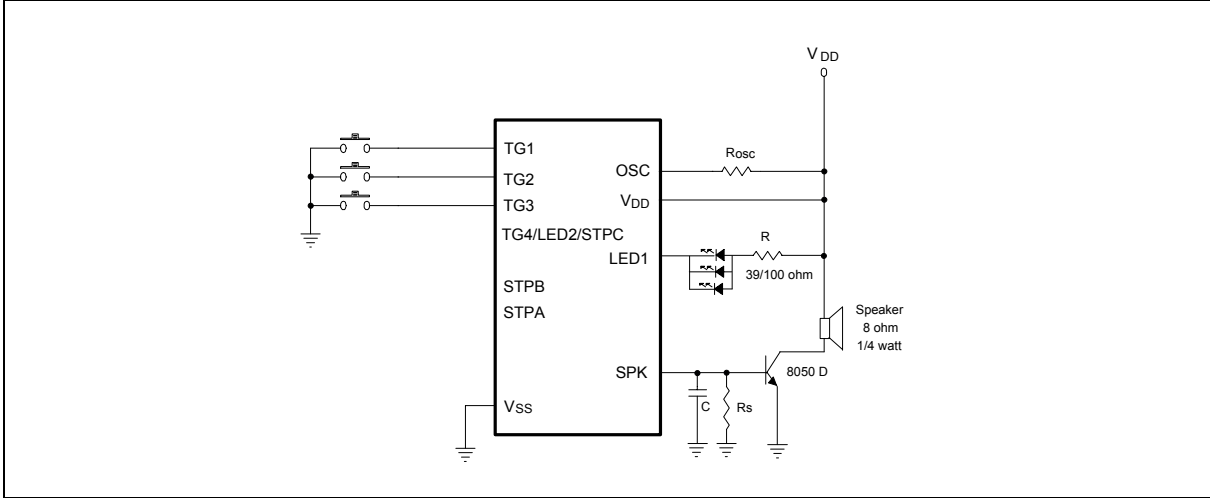

### Notes:

1. In principle, the playing speed determined by ROSC should correspond to the sampling rate during the coding phase. The playing speed may be adjusted by varying ROSC, however.
2. Rs is an optional current-dividing resistor. If Rs is added, the resistance should be between 470 and 750Ω.
3. Cs is optional.
4. The DC current gain  $\beta$  of transistor 8050 ranges from 120 to 200.
5. All unused trigger pins can be left open because of their internal pull-high resistance.
6. R is used to limit the current on the LED. Case 1:  $V_{DD} = 3V$ ,  $R = 39\Omega$  for 1/2/3 LEDs.  
Case 2:  $V_{DD} = 4.5V$ ,  $R = 39\Omega$  for 2/3 LEDs and  $R = 100\Omega$  for 1 LED.
7. No warranty for production.

## 8.1 Supplement

### A. Power Bouncing

If an irregularity (such as bouncing) occurs in the power supply to  $V_{DD}$ , as shown in the diagram, the W528Sxx may hang or the logic state machine may lock up. To return the chip to normal operation, short  $V_{DD}$  and  $V_{SS}$  for the W528Sxx and then release again.

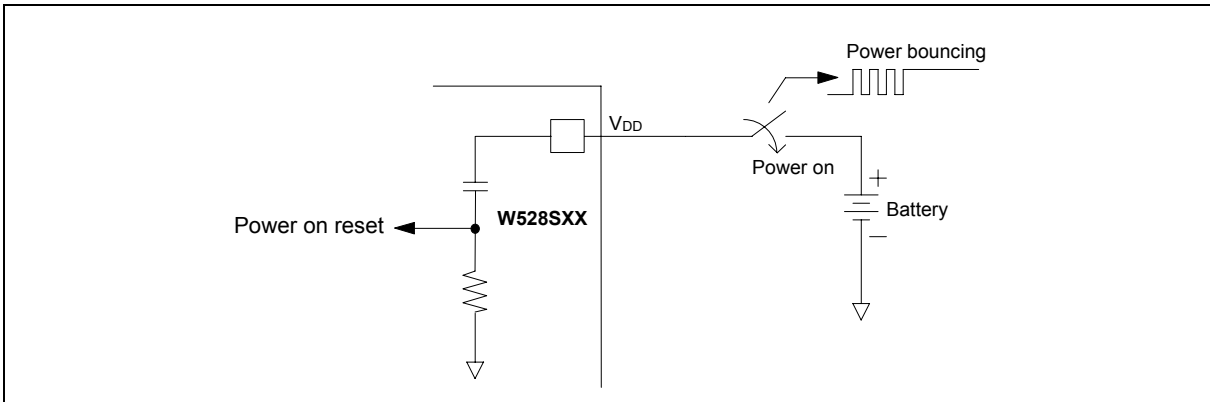

## B. Trigger Pin Coupling Effect

The trigger pins (TG1–TG4) are built-in 500K $\Omega$  pull high resistor.

If the wire of the input trigger is very close to the speaker wire in the application environment, the coupling effect will occur. The input voltage of the trigger pin will be unstable, causing the trigger operation to become abnormal.

An external pull high resistor ( $R_i$ ) connecting the trigger pin and VDD can resolve this problem. The value of the  $R_i$  depends on your application environment.

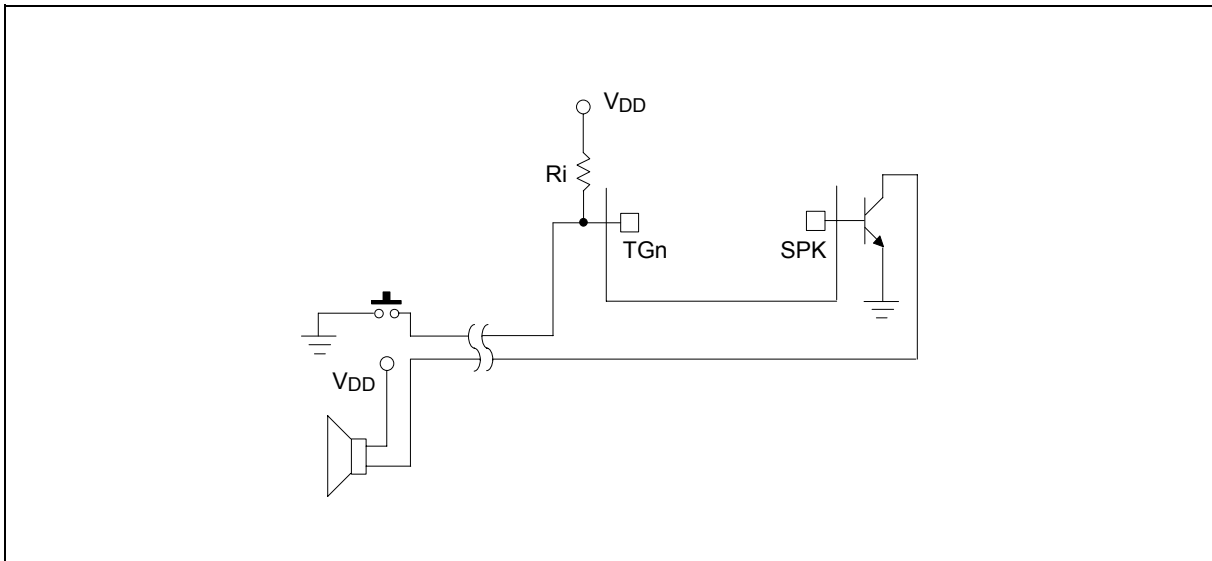



## 9. REVISION HISTORY

| REVISION | DATE          | MODIFICATIONS   |
|----------|---------------|---|
| A1       | Mar. 1999     | Preliminary release.  |
| A2       | June 13, 2003 | In DC spec., modify minimum input debounce time as 45 mS and 350 $\mu$ S. |



**Headquarters**  
 No. 4, Creation Rd. III,  
 Science-Based Industrial Park,  
 Hsinchu, Taiwan  
 TEL: 886-3-5770066  
 FAX: 886-3-5665577  
<http://www.winbond.com.tw/>

**Taipei Office**  
 9F, No.480, Rueiguang Rd.,  
 Neihu District, Taipei, 114,  
 Taiwan, R.O.C.  
 TEL: 886-2-8177-7168  
 FAX: 886-2-8751-3579

**Winbond Electronics Corporation America**  
 2727 North First Street, San Jose,  
 CA 95134, U.S.A.  
 TEL: 1-408-9436666  
 FAX: 1-408-5441798

**Winbond Electronics Corporation Japan**  
 7F Daini-ueno BLDG, 3-7-18  
 Shinyokohama Kohoku-ku,  
 Yokohama, 222-0033  
 TEL: 81-45-4781881  
 FAX: 81-45-4781800

**Winbond Electronics (Shanghai) Ltd.**  
 27F, 2299 Yan An W. Rd. Shanghai,  
 200336 China  
 TEL: 86-21-62365999  
 FAX: 86-21-62365998

**Winbond Electronics (H.K.) Ltd.**  
 Unit 9-15, 22F, Millennium City,  
 No. 378 Kwun Tong Rd.,  
 Kowloon, Hong Kong  
 TEL: 852-27513100  
 FAX: 852-27552064

*Please note that all data and specifications are subject to change without notice.  
 All the trade marks of products and companies mentioned in this data sheet belong to their respective owners.*