

Adjustable Frequency Buck or Buck/Boost Pre-Regulator with a Synchronous Buck, 3 Internal LDOs, Window Watchdog Timer, and NPOR

FEATURES AND BENEFITS

- Automotive AEC-Q100 qualified
- 2.8 V_{IN} to 36 V_{IN} operating range, 40 V_{IN} maximum
- Buck or buck/boost pre-regulator (VREG)
- Adjustable PWM switching frequency: 250 kHz – 2.4 MHz
- PWM frequency can be synchronized to external clock
- 1.25 V/750 mA_{DC}/1 A_{PEAK} synchronous buck (1V25)
- 3.3 V (3V3) and 5 V (V5) internal LDO regulators with fold back short circuit protections
- 5 V (V5P) internal tracking LDO regulator with fold back short circuit and short-to-battery protections
- TRACK sets either 3V3 or V5 as the reference for V5P
- Power-on reset with fixed delay of 15 ms for 1V25/3V3 UV and OV protection (NPOR)
- Programmable watchdog timer with a 30 ms activation delay
- Active low, watchdog timer enable/disable pin (WD_{ENn})
- Dual band gaps for increased reliability: BG_{VREF}, BG_{FAULT}

Continued on next page...

APPLICATIONS

- Automotive Control Modules for:
 - Electronic Power Steering (EPS)
 - Transmission Control (TCU)
 - Advanced Braking Systems (ABS)
 - Emissions Control Modules
 - Other automotive applications

PACKAGE: 38-Pin eTSSOP (suffix LV)

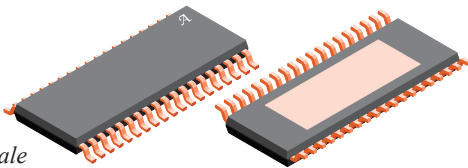

Not to scale

DESCRIPTION

The A4410 is power management IC that uses a buck or buck/boost pre-regulator to efficiently convert automotive battery voltages into a tightly regulated intermediate voltage complete with control, diagnostics, and protections. The output of the pre-regulator supplies a 5 V/250 mA_{MAX} tracking/protected LDO, a 3.3 V/160 mA_{MAX} LDO, a 5 V/150 mA_{MAX} LDO, and a 1.25 V/750 mA_{DC}/1 A_{PEAK} synchronous buck regulator. Designed to supply CAN or microprocessor power supplies in high temperature environments the A4410 is ideal for under hood applications.

Enable inputs to the A4410 include a logic level (ENB) and two high-voltage (ENBAT1 and ENBAT2). The A4410 provides flexibility by including a TRACK pin to set the reference of the tracking regulator to either the 5 V or the 3.3 V output, so the A4410 can be adapted across multiple platforms with different sensors and supply rails.

Diagnostic outputs from the A4410 include a power-on-reset output (NPOR) with a fixed 15 ms delay, an ENBAT1 and ENBAT2 status outputs, and a PowerOK output for the 5 V and 5 V protected LDOs (POK5V). Dual bandgaps, one for regulation and one for fault checking, improve long-term reliability of the A4410.

The A4410 contains a Window Watchdog timer that can be programmed to accept a wide range of clock frequencies (WD_{ADJ}). The watchdog timer has a fixed 30 ms activation delay to accommodate processor startup. The watchdog timer has an enable/disable pin (active LOW, WD_{ENn}) to facilitate initial factory programming or field re-flash programming.

Protection features include under and over voltage lockout on all four CPU supply rails. In case of a shorted output, all linear regulators feature fold back over current protection. In addition, the V5P output is protected from a short-to-battery event. Both

Continued on next page...

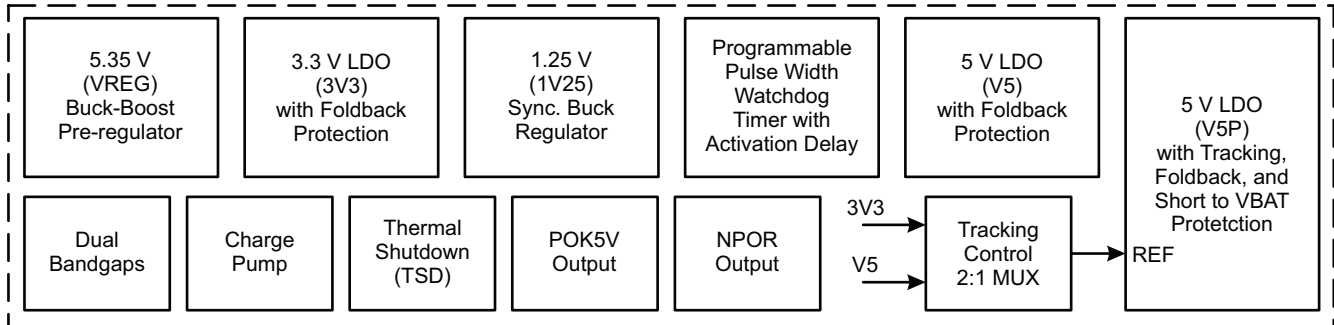

A4410 Simplified Block Diagram

A4410

Adjustable Frequency Buck or Buck/Boost Pre-Regulator with a Synchronous Buck, 3 Internal LDOs, Window Watchdog Timer, and NPOR

Features and Benefits (continued)

- PowerOK output for V5/V5P UV and OV (POK5V)
- Logic enable input (ENB) for microprocessor control
- Two ignition enable inputs (ENBAT1 and ENBAT2)
- ENBAT1 and ENBAT2 status indicator outputs
- SLEW rate control pin helps reduce EMI/EMC
- Frequency dithering helps reduce EMI/EMC
- OV and UV protection for all four CPU supply rails
- Pin-to-pin and pin-to-ground tolerant at every pin
- Thermal shutdown protection
- -40°C to 150°C junction temperature range

Description (continued)

switching regulators include pulse-by-pulse current limit, hiccup mode short circuit protection, LX short circuit protection, missing asynchronous diode protection (VREG only) and thermal shutdown.

The A4410 is supplied in a low profile, 38-lead eTSSOP package (suffix “LV”) with exposed power pad.

Selection Guide

Part Number	Temp. Range	Package	Packing ¹	Lead Frame
A4410KLVTR-T	-40 to 135°C	38-pin eTSSOP w/ thermal pad	4000 pieces per 7-in reel	100% Matte Tin

¹ Contact Allegro for additional packing options.



SPECIFICATIONS

Absolute Maximum Ratings¹

Characteristic	Symbol	Notes	Rating	Unit	
V _{IN}	V _{VIN}		-0.3 to 40	V	
ENBAT1, ENBAT2	V _{ENBATx}	With current limiting resistor ²	-13 to 40	V	
			-0.3 to 8		
	I _{ENBATx}		±75	mA	
LX1, SLEW			-0.3 to V _{VIN} +0.3	V	
			t < 250 ns		-1.5
			t < 50 ns		V _{VIN} +3 V
VCP, CP1, CP2			-0.3 to 50	V	
V5P	V _{V5P}		-1.0 to 40 ³	V	
All other pins			-0.3 to 7	V	
Ambient Temperature	T _A	Range K for automotive	-40 to 135	°C	
Junction Temperature	T _J		-40 to 150	°C	
Storage Temperature Range	T _S		-40 to 150	°C	

¹ Stresses beyond those listed in this table may cause permanent damage to the device. The absolute maximum ratings are stress ratings only, and functional operation of the device at these or any other conditions beyond those indicated in the Electrical Characteristics table is not implied. Exposure to absolute-maximum-rated conditions for extended periods may affect device reliability.

² The higher ENBAT1 and ENBAT2 ratings (-13 V and 40 V) are measured at node "A" in the following circuit configuration:

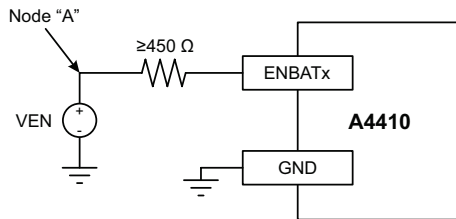

³ Independent of V_{VIN}.

Table 3: Thermal Characteristics

(may require derating at maximum conditions, see application information)

Characteristic	Symbol	Test Conditions*	Value	Unit
Junction to Pad Thermal Resistance	R _{θJC}	eTSSOP-38 (LV) Package	30	°C/W

*Additional thermal information available on the Allegro website.

A4410

Adjustable Frequency Buck or Buck/Boost Pre-Regulator with a Synchronous Buck, 3 Internal LDOs, Window Watchdog Timer, and NPOR

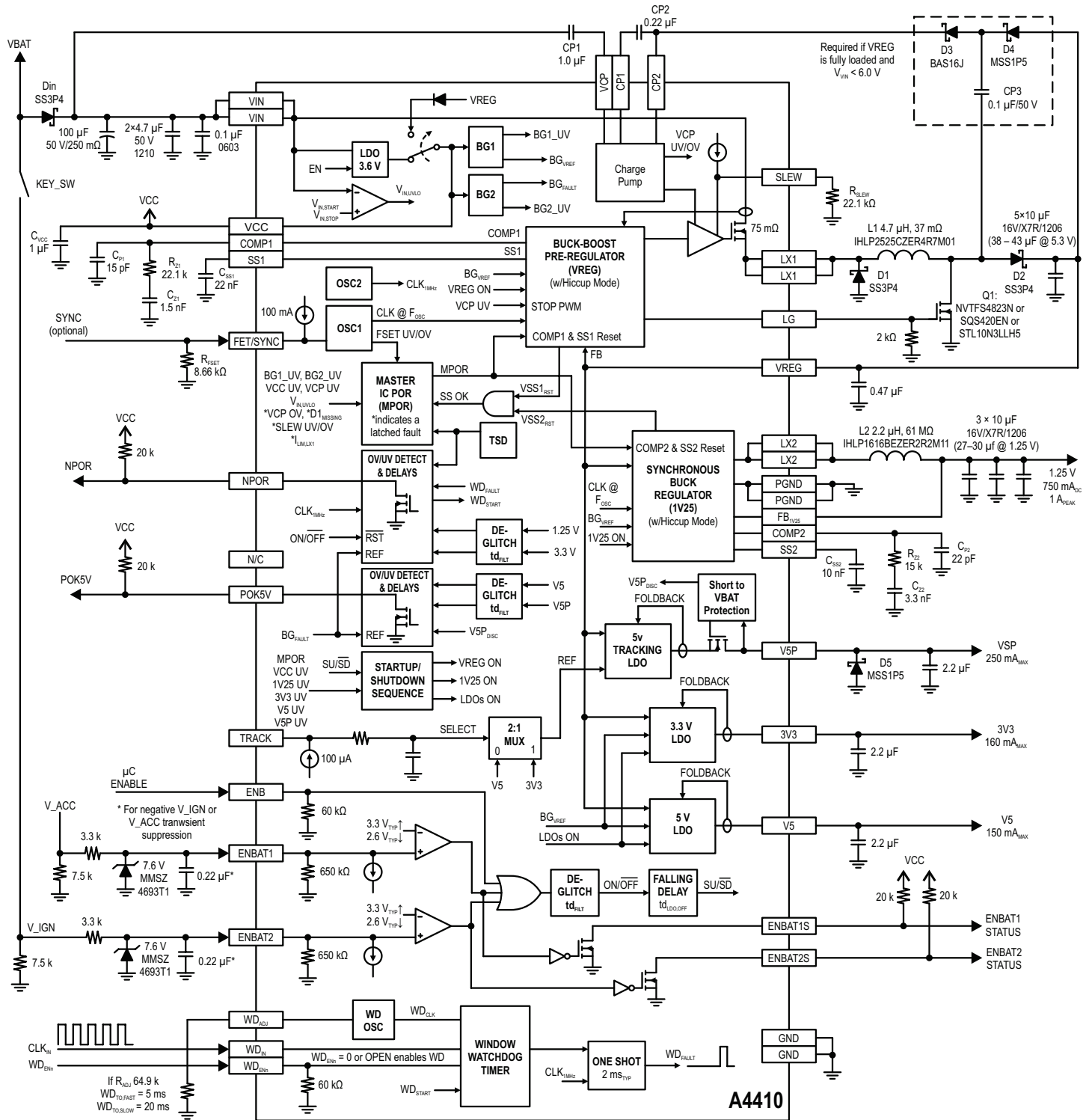

Functional Block Diagram/Typical Schematic

Buck-Boost Mode ($f_{OSC} = 2 \text{ MHz}$)

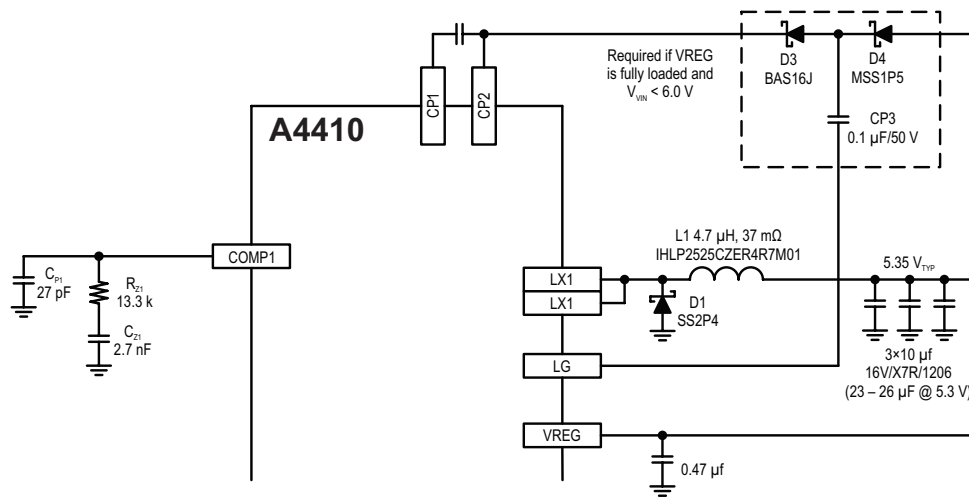

Functional Block Diagram Modifications for Buck Only Mode ($f_{OSC} = 2.0 \text{ MHz}$)

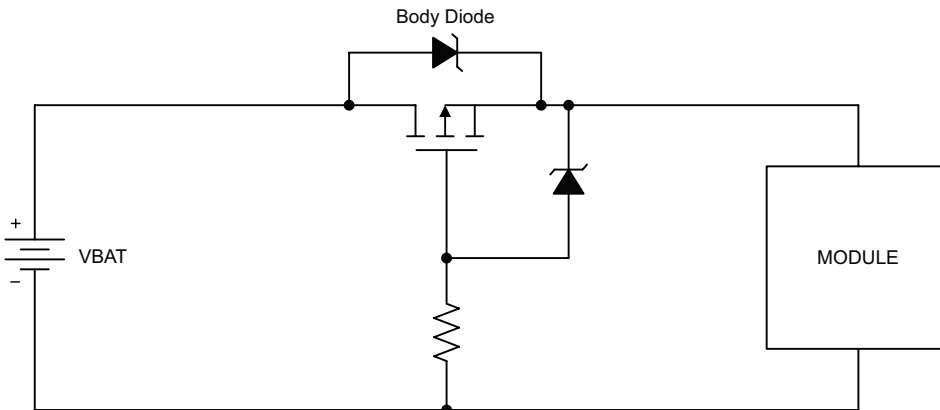

Functional Block Diagram Using a PMOS FET for Reverse Battery Protection Instead of a Series Schottky Diode (D_{IN})

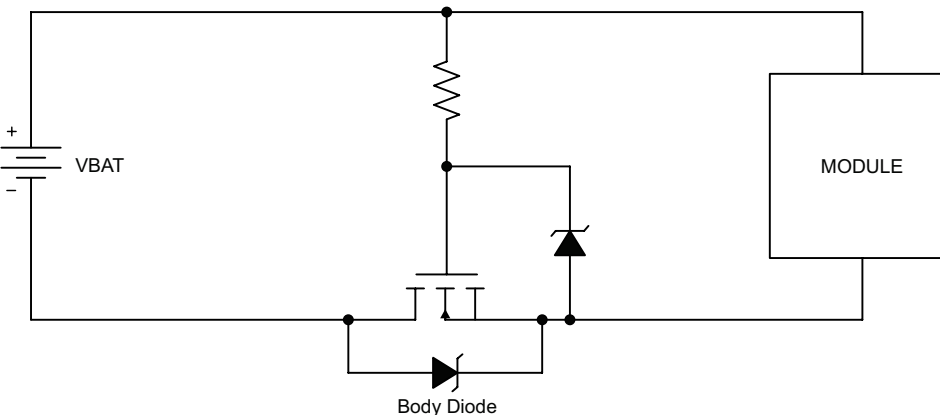

Functional Block Diagram Using an NMOS FET for Reverse Battery Protection Instead of a Series Schottky Diode (D_{IN})

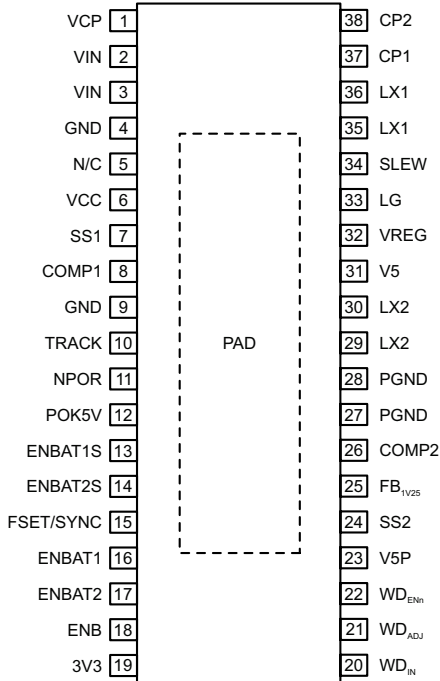

**Package LV, 38-Pin eTSSOP
Pin-out Diagram**

Terminal List Table

Number	Name	Function
1	VCP	Charge pump reservoir capacitor
2,3	VIN	Input voltage
4,9	GND	Ground
5	N/C	No Connect
6	VCC	Internal voltage regulator bypass capacitor pin
7	SS1	Soft start programming pin for the buck/boost pre-regulator
8	COMP1	Error amplifier compensation network pin for the buck/boost pre-regulator
10	TRACK	Tracking control: Open/High – V5P tracks 3V3, GND/Low – V5P tracks V5
11	NPOR	Active LOW, open-drain regulator fault detection output
12	POK5V	PowerOK output indicating when either the V5 or V5P rail is under-voltage (UV)
13	ENBAT1S	Open drain ignition status output, for ENBAT1 only
14	ENBAT2S	Open drain ignition status output, for ENBAT2 only
15	FSET/ SYNC	Frequency setting and synchronization input
16	ENBAT1	Ignition enable input from the key/switch via a 1K of resistance
17	ENBAT2	Ignition enable input from the key/switch via a 1K of resistance
18	ENB	Logic enable input from the micro-controller
19	3V3	3.3 V regulator output
20	WD _{IN}	Watchdog refresh input (rising edge triggered) from a micro-controller or DSP
21	WD _{ADJ}	The watchdog wait/delay time is programmed by connecting R _{ADJ} from this pin to ground
22	WD _{EN}	Watchdog enable pin: Open/Low – WD is enabled, High – WD is disabled
23	V5P	5 V tracking/protected regulator output
24	SS2	Soft start programming pin for the 1.25 V synchronous buck
25	FB1V25	Feedback pin for the 1.25 V regulator
26	COMP2	Error amplifier compensation network pin for the 1.25 V synchronous regulator
27,28	PGND	Power ground for the 1.25 V synchronous regulator / gate driver
29,30	LX2	Switching node for the 1.25 V synchronous regulator
31	V5	5 V regulator output
32	VREG	Output of the buck-boost and input for the LDOs and 1.25 V _{OUT} sync. Buck
33	LG	Boost gate drive output for the buck/boost pre-regulator
34	SLEW	Slew rate adjustment for the rise time of LX1
35,36	LX1	Switching node for the buck/boost pre-regulator
37	CP1	Charge pump capacitor connection
38	CP2	Charge pump capacitor connection
–	PAD	

ELECTRICAL CHARACTERISTICS – GENERAL SPECIFICATIONS¹: valid at $3.6\text{ V} < V_{\text{IN}} < 36\text{ V}$, $-40^{\circ}\text{C} < T_{\text{A}} = T_{\text{J}} < 150^{\circ}\text{C}$, unless otherwise specified.

Characteristic	Symbol	Test Conditions	Min.	Typ.	Max.	Unit
General Specifications						
Operating Input Voltage	V_{VIN}	After $V_{\text{VIN}} > V_{\text{VIN,START}}$, and $V_{\text{ENB}} > 2.0\text{ V}$ or $V_{\text{ENBATx}} > 3.5\text{V}$, Buck-Boost Mode	2.8	13.5	36	V
		After $V_{\text{VIN}} > V_{\text{VIN,START}}$, and $V_{\text{ENB}} > 2.0\text{ V}$ or $V_{\text{ENBATx}} > 3.5\text{V}$, Buck Mode	5.1	13.5	36	
VIN UVLO START Voltage	$V_{\text{IN,START}}$	V_{VIN} rising	4.55	4.80	5.05	V
VIN UVLO STOP Voltage	$V_{\text{IN,STOP}}$	V_{VIN} falling, $V_{\text{ENBATx}} \geq 3.6\text{ V}$ or $V_{\text{ENB}} \geq 2.0\text{ V}$, $V_{\text{VREG}} = 5.2\text{ V}$	2.52	2.65	2.78	V
VIN UVLO Hysteresis	$V_{\text{IN,HYS}}$	$V_{\text{IN,START}} - V_{\text{IN,STOP}}$	—	2.2	—	V
Supply Quiescent Current ¹	I_{Q}	$V_{\text{VIN}} = 13.5\text{ V}$, $V_{\text{ENBATx}} \geq 3.6\text{ V}$ or $V_{\text{ENB}} \geq 2.0\text{ V}$, $V_{\text{VREG}} = 5.6\text{ V}$ (no PWM)	—	13	—	mA
	$I_{\text{Q,SLEEP}}$	$V_{\text{VIN}} = 13.5\text{ V}$, $V_{\text{ENBATx}} \leq 2.2\text{ V}$ and $V_{\text{ENB}} \leq 0.8\text{ V}$	—	—	10	μA
PWM Switching Frequency and Dithering						
Switching Frequency	f_{OSC}	$R_{\text{FSET}} = 8.66\text{ k}\Omega$	1.8	2.0	2.2	MHz
		$R_{\text{FSET}} = 20.5\text{ k}\Omega$ ²	—	1.0	—	
		$R_{\text{FSET}} = 57.6\text{ k}\Omega$ ²	343	400	457	kHz
Frequency Dithering	Δf_{OSC}	As a percent of f_{OSC}	—	± 12	—	%
Dither/Slew START Threshold	$V_{\text{IN,DS,ON}}$		8.5	9.0	9.5	V
Dither/Slew STOP Threshold	$V_{\text{IN,DS,OFF}}$		7.8	8.3	8.8	V
VIN Dithering/Slew Hysteresis			—	700	—	mV
Charge Pump (VCP)						
Output Voltage	V_{VCP}	$V_{\text{VCP}} - V_{\text{VIN}}$, $V_{\text{VIN}} = 13.5\text{ V}$, $V_{\text{VREG}} = 5.50\text{ V}$, $I_{\text{VCP}} = 6.5\text{ mA}$, $V_{\text{COMP1}} = V_{\text{COMP2}} = 0\text{ V}$, $V_{\text{ENB}} = 3.3\text{ V}$	4.1	6.6	—	V
		$V_{\text{VCP}} - V_{\text{VIN}}$, $V_{\text{VIN}} = 6.5\text{ V}$, $V_{\text{VREG}} = 5.50\text{ V}$, $I_{\text{VCP}} = 6.5\text{ mA}$, $V_{\text{COMP1}} = V_{\text{COMP2}} = 0\text{ V}$, $V_{\text{ENB}} = 3.3\text{ V}$	3.1	3.8	—	
Switching Frequency	$f_{\text{SW,CP}}$		—	65	—	kHz
VCC Pin Voltage						
Output Voltage	V_{VCC}	$V_{\text{VREG}} = 5.35\text{ V}$	—	4.65	—	V
Thermal Protection						
Thermal Shutdown Threshold ²	T_{TSD}	T_{J} rising	155	170	185	$^{\circ}\text{C}$
Thermal Shutdown Hysteresis ²	T_{HYS}		—	20	—	

¹ Negative current is defined as coming out of the node or pin (sourcing), positive current is defined as going into the node or pin (sinking).

² Ensured by design and characterization, not production tested.

³ Specifications at 25°C or 85°C are guaranteed by design and characterization, not production tested.

⁴ The lowest operating voltage is only valid if the conditions $V_{\text{VIN}} > V_{\text{VIN,START}}$ and $V_{\text{VCP}} - V_{\text{VIN}} > V_{\text{VCP,UV,H}}$ and $V_{\text{VREG}} > V_{\text{VREG,UV,H}}$ are satisfied before V_{IN} is reduced.

ELECTRICAL CHARACTERISTICS – BUCK AND BUCK-BOOST PRE-REGULATOR SPECIFICATIONS¹: valid at 3.6 V ⁴ < V_{IN} < 36 V, $-40^{\circ}\text{C} < T_A = T_J < 150^{\circ}\text{C}$, unless otherwise specified.

Characteristic	Symbol	Test Conditions	Min.	Typ.	Max.	Unit
Output Voltage Specifications						
Buck Output Voltage – Regulating	V_{VREG}	$V_{VIN} = 13.5\text{ V}$, $ENB = 1$, $0.1\text{ A} < I_{VREG} < 1.25\text{ A}$	5.25	5.35	5.45	V
Pulse Width Modulation (PWM)						
PWM Ramp Offset	$PWM1_{OFFS}$	V_{COMP1} for 0% duty cycle	—	400	—	mV
LX1 Rising Slew Rate Control ²	$LX1_{RISE}$	$V_{VIN} = 13.5\text{ V}$, 10% to 90%, $I_{VREG} = 1\text{ A}$, $R_{SLEW} = 22.1\text{ k}$	—	0.9	—	V/ns
		$V_{VIN} = 13.5\text{ V}$, 10% to 90%, $I_{VREG} = 1\text{ A}$, $R_{SLEW} = 249\text{ k}$	—	0.3	—	
LX1 Falling Slew Rate ²	$LX1_{FALL}$	$V_{VIN} = 13.5\text{ V}$, 90% to 10%, $I_{VREG} = 1\text{ A}$	—	1.5	—	V/ns
Buck Min. Controllable ON-time	$t_{ON,MIN,BUCK}$		—	195	—	ns
Buck Maximum Duty Cycle	$D_{MAX,BUCK}$	$t_{OFF,BUCK} < 50\text{ ns}$	—	100	—	%
Boost Minimum OFF-time	$t_{ON,MIN,BST}$		—	100	130	ns
Boost Maximum Duty Cycle	$D_{MAX,BST}$	After $V_{VIN} > V_{IN,START}$, $V_{VIN} = 3.6\text{ V}$	—	65	—	%
COMP1 to LX1 Current Gain	gm_{POWER1}		—	4.5	—	A/V
Slope Compensation (2)	S_{E1}	$f_{OSC} = 2.0\text{ MHz}$	1.04	1.48	1.92	A/ μs
		$f_{OSC} = 400\text{ kHz}$	0.22	0.33	0.44	
Internal MOSFET						
MOSFET On Resistance	R_{DSon}	$V_{VIN} = 13.5\text{ V}$, $T_J = -40^{\circ}\text{C}$ ² , $I_{DS} = 0.1\text{ A}$	—	50	65	m Ω
		$V_{VIN} = 13.5\text{ V}$, $T_J = 25^{\circ}\text{C}$ ³ , $I_{DS} = 0.1\text{ A}$	—	75	90	m Ω
		$V_{VIN} = 13.5\text{ V}$, $T_J = 150^{\circ}\text{C}$, $I_{DS} = 0.1\text{ A}$	—	150	180	m Ω
MOSFET Leakage	$I_{FET,LKG}$	$V_{ENBATx} \leq 2.2\text{ V}$ and $V_{ENB} \leq 0.8\text{ V}$, $V_{LX1} = 0\text{ V}$, $V_{VIN} = 16\text{ V}$, $-40^{\circ}\text{C} < T_J < 85^{\circ}\text{C}$ ³	—	—	10	μA
		$V_{ENBATx} \leq 2.2\text{ V}$ and $V_{ENB} \leq 0.8\text{ V}$, $V_{LX1} = 0\text{ V}$, $V_{VIN} = 16\text{ V}$, $-40^{\circ}\text{C} < T_J < 150^{\circ}\text{C}$	—	50	150	μA
Error Amplifier						
Open Loop Voltage Gain	$AVOL1$		—	60	—	dB
Transconductance	gm_{EA1}	$V_{SS1} = 750\text{ mV}$	550	750	950	$\mu\text{A/V}$
		$V_{SS1} = 500\text{ mV}$	275	400	525	
Output Current	I_{EA1}		—	± 75	—	μA
Maximum Output Voltage	$EA1_{VO(max)}$		1.10	1.45	1.85	V
Minimum Output Voltage	$EA1_{VO(min)}$		—	—	300	mV
COMP1 Pull Down Resistance	R_{COMP1}	HICCUP1 = 1 or FAULT1 = 1 or $V_{ENBATx} \leq 2.2\text{ V}$ and $V_{ENB} \leq 0.8\text{ V}$, latched until $V_{SS1} < V_{SS1,RST}$	—	1	—	K Ω

¹ Negative current is defined as coming out of the node or pin (sourcing), positive current is defined as going into the node or pin (sinking).

² Ensured by design and characterization, not production tested.

³ Specifications at 25°C or 85°C are guaranteed by design and characterization, not production tested.

⁴ The lowest operating voltage is only valid if the conditions $V_{VIN} > V_{VIN,START}$ and $V_{VCP} - V_{VIN} > V_{VCP,UV,H}$ and $V_{VREG} > V_{VREG,UV,H}$ are satisfied before V_{IN} is reduced.

ELECTRICAL CHARACTERISTICS – BUCK AND BUCK-BOOST PRE-REGULATOR SPECIFICATIONS (continued)¹: valid at $3.6\text{ V} < V_{IN} < 36\text{ V}$, $-40^\circ\text{C} < T_A = T_J < 150^\circ\text{C}$, unless otherwise specified.

Characteristic	Symbol	Test Conditions	Min.	Typ.	Max.	Unit
Boost MOSFET (LG) Gate Driver						
LG High Output Voltage	$V_{LG,ON}$	$V_{VIN} = 6\text{ V}$, $V_{VREG} = 5.35\text{ V}$	4.6	—	5.5	V
LG Low Output Voltage	$V_{LG,OFF}$	$V_{VIN} = 13.5\text{ V}$, $V_{VREG} = 5.35\text{ V}$	—	0.2	0.4	V
LG Source Current ¹	$I_{LG,ON}$	$V_{VIN} = 6\text{ V}$, $V_{VREG} = 5.35\text{ V}$, $V_{LG} = 1\text{ V}$	—	-300	—	mA
LG Sink Current ¹	$I_{LG,OFF}$	$V_{VIN} = 13.5\text{ V}$, $V_{VREG} = 5.35\text{ V}$, $V_{LG} = 1\text{ V}$	—	150	—	mA
Soft Start						
SS1 Offset Voltage	$V_{SS1,OFFS}$	V_{SS1} rising due to $ISS1_{SU}$	—	400	—	mV
SS1 Fault/Hiccup Reset Voltage	$V_{SS1,RST}$	V_{SS1} falling due to $HICCUP1 = 1$ or $FAULT1 = 1$ or $V_{ENBATx} \leq 2.2\text{ V}$ and $V_{ENB} \leq 0.8\text{ V}$	140	200	275	mV
SS1 Startup (Source) Current	$ISS1_{SU}$	$V_{SS1} = 100\text{ mV}$, $HICCUP1 = FAULT1 = 0$	-10	-20	-30	μA
SS1 Hiccup (Sink) Current	$ISS1_{HIC}$	$V_{SS1} = 0.5\text{ V}$, $HICCUP1 = 1$	5	10	15	μA
SS1 Delay Time	$t_{SS1,DLY}$	$C_{SS1} = 22\text{ nF}$	—	440	—	μs
SS1 Ramp Time	t_{SS1}	$C_{SS1} = 22\text{ nF}$	—	880	—	μs
SS1 Pull Down Resistance	RPD_{SS1}	$FAULT1 = 1$ or $V_{ENBATx} \leq 2.2\text{ V}$ and $V_{ENB} \leq 0.8\text{ V}$, latched until $V_{SS1} < V_{SS1,RST}$	—	3	—	k Ω
SS1 PWM Frequency Foldback	$f_{SW1,SS}$	$V_{VREG} < 2.7 V_{TYP}$ & $V_{COMP1} = EA1_{VO(max)}$	—	$f_{osc}/4$	—	—
		$V_{VREG} < 2.7 V_{TYP}$	—	$f_{osc}/2$	—	—
		$V_{VREG} > 2.7 V_{TYP}$	—	f_{osc}	—	—
Hiccup Mode						
Hiccup1 OCP PWM Counts	$t_{HIC1,OCP}$	$V_{SS1} > V_{HIC1,EN}$, $V_{VREG} < 1.95 V_{TYP}$, $V_{COMP} = EA1_{VO(max)}$	—	30	—	PWM cycles
		$V_{SS1} > V_{HIC1,EN}$, $V_{VREG} > 1.95 V_{TYP}$, $V_{COMP} = EA1_{VO(max)}$	—	120	—	PWM cycles
Current Protections						
Pulse by pulse current limit	$I_{LIM1,ton(min)}$	$t_{ON} = t_{ON(MIN)}$	3.6	4.1	4.6	A
LX1 Short Circuit Current Limit	$I_{LIM,LX1}$	Latched OFF after 1 detection	7.5	10	—	A
Missing Asynchronous Diode (D1) Protection						
Detection Level	$V_{D,OPEN}$		-1.50	-1.30	-0.80	V
Time Filtering ²	$t_{D,OPEN}$		50	—	250	ns

¹ Negative current is defined as coming out of the node or pin (sourcing), positive current is defined as going into the node or pin (sinking).

² Ensured by design and characterization, not production tested.

³ Specifications at 25°C or 85°C are guaranteed by design and characterization, not production tested.

⁴ The lowest operating voltage is only valid if the conditions $V_{VIN} > V_{VIN,START}$ and $V_{VCP} - V_{VIN} > V_{CVP_{UV,H}}$ and $V_{VREG} > V_{VREG_{UV,H}}$ are satisfied before V_{IN} is reduced.

ELECTRICAL CHARACTERISTICS – 1.25 V SYNCHRONOUS BUCK REGULATOR¹: valid at $3.6\text{ V} < V_{\text{IN}} < 36\text{ V}$, $-40^{\circ}\text{C} < T_{\text{A}} = T_{\text{J}} < 150^{\circ}\text{C}$, unless otherwise specified.

Characteristic	Symbol	Test Conditions	Min.	Typ.	Max.	Unit
1V25 Output Voltage						
Output Voltage Accuracy	V_{1V25}	$50\text{ mA} < I_{1V25} < 750\text{ mA}$	1.23	1.25	1.27	V
Pulse Width Modulation (PWM)						
PWM Ramp Offset	$\text{PWM2}_{\text{OFFS}}$	V_{COMP2} for 0% duty cycle	–	350	–	mV
High-Side MOSFET Minimum ON-Time	$t_{\text{ON(MIN)}}$		–	65	105	ns
High-Side MOSFET Minimum OFF-Time	$t_{\text{OFF(MIN)}}$	Does not include total gate driver non-overlap time, t_{NO}	–	100	130	ns
Gate Driver Non-Overlap Time ²	t_{NO}		–	15	–	ns
COMP2 to LX2 Current gain	$\text{gm}_{\text{POWER2}}$		–	2.5	–	A/V
Slope Compensation ²	S_{E2}	$f_{\text{OSC}} = 2.0\text{ MHz}$	0.45	0.63	0.81	A/ μs
		$f_{\text{OSC}} = 400\text{ kHz}$	0.12	0.14	0.19	
Internal MOSFETs						
High-Side MOSFET ON Resistance	$\text{RDS}_{\text{ON (HS)}}$	$T_{\text{A}} = 25^{\circ}\text{C}$ ³ , $I_{\text{DS}} = 100\text{ mA}$	–	200	235	m Ω
		$I_{\text{DS}} = 100\text{ mA}$	–	–	400	m Ω
LX2 Node Rise/Fall Time ²	$t_{\text{R/F,LX2}}$	$V_{\text{VREG}} = 5.5\text{ V}$	–	12	–	ns
High-Side MOSFET Leakage ¹	$I_{\text{DSS (HS)}}$	$V_{\text{ENBATx}} \leq 2.2\text{ V}$ and $V_{\text{ENB}} \leq 0.8\text{ V}$, $V_{\text{LX2}} = 0\text{ V}$, $V_{\text{VREG}} = 5.5\text{ V}$, $-40^{\circ}\text{C} < T_{\text{J}} < 85^{\circ}\text{C}$ ³	–	–	2	μA
		$V_{\text{ENBATx}} \leq 2.2\text{ V}$ and $V_{\text{ENB}} \leq 0.8\text{ V}$, $V_{\text{LX2}} = 0\text{ V}$, $V_{\text{VREG}} = 5.5\text{ V}$, $-40^{\circ}\text{C} < T_{\text{J}} < 150^{\circ}\text{C}$	–	3	15	μA
Low-Side MOSFET ON Resistance	$\text{RDS}_{\text{ON (LS)}}$	$T_{\text{A}} = 25^{\circ}\text{C}$ ³ , $I_{\text{DS}} = 100\text{ mA}$	–	55	65	m Ω
		$I_{\text{DS}} = 100\text{ mA}$	–	–	110	m Ω
Low-Side MOSFET Leakage ¹	$I_{\text{DSS (LS)}}$	$V_{\text{ENBATx}} \leq 2.2\text{ V}$ and $V_{\text{ENB}} \leq 0.8\text{ V}$, $V_{\text{LX2}} = 5.5\text{ V}$, $-40^{\circ}\text{C} < T_{\text{J}} < 85^{\circ}\text{C}$ ³	–	–	1	μA
		$V_{\text{ENBATx}} \leq 2.2\text{ V}$ and $V_{\text{ENB}} \leq 0.8\text{ V}$, $V_{\text{LX2}} = 5.5\text{ V}$, $-40^{\circ}\text{C} < T_{\text{J}} < 150^{\circ}\text{C}$	–	8	20	μA

¹ Negative current is defined as coming out of the node or pin (sourcing), positive current is defined as going into the node or pin (sinking).

² Ensured by design and characterization, not production tested.

³ Specifications at 25°C or 85°C are guaranteed by design and characterization, not production tested.

⁴ The lowest operating voltage is only valid if the conditions $V_{\text{VIN}} > V_{\text{VIN,START}}$ and $V_{\text{VCP}} - V_{\text{VIN}} > V_{\text{VCP,UV,H}}$ and $V_{\text{VREG}} > V_{\text{VREG,UV,H}}$ are satisfied before V_{IN} is reduced.

ELECTRICAL CHARACTERISTICS – 1.25 V SYNCHRONOUS BUCK REGULATOR (continued)¹: valid at $3.6\text{ V} < V_{IN} < 36\text{ V}$, $-40^\circ\text{C} < T_A = T_J < 150^\circ\text{C}$, unless otherwise specified.

Characteristic	Symbol	Test Conditions	Min.	Typ.	Max.	Unit
1V25 Output Voltage						
Open Loop Voltage Gain ²	AVOL2		–	60	–	dB
Transconductance	g_{mEA2}	$I_{COMP2} = 0\ \mu\text{A}$, $V_{SS2} > 500\text{ mV}$	550	750	950	$\mu\text{A/V}$
		$0\text{ V} < V_{SS2} < 500\text{ mV}$	–	250	–	$\mu\text{A/V}$
Source & Sink Current	I_{EA2}	$V_{COMP2} = 1.5\text{ V}$	–	± 50	–	μA
Maximum Output Voltage	$EA2_{VO(max)}$		1.00	1.25	1.50	V
Minimum Output Voltage	$EA2_{VO(min)}$		–	–	150	mV
COMP2 Pull Down Resistance	R_{COMP2}	HICCUP2 = 1 or FAULT2 = 1 or $V_{ENBATx} \leq 2.2\text{ V}$ and $V_{ENB} \leq 0.8\text{ V}$, latched until $V_{SS2} < V_{SS2_{RST}}$	–	1.5	–	k Ω
Soft Start						
SS2 Offset Voltage	$V_{SS2_{OFFS}}$	V_{SS2} rising due to $ISS2_{SU}$	120	200	270	mV
SS2 Fault/Hiccup Reset Voltage	$V_{SS2_{RST}}$	V_{SS2} falling due to HICCUP2 = 1 or FAULT2 = 1 or $V_{ENBATx} \leq 2.2\text{ V}$ and $V_{ENB} \leq 0.8\text{ V}$	–	100	120	mV
SS2 Startup (Source) Current	$ISS2_{SU}$	$V_{SS2} = 1\text{ V}$, HICCUP2 = FAULT2 = 0	–10	–20	–30	μA
SS2 Hiccup (Sink) Current	$ISS2_{HIC}$	$V_{SS2} = 0.5\text{ V}$, HICCUP2 = 1	5	10	20	μA
SS2 to V_{1V2} Delay Time	$t_{SS2_{DLY}}$	$C_{SS2} = 10\text{ nF}$	–	100	–	μs
V_{1V2} Soft Start Ramp Time	t_{SS2}	$C_{SS2} = 10\text{ nF}$	–	400	–	μs
SS2 Pull Down Resistance	RPD_{SS2}	FAULT2 = 1 or $V_{ENBATx} \leq 2.2\text{ V}$ and $V_{ENB} \leq 0.8\text{ V}$, latched until $V_{SS2} < V_{SS2_{RST}}$	–	2	–	k Ω
SS2 PWM Frequency Foldback	$f_{SW2,SS}$	$V_{1V25} < 315\text{ mV}_{TYP}$	–	$f_{OSC}/4$	–	–
		$315\text{ mV}_{TYP} < V_{1V25} < 740\text{ mV}_{TYP}$	–	$f_{OSC}/2$	–	–
		$V_{1V25} > 740\text{ mV}_{TYP}$	–	f_{OSC}	–	–
Hiccup Mode						
Hiccup2 OCP Enable Threshold	$V_{HIC2,EN}$	V_{SS2} rising	–	1.2	–	V
Hiccup2 OCP Counts	$t_{HIC2,OCP}$	$V_{SS2} > V_{HIC2,EN}$, $V_{1V25} < 315\text{ mV}_{TYP}$	–	30	–	PWM cycles
		$V_{SS2} > V_{HIC2,EN}$, $V_{1V25} > 315\text{ mV}_{TYP}$	–	120	–	PWM cycles
Current Protections						
Pulse-by-Pulse Current Limit	$I_{LIM2,ton(min)}$	$t_{ON} = t_{ON(MIN)}$	1.8	2.1	2.4	A

¹ Negative current is defined as coming out of the node or pin (sourcing), positive current is defined as going into the node or pin (sinking).

² Ensured by design and characterization, not production tested.

³ Specifications at 25°C or 85°C are guaranteed by design and characterization, not production tested.

⁴ The lowest operating voltage is only valid if the conditions $V_{VIN} > V_{VIN,START}$ and $V_{VCP} - V_{VIN} > V_{VCP_{UV,H}}$ and $V_{VREG} > V_{VREG_{UV,H}}$ are satisfied before V_{IN} is reduced.

ELECTRICAL CHARACTERISTICS – LINEAR REGULATOR (LDO) SPECIFICATIONS 1: valid at $3.6\text{ V} < V_{IN} < 36\text{ V}$, $-40^\circ\text{C} < T_A = T_J < 150^\circ\text{C}$, unless otherwise specified.

Characteristic	Symbol	Test Conditions	Min.	Typ.	Max.	Unit
V5 and V5P Linear Regulators						
V5 Accuracy & Load Regulation	V_{V5}	$10\text{ mA} < I_{V5} < 155\text{ mA}$, $V_{VREG} = 5.25\text{ V}$	4.9	5.0	5.1	V
V5 Output Capacitance Range ²	$C_{OUT,V5}$		1.0	–	22	μF
V5P Accuracy & Load Regulation	V_{V5P}	$10\text{ mA} < I_{V5P} < 255\text{ mA}$, $V_{VREG} = 5.25\text{ V}$	4.9	5.0	5.1	V
V5P Output Capacitance ²	$C_{OUT,V5P}$		1.6	2.2	4.1	μF
V5 and V5P Minimum Output Voltage ²	$V_{V5x,MIN1}$	$V_{VCP} = 9\text{ V}$, TRACK = 1, $I_{V5} = 25\text{ mA}$, $I_{V5P} = 80\text{ mA}$, $I_{3V3} = 150\text{ mA}$, $I_{1V25} = 700\text{ mA}$ (192 mA to V_{VREG}) 1) $T_A = 150^\circ\text{C}$, $V_{VIN} = 5.12\text{ V}$, $V_{VREG} = 5.01\text{ V}$ 2) $T_A = -40^\circ\text{C}$, $V_{VIN} = 5.12\text{ V}$, $V_{VREG} = 5.06\text{ V}$	4.85	–	–	V
	$V_{V5x,MIN2}$	$V_{VCP} = 8.5\text{ V}$, TRACK = 1, $I_{V5} = 25\text{ mA}$, $I_{V5P} = 80\text{ mA}$, $I_{3V3} = 150\text{ mA}$, $I_{1V25} = 700\text{ mA}$ (213 mA to V_{VREG}) 1) $T_A = 150^\circ\text{C}$, $V_{VIN} = 4.50\text{ V}$, $V_{VREG} = 4.39\text{ V}$ 2) $T_A = -40^\circ\text{C}$, $V_{VIN} = 4.50\text{ V}$, $V_{VREG} = 4.44\text{ V}$	4.25	–	–	
V5P Tracking						
V5P/3V3 Tracking Ratio		$V_{V5P} \div V_{3V3}$	1.505	1.515	1.525	–
V5P/3V3 Tracking Accuracy	$TRACK_{3V3}$	$3.0\text{ V} < V_{3V3} < 3.3\text{ V}$, TRACK = 1, $I_{3V3} = I_{V5P} = 75\text{ mA}$	–0.66	–	+0.66	%
V5P/V5 Tracking Accuracy	$TRACK_{V5}$	$3.5\text{ V} < V_{V5} < 5.0\text{ V}$, TRACK = 0, $I_{V5P} = I_{V5} = 75\text{ mA}$	–35	–	+35	mV
V5P Over Current Protection						
V5P Current Limit ¹	$V5P_{ILIM}$	$V_{V5P} = 5\text{ V}$	–285	–400	–	mA
V5P Foldback Current ¹	$V5P_{IFBK}$	$V_{V5P} = 0\text{ V}$	–60	–115	–170	mA
V5 Over Current Protection						
V5 Current Limit ¹	$V5_{ILIM}$	$V_{V5} = 5\text{ V}$	–175	–245	–	mA
V5 Foldback Current ¹	$V5_{IFBK}$	$V_{V5} = 0\text{ V}$	–35	–70	–105	mA
V5P & V5 Startup Timing						
V5P Startup Time ²		$C_{V5P} \leq 2.9\text{ }\mu\text{F}$, Load = $25\text{ }\Omega \pm 5\%$ (200 mA)	–	0.17	0.60	ms
V5 Startup Time ²		$C_{V5} \leq 2.9\text{ }\mu\text{F}$, Load = $33\text{ }\Omega \pm 5\%$ (150 mA)	–	0.24	1.0	ms

¹ Negative current is defined as coming out of the node or pin (sourcing), positive current is defined as going into the node or pin (sinking).

² Ensured by design and characterization, not production tested.

³ Specifications at 25°C or 85°C are guaranteed by design and characterization, not production tested.

⁴ The lowest operating voltage is only valid if the conditions $V_{VIN} > V_{VIN,START}$ and $V_{VCP} - V_{VIN} > V_{CP,UV,H}$ and $V_{VREG} > V_{REG,UV,H}$ are satisfied before V_{IN} is reduced.

ELECTRICAL CHARACTERISTICS – CONTROL INPUTS ¹: valid at $3.6\text{ V} < V_{IN} < 36\text{ V}$, $-40^\circ\text{C} < T_A = T_J < 150^\circ\text{C}$, unless otherwise specified.

Characteristic	Symbol	Test Conditions	Min.	Typ.	Max.	Unit
3V3 Linear Regulator						
3V3 Accuracy & Load Regulation	V_{3V3}	$10\text{ mA} < I_{3V3} < 165\text{ mA}$, $V_{VREG} = 5.25\text{ V}$	3.23	3.30	3.37	V
3V3 Output Capacitance Range ²	$C_{OUT,3V3}$		1.0	–	22	μF
3V3 Minimum Output Voltage ²	$V_{3V3,MIN1}$	$V_{VCP} = 9\text{ V}$, TRACK = 1, $I_{V5} = 25\text{ mA}$, $I_{V5P} = 80\text{ mA}$, $I_{3V3} = 150\text{ mA}$, $I_{1V25} = 700\text{ mA}$ (192 mA to VREG) 1) $T_A = 150^\circ\text{C}$, $V_{VIN} = 5.12\text{ V}$, $V_{VREG} = 5.01\text{ V}$ 2) $T_A = -40^\circ\text{C}$ ² , $V_{VIN} = 5.12\text{ V}$, $V_{VREG} = 5.06\text{ V}$	3.23	3.30	–	V
	$V_{3V3,MIN2}$	$V_{VCP} = 8.5\text{ V}$, TRACK = 1, $I_{V5} = 25\text{ mA}$, $I_{V5P} = 80\text{ mA}$, $I_{3V3} = 150\text{ mA}$, $I_{1V25} = 700\text{ mA}$ (213 mA to VREG) 1) $T_A = 150^\circ\text{C}$, $V_{VIN} = 4.50\text{ V}$, $V_{VREG} = 4.39\text{ V}$ 2) $T_A = -40^\circ\text{C}$ ² , $V_{VIN} = 4.50\text{ V}$, $V_{VREG} = 4.44\text{ V}$	3.15	3.30	–	
3V3 Over Current Protection						
3V3 Current Limit ¹	$3V3_{ILIM}$	$V_{3V3} = 3.3\text{ V}$	–185	–260	–	mA
3V3 Foldback Current ¹	$3V3_{IFBK}$	$V_{3V3} = 0\text{ V}$	–40	–75	–130	mA
3V3 Startup Timing						
3V3 Startup Time ²		$C_{3V3} \leq 2.9\text{ }\mu\text{F}$, Load = $33\text{ }\Omega \pm 5\%$ (100 mA)	–	0.17	0.55	ms
Ignition Enable (ENBAT1 and ENBAT2) Inputs						
ENBAT1, ENBAT2 Thresholds	$V_{ENBATx,H}$	V_{ENBATx} rising	2.9	3.3	3.5	V
	$V_{ENBATx,L}$	V_{ENBATx} falling	2.2	2.6	2.9	V
ENBAT1, ENBAT2 Hysteresis	$V_{ENBATx,HYS}$	$V_{ENBATx,H} - V_{ENBATx,L}$	–	700	–	mV
ENBAT1, ENBAT2 Bias Current ¹	$I_{ENBATx,BIAS}$	$T_J = 25^\circ\text{C}$ ³ , $V_{ENBATx} = 3.51\text{ V}$	–	28	45	μA
		$T_J = 150^\circ\text{C}$, $V_{ENBATx} = 3.51\text{ V}$	–	35	55	
ENBAT1, ENBAT2 Pull-Down Resistance	R_{ENBATx}	$V_{ENBATx} < 1.2\text{ V}$	–	650	–	k Ω
Logic Enable (ENB) Input						
ENB Thresholds	$V_{ENB,H}$	V_{ENB} rising	–	–	2.0	V
	$V_{ENB,L}$	V_{ENB} falling	0.8	–	–	V
ENB Bias Current ¹	$I_{ENB,IN}$	$V_{ENB} = 3.3\text{ V}$	–	–	175	μA
ENB Resistance	R_{ENB}		–	60	–	k Ω
ENB/ENBATx Filter/Deglintch						
Enable Filter/Deglintch Time	$EN_{td,FILT}$		10	15	20	μs
ENB/ENBATx Shutdown Delay						
LDO Shutdown Delay	$td_{LDO,OFF}$	Measure $td_{LDO,OFF}$ from the falling edge of ENB and ENBAT1 and ENBAT2 to the time when all LDOs begin to decay	15	50	100	μs

¹ Negative current is defined as coming out of the node or pin (sourcing), positive current is defined as going into the node or pin (sinking).

² Ensured by design and characterization, not production tested.

³ Specifications at 25°C or 85°C are guaranteed by design and characterization, not production tested.

⁴ The lowest operating voltage is only valid if the conditions $V_{VIN} > V_{VIN,START}$ and $V_{VCP} - V_{VIN} > V_{VCP,UV,H}$ and $V_{VREG} > V_{VREG,UV,H}$ are satisfied before V_{IN} is reduced.

ELECTRICAL CHARACTERISTICS – CONTROL INPUTS (continued) ¹: valid at $3.6\text{ V} < V_{IN} < 36\text{ V}$, $-40^{\circ}\text{C} < T_A = T_J < 150^{\circ}\text{C}$, unless otherwise specified.

Characteristic	Symbol	Test Conditions	Min.	Typ.	Max.	Unit
TRACK Input						
TRACK Thresholds	V_{T_H}	V_{TRACK} rising	–	–	2.0	V
	V_{T_L}	V_{TRACK} falling	0.8	–	–	V
TRACK Bias Current ¹	I_{B_T}		–	–100	–	μA
FSET/SYNC Input						
FSET/SYNC Pin Voltage	$V_{FSET/SYNC}$	No external SYNC signal	–	800	–	mV
FSET/SYNC Open Circuit (Under Current) Detection Time	$V_{FSET/SYNC,UC}$	PWM switching disabled upon detection	–	3	–	μs
FSET/SYNC Short Circuit (Over Current) Detection Time	$V_{FSET/SYNC,OC}$	PWM switching disabled upon detection	–	3	–	μs
Sync. High Threshold	$SYNC_{VIH}$	V_{SYNC} rising	–	–	2.0	V
Sync. Low Threshold	$SYNC_{VIL}$	V_{SYNC} falling	0.5	–	–	V
Sync. Input Duty Cycle	DC_{SYNC}		–	–	80	%
Sync. Input Pulse Width	tw_{SYNC}		200	–	–	ns
Sync. Input Transition Times ²	tt_{SYNC}		–	10	15	ns
SLEW Input						
SLEW Pin Operating Voltage	V_{SLEW}		–	800	–	mV
SLEW Pin Open Circuit (Under Current) Detection Time	$V_{SLEW,UC}$	PWM latched off upon detection	–	3	–	μs
SLEW Pin Short Circuit (Over Current) Detection Time	$V_{SLEW,OC}$	PWM latched off upon detection	–	3	–	μs
SLEW Bias Current ¹	I_{SLEW}		–	–100	–	nA

¹ Negative current is defined as coming out of the node or pin (sourcing), positive current is defined as going into the node or pin (sinking).² Ensured by design and characterization, not production tested.³ Specifications at 25°C or 85°C are guaranteed by design and characterization, not production tested.⁴ The lowest operating voltage is only valid if the conditions $V_{VIN} > V_{VIN,START}$ and $V_{VCP} - V_{VIN} > V_{CP_{UV,H}}$ and $V_{VREG} > V_{REG_{UV,H}}$ are satisfied before V_{IN} is reduced.

ELECTRICAL CHARACTERISTICS – DIAGNOSTIC OUTPUTS ¹: valid at $3.6\text{ V} < V_{IN} < 36\text{ V}$, $-40^{\circ}\text{C} < T_A = T_J < 150^{\circ}\text{C}$, unless otherwise specified.

Characteristic	Symbol	Test Conditions	Min.	Typ.	Max.	Unit
NPOR OV/UV Protection Thresholds						
3V3 OV Thresholds	$V_{3V3,OV,H}$	V_{3V3} rising	3.41	3.51	3.60	V
	$V_{3V3,OV,L}$	V_{3V3} falling	–	3.49	–	
3V3 OV Hysteresis	$V_{3V3,OV,HYS}$	$V_{3V3,OV,H} - V_{3V3,OV,L}$	10	20	40	mV
3V3 UV Thresholds	$V_{3V3,UV,H}$	V_{3V3} rising	–	3.12	–	V
	$V_{3V3,UV,L}$	V_{3V3} falling	3.00	3.10	3.19	
3V3 UV Hysteresis	$V_{3V3,UV,HYS}$	$V_{3V3,UV,H} - V_{3V3,UV,L}$	10	20	40	mV
1V25 OV Thresholds	$V_{1V25,OV,H}$	V_{1V25} rising	1.29	1.32	1.35	V
	$V_{1V25,OV,L}$	V_{1V25} falling	–	1.31	–	
1V25 OV Hysteresis	$V_{3V3,OV,HYS}$	$V_{1V25,OV,H} - V_{1V25,OV,L}$	5	10	20	mV
1V25 UV Thresholds	$V_{1V25,UV,H}$	V_{1V25} rising, triggers turn on of LDOs	–	1.19	–	V
	$V_{1V25,UV,L}$	V_{1V25} falling	1.15	1.18	1.21	
1V25 UV Hysteresis	$V_{3V3,UV,HYS}$	$V_{1V25,UV,H} - V_{1V25,UV,L}$	5	10	20	mV
NPOR Turn-on and Turn-off Delays						
NPOR Turn-on Delay	$td_{NPOR,ON}$		12	15	18	ms
NPOR Turn-off Propagation Delay	$td_{NPOR,OFF}$	ENB and ENBAT1 and ENBAT2 low to NPOR low	–	15	23	μs
NPOR Output Voltages						
NPOR Output Low Voltage	$V_{NPOR,L}$	ENB or ENBAT1 or ENBAT2 high, $V_{IN} \geq 2.5\text{ V}$, $I_{NPOR} = 4\text{ mA}$	–	150	400	mV
		ENB or ENBAT1 or ENBAT2 high, $V_{IN} = 1.5\text{ V}$, $I_{NPOR} = 2\text{ mA}$	–	–	800	
NPOR Leakage Current ¹	$I_{NPOR,LKG}$	$V_{NPOR} = 3.3\text{ V}$	–	–	2	μA
NPOR and POK5V OV Delay Time						
Over Voltage Detection Delay	td_{OV}	V5P, V5, 3V3, and 1V25 over voltage detection delay time, $WD_{ENn} = 0$	6.40	8.00	9.60	ms
NPOR and POK5V UV Filtering/Deglitch						
UV Filter/Deglitch Times	td_{FILT}	Applies to under-voltage of the 3V3, 1V25, V5, and V5P voltages	10	15	20	μs

¹ Negative current is defined as coming out of the node or pin (sourcing), positive current is defined as going into the node or pin (sinking).

² Ensured by design and characterization, not production tested.

³ Specifications at 25°C or 85°C are guaranteed by design and characterization, not production tested.

⁴ The lowest operating voltage is only valid if the conditions $V_{VIN} > V_{VIN,START}$ and $V_{VCP} - V_{VIN} > V_{VCP,UV,H}$ and $V_{VREG} > V_{VREG,UV,H}$ are satisfied before V_{IN} is reduced.

ELECTRICAL CHARACTERISTICS – DIAGNOSTIC OUTPUTS (continued) ¹: valid at $3.6\text{ V} < V_{IN} < 36\text{ V}$, $-40^{\circ}\text{C} < T_A = T_J < 150^{\circ}\text{C}$, unless otherwise specified.

Characteristic	Symbol	Test Conditions	Min.	Typ.	Max.	Unit
POK5V OV/UV Protection Thresholds						
V5 OV Thresholds	$V_{V5,OV,H}$	V_{V5} rising	5.15	5.33	5.50	V
	$V_{V5,OV,L}$	V_{V5} falling	–	5.30	–	
V5 OV Hysteresis	$V_{V5,OV,HYS}$	$V_{V5,OV,H} - V_{V5,OV,L}$	15	30	50	mV
V5 UV Thresholds	$V_{V5,UV,H}$	V_{V5} rising	–	4.71	–	V
	$V_{V5,UV,L}$	V_{V5} falling	4.50	4.68	4.85	
V5 UV Hysteresis	$V_{V5,UV,HYS}$	$V_{V5,UV,H} - V_{V5,UV,L}$	15	30	50	mV
V5P Output Disconnect Threshold	$V_{V5P,DISC}$	V_{V5P} rising	–	7.2	–	V
V5P OV Thresholds	$V_{V5P,OV,H}$	V_{V5P} rising	5.15	5.33	5.50	V
	$V_{V5P,OV,L}$	V_{V5P} falling	–	5.30	–	
V5P OV Hysteresis	$V_{V5P,OV,HYS}$	$V_{V5P,OV,H} - V_{V5P,OV,L}$	15	30	50	mV
V5P UV Thresholds	$V_{V5P,UV,H}$	V_{V5P} rising	–	4.71	–	V
	$V_{V5P,UV,L}$	V_{V5P} falling	4.50	4.68	4.85	
V5P UV Hysteresis	$V_{V5P,UV,HYS}$	$V_{V5P,UV,H} - V_{V5P,UV,L}$	15	30	50	mV
POK5V Output Voltages						
POK5V Output Voltage	$V_{POK5V,L}$	ENB = 1 or ENBAT1 = 1 or ENBAT2 = 1, $V_{VIN} \geq 2.5\text{ V}$, $I_{POK5V} = 4\text{ mA}$	–	150	400	mV
		ENB = 1 or ENBAT1 = 1, ENBAT2 = 1, $V_{VIN} = 1.5\text{ V}$, $I_{POK5V} = 2\text{ mA}$	–	–	800	
POK5V Leakage Current	$I_{POK5V,LKG}$	$V_{POK5V} = 3.3\text{ V}$	–	–	2	μA
VREG, VCP, and BG Thresholds						
VREG OV Thresholds	$V_{VREG,OV,H}$	V_{VREG} rising, LX1 PWM disabled	5.70	5.95	6.20	V
	$V_{VREG,OV,L}$	V_{VREG} falling, LX1 PWM enabled	–	5.85	–	
VREG OV Hysteresis	$V_{VREG,OV,HYS}$	$V_{VREG,OV,H} - V_{VREG,OV,L}$	–	100	–	mV
VREG UV Thresholds	$V_{VREG,UV,H}$	V_{VREG} rising, triggers rise of SS2	4.14	4.38	4.62	V
	$V_{VREG,UV,L}$	V_{VREG} falling	–	4.28	–	
VREG UV Hysteresis	$V_{VREG,UV,HYS}$	$V_{VREG,UV,H} - V_{VREG,UV,L}$	–	100	–	mV
VCP OV Thresholds	$V_{VCP,OV,H}$	V_{VCP} rising, latches all regulators off	11.0	12.5	14.0	V
VCP UV Thresholds	$V_{VCP,UV,H}$	V_{VCP} rising, PWM enabled	2.95	3.15	3.35	V
	$V_{VCP,UV,L}$	V_{VCP} falling, PWM disabled	–	2.8	–	
VCP UV Hysteresis	$V_{VCP,UV,HYS}$	$V_{VCP,UV,H} - V_{VCP,UV,L}$	–	350	–	mV
BGREF & BGFAULT UV Thresholds ²	$BG_{X,UV}$	BG_{VREF} or BG_{FAULT} rising	1.00	1.05	1.10	V
Ignition Status (ENBAT1S and ENBAT2S)						
ENBATxS Thresholds	$V_{ENBATxS,H}$	V_{ENBATx} rising	2.9	3.3	3.5	V
	$V_{ENBATxS,L}$	V_{ENBATx} falling	2.2	2.6	2.9	V
ENBATxS Output Voltage	$V_{O,ENBATxS,LO}$	$I_{ENBATxS} = 4\text{ mA}$	–	–	400	mV
ENBATxS Leakage Current (1)	$I_{ENBATxS}$	$V_{ENBATxS} = 3.3\text{ V}$	–	–	1	μA

¹ Negative current is defined as coming out of the node or pin (sourcing), positive current is defined as going into the node or pin (sinking).

² Ensured by design and characterization, not production tested.

³ Specifications at 25°C or 85°C are guaranteed by design and characterization, not production tested.

⁴ The lowest operating voltage is only valid if the conditions $V_{VIN} > V_{VIN,START}$ and $V_{VCP} - V_{VIN} > V_{VCP,UV,H}$ and $V_{VREG} > V_{VREG,UV,H}$ are satisfied before V_{IN} is reduced.

ELECTRICAL CHARACTERISTICS – WINDOW WATCHDOG TIMER (WWDT) ¹: valid at $3.6\text{ V} < V_{\text{IN}} < 36\text{ V}$, $-40^{\circ}\text{C} < T_{\text{A}} = T_{\text{J}} < 150^{\circ}\text{C}$, unless otherwise specified.

Characteristic	Symbol	Test Conditions	Min.	Typ.	Max.	Unit
WD Enable_n Input (WDEN_n)						
WD _{ENn} Voltage Thresholds	WD _{ENn,LO}	V _{WDENn} falling, WDT enabled	0.8	–	–	V
	WD _{ENn,HI}	V _{WDENn} rising, WDT disabled	–	–	2.0	V
WD _{ENn} Input Resistance	R _{WD,ENn}		–	60	–	kΩ
WD_{IN} Voltage Thresholds & Current						
WD _{IN} Input Voltage Thresholds	WD _{IN,LO}	V _{WD,IN} falling, WD _{ADJ} pulled low by R _{ADJ}	0.8	–	–	V
	WD _{IN,HI}	V _{WD,IN} rising, WD _{ADJ} charging	–	–	2.0	V
WD _{IN} Input Current ¹	WD _{I,IN}	V _{WD,IN} = 5 V	–10	±1	10	μA
WD_{IN} Timing Specifications						
WD _{IN} Frequency	WD _{IN,FREQ}		–	–	750	Hz
WD _{IN} Duty Cycle	WD _{IN,DUTY}		20	50	80	%
Watchdog Activation Delay	WD _{START,DLY}		24	30	36	ms
WD Programming (WD_{ADJ})						
WD Timeout FAST Range ²			1.0	–	25	ms
WD Timeout SLOW Range ²	—		4.0	–	100	ms
WD Timeout, FAST Clock	WD _{TO,FAST}	R _{ADJ} = 13 kΩ	0.8	1.0	1.2	ms
		R _{ADJ} = 324 kΩ	20	25	30	
WD Timeout, SLOW Clock	WD _{TO,SLOW}	R _{ADJ} = 13 kΩ	3.2	4.0	4.8	ms
		R _{ADJ} = 324 kΩ	80	100	120	
WD One-Shot Time						
WD Pulse Time after a WD Fault	t _{WD,FAULT}		1.6	2.0	2.4	ms

¹ Negative current is defined as coming out of the node or pin (sourcing), positive current is defined as going into the node or pin (sinking).

² Ensured by design and characterization, not production tested.

³ Specifications at 25°C or 85°C are guaranteed by design and characterization, not production tested.

⁴ The lowest operating voltage is only valid if the conditions $V_{\text{VIN}} > V_{\text{VIN,START}}$ and $V_{\text{VCP}} - V_{\text{VIN}} > V_{\text{VCP,UV,H}}$ and $V_{\text{VREG}} > V_{\text{VREG,UV,H}}$ are satisfied before VIN is reduced.

FUNCTIONAL DESCRIPTION

Overview

The A4410 is a power management IC designed for automotive applications. It contains a pre-regulator plus four DC post regulators to create the voltages necessary for typical automotive applications such as electrical power steering and automatic transmission control.

The pre-regulator can be configured as a buck or buck boost regulator. Buck boost is required for applications that need to work with extremely low battery voltages. This pre-regulator generates a fixed 5.35 V and can deliver up to 1.2 A to power the internal or external post-regulators. These post-regulators generate the various voltage levels for the end system.

The A4410 includes four internal post regulators; three linear regulators and one fixed output synchronous buck regulator.

Buck-Boost Pre-Regulator (VREG)

The pre-regulator incorporates an internal high side buck switch and a boost switch gate driver. An external freewheeling diode and LC filter are required to complete the buck converter. By adding a MOSFET and boost diode the boost functionality can maintain all outputs with input voltages down to 2.8 V. The A4410 includes a compensation pin (COMP1) and a soft-start pin (SS1) for the pre-regulator.

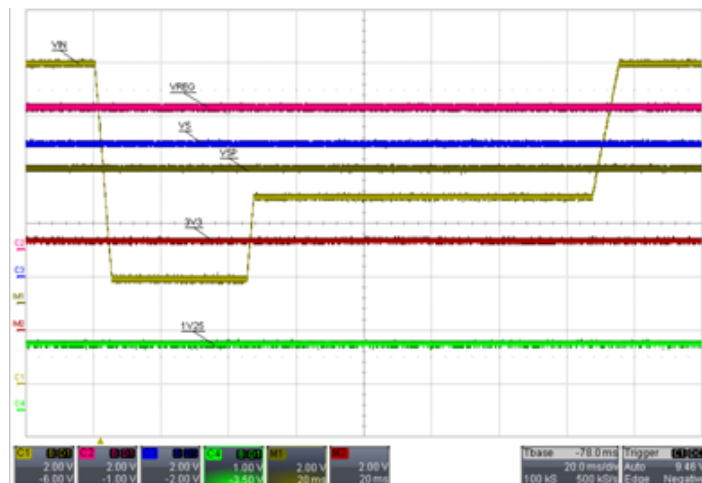

Figure 1: Performance for Representative VIN Start/Stop Transients

$V_{IN_TYP} = 12\text{ V}$, $V_{IN_MIN} = 4\text{ V}$, 20 ms/DIV

The pre-regulator provides protection and diagnostic functions.

1. Over voltage protection
2. High voltage rating for load dump
3. Switch node to ground short circuit protection
4. Open freewheeling diode protection
5. Pulse-by-pulse current limit
6. Hiccup mode short circuit protection (shown below)

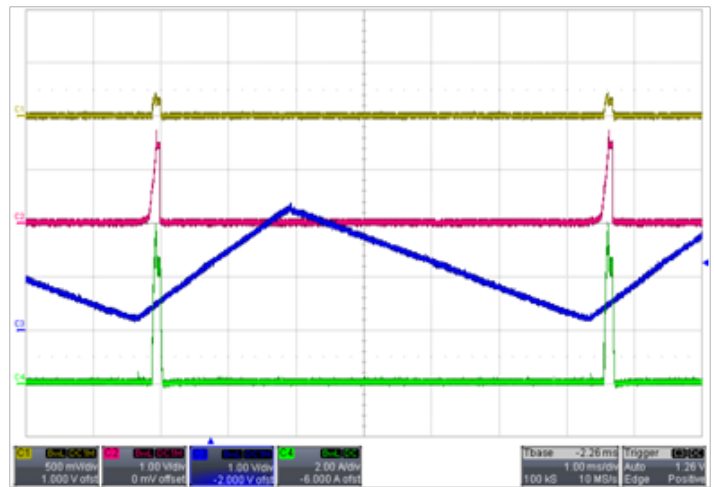

Figure 2: Pre-regulator Hiccup Mode when VREG is Shorted to GND

CH1 = VREG, CH2 = COMP1, CH3 = SS1, CH4 = I_{L1} , 1 ms/DIV

Synchronous Buck Regulator (1V25)

The A4410 integrates the high-side and low-side MOSFETs necessary for implementing a 1.25 V/750 mA_{DC}/1 A_{PEAK} synchronous buck regulator. The synchronous buck is powered by the 5.35 V pre-regulator output. An LC filter is required to complete the synchronous buck regulator. The A4410 includes a compensation pin (COMP2) and a soft-start pin (SS2) for the synchronous buck.

Protection and safety functions provided by the synchronous buck are:

1. Under voltage detection
2. Over voltage detection
3. Switch node to ground short circuit protection
4. Pulse-by-pulse current limit
5. Hiccup mode short circuit protection (shown below)

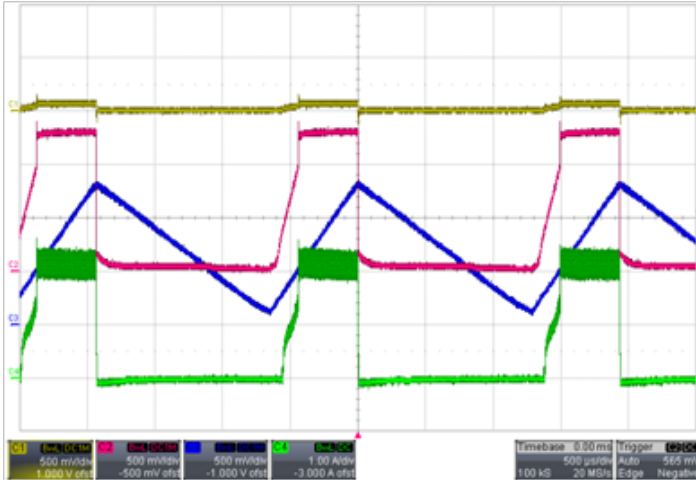

Figure 3: Synchronous Buck Hiccup Mode when V_{OUT} is Shorted to GND

CH1= V_{OUT} , CH2=COMP1, CH3=SS1, CH4=IL1, 500 μ s/DIV

Low Dropout Linear Regulators (LDOs)

The A4410 has three low dropout linear regulators (LDOs), one 3.3 V/160 mA_{MAX} (3V3), one 5 V/150 mA_{MAX} (V5), and one high-voltage protected 5 V/250 mA_{MAX} (V5P). The switching pre-regulator efficiently regulates the battery voltage to an intermediate value to power the LDOs. This pre-regulator topology reduces LDO power dissipation and junction temperature.

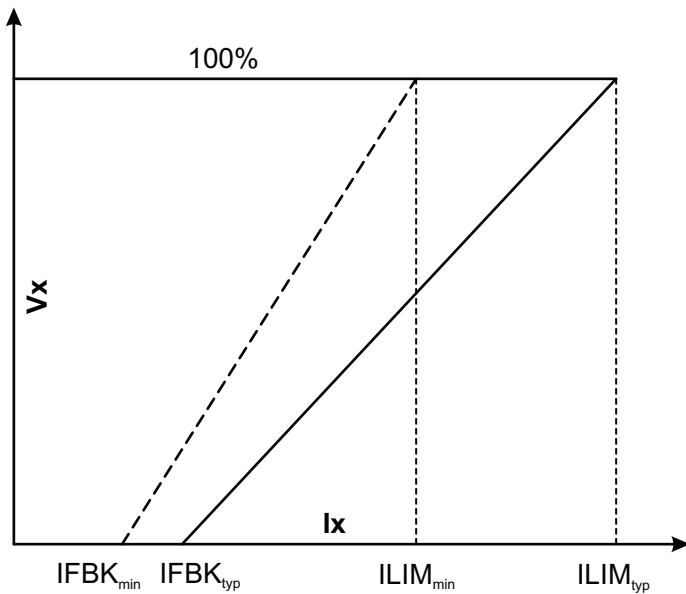

Figure 4: LDO Foldback Protection

All linear regulators provide the following protection features;

1. Under voltage and over voltage detection
2. Current limit with fold back short circuit protection

The protected 5 V regulator (V5P) includes protection against accidental short circuit to the battery voltage. This makes this output most suitable for powering remote sensors or circuitry via a wiring harness where short to battery is possible.

Tracking Input (TRACK)

The V5P LDO is a tracking regulator. It can be set to use either V5 or 3V3 as its reference by setting the TRACK input pin to a logic low or high. If the TRACK input is left unconnected an internal current source will set the TRACK pin to a logic high.

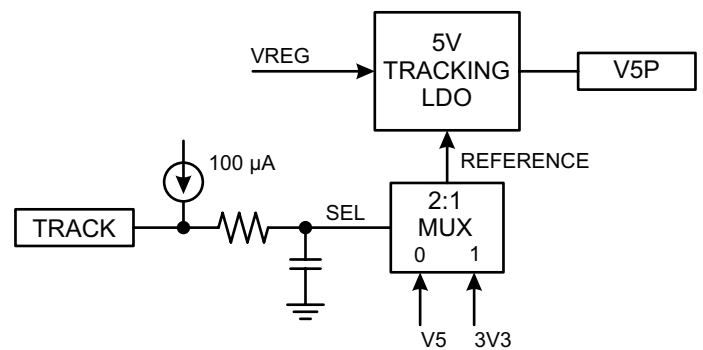

Figure 5: TRACK Input Circuit

Window Watchdog Timer (WDT)

The A4410s window watchdog circuit monitors an external clock applied to the WD_{IN} pin. This clock should be generated by the micro-controller or DSP. The time between rising edges of the clock must fall within an acceptable “window” or a watchdog fault is generated. A watchdog fault will set NPOR for $t_{WD,FAULT}$ (typically 2 ms). A watchdog fault will occur if the time between rising edges is either too short (a FAST fault) or too long (a SLOW fault).

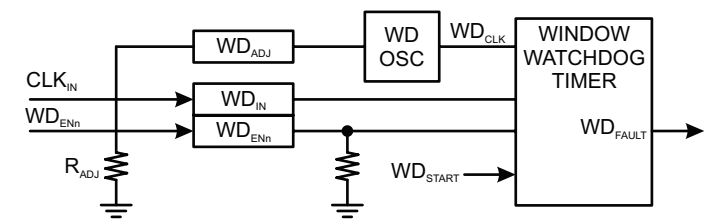

Figure 6: Window Watchdog Timer

The watchdogs time “window” is programmable via the WD_{ADJ} pin according to the following equations:

$$R_{ADJ} = 3.240 * WD_{TO,SLOW}$$

$$WD_{TO,FAST} = WD_{TO,SLOW} / 4$$

Where $WD_{TO,SLOW}$ is the nominal watchdog timeout (in ms) and R_{ADJ} is the required external resistor value (in $k\Omega$) from the WD_{ADJ} pin to ground. Typical watchdog operation and FAST and SLOW fault conditions are shown in Figures 13a and 13b.

The watchdog is enabled if two conditions are met: (1) the WD_{ENH} pin is a logic low and (2) all the regulators (1V25, 3V3, V5, and V5P) have been above their under voltage thresholds for at least $30 ms_{TYP}$ ($WD_{START,DLY}$).

After startup, if no clock edges are detected at WD_{IN} for at least $WD_{START,DLY} + WD_{TO,SLOW}$ the A4410 will set NPOR low for $t_{WD,FAULT}$ and reset its counters. This process will repeat until the system recovers and clock edges are applied to WD_{IN} . A timing diagram for the “missing clock” situation is shown in Figure 13c.

Dual Band Gaps (BG_{VREF} , BG_{FAULT})

Dual band gaps, or references, are implemented within the A4410. One band gap (BG_{VREF}) is dedicated solely to closed loop control of the output voltages. The second band gap (BG_{FAULT}) is employed for fault monitoring functions. Having redundant band gaps improves reliability of the A4410.

If the reference band gap is out of specification (BG_{VREF}) then the output voltages will be out of specification and the monitoring band gap will report a fault condition by setting NPOR and/or POK5V low.

If the monitoring band gap is out of specification (BG_{FAULT}) then the outputs will remain in regulation but the monitoring circuits will report a fault condition by setting NPOR and/or POK5V low.

The reference and monitoring band gap circuits include two, smaller secondary band gaps that are used to detect under voltage of the main band gaps during power-up.

Adjustable Frequency and Synchronization (FSET/SYNC)

The PWM switching frequency of the A4410 is adjustable from 250 kHz to 2.4 MHz. Connecting a resistor from the FSET/SYNC pin to ground sets the switching frequency. An FSET resistor with $\pm 1\%$ tolerance is recommended. The FSET resistor can be calculated using the following equation:

$$R_{FSET} = \left(\frac{f_{OSC}}{12724} \right)^{-1.175}$$

Where R_{FSET} is in $k\Omega$ and f_{OSC} is the desired oscillator (PWM) frequency in kHz.

A graph of switching frequency versus FSET resistor values is shown below.

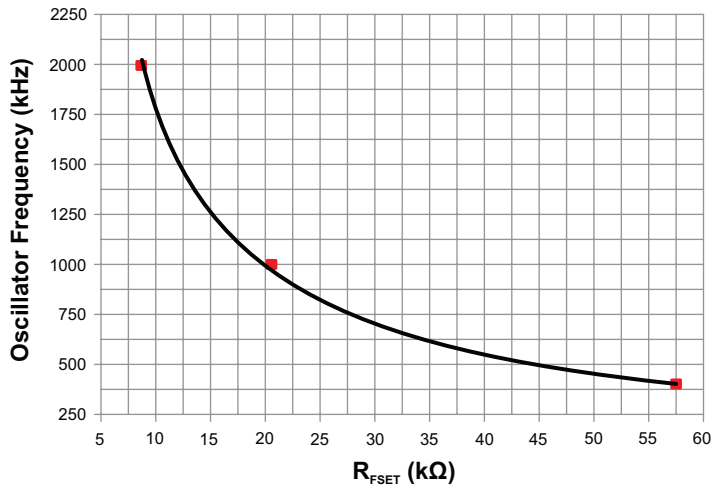

Figure 7: Switching Frequency vs. FSET Resistor Values

The PWM frequency of the A4410 may be increased or decreased by applying a clock to the FSET/SYNC pin. The clock must satisfy the voltage thresholds and timing requirements shown in the electrical characteristics table.

Frequency Dithering and LX1 Slew Rate Control

The A4410 includes two innovative techniques to help reduce EMI/EMC for demanding automotive applications.

First, the A4410 performs pseudo-random dithering of the PWM frequency. Dithering the PWM frequency spreads the energy above and below the base frequency set by R_{FSET} . A typical fixed-frequency PWM regulator will create distinct “spikes” of energy at f_{OSC} , and at higher frequency multiples of f_{OSC} . Conversely, the A4410 spreads the spectrum around f_{OSC} thus creating a lower magnitude at any comparative frequency. Frequency dithering is disabled if SYNC is used or VIN drops below approximately 8.3 V.

Second, the A4410 includes a pin to adjust the turn on slew rate of the LX1 pin by simply changing the value of the resistor from the SLEW pin to ground. Slower rise times of LX1 reduce ringing and high frequency harmonics of the regulator. The rise time may be adjusted to be quite long and will increase thermal dissipation of the pre-regulator if set too slow. Typical values of rise time versus R_{SLEW} are

Table 1: R_{SLEW} vs. Rise Time

R_{SLEW} (k Ω)	LX1 Rise Time (ns)
8.66	7
44.2	11
100	20

Enable Inputs (ENB, ENBAT1, ENBAT2)

Three enable pins are available on the A4410. A high signal on any of these pins enables the A4410. One enable (ENB) is logic level compatible for micro-controller control. The other inputs (ENBAT1 and ENBAT2) must be connected to the ignition (IGN) or accessory (ACC) switch through a relatively low value series resistance, 2 k Ω – 3.6 k Ω . For transient suppression it is recommended that a 0.1 μ F – 0.22 μ F capacitor be placed after the series resistance to form a low pass filter for the ENBAT1 and ENBAT2 pins as shown in the Applications Schematic.

Bias Supply (VCC)

The bias supply (VCC) is generated by an internal linear regulator. This supply is the first rail to start up. Most of the internal control circuitry is powered by this supply. The bias supply includes some unique features to ensure reliable operation of the A4410. These features include;

1. Input voltage (VIN) under voltage lockout
2. Under voltage detection
3. Short-to-ground protection
4. Operation from either VIN or VREG for low battery voltage operation

Charge Pump (VCP, CP1, CP2)

A charge pump provides the voltage necessary to drive the high-side n-channel MOSFETs in the pre-regulator and the linear regulators.

Two external capacitors are required for charge pump operation. During the first half of the charge pump cycle, the flying capacitor between pins CP1 and CP2, is charged from either VIN or VREG, whichever is highest. During the second half of the

charge pump cycle the voltage on the flying capacitor charges the VCP capacitor. For most conditions the VCP minus VIN voltage is regulated to approximately 6.5 V.

The charge pump can provide enough current to operate the pre-regulator and the LDOs at full load provided VIN is greater than 6.0 V. Optional components D3, D4, and CP3 must be included if VIN drops below 6.0 V. Diode D3 should be a silicon diode rated for at least 200 mA/50 V with less than 50 μ A of leakage current when $V_R = 13$ V and $T_A = 125^\circ\text{C}$. Diode D4 should be a 1 A schottky diode with a very low forward voltage (V_F) rated to withstand at least 30 V.

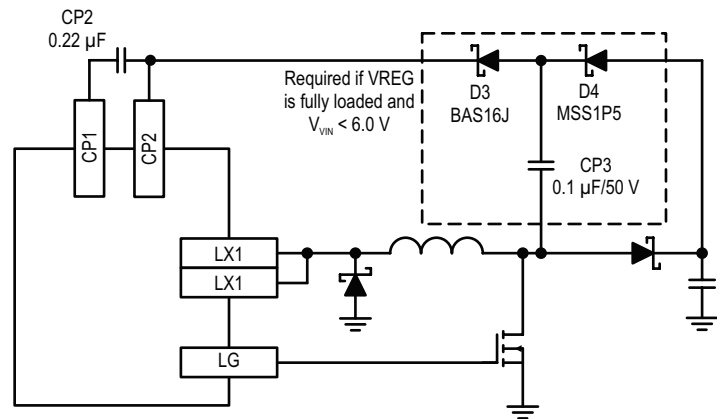

Figure 8: Charge Pump Circuit

The charge pump incorporates some protection features;

1. Under voltage lockout of PWM switching
2. Over voltage “latched” shutdown of the A4410

Startup and Shutdown Sequences

The startup and shutdown sequences of the A4410 are fixed. If no faults exist and ENBAT1 or ENBAT2 or ENB transition high the A4410 will perform its startup routine. If ENBAT1 and ENBAT2 and ENB are low for at least $EN_{td,FILT} + td_{LDO,OFF}$ (typically 65 μ s) the A4410 will enter a shutdown sequence. The startup and shutdown sequences are summarized in Table 2 and shown in a timing diagram in Figure 9.

Fault Reporting (NPOR, POK5V)

The A4410 includes two open-drain outputs for error reporting. The NPOR pin monitors the 1V25 and 3V3 outputs for under and over voltage. The POK5V pin monitors the V5 and V5P pin for under and over voltage.

The NPOR pin incorporates a 15 ms delay after both the 1V25

and 3V3 outputs have risen above their under voltage thresholds. This relatively long delay allows the micro-controller plenty of time to power-up and complete its initialization. There is virtually no NPOR delay if either the 1V25 or 3V3 falls below the under voltage threshold. The NPOR pin incorporates an 8 ms delay if either of the 1V25 or 3V3 outputs exceeds its over voltage threshold.

There are no significant delays on the POK5V output after V5 and V5P have risen above or fallen below their under voltage thresholds. Similar to the NPOR pin, the POK5V pin incorporates an 8 ms delay if either the V5 or V5P outputs exceed its over voltage threshold.

The V5P monitor is a bit unique. If V5P is accidentally connected to the battery voltage then POK5V will bypass the normal 8 ms over voltage delay and set itself low immediately.

The fault modes and their effects on NPOR and POK5V are covered in detail in Table 3.

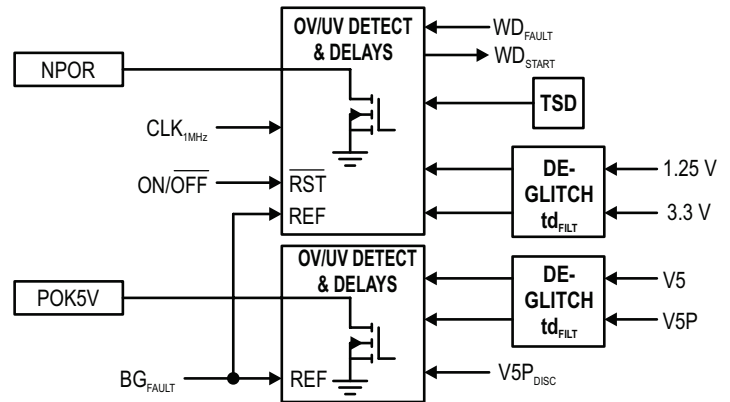

Figure 9: Fault Reporting Circuit

Table 2: Startup and Shutdown Logic (signal names consistent with Functional Block Diagram)

A4410 Status Signals					Regulator Control Bits (0=OFF, 1=ON)			A4410 MODE
EN	MPOR	VREG UV	1V25 UV	3xLDO UV	VREG ON	1V25 ON	LDOs ON	
X	1	X	X	X	0	0	0	RESET
0	0	1	1	1	0	0	0	OFF
1	0	1	1	1	1	0	0	STARTUP
1	0	0	1	1	1	1	0	↓
1	0	0	0	1	1	1	1	↓
1	0	0	0	0	1	1	1	RUN
0	0	0	0	0	1	1	1	DEGLITCH + DELAY
0	0	0	0	0	1	1	0	SHUTTING DOWN
0	0	0	0	1	1	0	0	↓
0	0	0	1	1	0	0	0	↓
0	0	1	1	1	0	0	0	OFF

X = DON'T CARE

EN = ENBAT1 + ENBAT2 + ENB

3xLDO UV = 3V3 + V5_UV + V5P_UV

MPOR = VCC_UV + VCP_UP + BG1_UV + BG2_UV + SLEW_UV/OV (latched) + FSET_UV/OV + TSD + VCP_OV (latched) + D1_MISSING (latched) + I_LIM,LX1 (latched)

TIME

Table 3: Summary of Fault Mode Operation

FAULT TYPE and CONDITION	A4410 RESPONSE TO FAULT	NPOR	POK5V	LATCHED FAULT?	RESET METHOD
V5P short to VBAT	POK5V goes low when V5P disconnect occurs, if the fault persists longer than t_{dOV} then set NPOR low and turn off all regulators	Low if fault lasts more than t_{dOV}	Low when V5P disconnect occurs	NO	Check for short circuits on V5P
V5, V5P over voltage	If OV condition persists for more than t_{dOV} then set POK5V low	Not effected	Low	NO	Check for short circuits on V5 or V5P
3V3 or 1V25 over voltage	If OV condition persists for more than t_{dOV} then set NPOR low and shut off all regulators	Low	Low if fault lasts more than t_{dOV}	YES	Check for short circuits then cycle EN or VIN
V5 or V5P under voltage	Closed loop control will try to raise the voltage but may be constrained by the foldback current limit	Not effected	Low	NO	Decrease the load
3V3 or 1V25 under voltage	Closed loop control will try to raise the voltage but may be constrained by the foldback or pulse-by-pulse current limit	Low	Not effected	NO	Decrease the load
V5 or V5P over current	Foldback current limit will reduce the output voltage	Not effected	Low if V5 or V5P are too low	NO	Decrease the load
3V3 over current	Foldback current limit will reduce the output voltage	Low if 3V3 < $V_{3V3,UV,L}$	Not effected	NO	Decrease the load
FB _{1V25} shorted to ground $V_{SS2} < V_{HIC2,EN}$, $V_{1V25} < 470$ mV	Continue to PWM but turn off LX2 when the high side MOSFET current exceeds I_{LIM2}	Low	Not effected	NO	Remove the short circuit
1V25 over current $V_{SS2} > V_{HIC2,EN}$ & $V_{1V25} < 470$ mV	Enters hiccup mode after 30 OCP faults	Low	Not effected	NO	Decrease the load
1V25 over current $V_{SS2} > V_{HIC2,EN}$ & $V_{1V25} > 470$ mV	Enters hiccup mode after 120 OCP faults	Low if 1V25 < $V_{1V25,UV,L}$	Not effected	NO	Decrease the load
VREG pin open circuit	VREG will decay to 0 V, LX1 will switch at maximum duty cycle so the voltage on the output capacitors will be very close to VBAT	Low if 3V3 or 1V25 are too low	Low if V5 or V5P are too low	NO	Connect the VREG pin
VREG over current $V_{VREG} < 1.95$ V & $V_{COMP1} = EA1_{VO(MAX)}$	Enters hiccup mode after 30 OCP faults	Low	Low	NO	Decrease the load
VREG over current $V_{VREG} > 1.95$ V & $V_{COMP1} = EA1_{VO(MAX)}$	Enters hiccup mode after 120 OCP faults	Low if 3V3 or 1V25 are too low	Low if V5 or V5P are too low	NO	Decrease the load
VREG over voltage $V_{REG,OV,H1} < V_{VREG}$	Stop PWM switching of LX1	Low if 3V3 or 1V25 are too low	Low if V5 or V5P are too low	NO	None
VREG asynchronous diode (D1) missing	Results in an MPOR after 1 detection, so all regulators are shut off	Low if 3V3 or 1V25 are too low	Low if V5 or V5P are too low	YES	Place D1 then cycle EN or VIN
Asynchronous diode (D1) short circuited or LX1 shorted to ground	Results in an MPOR after the high side MOSFET current exceeds $I_{LIM,LX1}$ so all regulators are shut off	Low if 3V3 or 1V25 are too low	Low if V5 or V5P are too low	YES	Remove the short then cycle EN or VIN

Table 3: Summary of Fault Mode Operation (continued)

FAULT TYPE and CONDITION	A4410 RESPONSE TO FAULT	NPOR	POK5V	LATCHED FAULT?	RESET METHOD
Slew pin open circuit (SLEW_UC)	Results in an MPOR, so all regulators are shut off	Low	Low	YES	Connect SLEW pin then cycle EN or VIN
Slew pin shorted to ground (SLEW_OC)	Results in an MPOR, so all regulators are shut off	Low	Low	YES	Remove the short then cycle EN or VIN
FSET/SYNC pin shorted to ground or open circuit	The A4410 operates at a default oscillator frequency of 450 kHz. If the fault occurs before power up: 1V25 and 3 LDOs are OFF. VREG (unloaded) runs in pulse skipping mode.	Low	Low	NO	Remove the short circuit or connect the pin
	The A4410 operates at a default oscillator frequency of 450 kHz. If the fault occurs after power up: 1V25 is OFF and 3 LDOs are ON.	Low	High		
Charge pump (VCP) over voltage	Results in an MPOR, so all regulators are shut off	Low	Low	YES	Check VCP/CP1/CP2 pins & components, then cycle EN or VIN
Charge pump (VCP) under voltage	Results in an MPOR, so all regulators are shut off	Low	Low	NO	Check VCP/CP1/CP2 pins and components
VCP pin open circuit	Results in VCP_UV and an MPOR, so all regulators are shut off	Low	Low	NO	Connect the VCP pin
VCP pin shorted to ground	Results on high current from the charge pump and (intentional) fusing of an internal trace. Also results in MPOR so all regulators are shut off.	Low	Low	NO	Remove the short circuit and replace the A4410
CP1 or CP2 pin open circuit	Results in VCP_UV and an MPOR, so all regulators are shut off	Low	Low	NO	Connect the CP1 or CP2 pins
CP1 pin shorted to ground	Results in VCP_UV and an MPOR, so all regulators are shut off	Low	Low	NO	Remove the short circuit
CP2 pin shorted to ground	Results on high current from the charge pump and (intentional) fusing of an internal trace. Also results in MPOR so all regulators are shut off.	Low	Low	NO	Remove the short circuit and replace the A4410
BG _{VREF} or BG _{FAULT} under voltage	Results in an MPOR, so all regulators are shut off	Low	Low	NO	Raise VIN or wait for BGs to power up
BG _{VREF} or BG _{FAULT} over voltage	If BG _{VREF} is too high, all regulators will appear to be OV (because BG _{FAULT} is good). If BG _{FAULT} is too high, all regulators will appear to be UV (because BG _{VREF} is good)	Low	Low	NO	Replace the A4410
VCC under voltage or shorted to ground	Results in an MPOR, so all regulators are shut off	Low	Low	NO	Raise VIN or remove short from VCC pin
WD _{ADJ} pin shorted to ground or open circuit	A WD _{ADJ} fault only effects the NPOR output. The remainder of the A4410 operates normally.	Low	High	NO	Remove the short circuit or connect the pin
Thermal shutdown	Results in an MPOR, so all regulators are shut off	Low	Low	NO	Let the A4410 cool

TIMING DIAGRAMS (Not to Scale)

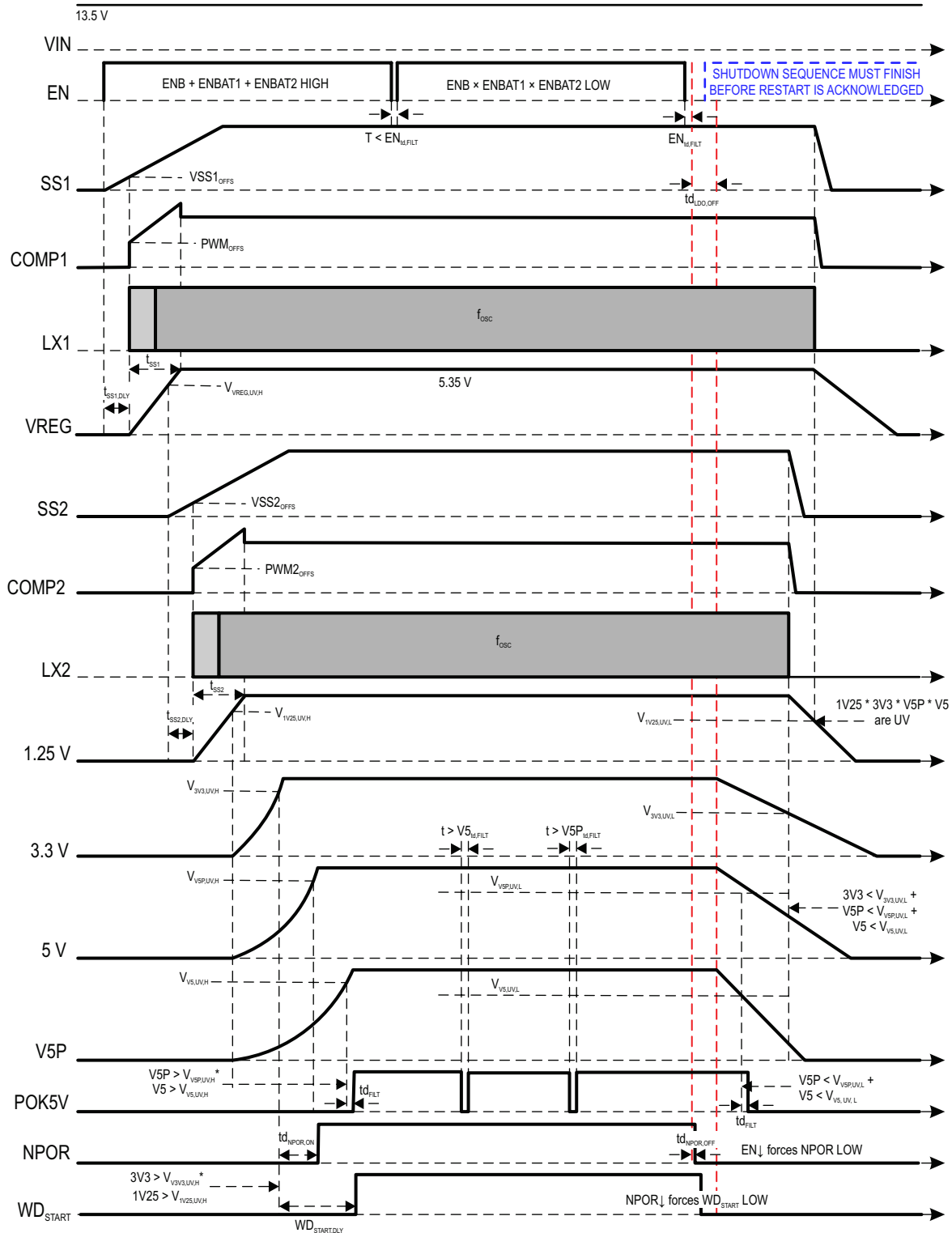

Figure 9: Startup and Shutdown by Enable

* is for "and", + is for "or"

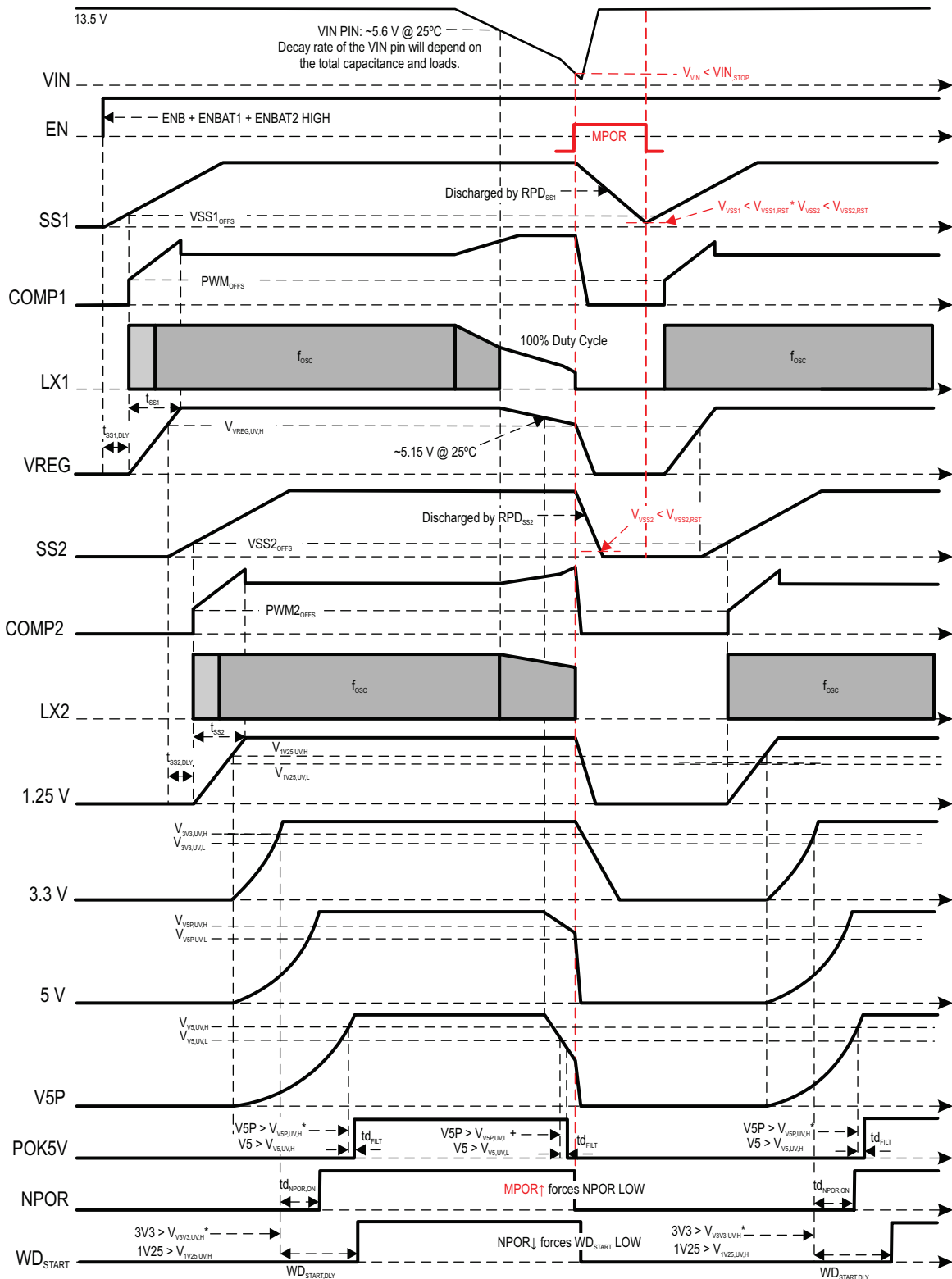

Figure 10: Input Voltage (VIN) Under Voltage for Buck Mode

* is for "and", + is for "or"

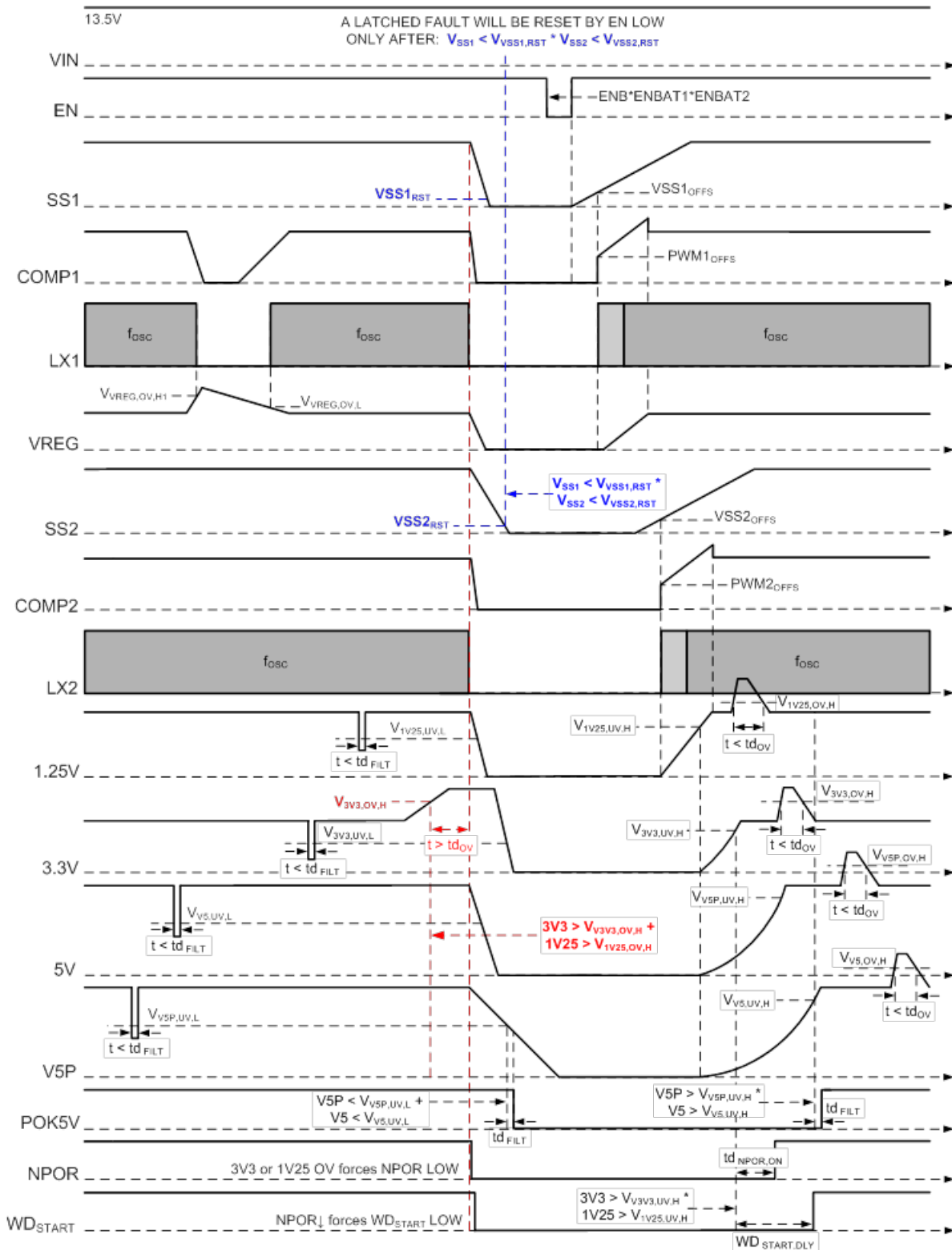

Figure 11: Over Voltage Operation for 1V25 and 3V3

* is for "and", + is for "or"

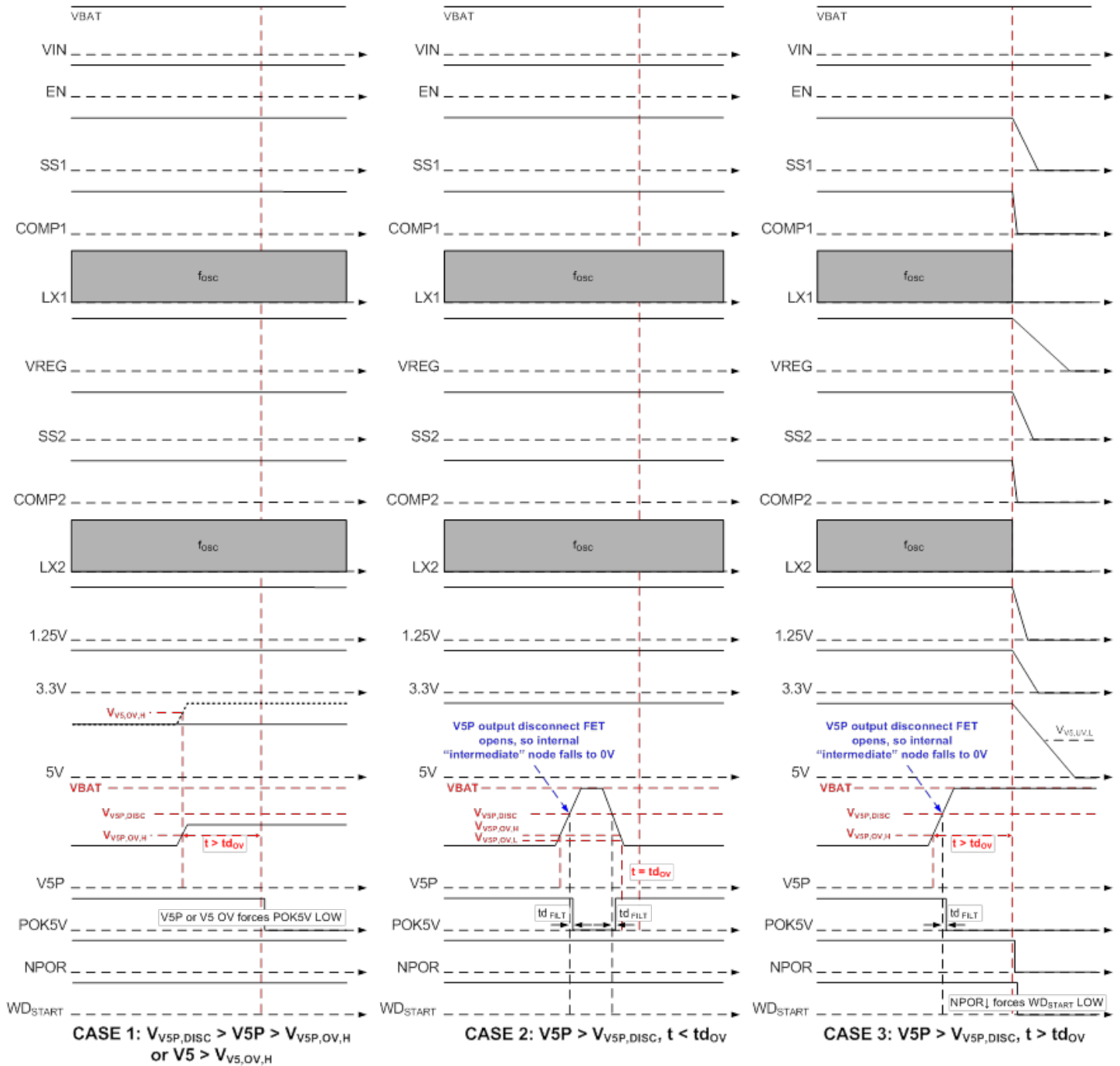

Figure 12: Over Voltage Operation for V5P and V5

* is for "and", + is for "or"

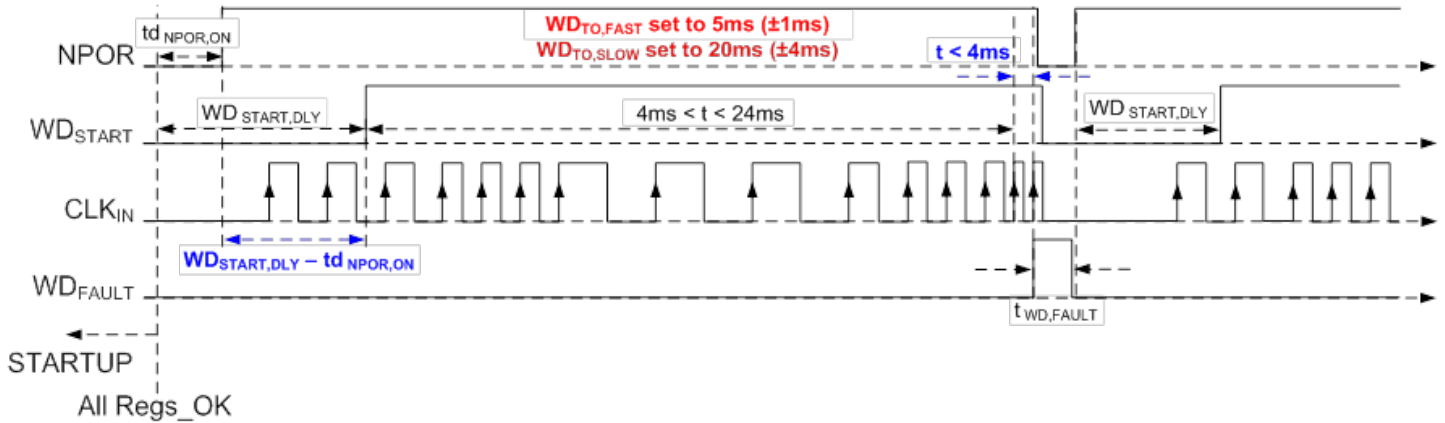

Figure 13a: Window Watchdog Timer FAST Clock Detection

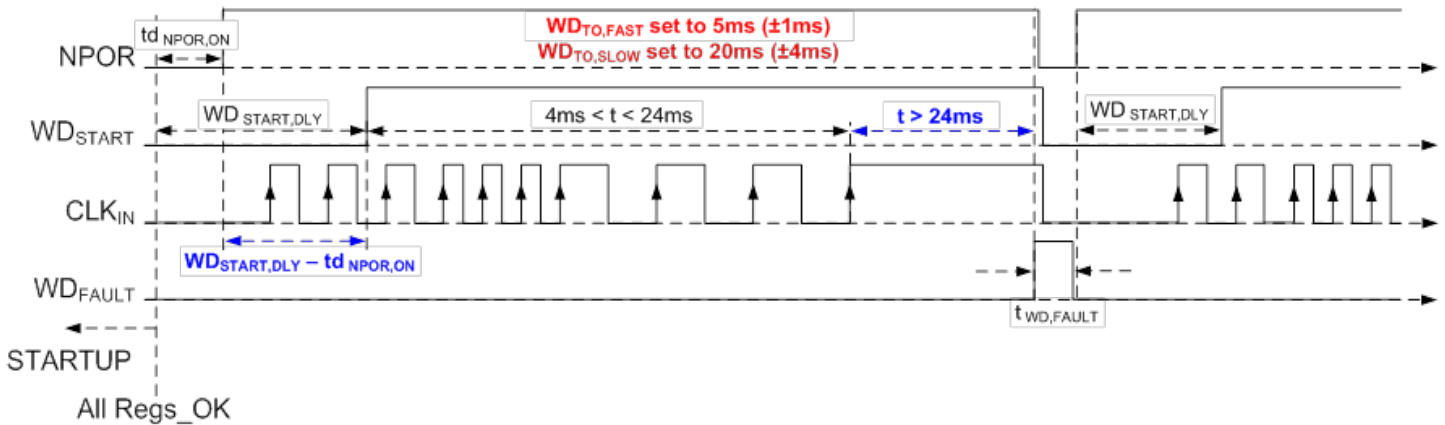

Figure 13b: Window Watchdog Timer SLOW Clock Detection

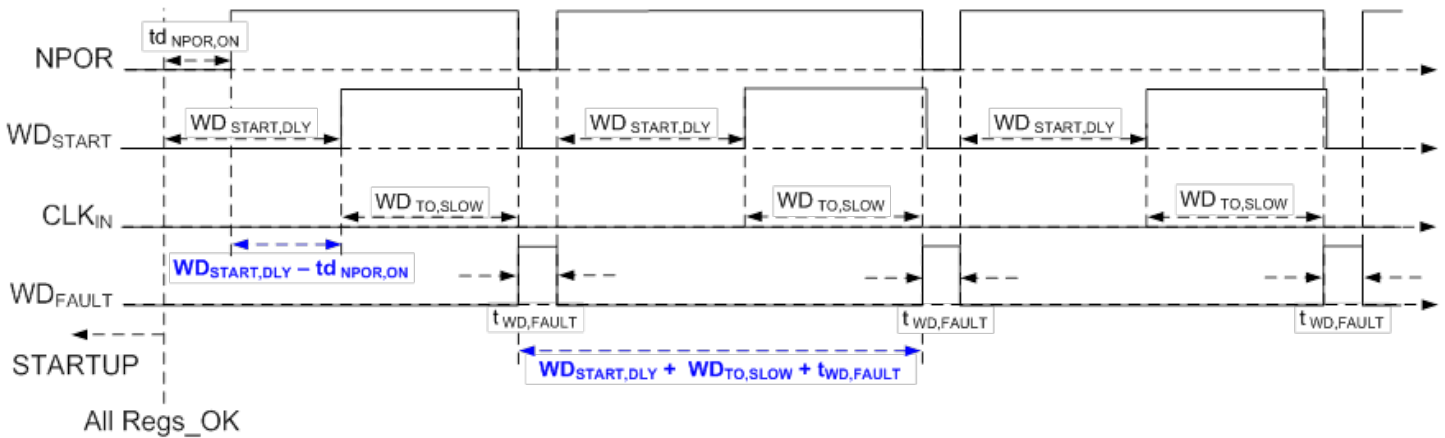

Figure 13c: Watchdog Timer Operation with CLK_{IN} Stuck LOW or HIGH at Startup

DESIGN AND COMPONENT SELECTION

PWM Switching Frequency (RFSET)

When the PWM switching frequency is chosen the designer should be aware of the minimum controllable on time, $t_{ON(MIN)}$ of the A4410. If the system's required on time is less than the A4410's minimum controllable on time then switch node jitter will occur and the output voltage will have increased ripple or oscillations.

The PWM switching frequency should be calculated using equation 1, where $t_{ON(MIN)}$ is the minimum controllable ON time of the A4410 (195 ns_{TYP}), and $V_{IN,MAX}$ is the maximum required operational input voltage (not the peak surge voltage).

$$f_{OSC} < \frac{5.35 V}{t_{ON,MIN} \times V_{IN,TYP}} \quad (1)$$

If the A4410's synchronization function is used then the base oscillator frequency should be chosen such that jitter will not result at the maximum synchronized switching frequency according to equation 1.

Output Inductors (L1 and L2)

For peak current mode control it is well known that the system will become unstable when the duty cycle is above 50% without adequate Slope Compensation (S_E). However, the slope compensation in the A4410 is a fixed value based on the oscillator frequency (f_{OSC}). Therefore, it is important to calculate an inductor value so the falling slope of the inductor current (S_F) will work well with the A4410's slope compensation.

Equations 2 and 3 can be used to calculate a range of values for the output inductor for the buck-boost and synchronous buck regulators. In equation 2a and 3a, slope compensation is a function of the switching frequency (f_{OSC}) according to equations 2b and 3b, and V_F is the asynchronous diodes forward voltage.

S_E is in A/ μ s, f_{OSC} is in kHz, and L will be in μ H

$$\frac{5.35 V + V_F}{S_{E1}} \leq L1 \leq \frac{2 \times (5.35 V + V_F)}{S_{E1}} \quad (2a)$$

$$S_{E1} = 0.0007 \times f_{OSC} + 0.0425 \quad (2b)$$

$$\frac{1.25 V}{2 \times S_{E2}} \leq L2 \leq \frac{1.25 V}{S_{E2}} \quad (3a)$$

$$S_{E2} = 0.0003 \times f_{OSC} + 0.0175 \quad (3b)$$

If equations 2a or 3a yield an inductor value that is not a standard value then the next closest available value should be used. The final inductor value should allow for 10% – 20% of initial toler-

ance and 20% – 30% of inductor saturation.

The inductors should not saturate given the peak operating current according to equations 4a and 4b. In equation 4a $V_{IN,MAX}$ is the maximum continuous input voltage, such as 16 V, and V_F is the asynchronous diodes forward voltage.

$$I_{PEAK1} = 4.6 A - \frac{S_{E1} \times (5.35 V + V_F)}{0.9 \times f_{OSC} \times (V_{IN,MAX} + V_F)} \quad (4a)$$

$$I_{PEAK2} = 2.4 A - \frac{S_{E2} \times 1.25 V}{0.9 \times f_{OSC} \times 5.45 V} \quad (4b)$$

After an inductor is chosen it should be tested during output short circuit conditions. The inductor current should be monitored using a current probe. A good design should be sure the inductor or the regulator are not damaged when the output is shorted to ground at maximum input voltage and the highest expected ambient temperature.

Output Capacitors

The output capacitors filter the output voltage to provide an acceptable level of ripple voltage and they store energy to help maintain voltage regulation during a load transient. The voltage rating of the output capacitors must support the output voltage with sufficient design margin.

The output voltage ripple (ΔV_{OUT}) is a function of the output capacitors parameters: C_O , ESR_{CO} , ESL_{CO} .

$$\Delta V_{OUT} = \Delta I_L \times ESR_{CO} + \frac{V_{IN} - V_{OUT}}{L_O} \times ESL_{CO} + \frac{\Delta I_L}{8f_{OSC}C_{OUT}} \quad (5)$$

The type of output capacitors will determine which terms of equation 8 are dominant. For ceramic output capacitors the ESR_{CO} and ESL_{CO} are virtually zero so the output voltage ripple will be dominated by the third term of equation 5.

$$\Delta V_{OUT} = \frac{\Delta I_L}{8f_{OSC}C_{OUT}} \quad (6)$$

To reduce the voltage ripple of a design using ceramic output capacitors simply increase the total capacitance, reduce the inductor current ripple (i.e. increase the inductor value), or increase the switching frequency.

The transient response of the regulator depends on the number and type of output capacitors. In general, minimizing the ESR of the output capacitance will result in a better transient response. The ESR can be minimized by simply adding more capacitors in parallel or by using higher quality capacitors. At the instant of a fast load transient (di/dt), the output voltage will change by the

amount

$$\Delta V_{OUT} = \Delta I_{LOAD} \times ESR_{CO} + \frac{di}{dt} ESL_{CO} \quad (7)$$

After the load transient occurs, the output voltage will deviate from its nominal value for a short time. This time will depend on the system bandwidth, the output inductor value, and output capacitance. Eventually, the error amplifier will bring the output voltage back to its nominal value.

The speed at which the error amplifier will bring the output voltage back to its setpoint will depend mainly on the closed-loop bandwidth of the system. A higher bandwidth usually results in a shorter time to return to the nominal voltage. However, a higher bandwidth system may be more difficult to obtain acceptable gain and phase margins. Selection of the compensation components (R_Z , C_Z , C_P) are discussed in more detail in the Compensation Components section of this data sheet.

Ceramic Input Capacitors

The ceramic input capacitor(s) must limit the voltage ripple at the VIN pin to a relatively low voltage during maximum load. Equation 8 can be used to calculate the minimum input capacitance,

$$C_{IN} \geq \frac{I_{OUT,MAX} \times 0.25}{0.90 \times f_{OSC} \times 50 \text{ mV}} \quad (8)$$

Where $I_{OUT,MAX}$ is the maximum current from the pre-regulator,

$$I_{OUT,MAX} = I_{3V3} + I_{VSP} + I_{V5} + 0.3 \times I_{1V25} + 20 \text{ mA} \quad (9)$$

A good design should consider the dc-bias effect on a ceramic capacitor – as the applied voltage approaches the rated value, the capacitance value decreases. The X5R and X7R type capacitors should be the primary choices due to their stability versus both DC bias and temperature. For all ceramic capacitors, the DC bias effect is even more pronounced on smaller case sizes so a good design will use the largest affordable case size (i.e. 1206/16 V or 1210/50 V).

Buck-Boost Asynchronous Diode (D1)

The highest peak current in the asynchronous diode (D1) occurs when VIN is very low (2.8 V) and both the buck and boost operate at their maximum duty cycles (approximately 84% and 67%, respectively),

$$\Delta I_{B/B} = \frac{1.88}{0.9 \times f_{OSC} \times LI} \quad (10)$$

$$I_{PK,B/B} = 1.5 \times \left(I_{OUT,MAX} + 0.16 \times \frac{\Delta I_{B/B}}{2} \right) \quad (11)$$

Where $I_{OUT,MAX}$ is the maximum current from the pre-regulator defined by equation 9.

The highest average current in the asynchronous diode occurs when VIN is at its maximum, $D_{BOOST} = 0\%$, and $D_{BUCK} = \text{minimum}$ (16% at 2 MHz),

$$I_{AVG} = I_{OUT,MAX} \times (1 - D_{BUCK,MIN}) = I_{OUT,MAX} \times 0.84 \quad (12)$$

Where $I_{OUT,MAX}$ is calculated using equation 9.

Boost MOSFET (Q1)

The RMS current in the boost MOSFET (Q1) occurs when VIN is very low (2.8 V) and both the buck and boost operate at their maximum duty cycles (approximately 84% and 67%, respectively),

$$I_{Q1,RMS} = \sqrt{0.67 \times \left[\left(I_{PK,B/B} - \frac{\Delta I_{B/B}}{2} \right)^2 + \frac{\Delta I_{B/B}}{12} \right]} \quad (13)$$

Where $\Delta I_{B/B}$ and $I_{PK,B/B}$ are derived using equations 10 and 11, respectively.

The boost MOSFET should have a total gate charge of less than 14 nC at a V_{GS} of 5 V. The V_{DS} rating of the boost MOSFET should be at least 20 V. Several recommendations are shown in the Functional Block Diagram/Typical Schematic.

Boost Diode (D2)

In buck mode this diode will simply conduct the output current. However, in buck boost mode the currents in this diode may increase quite a bit.

$$I_{PK,B/B} = 1.5 \times \left(I_{OUT,MAX} + 0.16 \times \frac{\Delta I_{B/B}}{2} \right) \quad (14)$$

$$I_{AVG} = 0.33 \times I_{PK,B/B} - 0.16 \times \frac{\Delta I_{B/B}}{2} \quad (15)$$

Where $\Delta I_{B/B}$ is derived using equation 10.

Charge Pump Capacitors

The charge pump requires two capacitors: a 1 μF connected from pin VCP to VIN and 0.22 μF connected between pins CP1 and CP2. These capacitors should be a high-quality ceramic capacitor, such as an X5R or X7R, with a voltage rating of at least 16 V.

Soft Start and Hiccup Mode Timing (C_{SS1} , C_{SS2})

The soft start times of the buck converters are determined by the value of the capacitance at the soft start pin, C_{SSn} ($n = 1$ or 2 for the pre-regulator or synchronous buck, respectively).

The voltage at the soft start pin will start from 0 V and will be charged by the soft start current, $I_{SSn_{SU}}$ ($n = 1$ or 2). However, PWM switching will not begin instantly because the voltage at the soft start pin must rise above the soft start offset voltage ($V_{SSn_{OFFS}}$). The soft start delay ($t_{SSn_{DELAY}}$) can be calculated using equation 16,

$$t_{SSn_{DELAY}} = C_{SSn} \times \left(\frac{V_{SSn_{OFFS}}}{I_{SSn_{SU}}} \right) \quad (16)$$

If the A4410 is starting into a very heavy load a very fast soft start time may cause the regulator to exceed the pulse-by-pulse over current threshold. This occurs because the total of the full load current, the inductor ripple current, and the additional current required to charge the output capacitors ($I_{CO} = C_O \times V_{OUT} / t_{SS}$) is higher than the pulse-by-pulse current threshold, as shown in Figure 14.

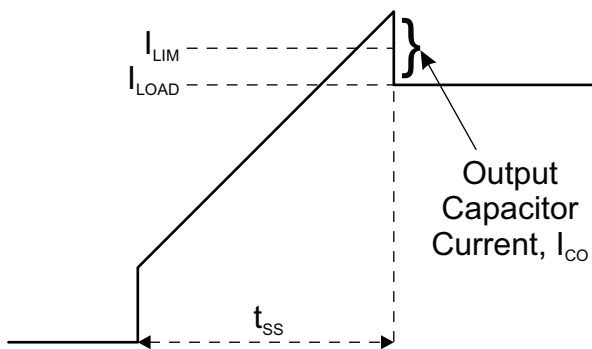

Figure 14: Output Current (I_{CO}) During Startup

To avoid prematurely triggering hiccup mode the soft start capacitor, C_{SSn} , should be calculated according to equation 17,

$$C_{SSn} \geq \frac{I_{SSn_{SU}} \times V_{OUT} \times C_{OUT}}{0.8\text{ V} \times I_{CO}} \quad (17)$$

Where V_{OUT} is the output voltage, C_{OUT} is the output capacitance, I_{CO} is the amount of current allowed to charge the output capacitance during soft start (recommend $0.1\text{ A} < I_{CO} < 0.3\text{ A}$). Higher values of I_{CO} result in faster soft start time and lower values of I_{CO} insure that hiccup mode is not falsely triggered. We recommend starting the design with an I_{CO} of 0.1 A and increasing it only if the soft start time is too slow. If a non-standard

capacitor value for C_{SSn} is calculated, the next larger value should be used.

The output voltage ramp time, t_{SSn} , can be calculated by using equation 18,

$$t_{SSn} = V_{OUT} \times \frac{C_{OUT}}{I_{CO}} \quad (18)$$

When the A4410 is in hiccup mode, the soft start capacitor sets the hiccup period. During a startup attempt, the soft start pin charges the soft start capacitor with $I_{SSn_{SU}}$ and discharges the same capacitor with $I_{SSn_{HIC}}$ between startup attempts.

Compensation Components (RZ, CZ, CP)

To compensate the system it's important to understand where the buck power stage, load resistance, and output capacitance form their poles and zeros in frequency. Also, its important to understand that the (Type II) compensated error amplifier introduces a zero and two more poles and where these should be placed to maximize the system's stability, provide a high bandwidth, and optimize the transient response.

First, we will take a look at the power stage of the A4410, the output capacitors, and the load resistance. This circuitry is commonly referred as the "control to output" transfer function. The low frequency gain of this section depends on the COMP to SW current gain (gm_{POWER}), and the value of the load resistor (RL). The DC gain (GCO_{0HZ}) of the control-to-output is

$$GCO_{0Hz} = gm_{POWER} \times RL \quad (19)$$

The control to output transfer function has a pole (f_{P1}) formed by the output capacitance (C_{OUT}) and load resistance (RL) at

$$f_{P1} = \frac{1}{2\pi \times RL \times C_{OUT}} \quad (20)$$

The control to output transfer function also has a zero (f_{Z1}) formed by the output capacitance (C_{OUT}) and its associated ESR

$$f_{Z1} = \frac{1}{2\pi \times ESR \times C_{OUT}} \quad (21)$$

For a design with very low-ESR type output capacitors (i.e. ceramic or OSCON output capacitors), the ESR zero, f_{Z1} , is usually at a very high frequency so it can be ignored. On the other hand, if the ESR zero falls below or near the 0 dB crossover frequency of the system (as is the case with electrolytic output capacitors), then it should be cancelled by the pole formed by the CP capacitor and the RZ resistor (discussed and identified later as f_{P3}).

A bode plot of the control-to-output transfer function for the A4410 application circuit shown on page 2 ($V_{OUT} = 5.0\text{ V}$, $I_{OUT} = 2.5\text{ A}$, $R_L = 2\ \Omega$) is shown in Figure 15. The pole at f_{p1} can easily be seen at 1.9 kHz while the ESR zero, f_{z1} , occurs at a very high frequency, 636 kHz (this is typical for a design using ceramic output capacitors). Note, there is more than 90° of total phase shift because of the double-pole at half the switching frequency.

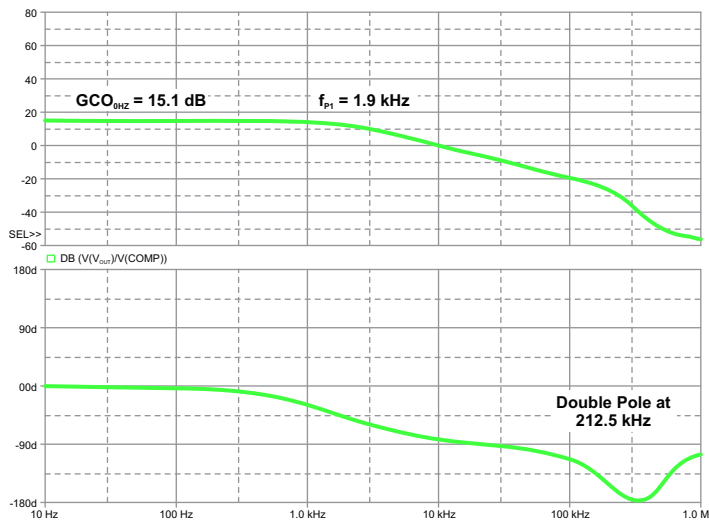

Figure 15: Control-to-Output Bode Plot

Next, we will take a look at the feedback resistor divider, (R_{FB1} and R_{FB2}), the error amplifier (gm), and its compensation network $R_Z/C_Z/C_P$. It greatly simplifies the transfer function derivation if $R_O \gg R_Z$, and $C_Z \gg C_P$. In most cases, $R_O > 2\text{ M}\Omega$, $1\text{ k}\Omega < R_Z < 100\text{ k}\Omega$, $220\text{ pF} < C_Z < 47\text{ nF}$, and $C_P < 50\text{ pF}$, so the following equations are very accurate.

The low frequency gain of the control section (GC_{0Hz}) is formed by the feedback resistor divider and the error amplifier. It can be calculated using equation 24, where V_{OUT} is the output voltage, V_{FB} is the reference voltage (0.8 V), gm is the error amplifier transconductance (750 $\mu\text{A/V}$), and R_O is the error amplifier output impedance ($AVOL/gm$).

$$\begin{aligned} GC_{0Hz} &= \frac{R_{FB2}}{R_{FB1} + R_{FB2}} \times gm \times R_O \\ &= \frac{V_{FB}}{V_{OUT}} \times gm \times R_O \\ &= \frac{V_{FB}}{V_{OUT}} \times AVOL \end{aligned} \quad (22)$$

The transfer function of the Type-II compensated error amp has a (very) low frequency pole (f_{p2}) dominated by the output error amplifier's output impedance R_O and the C_Z compensation capacitor,

$$f_{p2} = \frac{1}{2\pi \times R_O \times C_Z} \quad (23)$$

The transfer function of the Type-II error amp also has a low frequency zero (f_{z2}) dominated by the R_Z resistor and the C_Z capacitor.

$$f_{z2} = \frac{1}{2\pi \times R_Z \times C_Z} \quad (24)$$

Lastly, the transfer function of the Type-II compensated error amp has a (very) high frequency pole (f_{p3}) dominated by the R_Z resistor and the C_P capacitor

$$f_{p3} = \frac{1}{2\pi \times R_Z \times C_P} \quad (25)$$

A bode plot of the error amplifier and its compensation network is shown in Figure 16, f_{p2} , f_{p3} , and f_{z2} are indicated on the magnitude plot. Notice that the zero (f_{z2} at 3.8 kHz) has been placed so that it is just above the pole at f_{p1} previously shown in the control-to-output bode plot at 1.9 kHz, Figure 15. Placing f_{z2} just above f_{p1} will result in excellent phase margin, but relatively slow transient recovery time, as we will see later.

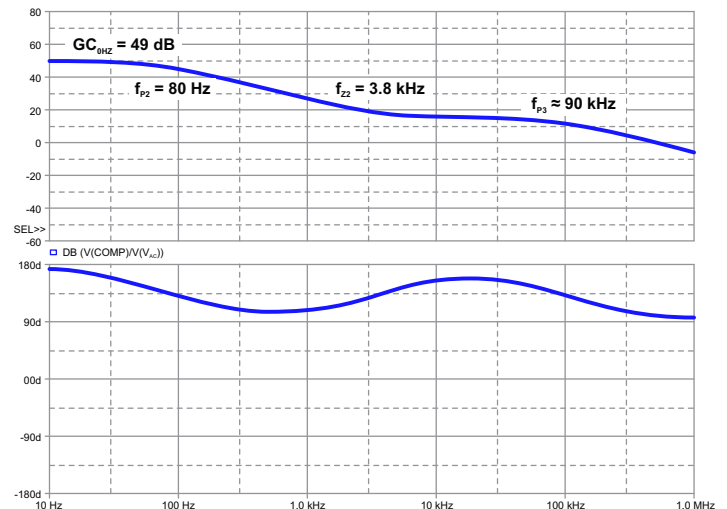

Figure 16: Type-II Compensated Error Amplifier

Finally, we take a look at the combined bode plot of both the control-to-output and the compensated error amp – see the red curve shown in Figure 17. Careful examination of this plot shows that the magnitude and phase of the entire system (in red) are simply the sum of the error amp response (blue) and the control to output response (green). As shown in Figure 17, the bandwidth of this system (f_c) is 60 kHz, the phase margin is 69 degrees, and the gain margin is 14 dB.

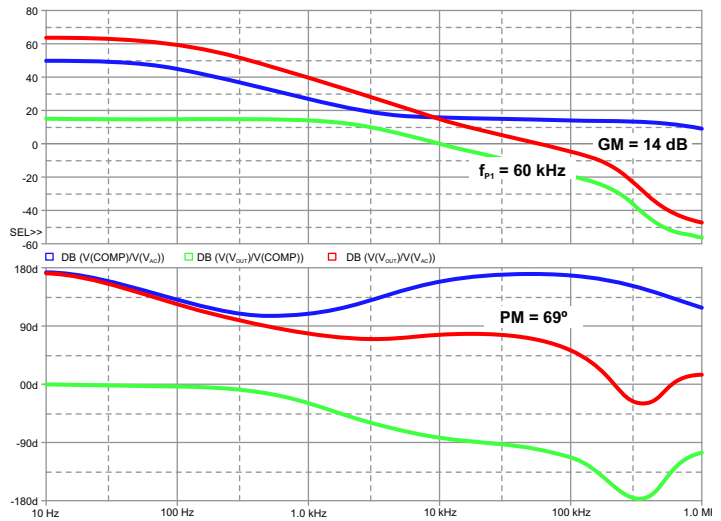

Figure 17: Bode Plot of the Complete System
(red curve)

PCB LAYOUT RECOMMENDATIONS

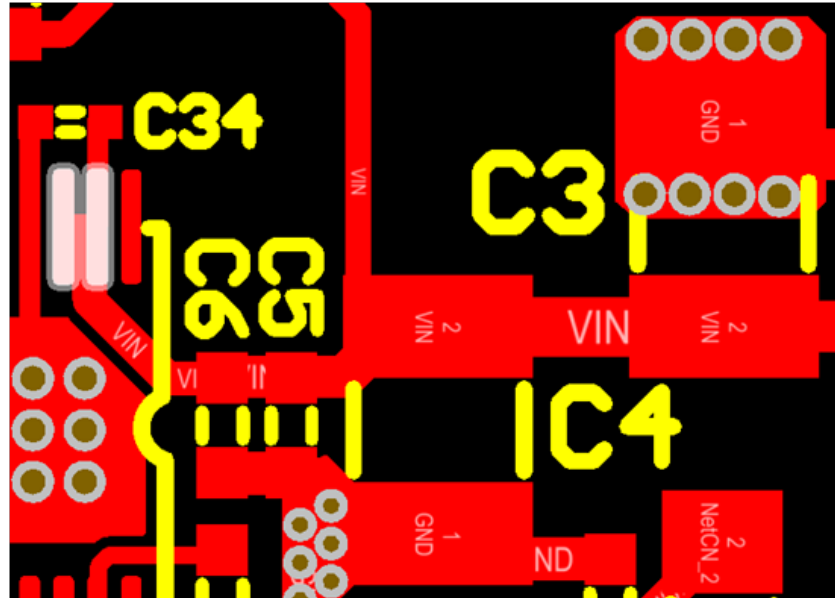

Figure 18: PCB Layout #1

The input ceramic capacitors (C3, C4, C5, C6, C34) must be located as close as possible to the VIN pins. In general, the smaller capacitors (0402, 0603) must be placed very close to the VIN pin. The larger capacitors (4.7 F, 50 V, 1210) should be placed within 0.5 inches of the VIN pin. There must not be any vias between the input capacitors and the VIN pins.

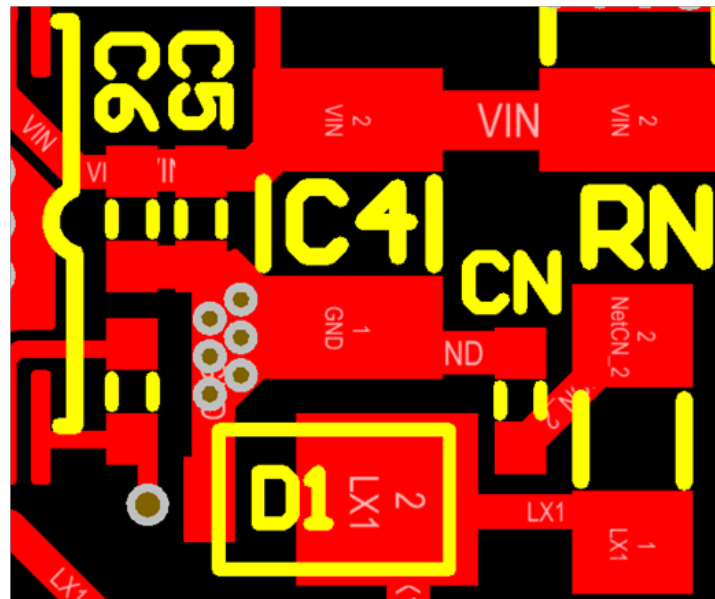

Figure 19: PCB Layout #2

The pre-buck asynchronous diode (D1), input ceramic capacitors (C4, C5, C6), and RC snubber (RN, CN) must be routed on one layer and “star” grounded at a single location with multiple vias.

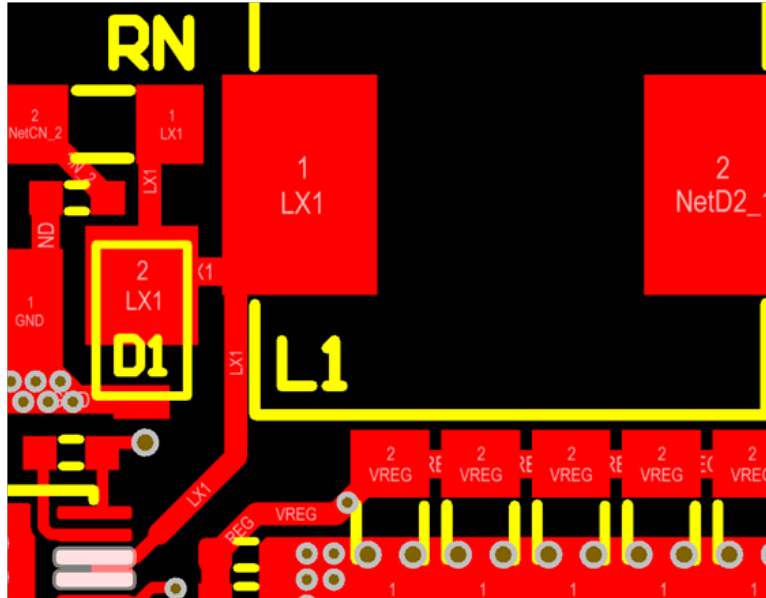

Figure 20: PCB Layout #3

The pre-buck output inductor (L1) should be located close to the LX1 pins.
 The LX1 trace widths (to L1, D1, RN) should be relatively wide and preferably on the same layer as the IC.

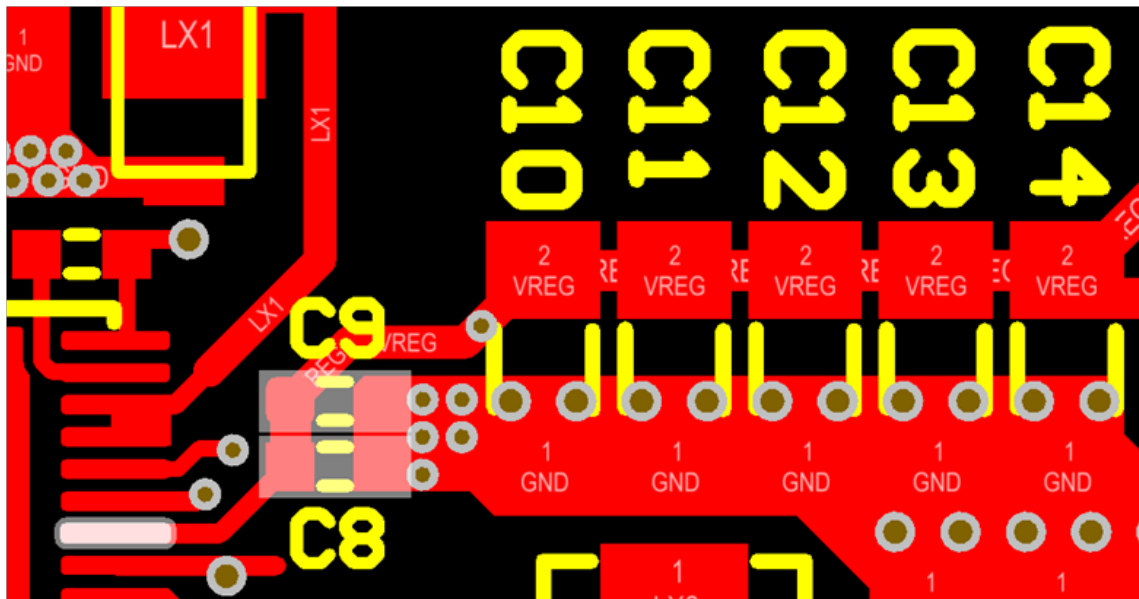

Figure 21: PCB Layout #4

The pre-buck regulators output ceramic capacitors (C10 – C14) should be located near the VREG pin.
 There must be 1 or 2 smaller ceramic capacitors (C8, C9) as close as possible to the VREG pin.

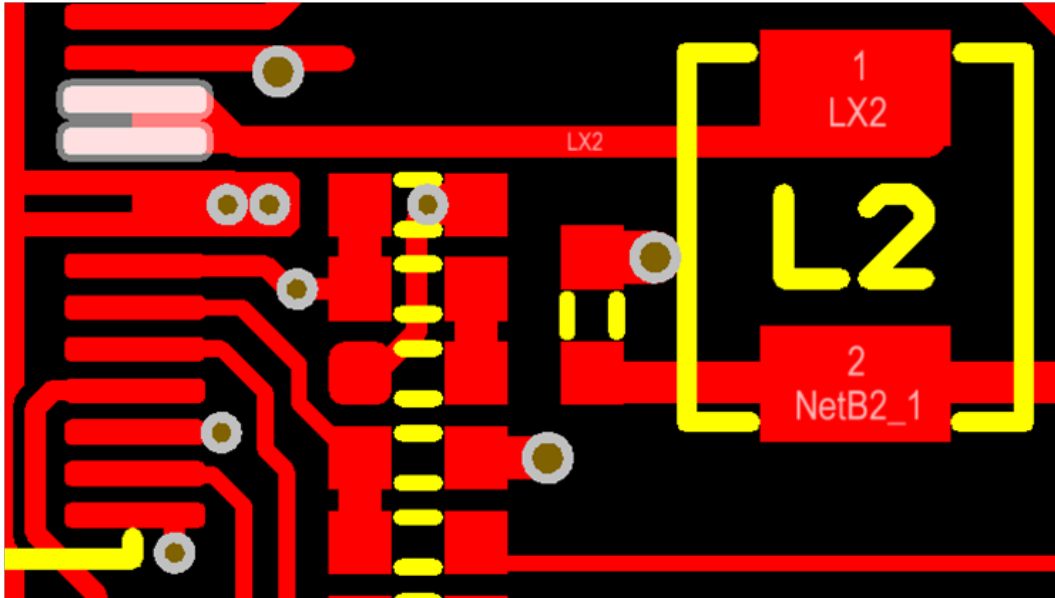

Figure 22: PCB Layout #5

The synchronous buck output inductor should be located near the LX2 pins. The trace from the LX2 pins to the output inductor (L2) should be relatively wide and preferably on the same layer as the IC.

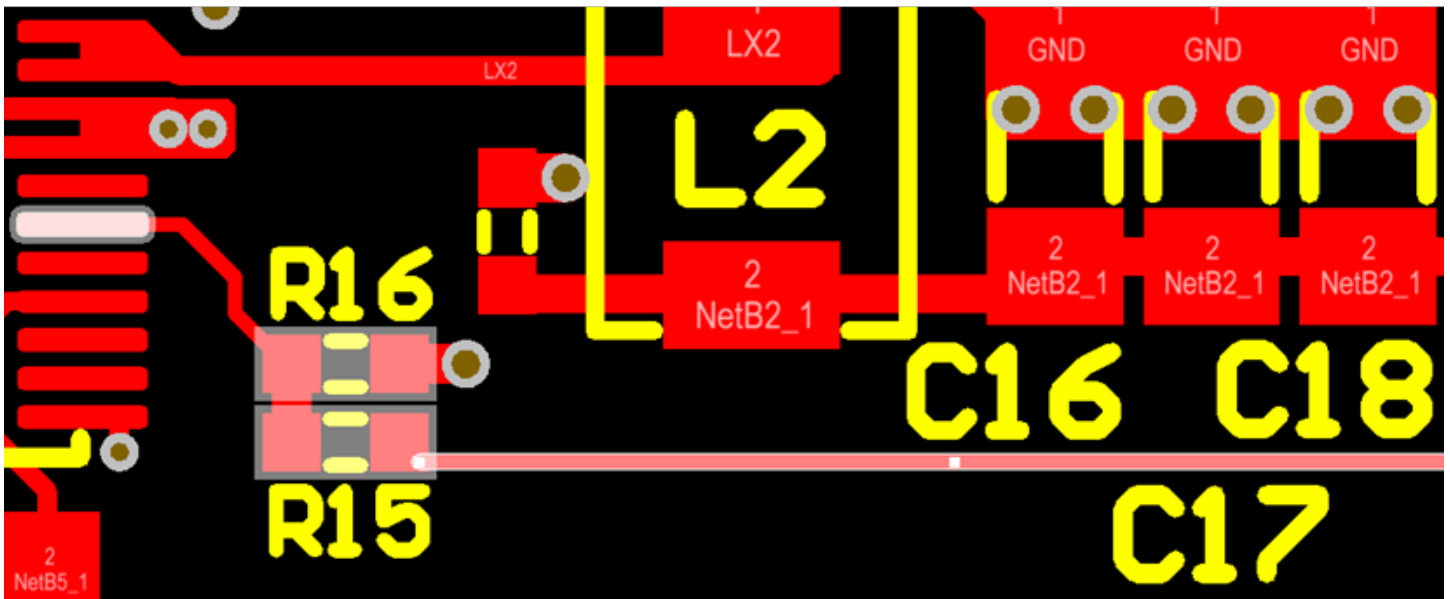

Figure 23: PCB Layout #6

If the synchronous buck is adjustable, the two feedback resistors (R15, R16) must be located near either the FBADJ or FB1V25 pin. The output capacitors (C16 – C18) should be located near the load. The output voltage sense trace (to R15) must connect at the load for the best regulation.

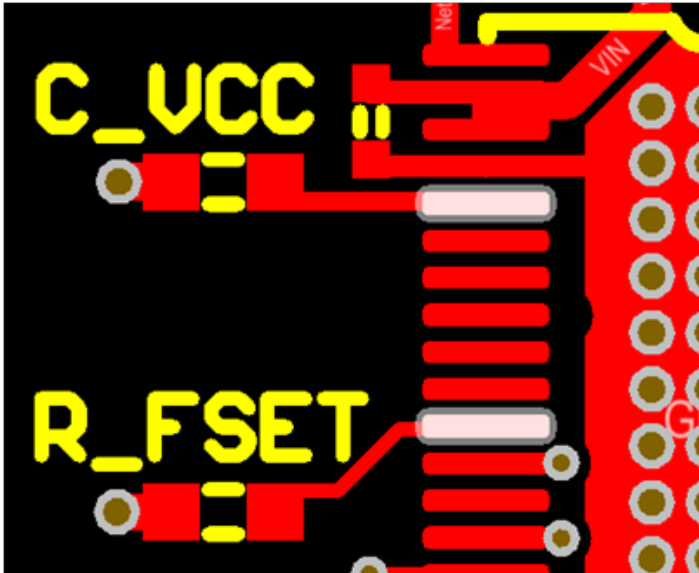

Figure 26: PCB Layout #9

The FSET resistor must be placed very close to the FSET/SYNC pin. Similarly, the VCC bypass capacitor must be placed very close to the VCC pin.

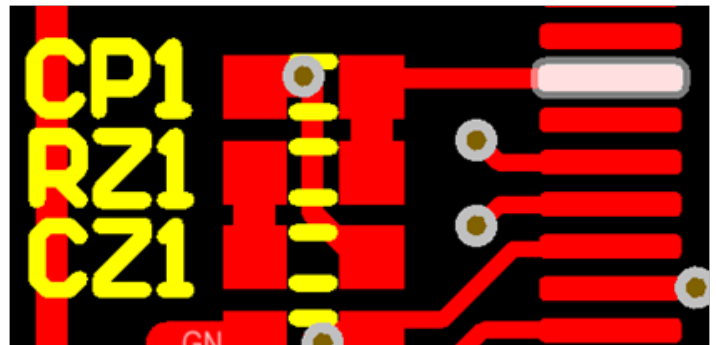

Figure 27: PCB Layout #10

The COMP network for both buck regulators (CZx, RZx, CPx) must be located very close to the COMPx pin.

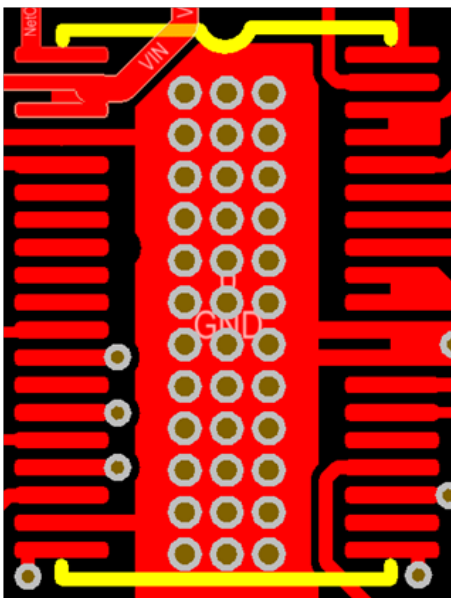

Figure 28: PCB Layout #11

The thermal pad under the A44xx must connect to the ground plane(s) with multiple vias.

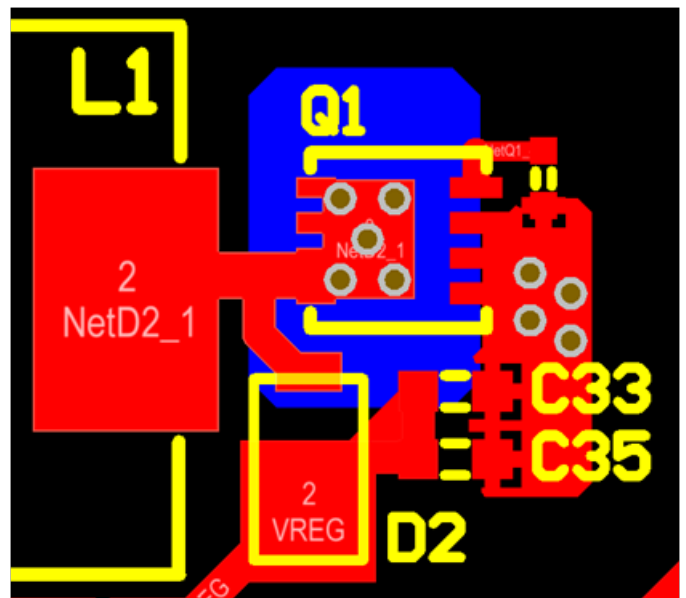

Figure 29: PCB Layout #12

The boost MOSFET (Q1) and the boost diode (D2) must be placed very close to each other. Q1 should have thermal vias to a polygon on the bottom layer. Also, there should be “local” bypass capacitors (C33, C35).

PACKAGE OUTLINE DRAWING

For Reference Only – Not for Tooling Use

(Reference JEDEC MO-153 BDT-1)

Dimensions in millimeters

NOT TO SCALE

Dimensions exclusive of mold flash, gate burrs, and dambar protrusions
Exact case and lead configuration at supplier discretion within limits shown

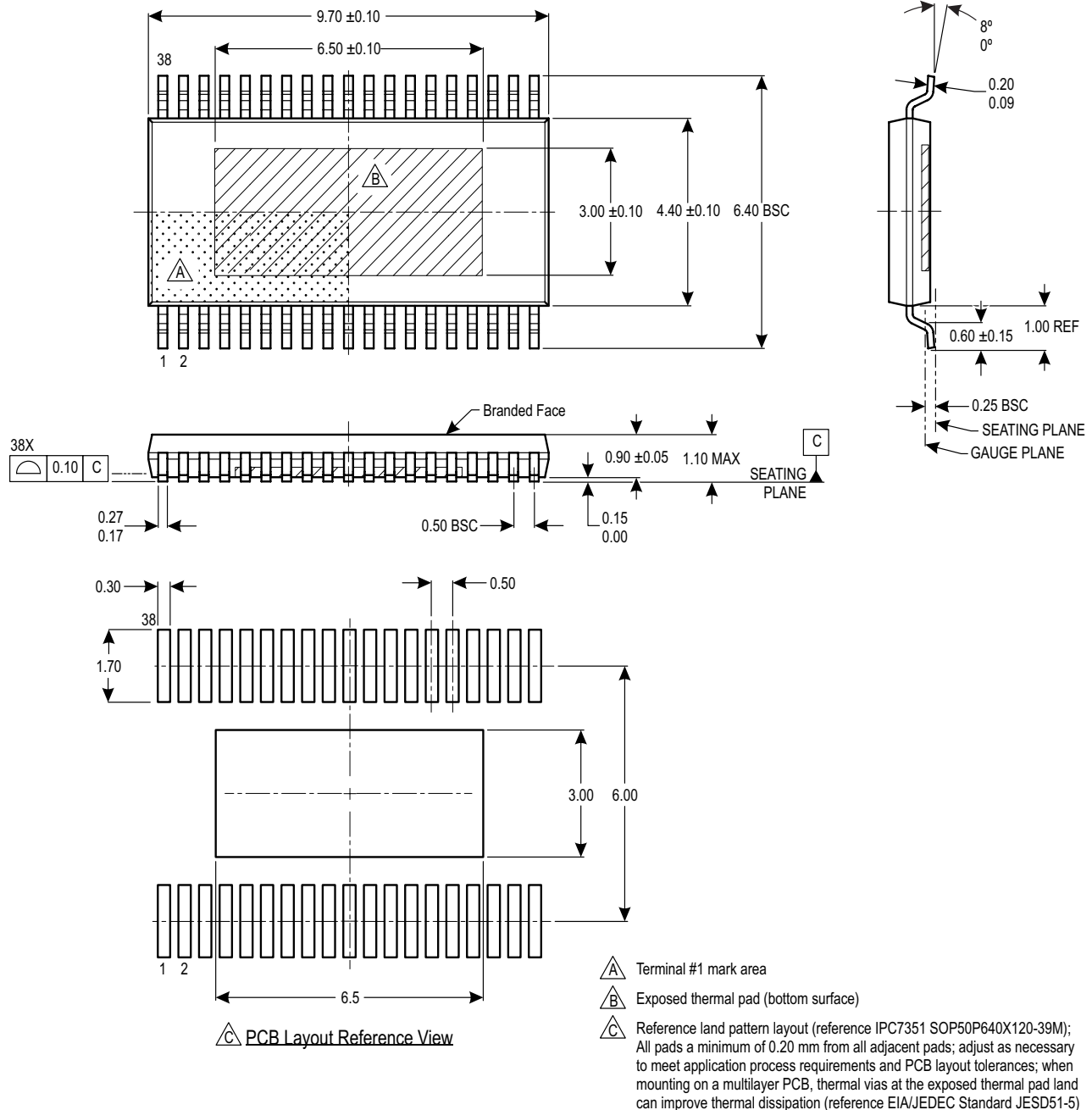

Figure 30: Package LV, 38-Pin eTSSOP

Revision History

Number	Date	Description
–	April 3, 2015	Initial Release
1	July 2, 2018	Product status changed to Last-Time Buy
2	February 1, 2019	Product status changed to Discontinued
3	February 7, 2020	Minor editorial updates

Copyright 2020, Allegro MicroSystems.

Allegro MicroSystems reserves the right to make, from time to time, such departures from the detail specifications as may be required to permit improvements in the performance, reliability, or manufacturability of its products. Before placing an order, the user is cautioned to verify that the information being relied upon is current.

Allegro's products are not to be used in any devices or systems, including but not limited to life support devices or systems, in which a failure of Allegro's product can reasonably be expected to cause bodily harm.

The information included herein is believed to be accurate and reliable. However, Allegro MicroSystems assumes no responsibility for its use; nor for any infringement of patents or other rights of third parties which may result from its use.

Copies of this document are considered uncontrolled documents.

For the latest version of this document, visit our website:

www.allegromicro.com