



The 5-Phase Stepping Driver

PMM-MA-50034-10

AC100V to 230V

Micro-step (500 x 1 to 250 divisions)



● Applicable motors



Characteristics

- **Conformity to UL Standards and CE Marking.**
This driver conforms to UL Standards and CE Marking.
- **Wide-range input power specifications**
Input source power can be used in wide range from AC 100 to 230 V.
- **Micro-step function available**
Smooth operation without vibration at low speeds can be realized.

Built-in function

- **Micro-step function**
Resolutions set by using the rotary switch enable the micro-step drive. However, this function and the automatic micro function cannot be used simultaneously.
- **Resolution setting function**
16 resolutions ranging from 1- to 250-division can be set for the basic step angle of stepping motor by using the rotary switch.
- **Pulse input system selection function**
Either "Pulse and direction mode" or "2-input mode" can be selected, using a dipswitch. Resolution setting function.
- **2 types of stepping motor**
The PM driver "PMM-MA-50034-10" lineup as the standard combination consists of two types the "STEPSYN H" series that conform to CE Marking and the standard "STEPSYN H" series. Combining with the "STEPSYN H" series that conform to CE Marking provides the conformity to the EMC Directive.

PM driver specifications

Item		PMM-MA-50034-10	
Standard specifications	Environment	Input source	Single phase AC100V~230V+10,-15% 50/60Hz
		Source current	4 A (at AC 100 V) 2 A (at AC 200 V)
		Protection class	Class I
		Operating environment	Installation category (overvoltage category): II, Pollution degree:2
		Operating ambient temperature	0~+50°C
		Conservation temperature	-20~+70°C
		Operating ambient humidity	35~85%RH (no condensation)
		Conservation humidity	10~90%RH (no condensation)
		Operating altitude	Maximum 1000 m above sea level
		Vibration resistance	Tested under the following conditions: Frequency range: 10 to 55 Hz, 0.5 G along the X, Y, and Z axes for 2 hours
		Impact resistance	No abnormality for the NDS-C-0110 Standard, Section 3.2.2, Division "C".
		Withstand voltage	No abnormality against an AC 1500 V application between the power input terminal and the cabinet for one minute.
		Insulation resistance	Minimum 10 MΩ when applying the DC 500 V Megger between the power input terminal and the cabinet.
Function	Mass(Weight)	1.0kg(2.20 lbs)	
	Protection function	Against PM driver overheat	
	Selection function	Automatic current reduction, excitation mode, pulse input system, step angle, and operation current	
I/O signals	LED indicator	Power supply monitor, phase origin monitor, pulse monitor, and alarm monitor.	
	Command pulse input signal	Photocoupler input system, input resistance 330 Ω Input signal voltage: "H" level: 4.0 to 5.5 V, "L" level: 0 to 0.5 V Maximum input frequency micro mode: 100 kpulses/s,	
	Power down input signal	Photocoupler input system, input resistance 330 Ω Input signal voltage: "H" level: 4.0 to 5.5 V, "L" level: 0 to 0.5 V	
	Phase origin monitor output signal	Open collector output by photocoupler Output signal standard Vceo: Maximum 30 V, Ic: Maximum 5 mA	
	Alarm output signal	Open collector output by photocoupler Output signal standard Vceo: Maximum 30 V, Ic: Maximum 5 mA	
	Ready output signal	Open collector output by photocoupler Output signal standard Vceo: Maximum 30 V, Ic: Maximum 5 mA	

UL Standard and CE Marking

Product	UL standard		CE Marking		
	Applied standard	File No.	Low Voltage Directive	EMC Directive	
				Emission	Immunity
PM driver	UL508C	E179775	EN50178	EN50081-2 (Class A)	EN50082-2 (Class A)

- The stepping motor CE Marking is applied for the "STEPSYN H" series that conforms to CE Marking.
- The conformity to the EMC Directive is checked under the installation environment shown in Figure 1. However, the conformity to the EMC Directive cannot be checked in the installation environment used for the user's equipment that varies depending on the user's control panel configuration in which PM drivers and stepping motor are built and the relation to other devices, locations, and wiring. Therefore, the user is required to finally check the entire machine and equipment conformity to the EMC Directive

PMAPI1S6A01

PMAPI1S6B01

PMMV-MA-50034

PMM-MA-50064

PMM-BA-5603-5643

PMM-BA-5604-5644

PMDPB1S6P01

PMDPC1S3P01

PMM-MD-53030-53031

PMM-BD-53130-53131

PMDPD1S1P01

PMDPA1C3P50

Standard combined stepping motor

● "STEPSYN H" series that conform to CE Marking

Stepping motor dimensions	Stepping motor model number		Holding torque N·m(oz·in)	Rotor inertia ×10 ⁻⁴ kg·m ² (oz·in ²)	Mass(Weight) kg(lbs)	Page
	Single shaft	Double shaft				
ø60mm	103H7521-6050	103H7521-6020	0.461(6.53)	0.148(0.81)	0.51(1.12)	313 page
	103H7522-6050	103H7522-6020	0.735(104.1)	0.18(0.98)	0.6(1.32)	
	103H7523-6050	103H7523-6020	1.568(222.0)	0.423(2.31)	1.1(2.43)	
ø86mm	103H8581-6050	103H8581-6020	2.06(291.7)	1.45(7.93)	1.5(3.31)	315 page
	103H8582-6050	103H8582-6020	4.02(569.3)	2.9(15.86)	2.5(5.51)	
	103H8583-6050	103H8583-6020	6.17(873.7)	4.4(24.06)	3.5(7.72)	
ø106mm	103H89582-6050	103H89582-6020	10.8(1529.4)	14.6(79.83)	7(15.43)	317 page
	103H89583-6050	103H89583-6020	16(2265.7)	22(120.28)	10.4(22.93)	

• For the general specifications and dimensions of each stepping motor, refer to the reference pages.

● Standard "STEPSYN H" series

Stepping motor dimensions	Stepping motor model number		Holding torque N·m(oz·in)	Rotor inertia ×10 ⁻⁴ kg·m ² (oz·in ²)	Mass(Weight) kg(lbs)	Page
	Single shaft	Double shaft				
□42mm	103H5505-7040	103H5505-7010	0.127(17.98)	0.03(0.16)	0.23(0.51)	301 page
	103H5508-7040	103H5508-7010	0.176(24.92)	0.053(0.29)	0.28(0.62)	
	103H5510-7040	103H5510-7010	0.255(36.11)	0.065(0.36)	0.37(0.82)	
□50mm	103H6500-7041	103H6500-7011	0.235(33.28)	0.057(0.31)	0.38(0.84)	303 page
	103H6501-7041	103H6501-7011	0.39(55.23)	0.105(0.57)	0.44(0.97)	
□60mm	103H7851-7051	103H7851-7021	0.65(92.0)	0.275(1.50)	0.6(1.32)	305 page
	103H7852-7051	103H7852-7021	0.98(138.8)	0.4(2.19)	0.78(1.72)	
	103H7853-7051	103H7853-7021	1.86(263.4)	0.84(4.59)	1.36(3.00)	
ø60mm	103H7521-7051	103H7521-7021	0.461(65.3)	0.148(0.81)	0.51(1.12)	307 page
	103H7522-7051	103H7522-7021	0.735(104.1)	0.18(0.98)	0.6(1.32)	
	103H7523-7051	103H7523-7021	1.568(222.0)	0.423(2.31)	1.1(2.43)	
ø86mm	103H8581-7041	103H8581-7011	2.06(291.7)	1.45(7.93)	1.5(3.31)	309 page
	103H8582-7041	103H8582-7011	4.02(569.3)	2.9(15.86)	2.5(5.51)	
	103H8583-7041	103H8583-7011	6.17(873.7)	4.4(24.06)	3.5(7.72)	
ø106mm	103H89582-7041	103H89582-7011	10.8(1529.4)	14.6(79.83)	7(15.43)	311 page
	103H89583-7041	103H89583-7011	16(2265.7)	22(120.28)	10.4(22.93)	

• For the general specifications and dimensions of each stepping motor, refer to the reference pages.

Parts Recommended for the EMC Directive Conformity

No.	Part name	Model	Specifications and dimensions	Manufacturer
Note 1	Noise filter	RF1015-DLC	Rated voltage: AC 250V, Rated current: 15A	RASMIELECTRONICS LTD.,
Note 2	Toroidal core	T60×20×36	Outer core diameter: 60 mm, Inner core diameter: 36 mm	TDK
Note 3	Toroidal core	TRCN-40-27-15	Outer core diameter: 40 mm, Inner core diameter: 27 mm	Kitagawa Industries Co., Ltd.
Note 4	Toroidal core	TRCN-40-27-15	Outer core diameter: 40 mm, Inner core diameter: 27 mm	Kitagawa Industries Co., Ltd.

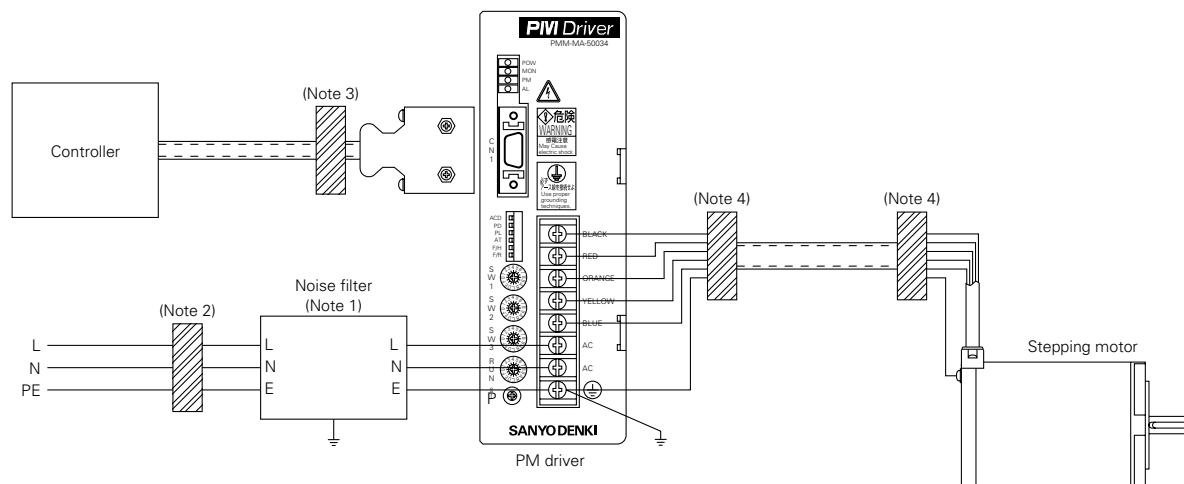
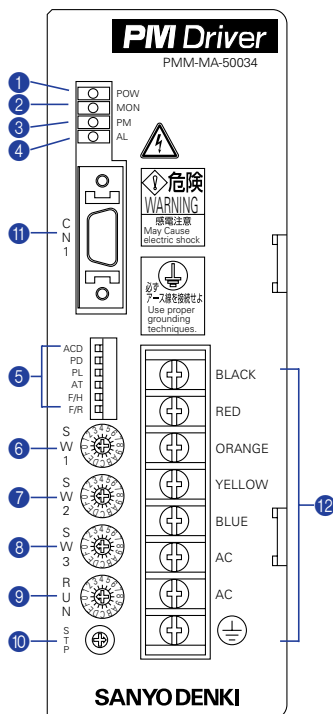

Fig1 Installation environment diagram

Operation, connection, and function

Each section name of the PM driver



- 1 Internal power establishment (POW) Indicates that the internal power is established.
- 2 Phase origin monitor (MON)..... Indicates that the excitation phase is at the origin (in the state when the power is turned ON).
- 3 Input pulse monitor (PM) Indicates that the input pulse is applied.
- 4 Alarm monitor(AL) Turns ON when the internal alarm circuit operates.
- 5 Function selection dipswitch Functions can be selected according to the specification. (ACD,PD,PL,AT,F/H,F/R)
- 6 SW1 (reserved) Not used.
- 7 SW2 (reserved) Not used.
- 8 Half-step angle correction/ Step angle selection switch (SW3)..... corrected or the number of divisions of the micro-step drive is set.
- 9 Operation current selection switch (RUN) Stepping motor current value during ...operation can be selected.
- 10 Stopping current adjustment control (STP) The stepping motor current when stopping is ...adjusted when the automatic current reduction function is operated.
- 11 Connector for I/O signal (CN1) The I/O signal is connected.
- 12 Terminal block (TB) ..I/O signals, the single-phase AC power source, and the stepping motor power cable are connected.

External wiring diagram

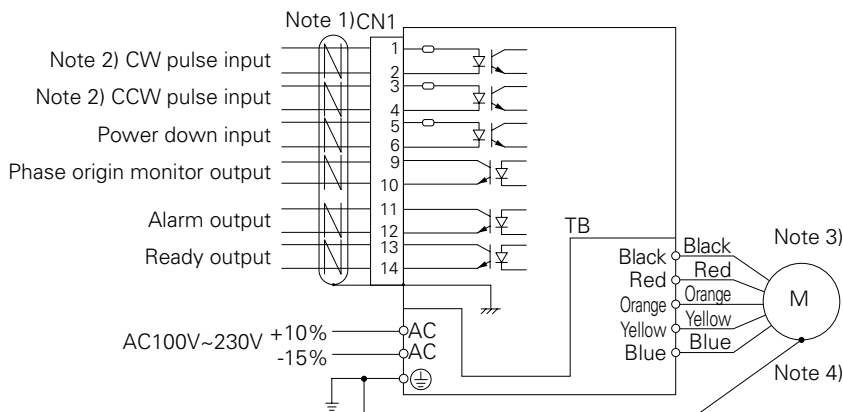

Note 1) Use shielded twisted-pair cables.

Note 2) Either "2-input mode (CW and CCW)" or "Pulse and direction mode (CK and U/D)" can be selected by using the function selection switch F/R

Note3) Refer to the following table when connecting the 103H785□type stepping motor:

Product	Terminal block silk/stepping motor connector pin number				
PM driver (TB)	BLACK	RED	ORANGE	YELLOW	BLUE
Stepping motor connector	1	4	3	2	5

Note 4) Ground the stepping motor flange section and the stepping motor fastening screw by fixing them together when using the standard "STEPSYN H" series. Use the grounding terminal when using the "STEPSYN H" series that conform to CE Marking. Use a single point grounding.

PMAPA1S6A01 PMAPA1S6B01 PMM-MA-50034 PMM-MA-50064 PMM-BA-5603-5643 PMM-BA-5604-5644 PMDPA1S6P01 PMDPC1S3P01 PMM-MD-53030-53031 PMM-BD-53130-53131 PMDPA1C3P50

Operation, connection, and function

● Function selection dipswitch ---⑤

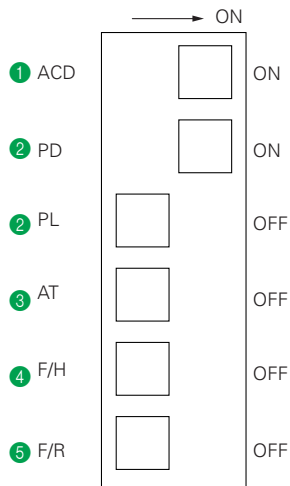

- Settings at the shipment are shown above.
- Turn OFF the PM driver power before changing switch settings to change the function selection dipswitch settings.

① ACD (automatic current reduction selection)

Automatic current reduction function is selected.

ACD	Auto current down
ON	Approx. 50% of current rating when stopped
OFF	100% of current rating when stopped

② PD and PL (power down and power low selection)

The stepping motor windings current value at the power down signal input is selected.

PD	PL	Stepping motor current
ON	OFF	OA (power OFF)
OFF	ON	Adjustment value of the stopping adjustment control STP (power low)

③ AT (automatic micro selection)

(Note)
This switch is not used.
Do not turn ON this switch.

④ F/H (excitation system selection)

(Note)
This switch is not used.
Do not turn ON this switch.

⑤ F/R (pulse input system selection)

A pulse input system is selected.

F/R	Pulse input system
ON	Pulse and direction mode (CK and U/D)
OFF	2-input mode (CW and CCW)

*1) The temperature increase in the motor driver can be controlled by setting ACD to On (approx. 50% of the rated current).

*2) The output torque when ACD is On (approx. 50% of the rated current) is approx. 50% of that when ACD is Off (100% of the rated current).

Operation, connection, and function

● Step angle selection switch (SW3) ---⑧

Number of basic step angle divisions of stepping motor (0.72°C)

Scale	0	1	2	3	4	5	6	7
Number of divisions	1	2	2.5	4	5	8	10	20
Scale	8	9	A	B	C	D	E	F
Number of divisions	25	40	50	80	100	125	200	250

- "4" is set at the shipment (distribution ratio "5:5" or number of divisions "5").

● Operation current selection switch (RUN) ---⑨

Operation current of stepping motor can be selected.

Scale	0	1	2	3	4	5	6	7
Stepping motor current (A total)	3.0	2.9	2.8	2.6	2.5	2.4	2.3	2.2
Scale	8	9	A	B	C	D	E	F
Stepping motor current (A total)	2.1	1.9	1.8	1.7	1.6	1.5	1.3	1.2

- "0" is set at the shipment.
- 0.75 A/phase is set at scale 0.

● SW1, SW2 (reserved) ---⑥, ⑦

This rotary switch is not used.

● Stopping current adjustment control (STP) ---⑩

The stepping motor current value is adjusted for the stopping operation in the automatic current reduction function and when the power down input signal is set to "ON" (power low function is selected by dipswitches).

- Approx. 50% operation current value selected by RUN is set at the shipment.
- For the STP adjustment, refer to the separate PMM-MA-50034-10 operations manual.

● I/O signal function (CN1) ---⑪

Signal name	Abbreviation	Pin Number	Function
CW pulse input (standard)	CW+	1	When using "2-input mode"
	CW-	2	Drive pulse for the CW direction rotation is input.
Pulse column input	CK+	1	When using "Pulse and direction mode"
	CK-	2	Drive pulse train for the stepping motor rotation is input.
CCW pulse input (standard)	CCW+	3	When using "2-input mode"
	CCW-	4	Drive pulse for the CCW direction rotation is input.
Rotation direction input	U/D ⁺	3	The rotation direction signal of stepping motor is input for the "Pulse and direction mode". Internal photocoupler ON CW direction
	U/D ⁻	4	Internal photocoupler OFF CCW direction
Power down input	PD+	5	Inputting the PD signal cuts OFF the current flowing through the stepping motor (turns OFF the power). (The power down input can be changed to the power low function by selecting dipswitches.)
	PD-	6	PD input signal ON (internal photocoupler ON) PD function enabled PD input signal OFF (internal photocoupler OFF) PD function disabled
Phase origin monitor output	MON (collector)	9	It is turned ON when the excitation phase is at the origin (in the state when the power is turned ON).
	MON (emitter)	10	It is turned ON once per 10 pulses when setting to 2-division (full step). It is turned ON once per 20 pulses when setting to 1-division (half step).
Alarm output	AL (collector)	11	The signal is externally output when one of several alarm circuits operates in the PM driver.
	AL (emitter)	12	At this time, the stepping motor is in the unexcited state.
Ready output	RDY (collector)	13	It is turned ON and OFF when the stepping motor is in the excitation state and the unexcited state, respectively.
	RDY (emitter)	14	

- The CW direction of stepping motor means the clockwise direction rotation as viewed from the output shaft side (flange side). The CCW direction means the counterclockwise direction rotation as viewed from the output shaft side (flange side).

PMAPAI1S6A01
PMAPAI1S6B01
PMMV-MA-50034
PMM-MA-50064
PMM-BA-5603-5643
PMM-BA-5604-5644
PMDPB1S6P01
PMDPC1S3P01
PMM-MD-53030-53031
PMM-BD-53130-53131
PMDPD1S1P01
PMDPA1C3P50

Operation, connection, and function

● Arrangement of the connector terminals (CN1)

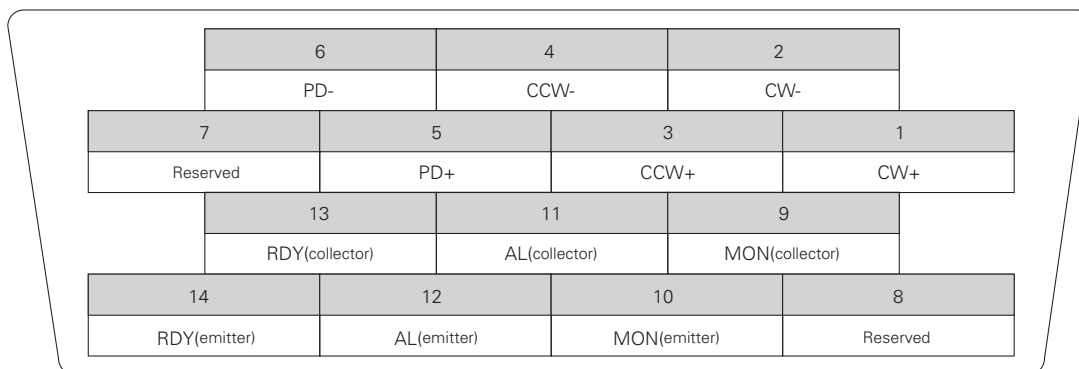

Arrangement of the CN1 connector terminals

* The chart shown above is viewed from the connection section of the connector plug.

● Connectors to be used

PM driver side		Applicable connector model number	Manufacturer
Used for	Model number		
I/O signal (CN1)	10214-52A2JL	Applicable plug:10114-3000VE- Applicable shell:10314-52A0-008	Sumitomo 3M

- The applicable connectors are attached.

Operation, connection, and function

Input circuit configuration (CW and CCW)

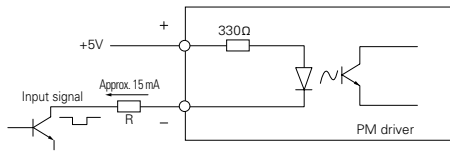

- Pulse duty is 50 % MAX.
- When the peak value of the input signal is 5V, the external limit resistance R is 0 Ω. If the peak value exceeds 5V, set the input current to approx. 15mA using the external limit resistance R.

Input signal specifications

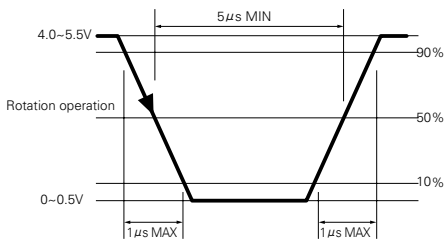

Timing of the command pulse

• 2-input mode (CW and CCW)

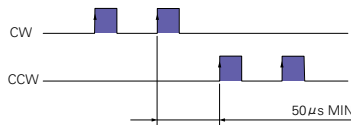

- The internal photocoupler turns ON at [blue square], and the internal circuit (stepping motor) operates at the leading edge of the photocoupler "ON".
- When applying the pulse to CW, set the internal photocoupler on the CCW side to "OFF".
- When applying the pulse to CCW, set the internal photocoupler on the CW side to "OFF".

• Pulse and direction mode (CK and U/D)

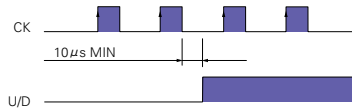

- The internal photocoupler turns ON at [blue square], and the internal circuit (stepping motor) operates at the leading edge of the CK photocoupler "ON".
- Before switching the U/D input signals, turn OFF the internal photocoupler on the CK side.

Input circuit configuration (PD)

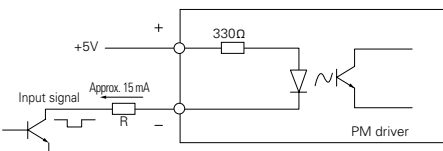

- When the peak value of the input signal is 5V, the external limit resistance R is 0 Ω. If the peak value exceeds 5V, set the input current to approx. 15mA using the external limit resistance R.

PMAPI1S6A01

PMAPI1S6B01

PMM-MA-50034

PMM-MA-50064

PMM-BA-5603-5643

PMM-BA-5604-5644

PMDPB1S6P01

PMDPC1S3P01

PMM-MD-53030-53031

PMM-BD-53130-53131

PMDPD1S1P01

PMDPA1C3P50

Operation, connection, and function

● Output circuit configuration (MON, AL, RDY)

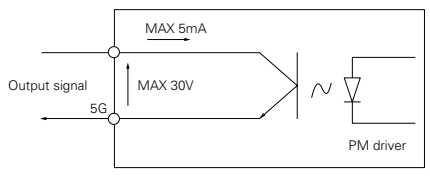

- MON, AL, RDY output signal
- Contact type: Open collector output by the photocoupler
- Contact capacity: DC 30 V, 5 mA MAX

Timing of the MON output (when 1-division is specified)

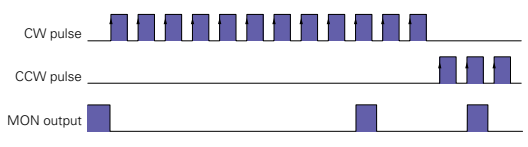

- The internal photocoupler turns "ON" at [MON pulse]

● State Indication (LED)

Indication	Color	Explanation
POW turns ON.	Green	Internal power has been established.
MON turns ON.	Green	Excitation phase is at the origin (the power is turned on). When 1-division is specified (full step), turns on once in 10 pulses. When 2-division is specified (half step), turns on once in 20 pulses. Command pulse is input.
PM turns ON.	Green	Turns on for Approx. 100ms for every one pulse input. Timing of MON illumination (1-division setting)

Timing of MON illumination (1-division setting)

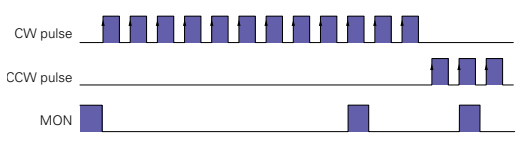

- The internal photocoupler turns "ON" at [MON pulse]

● Alarm Indication (LED)

Indication	Color	Explanation
AL turns on.	Red	The overheat protection alarm circuit of the internal device operates. The circuit operates when both the internal temperature of the PM driver and the ambient temperature become 80°c MIN.

- Each alarm circuit operation turns on the alarm LED and cuts off the stepping motor current to result in the unexcited state. At the same time, the alarm output circuit photocoupler of I/O signal connector (CN1) turns ON and the signal is output externally. The alarm automatically stops to turn ON the stepping motor current when the internal semiconductor temperature becomes 80°c MAX. Turn OFF the main power and try to radiate the generated heat by the forced-air-cooling of PM driver cabinet and so on before the automatic recovery from the alarm state when an alarm occurs.

Pulse rate-torque characteristics/pulse rate-source current characteristics

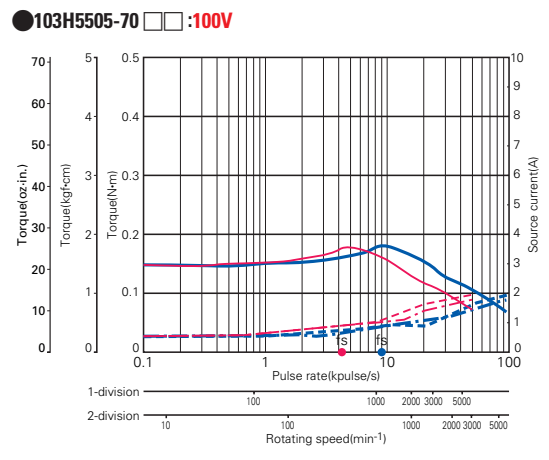

Source voltage: AC100V-Operating current: 0.75A/phase
 — Pull-out torque(JL1=0.94×10⁻⁴kg·m² [5.14 oz-in²] Use the rubber coupling)
 - - - Source current(T_L=MAX) - - - Source current(T_L=0)
 fs: No load maximum starting pulse rate
 ■ 1-division is specified ■ 2-division is specified

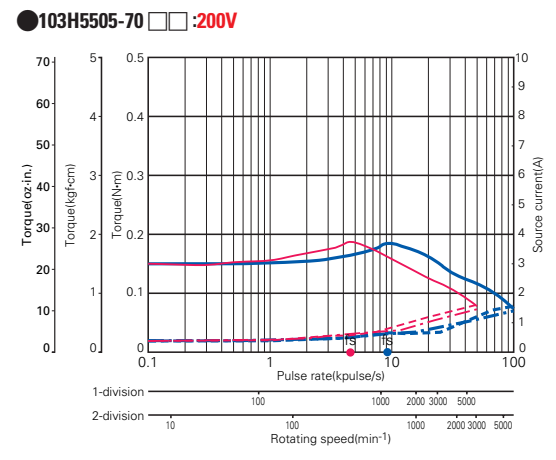

Source voltage: AC200V-Operating current: 0.75A/phase
 — Pull-out torque(JL1=0.94×10⁻⁴kg·m² [5.14 oz-in²] Use the rubber coupling)
 - - - Source current(T_L=MAX) - - - Source current(T_L=0)
 fs: No load maximum starting pulse rate
 ■ 1-division is specified ■ 2-division is specified

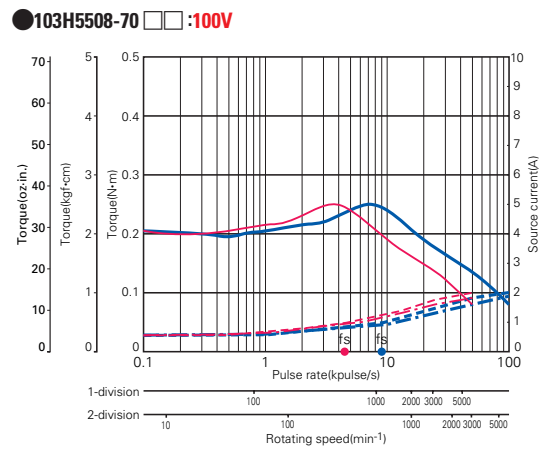

Source voltage: AC100V-Operating current: 0.75A/phase
 — Pull-out torque(JL1=0.94×10⁻⁴kg·m² [5.14 oz-in²] Use the rubber coupling)
 - - - Source current(T_L=MAX) - - - Source current(T_L=0)
 fs: No load maximum starting pulse rate
 ■ 1-division is specified ■ 2-division is specified

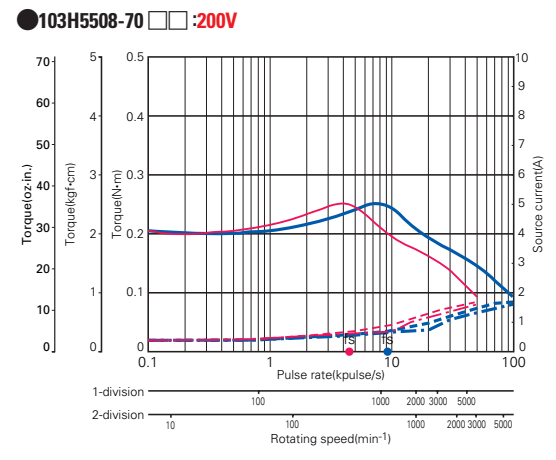

Source voltage: AC200V-Operating current: 0.75A/phase
 — Pull-out torque(JL1=0.94×10⁻⁴kg·m² [5.14 oz-in²] Use the rubber coupling)
 - - - Source current(T_L=MAX) - - - Source current(T_L=0)
 fs: No load maximum starting pulse rate
 ■ 1-division is specified ■ 2-division is specified

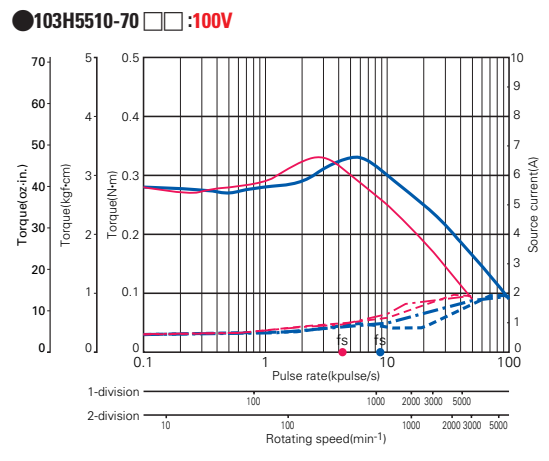

Source voltage: AC100V-Operating current: 0.75A/phase
 — Pull-out torque(JL1=0.94×10⁻⁴kg·m² [5.14 oz-in²] Use the rubber coupling)
 - - - Source current(T_L=MAX) - - - Source current(T_L=0)
 fs: No load maximum starting pulse rate
 ■ 1-division is specified ■ 2-division is specified

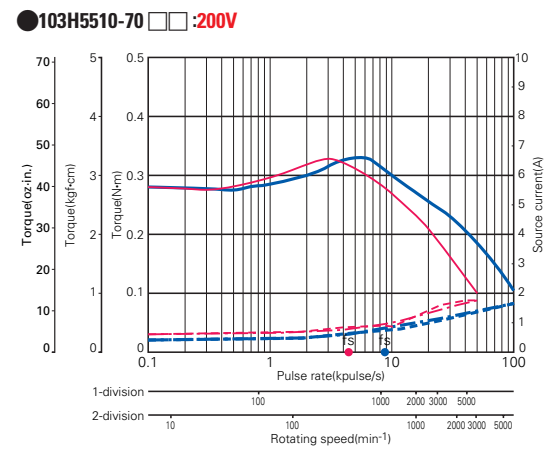

Source voltage: AC200V-Operating current: 0.75A/phase
 — Pull-out torque(JL1=0.94×10⁻⁴kg·m² [5.14 oz-in²] Use the rubber coupling)
 - - - Source current(T_L=MAX) - - - Source current(T_L=0)
 fs: No load maximum starting pulse rate
 ■ 1-division is specified ■ 2-division is specified

Pulse rate-torque characteristics/pulse rate-source current characteristics

●103H6500-70 □□:100V

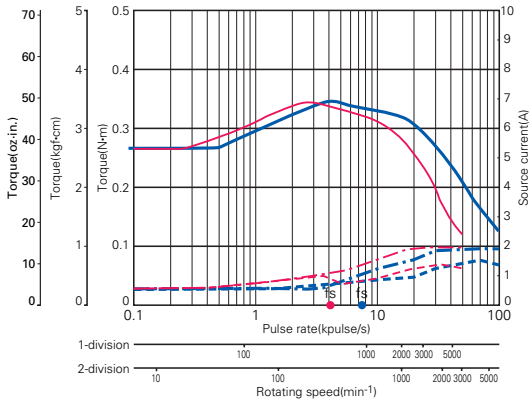

Source voltage:AC100V.Operating current: 0.75A/phase
 — Pull-out torque(JL1=0.94x10⁻⁴kg-m² [5.14 oz-in²] Use the rubber coupling)
 - - - Source current(TL=MAX) - - - Source current(TL=0)
 fs:No load maximum starting pluse rate
 ■ 1-division is specified ■ 2-division is specified

●103H6500-70 □□:200V

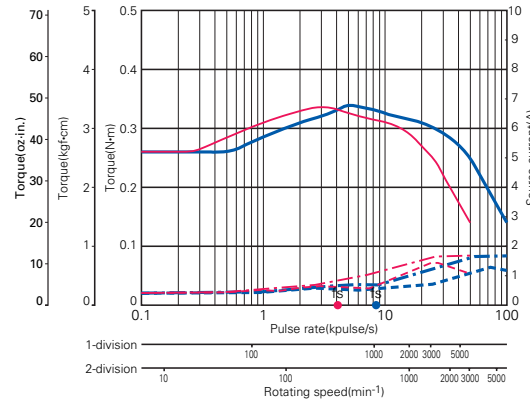

Source voltage:AC200V.Operating current: 0.75A/phase
 — Pull-out torque(JL1=0.94x10⁻⁴kg-m² [5.14 oz-in²] Use the rubber coupling)
 - - - Source current(TL=MAX) - - - Source current(TL=0)
 fs:No load maximum starting pluse rate
 ■ 1-division is specified ■ 2-division is specified

●103H6501-70 □□:100V

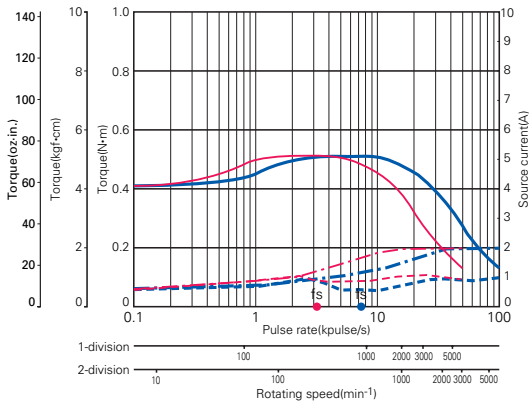

Source voltage:AC100V.Operating current: 0.75A/phase
 — Pull-out torque(JL1=0.94x10⁻⁴kg-m² [5.14 oz-in²] Use the rubber coupling)
 - - - Source current(TL=MAX) - - - Source current(TL=0)
 fs:No load maximum starting pluse rate
 ■ 1-division is specified ■ 2-division is specified

●103H6501-70 □□:200V

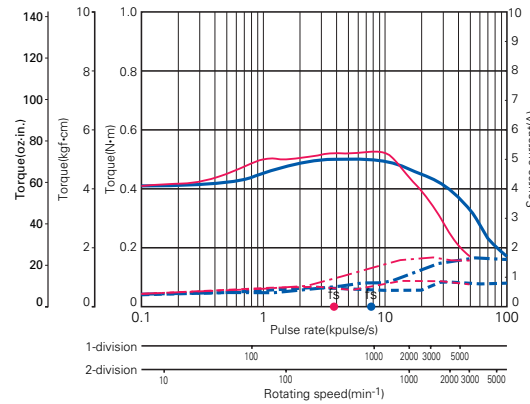

Source voltage:AC200V.Operating current: 0.75A/phase
 — Pull-out torque(JL1=0.94x10⁻⁴kg-m² [5.14 oz-in²] Use the rubber coupling)
 - - - Source current(TL=MAX) - - - Source current(TL=0)
 fs:No load maximum starting pluse rate
 ■ 1-division is specified ■ 2-division is specified

●103H7851-70 □□:100V

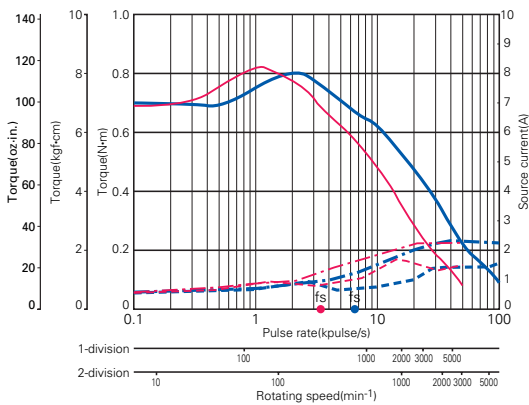

Source voltage:AC100V.Operating current: 0.75A/phase
 — Pull-out torque(JL1=2.6x10⁻⁴kg-m² [14.22 oz-in²] Use the rubber coupling)
 - - - Source current(TL=MAX) - - - Source current(TL=0)
 fs:No load maximum starting pluse rate
 ■ 1-division is specified ■ 2-division is specified

●103H7851-70 □□:200V

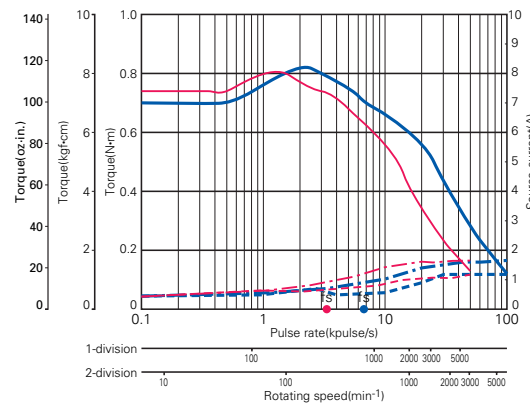

Source voltage:AC200V.Operating current: 0.75A/phase
 — Pull-out torque(JL1=2.6x10⁻⁴kg-m² [14.22 oz-in²] Use the rubber coupling)
 - - - Source current(TL=MAX) - - - Source current(TL=0)
 fs:No load maximum starting pluse rate
 ■ 1-division is specified ■ 2-division is specified

PMAPA1S6A01
 PMAPA1S6B01
 PMM-MA-50034
 PMM-MA-50064
 PMM-BA-5603-9643
 PMM-BA-5604-9644
 PMDPA1S6P01
 PMDPC1S3P01
 PMM-MD-53030-53031
 PMM-BD-53130-53131
 PMDPA1S1P01
 PMDPA1C3P50

Pulse rate-torque characteristics/pulse rate-source current characteristics

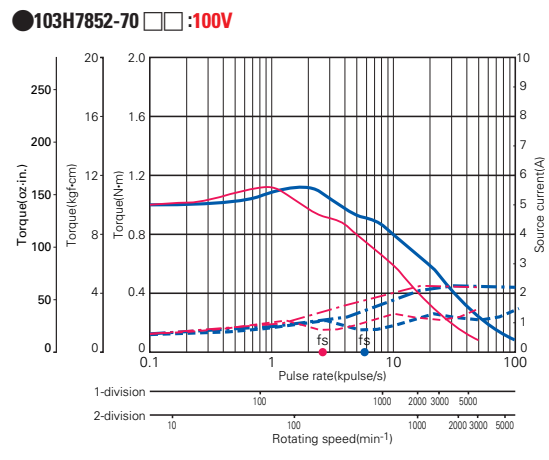

●103H7852-70 □□ :100V
 Source voltage:AC100V-Operating current: 0.75A/phase
 — Pull-out torque(JL1=2.6×10⁻⁴kg-m² [14.22 oz-in²] Use the rubber coupling)
 - - - Source current(T_L=MAX) - - - Source current(T_L=0)
 fs:No load maximum starting pulse rate
 ■ 1-division is specified ■ 2-division is specified

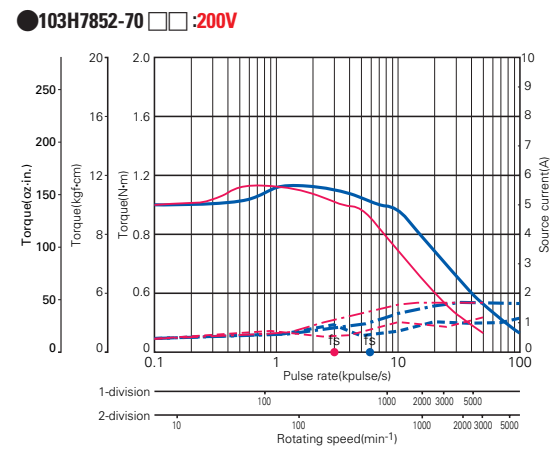

●103H7852-70 □□ :200V
 Source voltage:AC200V-Operating current: 0.75A/phase
 — Pull-out torque(JL1=2.6×10⁻⁴kg-m² [14.22 oz-in²] Use the rubber coupling)
 - - - Source current(T_L=MAX) - - - Source current(T_L=0)
 fs:No load maximum starting pulse rate
 ■ 1-division is specified ■ 2-division is specified

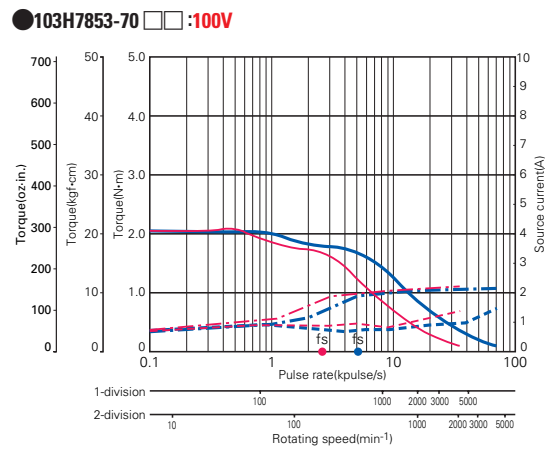

●103H7853-70 □□ :100V
 Source voltage:AC100V-Operating current: 0.75A/phase
 — Pull-out torque(JL1=7.4×10⁻⁴kg-m² [40.46 oz-in²] Use the rubber coupling)
 - - - Source current(T_L=MAX) - - - Source current(T_L=0)
 fs:No load maximum starting pulse rate
 ■ 1-division is specified ■ 2-division is specified

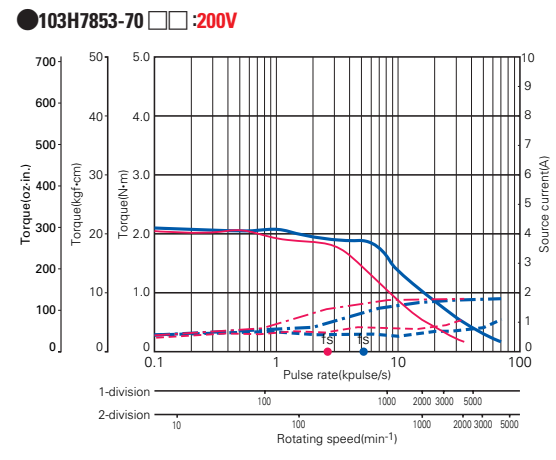

●103H7853-70 □□ :200V
 Source voltage:AC200V-Operating current: 0.75A/phase
 — Pull-out torque(JL1=7.4×10⁻⁴kg-m² [40.46 oz-in²] Use the rubber coupling)
 - - - Source current(T_L=MAX) - - - Source current(T_L=0)
 fs:No load maximum starting pulse rate
 ■ 1-division is specified ■ 2-division is specified

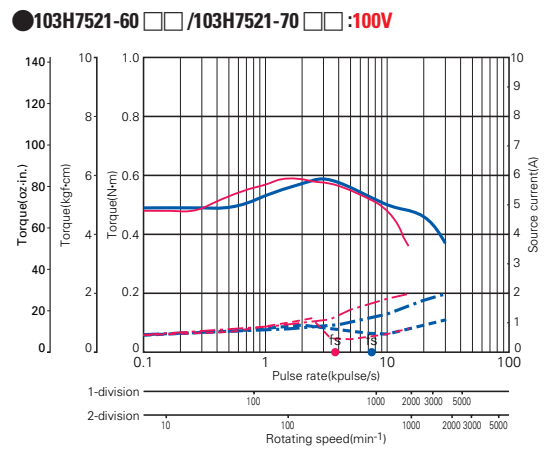

●103H7521-60 □□ /103H7521-70 □□ :100V
 Source voltage:AC100V-Operating current: 0.75A/phase
 — Pull-out torque(JL1=0.94×10⁻⁴kg-m² [5.14 oz-in²] Use the rubber coupling)
 - - - Source current(T_L=MAX) - - - Source current(T_L=0)
 fs:No load maximum starting pulse rate
 ■ 1-division is specified ■ 2-division is specified

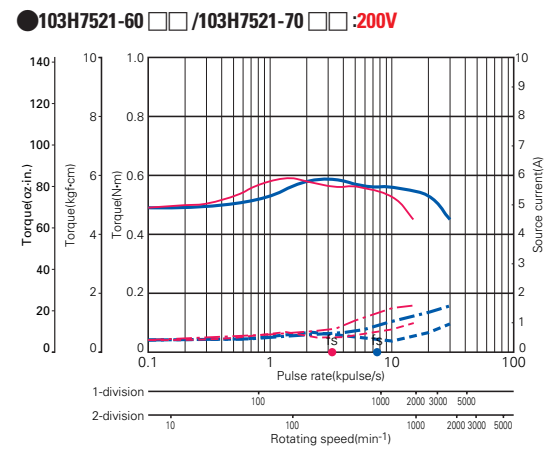

●103H7521-60 □□ /103H7521-70 □□ :200V
 Source voltage:AC200V-Operating current: 0.75A/phase
 — Pull-out torque(JL1=0.94×10⁻⁴kg-m² [5.14 oz-in²] Use the rubber coupling)
 - - - Source current(T_L=MAX) - - - Source current(T_L=0)
 fs:No load maximum starting pulse rate
 ■ 1-division is specified ■ 2-division is specified



Pulse rate-torque characteristics/pulse rate-source current characteristics

● 103H7522-60 □□ /103H7522-70 □□ :100V

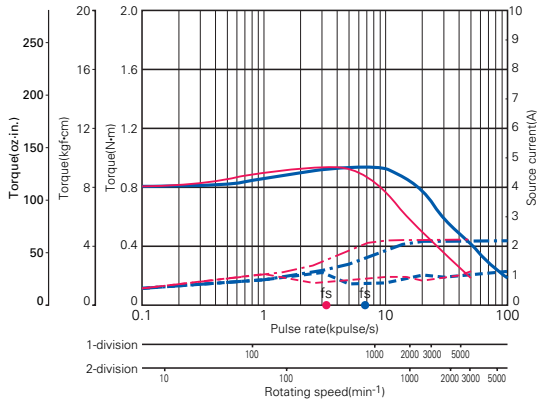

Source voltage:AC100V.Operating current: 0.75A/phase
 — Pull-out torque(JL1=2.6×10⁻⁴kg·m² [14.22 oz-in²] Use the rubber coupling)
 - - - Source current(T_L=MAX) - - - Source current(T_L=0)
 fs:No load maximum starting pulse rate
 ■ 1-division is specified ■ 2-division is specified

● 103H7522-60 □□ /103H7522-70 □□ :200V

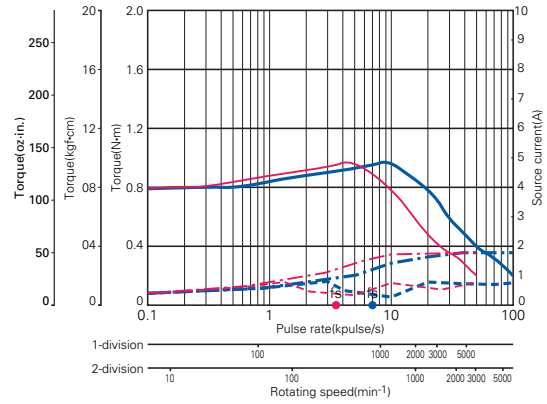

Source voltage:AC200V.Operating current: 0.75A/phase
 — Pull-out torque(JL1=2.6×10⁻⁴kg·m² [14.22 oz-in²] Use the rubber coupling)
 - - - Source current(T_L=MAX) - - - Source current(T_L=0)
 fs:No load maximum starting pulse rate
 ■ 1-division is specified ■ 2-division is specified

● 103H7523-60 □□ /103H7523-70 □□ :100V

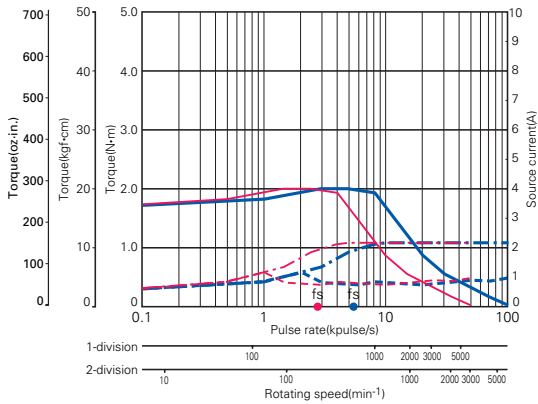

Source voltage:AC100V.Operating current: 0.75A/phase
 — Pull-out torque(JL1=7.4×10⁻⁴kg·m² [40.46 oz-in²] Use the rubber coupling)
 - - - Source current(T_L=MAX) - - - Source current(T_L=0)
 fs:No load maximum starting pulse rate
 ■ 1-division is specified ■ 2-division is specified

● 103H7523-60 □□ /103H7523-70 □□ :200V

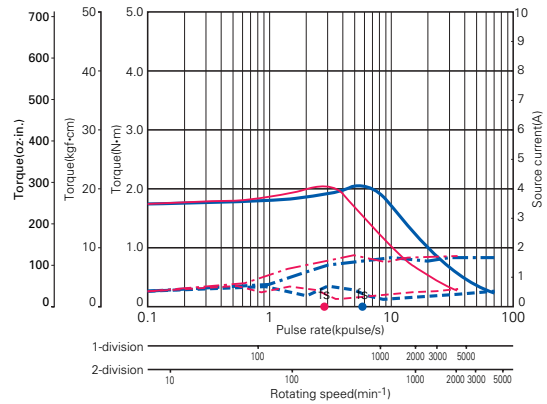

Source voltage:AC200V.Operating current: 0.75A/phase
 — Pull-out torque(JL1=7.4×10⁻⁴kg·m² [40.46 oz-in²] Use the rubber coupling)
 - - - Source current(T_L=MAX) - - - Source current(T_L=0)
 fs:No load maximum starting pulse rate
 ■ 1-division is specified ■ 2-division is specified

● 103H8581-60 □□ /103H8581-70 □□ :100V

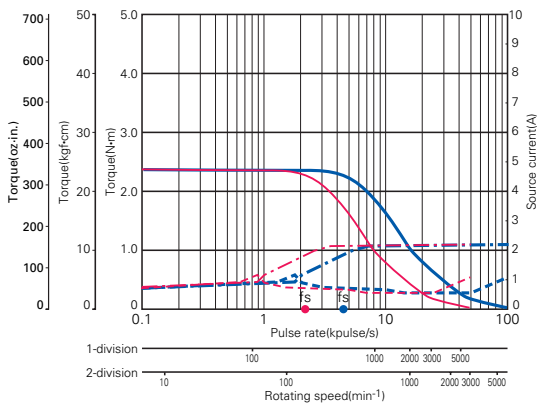

Source voltage:AC100V.Operating current: 0.75A/phase
 — Pull-out torque(JL1=7.4×10⁻⁴kg·m² [40.46 oz-in²] Use the rubber coupling)
 - - - Source current(T_L=MAX) - - - Source current(T_L=0)
 fs:No load maximum starting pulse rate
 ■ 1-division is specified ■ 2-division is specified

● 103H8581-60 □□ /103H8581-70 □□ :200V

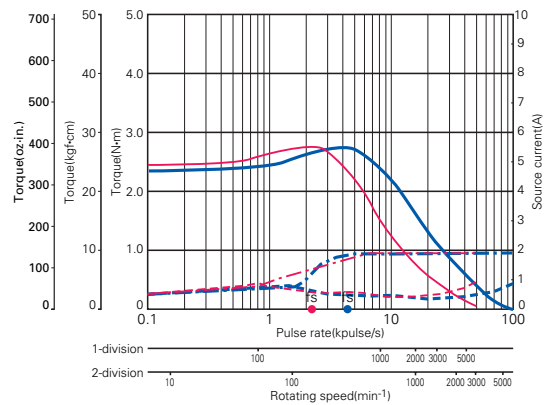

Source voltage:AC200V.Operating current: 0.75A/phase
 — Pull-out torque(JL1=7.4×10⁻⁴kg·m² [40.46 oz-in²] Use the rubber coupling)
 - - - Source current(T_L=MAX) - - - Source current(T_L=0)
 fs:No load maximum starting pulse rate
 ■ 1-division is specified ■ 2-division is specified

PMAPA1S6A01

PMAPA1S6B01

PMIM-MA-50034

PMIM-MA-50064

PMIM-BA-5603

-5643

PMIM-BA-5604

-5644

PMIDPB1S6P01

PMIDPC1S3P01

PMIM-MD-53030

-53031

PMIM-BD-53130

-53131

PMIDPB1S1P01

PMIDPA1C3P50

Pulse rate-torque characteristics/pulse rate-source current characteristics

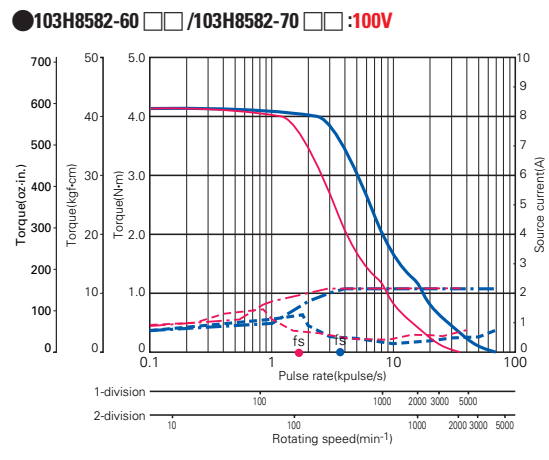

Source voltage: AC100V-Operating current: 0.75A/phase
 — Pull-out torque(JL1=15.3×10⁻⁴kg·m² [83.65 oz-in²] Use the rubber coupling)
 - - - Source current(T_L=MAX) - - - Source current(T_L=0)
 fs: No load maximum starting pulse rate
 ■ 1-division is specified ■ 2-division is specified

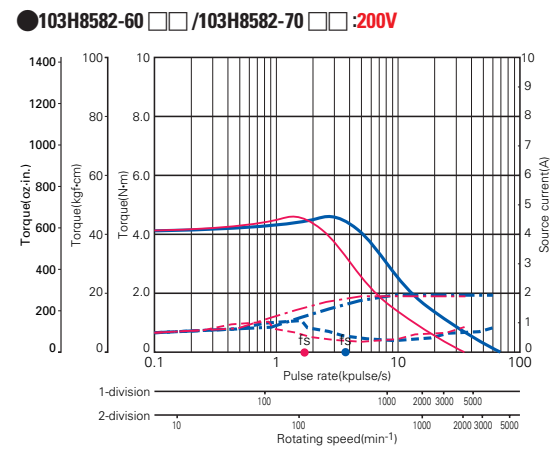

Source voltage: AC200V-Operating current: 0.75A/phase
 — Pull-out torque(JL1=15.3×10⁻⁴kg·m² [83.65 oz-in²] Use the rubber coupling)
 - - - Source current(T_L=MAX) - - - Source current(T_L=0)
 fs: No load maximum starting pulse rate
 ■ 1-division is specified ■ 2-division is specified

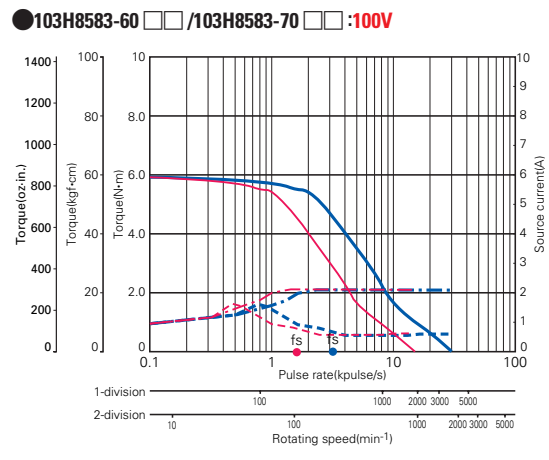

Source voltage: AC100V-Operating current: 0.75A/phase
 — Pull-out torque(JL1=43×10⁻⁴kg·m² [235.10 oz-in²] Use the rubber coupling)
 - - - Source current(T_L=MAX) - - - Source current(T_L=0)
 fs: No load maximum starting pulse rate
 ■ 1-division is specified ■ 2-division is specified

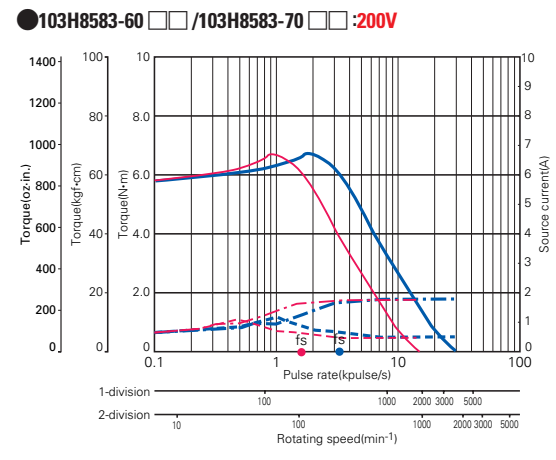

Source voltage: AC200V-Operating current: 0.75A/phase
 — Pull-out torque(JL1=43×10⁻⁴kg·m² [235.10 oz-in²] Use the rubber coupling)
 - - - Source current(T_L=MAX) - - - Source current(T_L=0)
 fs: No load maximum starting pulse rate
 ■ 1-division is specified ■ 2-division is specified

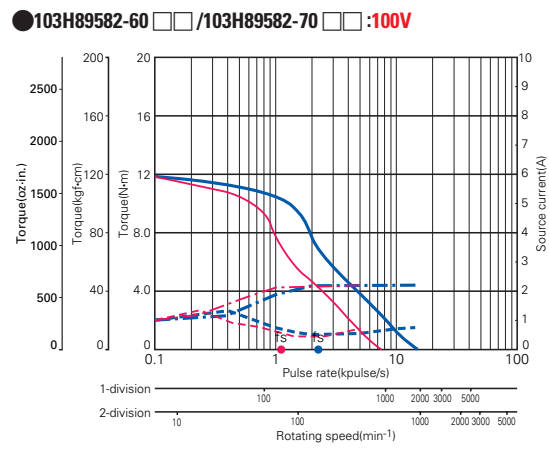

Source voltage: AC100V-Operating current: 0.75A/phase
 — Pull-out torque(JL1=43×10⁻⁴kg·m² [235.10 oz-in²] Use the rubber coupling)
 - - - Source current(T_L=MAX) - - - Source current(T_L=0)
 fs: No load maximum starting pulse rate
 ■ 1-division is specified ■ 2-division is specified

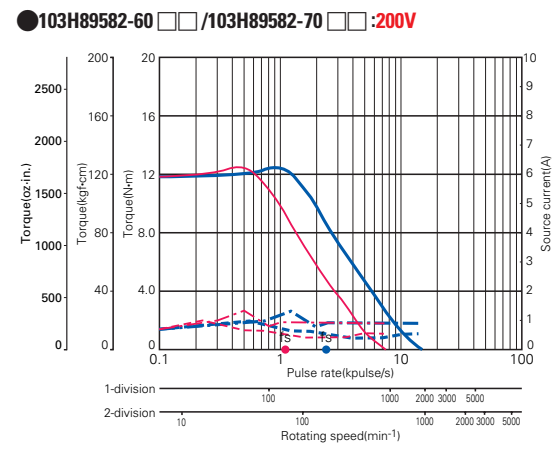

Source voltage: AC200V-Operating current: 0.75A/phase
 — Pull-out torque(JL1=43×10⁻⁴kg·m² [235.10 oz-in²] Use the rubber coupling)
 - - - Source current(T_L=MAX) - - - Source current(T_L=0)
 fs: No load maximum starting pulse rate
 ■ 1-division is specified ■ 2-division is specified

Pulse rate-torque characteristics/pulse rate-source current characteristics

●103H89583-60 □□/103H89583-70 □□ :100V

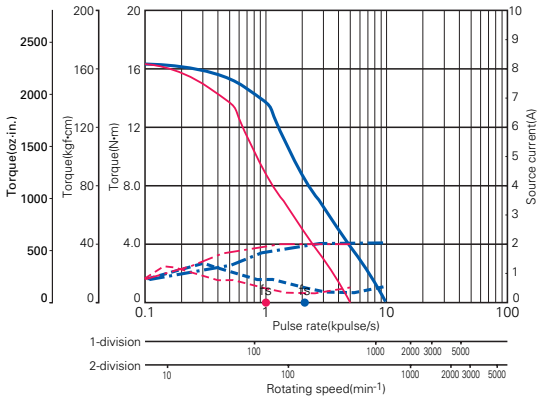

Source voltage:AC100V.Operating current: 0.75A/phase
 — Pull-out torque(JL1=43×10⁻⁴kg·m² [235.10 oz·in²] Use the rubber coupling)
 - - - Source current(T_L=MAX) - - - Source current(T_L=0)
 fs:No load maximum starting pluse rate
 ■ 1-division is specified ■ 2-division is specified

●103H89583-60 □□/103H89583-70 □□ :200V

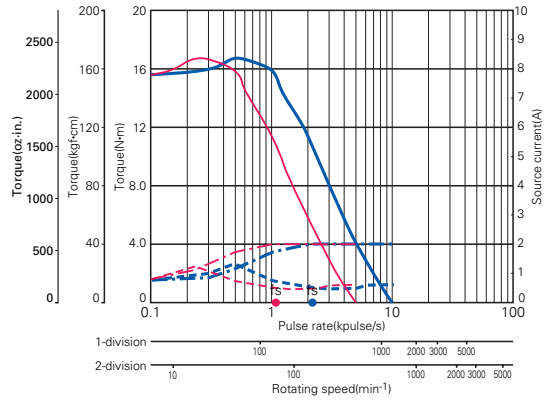

Source voltage:AC200V.Operating current: 0.75A/phase
 — Pull-out torque(JL1=43×10⁻⁴kg·m² [235.10 oz·in²] Use the rubber coupling)
 - - - Source current(T_L=MAX) - - - Source current(T_L=0)
 fs:No load maximum starting pluse rate
 ■ 1-division is specified ■ 2-division is specified

Option

● Fitting metals

Model number	Quantity
PM-AP-001	One set

- The fitting metal can be commonly used for either front or back surface.

● Terminal block cover

Model number	Quantity
PM-AP-015	One

● Connector cable

Model number	Application
PM-C14S0100-02	Connector cable for I/O signals (CN1)

- The connector cable is a 1-meter cable assembled with the connector.

● Cable 1 (I/O signal cable)

Driver side	
Pin number	Color
1	Red
2	Red*
3	Black
4	Black*
5	Green
6	Green*
7	Orange
8	Orange*
9	Blue
10	Blue*
11	Brown
12	Brown*
13	Yellow
14	Yellow*

*: White spiral

Cable model number	Length
PM-C14S0100-02	1m

PMAPA1S6A01
 PMAPA1S6B01
 PMIM-MA-50034
 PMIM-MA-50064
 PMIM-BA-5603-5643
 PMIM-BA-5604-5644
 PMDPPB1S6P01
 PMDPC1S3P01
 PMIM-MD-53030-53031
 PMIM-BD-53130-53131
 PMDPA1C3P50