



() Preliminary Specification

(V) Final Specification

Module	23.8" Color TFT-LCD
Model Name	G238HAN01.1

Customer	Date
_____	_____
Approved by	
_____	_____

Note: This Specification is subject to change without notice.

Approved by	Date
<i>Flossie Chuang</i>	<u>2018.11.26</u>
Prepared by	Date
<i>Tim Li</i>	<u>2018.11.26</u>

AU Optronics corporation

2 General Description

This specification applies to the 23.8 inch wide Color a-Si TFT-LCD Module G238HAN01.1. The display supports the Full HD - 1920(H) x 1080(V) screen format and 16.7M colors. The input interface is dual channel LVDS and this module doesn't contain an driver board for backlight.

2.1 Display Characteristics

The following items are characteristics summary on the table under 25°C condition:

ITEMS	Unit	SPECIFICATIONS
Screen Diagonal	[mm]	604.70 (23.81")
Active Area	[mm]	527.04(H) x 296.46(V)
Pixels H x V	-	1920(x3) x 1080
Pixel Pitch	[um]	274.5 (per one triad) x274.5
Pixel Arrangement	-	R.G.B. Vertical Stripe
Display Mode	-	AHVA, normally Black
White Luminance (Center)	[cd/m ²]	400 (Typ.)
Contrast Ratio	-	1000 (Typ.)
Response Time	[msec]	14 (G to G)
Power Consumption (LCD Module + Backligh unit)	[Watt]	20.7 (Typ.) LCD module : PDD (Typ.)=4.6 @ White pattern,Fv=60Hz Backlight unit : P _{BLU} (Typ.) =16.1 @ Is=70mA
Weight	[Grams]	2300 (typ.)
Outline Dimension	[mm]	543.0(H) x 317.4(V) x 11.2(D) (Typ.)
Electrical Interface	-	Dual channel LVDS
Support Color	-	16.7M colors (RGB 8-bit)
Surface Treatment	-	Anti-Glare, 3H
Temperature Range		
Operating	[°C]	0 to +50
Storage (Shipping)	[°C]	-20 to +60
RoHS Compliance	-	RoHS Compliance
TCO Compliance	-	TCO 6.0 Compliance

2.2 Absolute Maximum Rating of Environment

Permanent damage may occur if exceeding the following maximum rating.

Symbol	Description	Min.	Max.	Unit	Remark
TOP	Operating Temperature	0	+50	[°C]	Note 2-1
TGS	Glass surface temperature (operation)	0	+65	[°C]	Note 2-1 Function judged only
HOP	Operation Humidity	5	90	[%RH]	Note 2-1
TST	Storage Temperature	-20	+60	[°C]	
HST	Storage Humidity	5	90	[%RH]	

Note 2-1: Temperature and relative humidity range are shown as the below figure.

1. 90% RH Max ($T_a \leq 39^\circ\text{C}$)
2. Max wet-bulb temperature at 39°C or less. ($T_a \leq 39^\circ\text{C}$)
3. No condensation

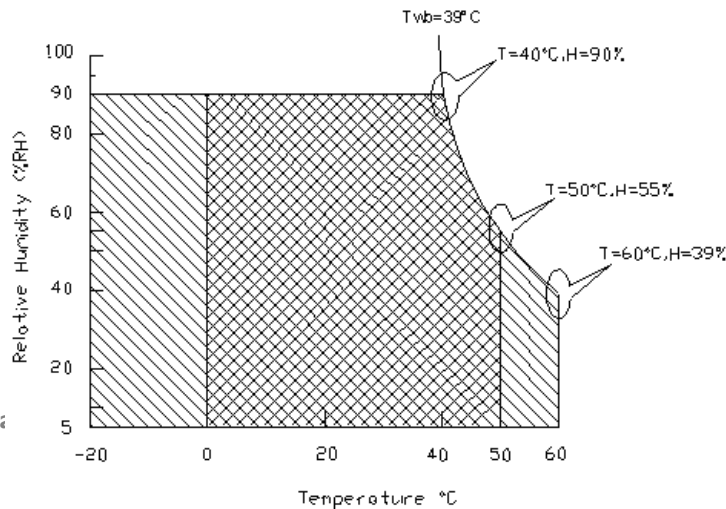

AUO-Gener

Operating Range



Storage Range

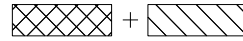

2.3 Optical Characteristics

The optical characteristics are measured on the following test condition.

Test Condition:

1. Equipment setup: Please refer to **Note 2-2**.
2. Panel Lighting time: 30 minutes
3. VDD=5.0V, Fv=60Hz, Is=70mA, Ta=25°C

Symbol	Description		Min.	Typ.	Max.	Unit	Remark
L _w	White Luminance (Center of screen)		320	400	-	[cd/m ²]	Note 2-2 By SR-3
L _{uni}	Luminance Uniformity (9 points)		75	80	-	[%]	Note 2-3 By SR-3
CR	Contrast Ratio (Center of screen)		600	1000	-	-	Note 2-4 By SR-3
θ _R	Horizontal Viewing Angle (CR=10)	Right	75	89	-	[degree]	Note 2-5 By SR-3
θ _L		Left	75	89	-		
Φ _H	Vertical Viewing Angle (CR=10)	Up	75	89	-		
Φ _L		Down	75	89	-		
T _{GTG}	Response Time	Gray to Gray	-	14	-	[msec]	Note 2-6 By TRD-100
R _x	Color Coordinates (CIE 1931)	Red x	0.6	0.63	0.66	-	By SR-3
R _y		Red y	0.302	0.332	0.362		
G _x		Green x	0.278	0.308	0.338		
G _y		Green y	0.582	0.612	0.642		
B _x		Blue x	0.129	0.159	0.189		
B _y		Blue y	0.026	0.056	0.086		
W _x		White x	0.283	0.313	0.343		
W _y		White y	0.299	0.329	0.359		
CT	Crosstalk		-	-	1.5	[%]	Note 2-7 By SR-3
F _{dB}	Flicker (Center of screen)		-	-	-20	[dB]	Note 2-8 By SR-3

AUO-Gen

Note 2-2: Equipment setup :

The LCD module should be stabilized at given temperature for 30 minutes to avoid abrupt temperature change during measuring (at surface 35°C). In order to stabilize the luminance, the measurement should be executed after lighting Backlight for 30 minutes in a stable, windless and dark room.

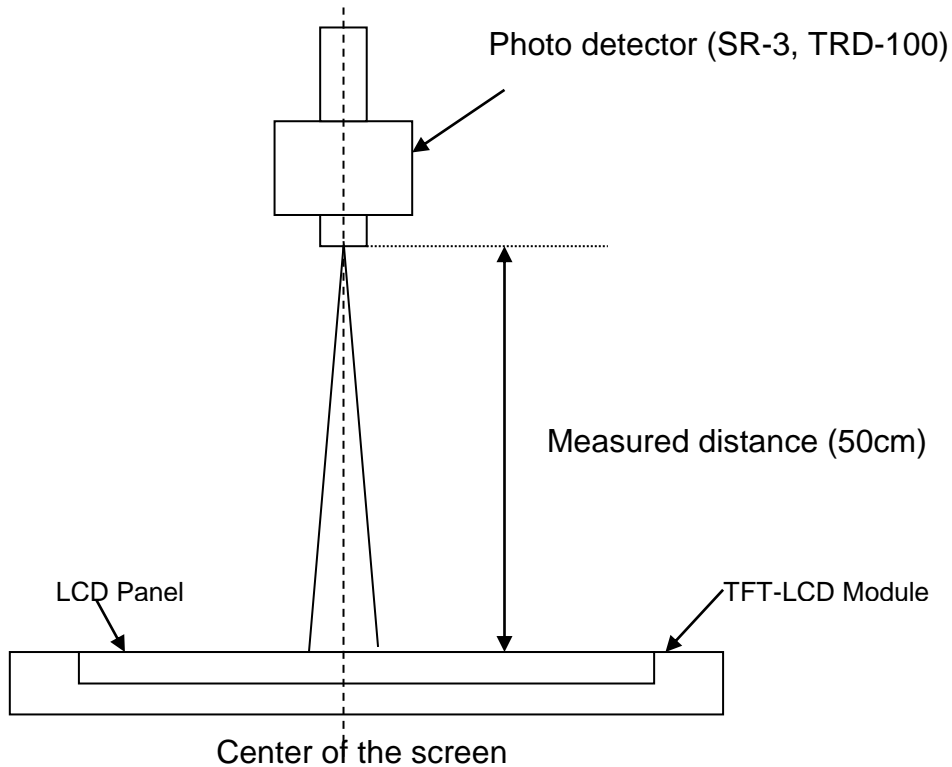

Note 2-3: Luminance Uniformity Measurement

AUO-General Definition:

$$\text{Luminance Uniformity} = \frac{\text{Minimum Luminance of 9 Points (P1 ~ P9)}}{\text{Maximum Luminance of 9 Points (P1 ~ P9)}}$$

a. Test pattern: White Pattern

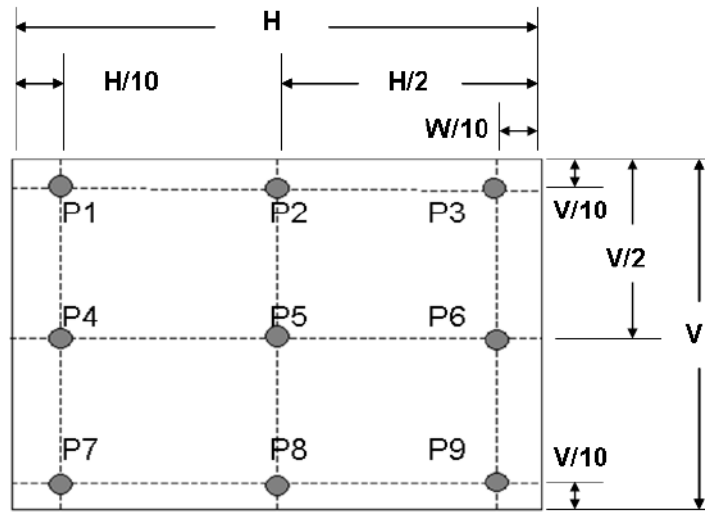

Note 2-4: Contrast Ratio Measurement

Definition:

$$\text{Contrast Ratio} = \frac{\text{Luminance of White pattern}}{\text{Luminance of Black pattern}}$$

- a. Measured position: Center of screen (P5) & perpendicular to the screen ($\theta = \Phi = 0^\circ$)

Note 2-5: Viewing angle measurement

Definition: The angle at which the contrast ratio is greater than 10 & 5 .

- a. Horizontal view angle: Divide to left & right (θ_L & θ_R)
Vertical view angle: Divide to up & down (Φ_H & Φ_L)

AUO-General

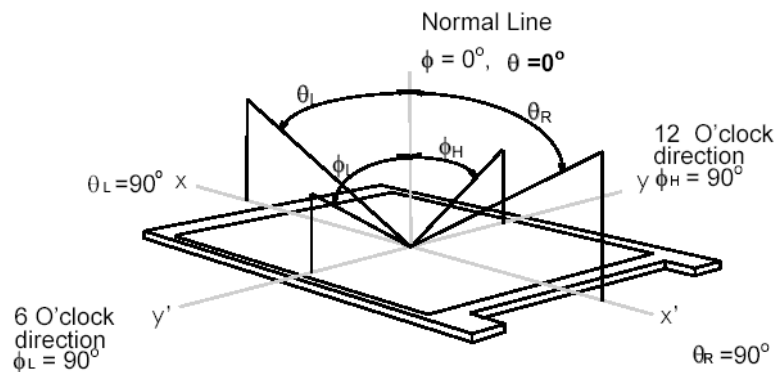

Note 2-6: Response time measurement

The output signals of photo detector are measured when the input signals are changed from “Gray level A” to “Gray level B” (falling time, T_F), and from “Gray level B” to “Gray level A” (rising time, T_R), respectively. The response time is interval between the 10% and 90% of optical response.

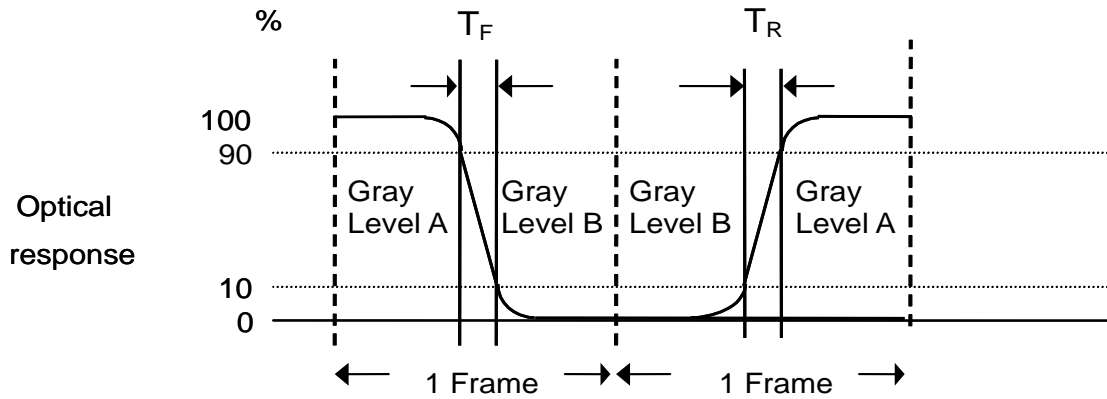

The gray to gray response time is defined as the following table.

Gray Level to Gray Level		Falling Time				
		G0	G63	G127	G191	G255
Rising Time	G0					
	G63					
	G127					
	G191					
	G255					

■ T_{GTG_typ} is the total average time at rising time and falling time of gray to gray.

Note 2-7: Crosstalk measurement

Definition:

$$CT = \text{Max. } (CT_H, CT_V);$$

Where

a. Maximum Horizontal Crosstalk :

$$CT_H = \text{Max. } (| Y_{BL} - Y_{AL} | / Y_{AL} \times 100 \%, | Y_{BR} - Y_{AR} | / Y_{AR} \times 100 \%);$$

Maximum Vertical Crosstalk:

$$CT_V = \text{Max. } (| Y_{BU} - Y_{AU} | / Y_{AU} \times 100 \%, | Y_{BD} - Y_{AD} | / Y_{AD} \times 100 \%);$$

b. $Y_{AU}, Y_{AD}, Y_{AL}, Y_{AR}$ = Luminance of measured location without Black pattern

$Y_{BU}, Y_{BD}, Y_{BL}, Y_{BR}$ = Luminance of measured location with Black pattern

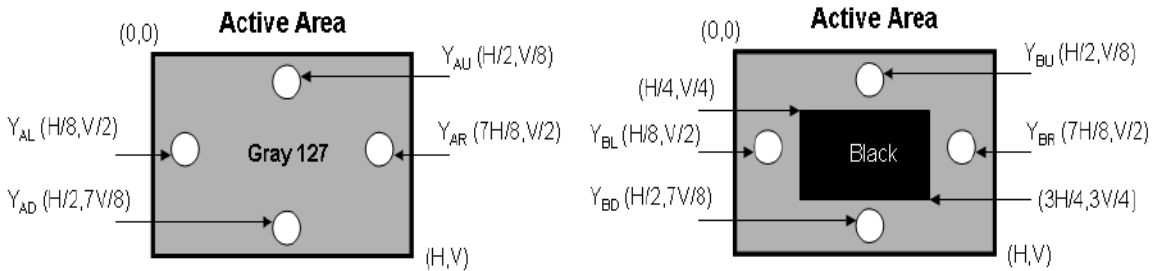

Note 2-8: Flicker measurement

a. Test pattern: It is listed as following.

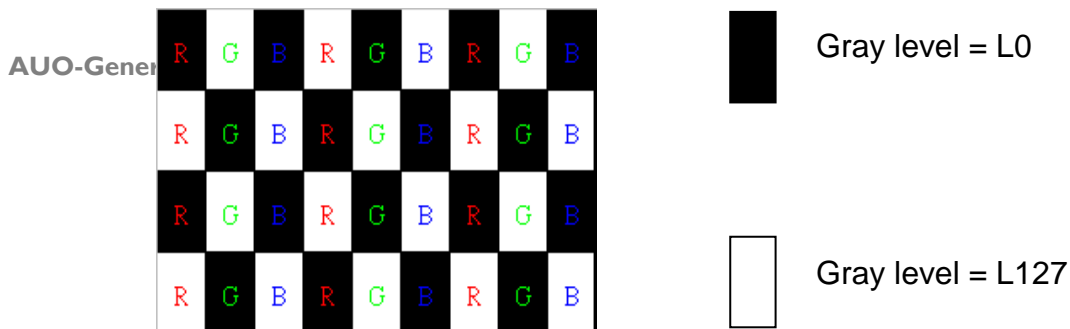

R: Red, G: Green, B:Blue

b. Measured position: Center of screen (P5) & perpendicular to the screen ($\theta = \Phi = 0^\circ$)

3 TFT-LCD Module

3.1 Block Diagram

The following shows the block diagram of the 23.8 inch Color TFT-LCD Module.

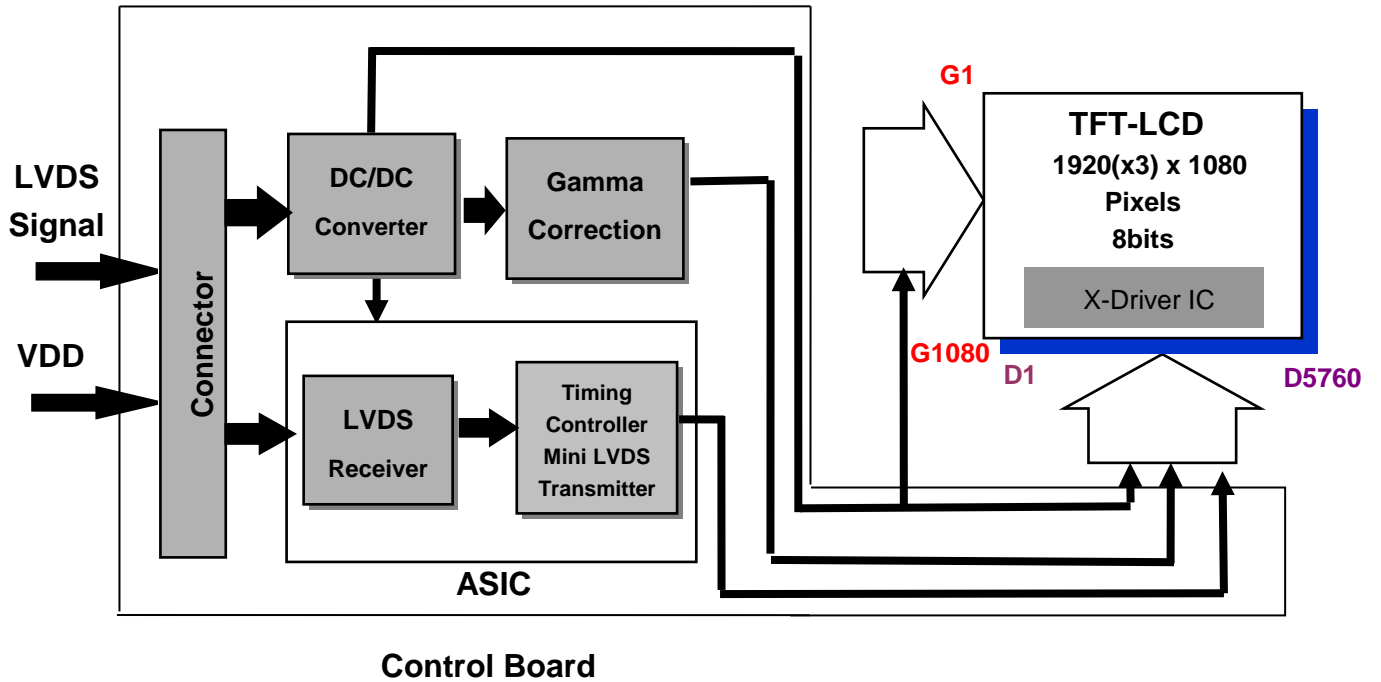

3.2 Interface Connection

3.2.1 Connector Type

TFT-LCD Connector	Manufacturer	P-TWO	STM
	Part Number	187034-3009	MSBKT2407P30HB
Mating Connector	Manufacturer	JAE or Equivalent	
	Part Number	FI-X30HL (Locked Type)	

3.2.2 Connector Pin Assignment

PIN #	Symbol	Description	Remark
1	RxO0-	Negative LVDS differential data input (Odd data)	
2	RxO0+	Positive LVDS differential data input (Odd data)	
3	RxO1-	Negative LVDS differential data input (Odd data)	
4	RxO1+	Positive LVDS differential data input (Odd data)	
5	RxO2-	Negative LVDS differential data input (Odd data)	
6	RxO2+	Positive LVDS differential data input (Odd data)	
7	GND	Ground	
8	RxOCLK-	Negative LVDS differential clock input (Odd clock)	
9	RxOCLK+	Positive LVDS differential clock input (Odd clock)	
10	RxO3-	Negative LVDS differential data input (Odd data)	
11	RxO3+	Positive LVDS differential data input (Odd data)	
12	RxE0-	Negative LVDS differential data input (Even data)	
13	RxE0+	Positive LVDS differential data input (Even data)	
14	GND	Ground	
15	RxE1-	Negative LVDS differential data input (Even data)	
16	RxE1+	Positive LVDS differential data input (Even data)	
17	GND	Ground	
18	RxE2-	Negative LVDS differential data input (Even data)	
19	RxE2+	Positive LVDS differential data input (Even data)	
20	RxECLK-	Negative LVDS differential clock input (Even clock)	
21	RxECLK+	Positive LVDS differential clock input (Even clock)	
22	RxE3-	Negative LVDS differential data input (Even data)	
23	RxE3+	Positive LVDS differential data input (Even data)	
24	GND	Must Connect to GND	
25	NC	No connection (for AUO test only. Do not connect)	
26	NC	No connection (for AUO test only. Do not connect)	

27	NC	No connection (for AUO test only. Do not connect)	
28	VDD	Power Supply Input Voltage	
29	VDD	Power Supply Input Voltage	
30	VDD	Power Supply Input Voltage	

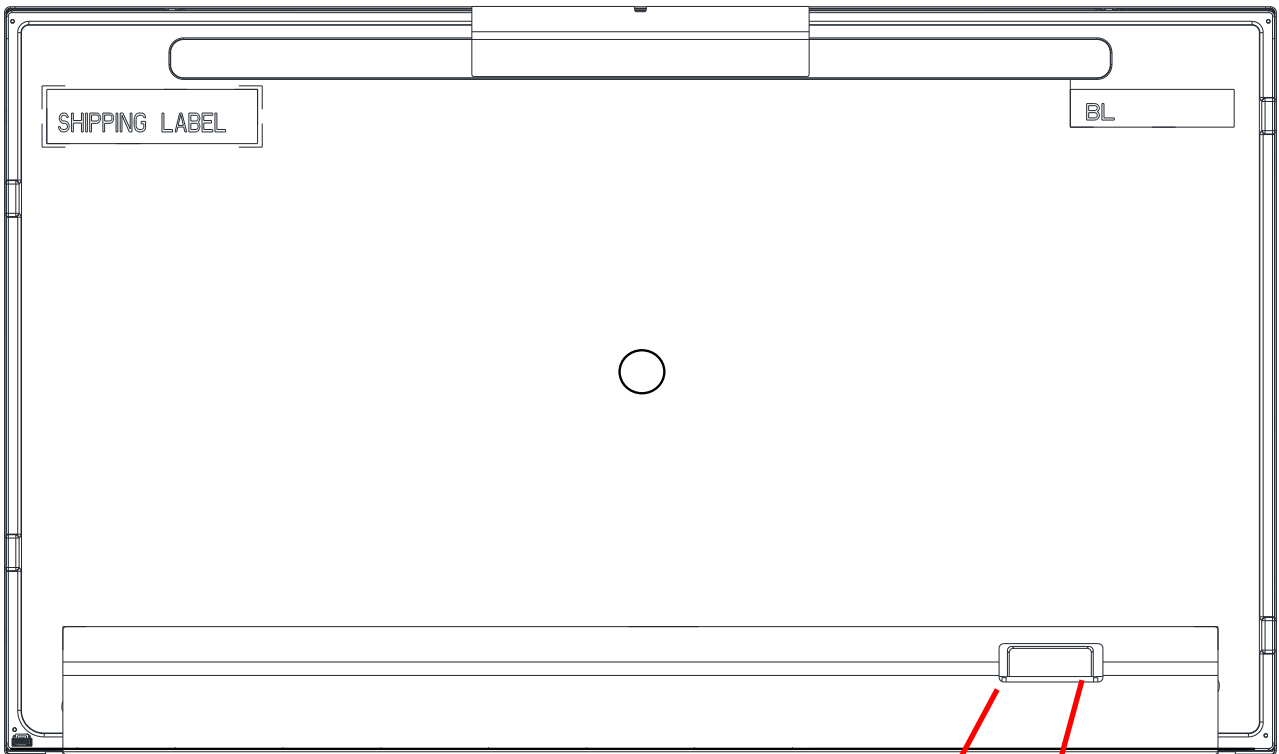

AUO-General

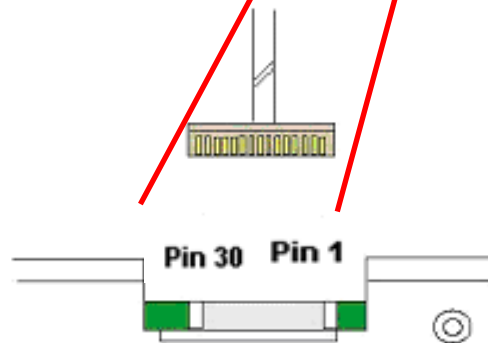

3.3 Electrical Characteristics

3.3.1 Absolute Maximum Rating

Permanent damage may occur if exceeding the following maximum rating.

Symbol	Description	Min	Max	Unit	Remark
VDD	Power Supply Input Voltage	GND-0.3	6.0	[Volt]	Ta=25°C

3.3.2 Recommended Operating Condition

Symbol	Description	Min	Typ	Max	Unit	Remark
VDD	Power supply Input voltage	4.5	5.0	5.5	[Volt]	
IDD	Power supply Input Current (RMS)	-	0.92	1.10	[A]	VDD= 5.0V, White Pattern, Fv=60Hz
		-	1.05	1.26	[A]	VDD= 5.0V, White Pattern, Fv=75Hz
PDD	VDD Power Consumption	-	4.6	5.5	[Watt]	VDD= 5.0V, White Pattern, Fv=60Hz
		-	5.25	6.3	[Watt]	VDD= 5.0V, White Pattern, Fv=75Hz
IRush	Inrush Current	-	-	3.0	[A]	Note 3-1
VDDrp	Allowable VDD Ripple Voltage	-	-	500	[mV]	VDD= 5.0V, Black Pattern, Fv=75Hz

Note 3-1: Inrush Current measurement:

Test circuit:

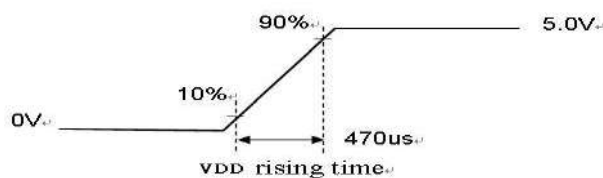
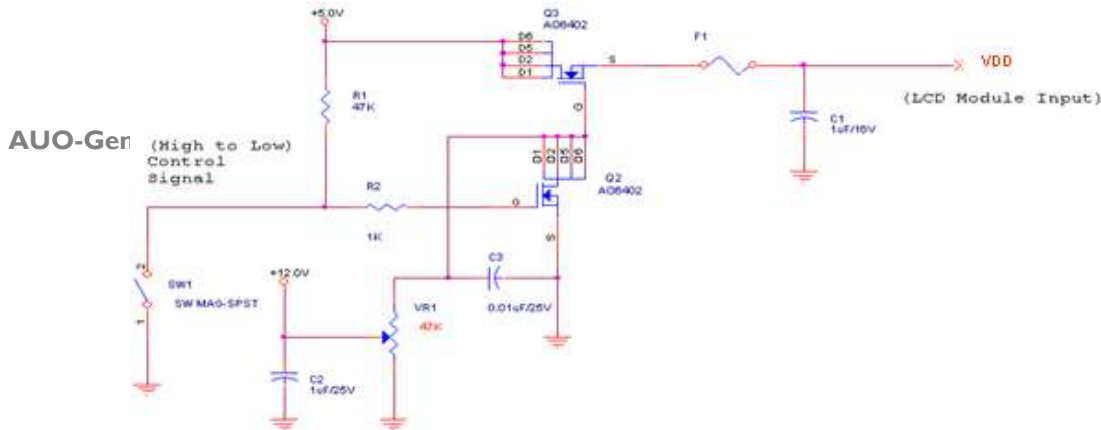

The duration of VDD rising time: 470us.

3.4 Signal Characteristics

3.4.1 LCD Pixel Format

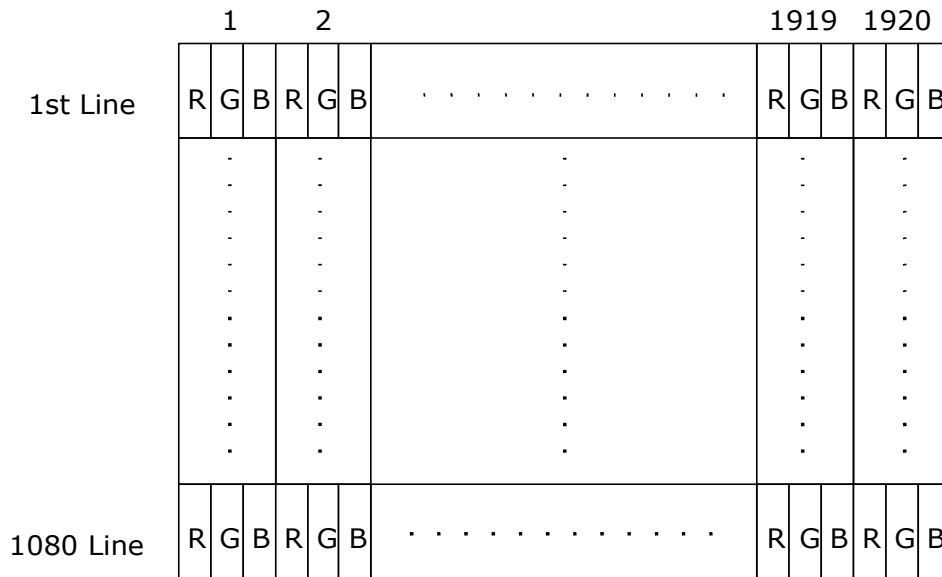

3.4.2 LVDS Data Format

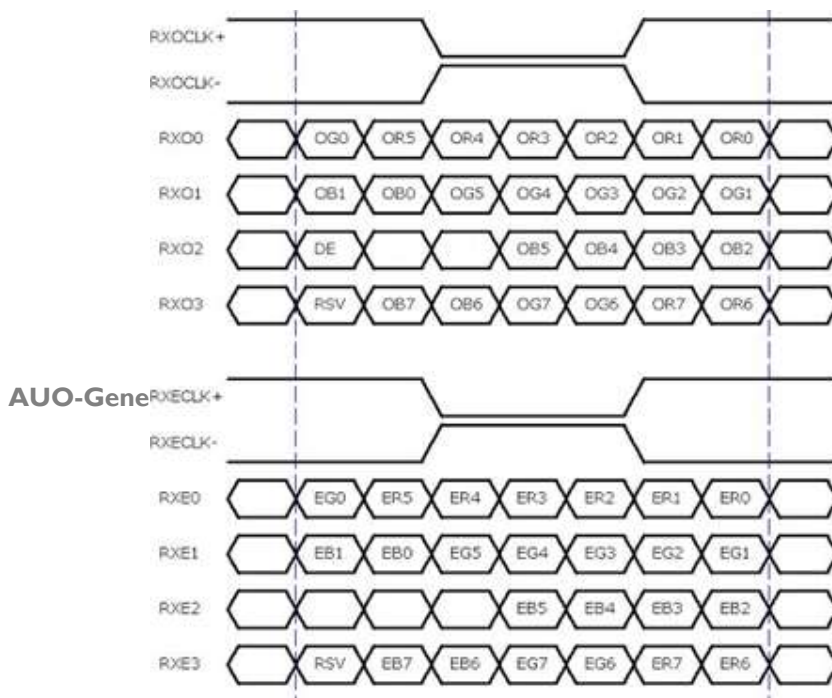

8 Bit Color Bit Order			
MSB	R7	G7	B7
	R6	G6	B6
	R5	G5	B5
	R4	G4	B4
	R3	G3	B3
	R2	G2	B2
	R1	G1	B1
LSB	R0	G0	B0

Note 3-2:

- a. O = "Odd Pixel Data" E = "Even Pixel Data"
- b. Refer to 3.4.1 LCD pixel format, the 1st data is 1 (Odd Pixel Data), the 2nd data is 2 (Even Pixel Data) and the last data is 1920 (Even Pixel Data).

3.4.3 Color versus Input Data

The following table is for color versus input data (8bit). The higher the gray level, the brighter the color.

Color	Gray Level	Color Input Data																								Remark
		RED data (MSB:R7, LSB:R0)								GREEN data (MSB:G7, LSB:G0)								BLUE data (MSB:B7, LSB:B0)								
		R7	R6	R5	R4	R3	R2	R1	R0	G7	G6	G5	G4	G3	G2	G1	G0	B7	B6	B5	B4	B3	B2	B1	B0	
Black	-	0	0	0	0	0	0	0	0	0	0	0	0	0	0	0	0	0	0	0	0	0	0	0	0	
White	-	1	1	1	1	1	1	1	1	1	1	1	1	1	1	1	1	1	1	1	1	1	1	1	1	
Gray 127	-	0	1	1	1	1	1	1	1	0	1	1	1	1	1	1	1	0	1	1	1	1	1	1	1	
Red	L0	0	0	0	0	0	0	0	0	0	0	0	0	0	0	0	0	0	0	0	0	0	0	0	0	Black
	:	:	:	:	:	:	:	:	:	:	:	:	:	:	:	:	:	:	:	:	:	:	:	:	:	
	L255	1	1	1	1	1	1	1	1	0	0	0	0	0	0	0	0	0	0	0	0	0	0	0	0	
Green	L0	0	0	0	0	0	0	0	0	0	0	0	0	0	0	0	0	0	0	0	0	0	0	0	0	Black
	:	:	:	:	:	:	:	:	:	:	:	:	:	:	:	:	:	:	:	:	:	:	:	:	:	
	L255	0	0	0	0	0	0	0	0	1	1	1	1	1	1	1	1	0	0	0	0	0	0	0	0	
Blue	L0	0	0	0	0	0	0	0	0	0	0	0	0	0	0	0	0	0	0	0	0	0	0	0	0	Black
	:	:	:	:	:	:	:	:	:	:	:	:	:	:	:	:	:	:	:	:	:	:	:	:	:	
	L255	0	0	0	0	0	0	0	0	0	0	0	0	0	0	0	0	1	1	1	1	1	1	1	1	

3.4.4 LVDS Specification

a. DC Characteristics:

Symbol	Description	Min	Typ	Max	Units	Condition
V_{TH}	LVDS Differential Input High Threshold	-	-	+100	[mV]	$V_{CM} = 1.2V$
V_{TL}	LVDS Differential Input Low Threshold	-100	-	-	[mV]	$V_{CM} = 1.2V$
$ V_{ID} $	LVDS Differential Input Voltage	100	-	600	[mV]	
V_{CM}	LVDS Common Mode Voltage	+1.0	+1.2	+1.5	[V]	$V_{TH} - V_{TL} = 200mV$

LVDS Signal Waveform:

Use RxOCLK- & RxOCLK+ as example.

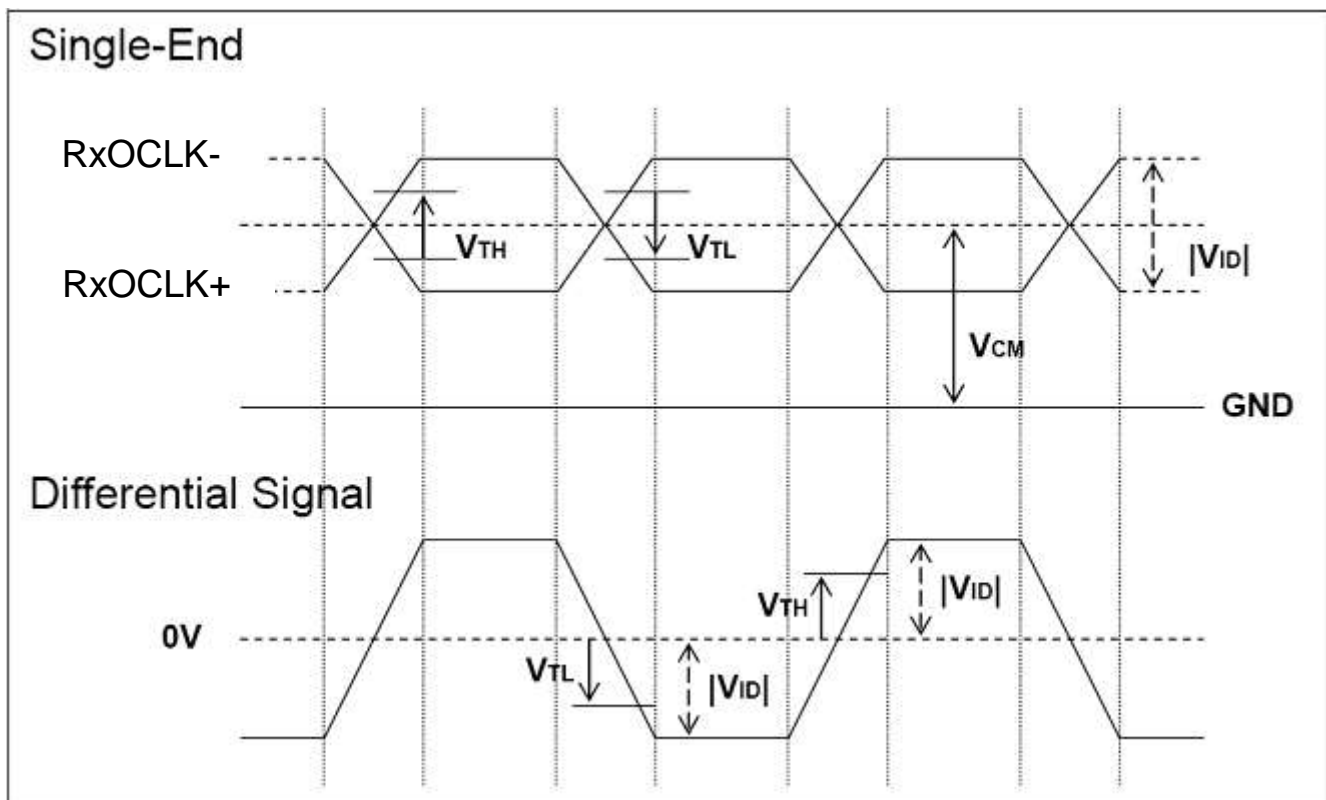

b. AC Characteristics:

Symbol	Description	Min	Max	Unit	Remark
F_{DEV}	Maximum deviation of input clock frequency during Spread Spectrum	-	± 3	%	
F_{MOD}	Maximum modulation frequency of input clock during Spread Spectrum	-	200	KHz	

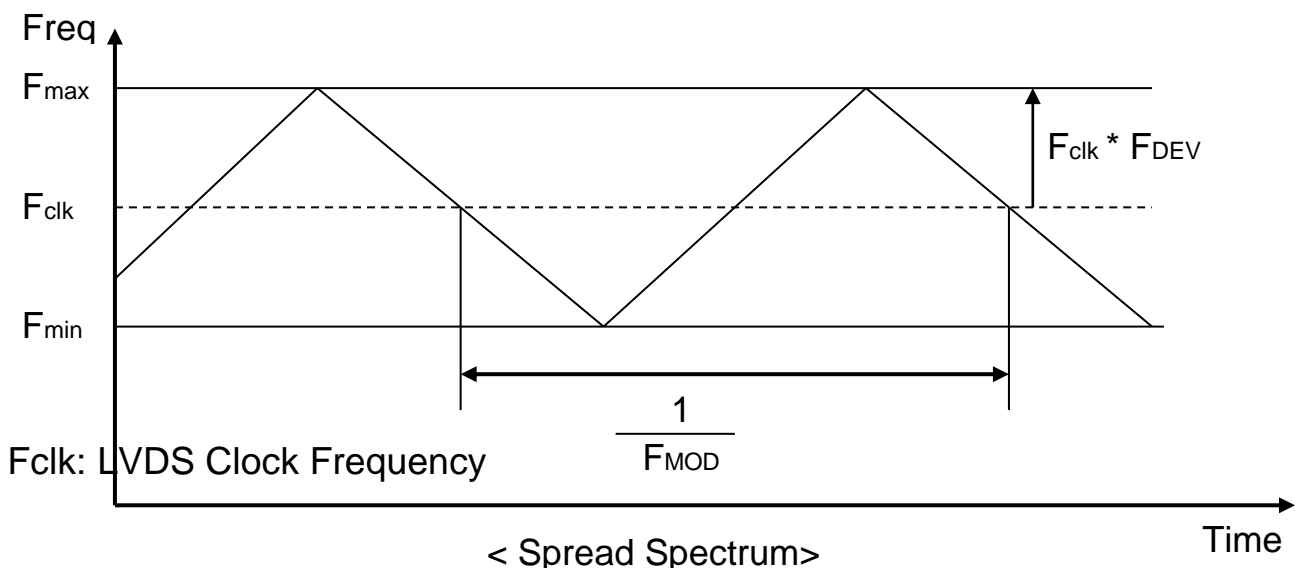

3.4.5 Input Timing Specification

It only support DE mode, and the input timing are shown as the following table.

Symbol	Description		Min.	Typ.	Max.	Unit	Remark
Tv	Vertical Section	Period	1092	1130	1793	Th	
Tdisp (v)		Active	1080	1080	1080	Th	
Tblk (v)		Blanking	12	50	713	Th	
Fv		Frequency	49	60	76	Hz	
Th	Horizontal Section	Period	1004	1050	1100	Tclk	
Tdisp (h)		Active	960	960	960	Tclk	
Tblk (h)		Blanking	44	90	140	Tclk	
Fh		Frequency	54	68	90	KHz	Note 3-3
Tclk	LVDS Clock	Period	11.1	14.0	18.2	ns	1/Fclk
Fclk		Frequency	53.7	71.2	90.0	MHz	Note 3-4

Note 3-3: The equation is listed as following. Please don't exceed the above recommended value.

$$Fh \text{ (Min.)} = Fclk \text{ (Min.)} / Th \text{ (Min.)};$$

$$Fh \text{ (Typ.)} = Fclk \text{ (Typ.)} / Th \text{ (Typ.)};$$

$$Fh \text{ (Max.)} = Fclk \text{ (Max.)} / Th \text{ (Min.)};$$

Note 3-4: The equation is listed as following. Please don't exceed the above recommended value.

$$Fclk \text{ (Min.)} = Fv \text{ (Min.)} \times Th \text{ (Min.)} \times Tv \text{ (Min.)};$$

$$Fclk \text{ (Typ.)} = Fv \text{ (Typ.)} \times Th \text{ (Typ.)} \times Tv \text{ (Typ.)};$$

$$Fclk \text{ (Max.)} = Fv \text{ (Max.)} \times Th \text{ (Typ.)} \times Tv \text{ (Typ.)};$$

3.4.6 Input Timing Diagram

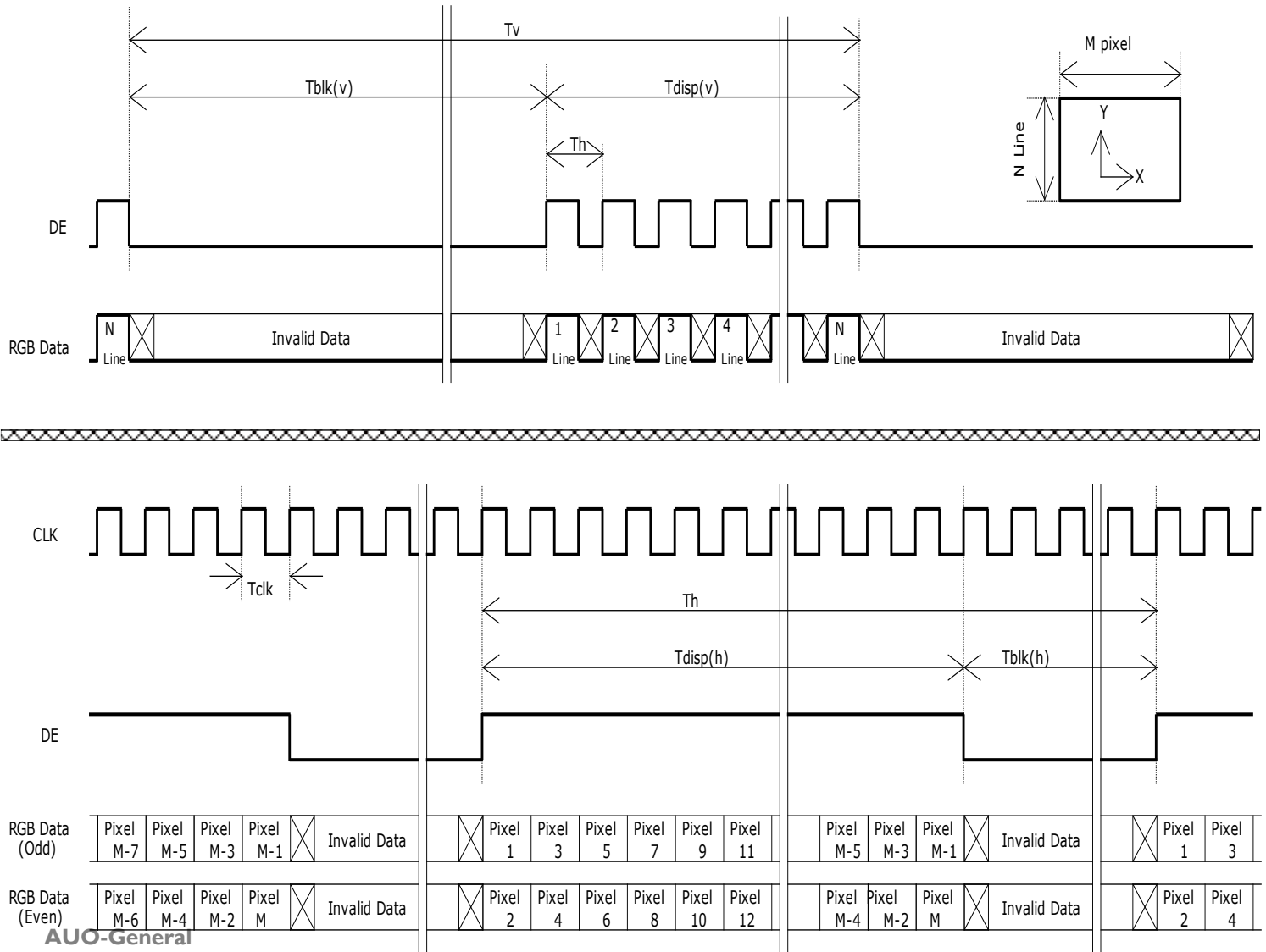

3.5 Power ON/OFF Sequence

VDD power, LVDS signal and backlight on/off sequence are as following. LVDS signals from any system shall be Hi-Z state when VDD is off.

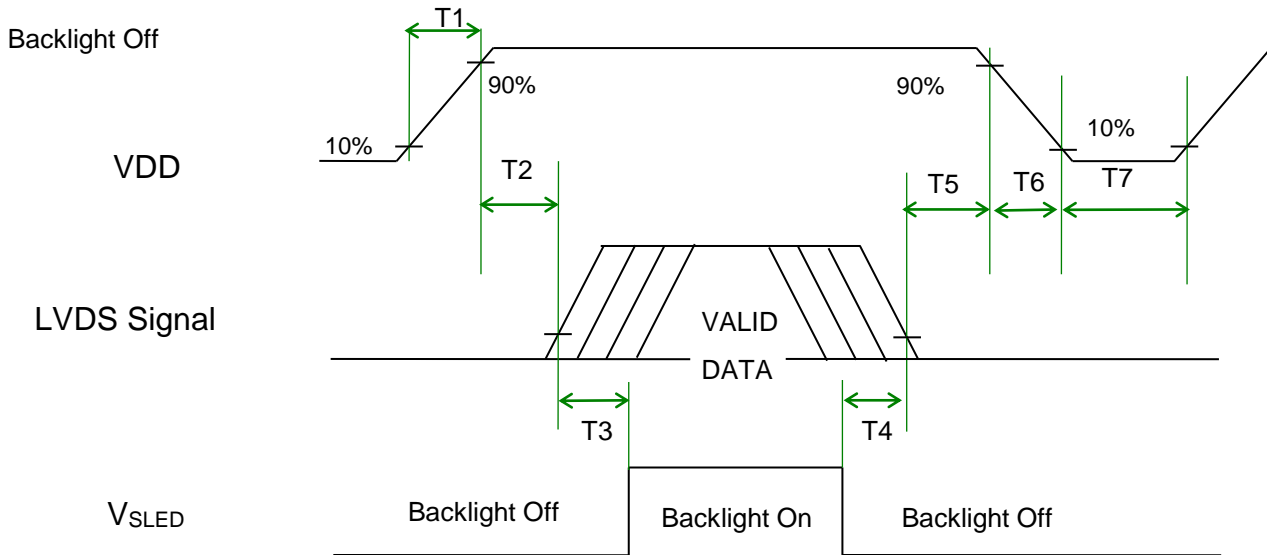

Power Sequence Timing

Symbol	Value			Unit	Remark
	Min.	Typ.	Max.		
T1	0.5	-	10	[ms]	
T2	0	-	50	[ms]	
T3	500	-	-	[ms]	
T4	100	-	-	[ms]	
T5	0	-	50	[ms]	Note 3-5 Note 3-6
T6	0	-	150	[ms]	Note 3-6
T7	1000	-	-	[ms]	

Note 3-5 : Recommend setting T5 = 0ms to avoid electronic noise when VDD is off.

Note 3-6 : During T5 and T6 period , please keep the level of input LVDS signals with Hi-Z state.

4 Backlight Unit

4.1 Block Diagram

The following shows the block diagram of the 23.8 inch Backlight Unit. And it includes 72 pcs LED in the LED light bar. (4 strings and 18 pcs LED of one string).

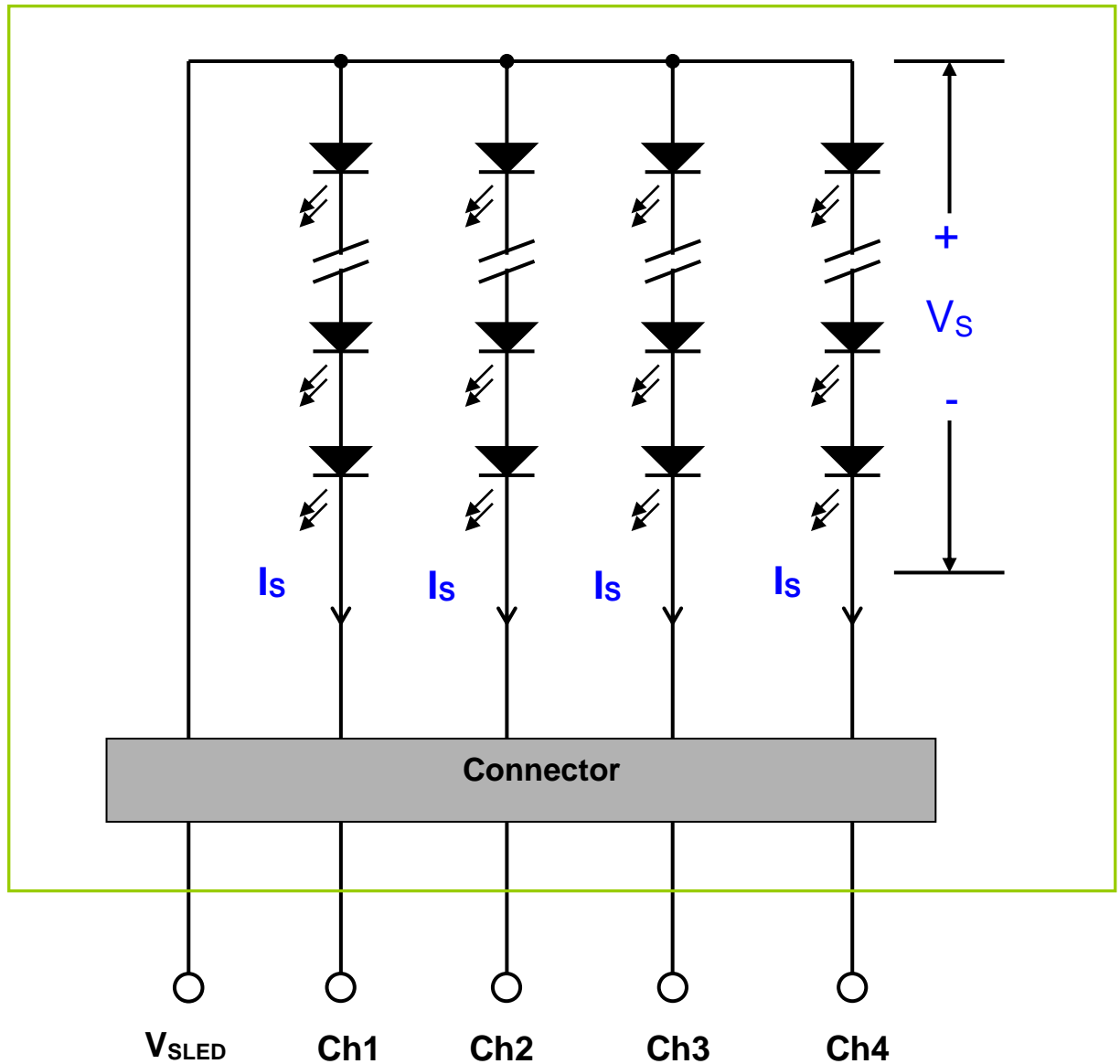

AUO-General

4.2 Interface Connection

4.2.1 Connector Type

Backlight Connector	Manufacturer	ENTERY
	Part Number	3707K-S06N-21R (BLACK) (Locking Type, Wire Harness)
Mating Connector	Manufacturer	ENTERY or Equivalent
	Part Number	H112K-P06N-00B (Non-Locking type) H112K-P06N-03B (Locking type)

Backlight Connector dimension:

$H \times V \times D = 7.9 \times 3.05 \times 4.25$, Pitch=1.0(unit=mm)

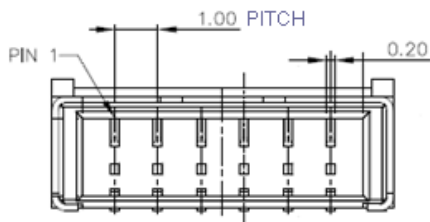
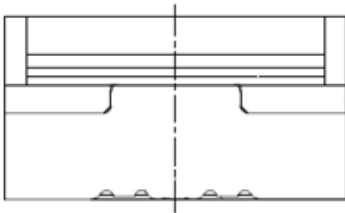

Mating Connector dimension:

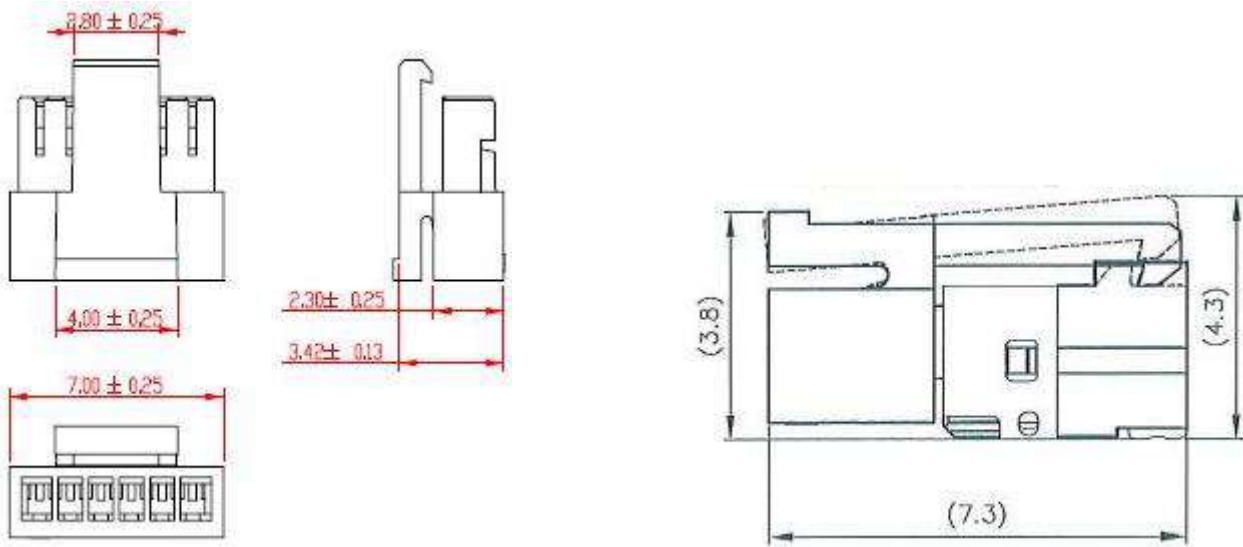

AUO-General

4.2.2 Connector Pin Assignment

Pin#	Symbol	Description	Remark
1	Ch1	LED Current Feedback Terminal (Channel 1)	
2	Ch2	LED Current Feedback Terminal (Channel 2)	
3	V _{SLED}	LED Power Supply Voltage Input Terminal	
4	V _{SLED}	LED Power Supply Voltage Input Terminal	
5	Ch3	LED Current Feedback Terminal (Channel 3)	
6	Ch4	LED Current Feedback Terminal (Channel 4)	

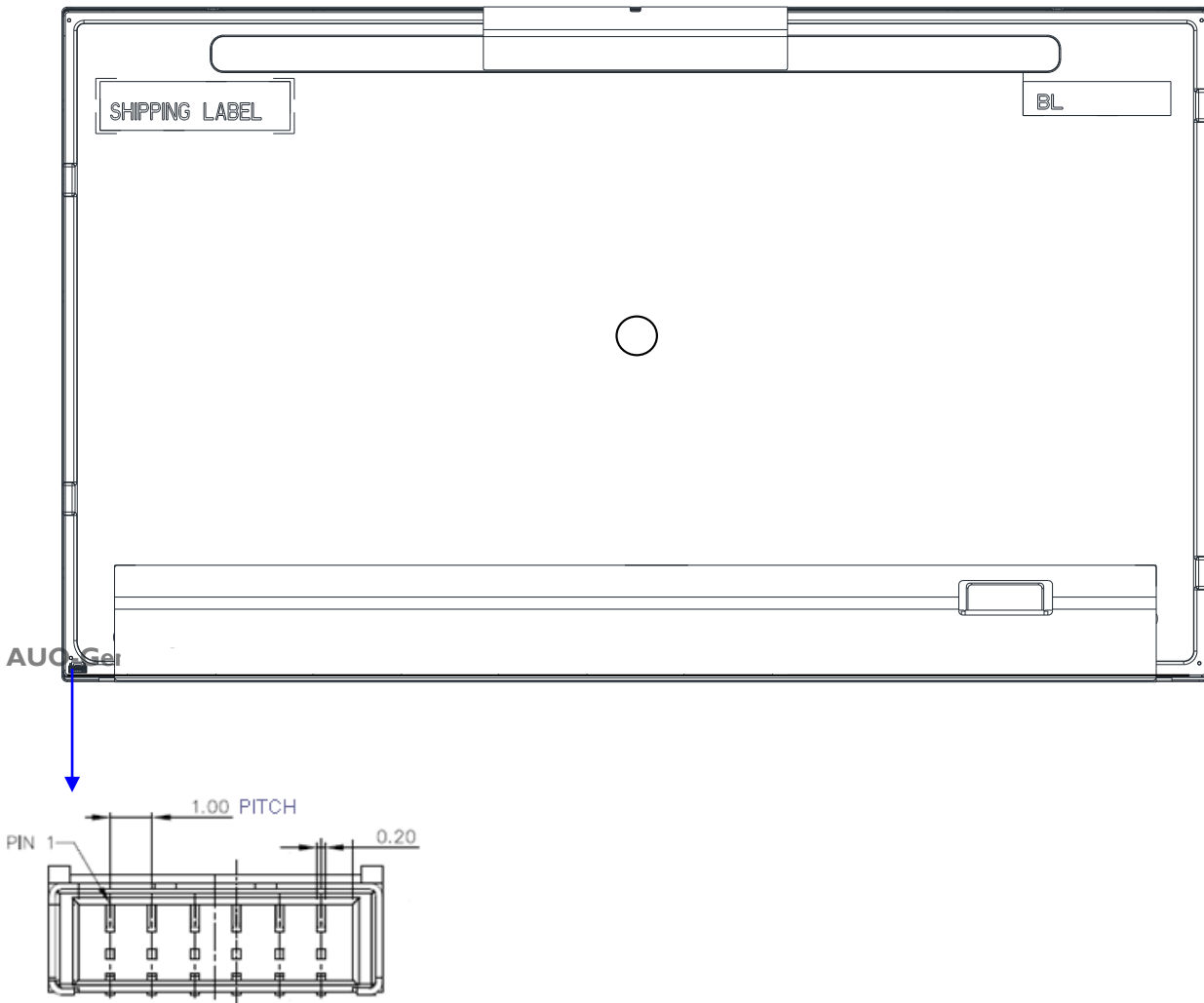

4.3 Electrical Characteristics

4.3.1 Absolute Maximum Rating

Permanent damage may occur if exceeding the following maximum rating.

(Ta=25°C)

Symbol	Description	Min	Max	Unit	Remark
Is	Single LED Current	0	90	[mA]	100% duty ratio
			150	[mA]	Duty ratio ≤ 10% Pulse time=10 ms

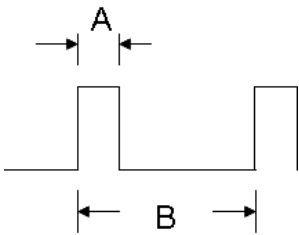

Duty ratio= (A / B) X 100% ; (A: Pulse time, B: Period)

4.3.2 Recommended Operating Condition

(Ta=25°C)

Symbol	Description	Min.	Typ.	Max.	Unit	Remark
Is	LED String Current	-	70	77	[mA]	100% duty ratio of LED chip
Vs	LED String Voltage	48.6	57.6	64.8	[Volt]	Is=70mA @ 100% duty ratio; Note 4-1, Note 4-5
ΔVs	Maximum Vs Voltage Deviation of light bar	-	3.2	3.6	[Volt]	Is=70mA @ 100% duty ratio; Note 4-2
P _{BLU}	LED Light Bar Power Consumption	-	16.1	18.1	[Watt]	Note 4-3
LT _{LED}	LED Life Time	50,000	-	-	[Hour]	Note 4-4
OVP	Over Voltage Protection in system board	110% Vs (max)	-	-	[Volt]	Note 4-5

Note 4-1: $V_s (\text{Typ.}) = V_F (\text{Typ.}) \times \text{LED No. (one string)}$;

- a. V_F : LED chip forward voltage, $V_F (\text{Min.})=2.7$, $V_F(\text{Typ.})=3.2\text{V}$, $V_F(\text{Max.})=3.6\text{V}$
- b. The same equation to calculate $V_s(\text{Min.})$ & $V_s (\text{Max.})$ for respective $V_F (\text{Min.})$ & $V_F(\text{Max.})$;

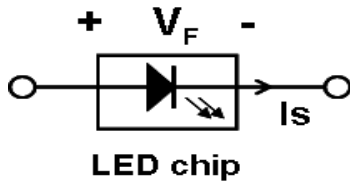

Note 4-2: $\Delta V_s (\text{Max.}) = \Delta V_F \times \text{LED No. (one string)}$;

- a. ΔV_F : LED chip forward voltage deviation; (0.2 V , each Bin of LED V_F)

Note 4-3: $P_{\text{BLU}} (\text{Typ.}) = V_s (\text{Typ.}) \times I_s (\text{Typ.}) \times 4$; (4 is total String No. of LED Light bar)

$P_{\text{BLU}} (\text{Max.}) = V_s (\text{Max.}) \times I_s (\text{Typ.}) \times 4$;

Note 4-4: Definition of life time:

- a. Brightness of LED becomes to 50% of its original value
- b. Test condition: $I_s = 70\text{mA}$ and 25°C (Room Temperature)

Note 4-5: Recommendation for LED driver power design:

Due to there are electrical property deviation in LED & monitor set system component after long time operation. AUO strongly recommend the design value of LED driver board OVP (over voltage protection) should be 10% higher than max. value of LED string voltage (V_s) at least.

Note 4-6: AUO strongly recommend “Analog Dimming” method for backlight brightness control for Wavy Noise Free. Otherwise, recommend that Dimming Control Signal

(PWM Signal) should be synchronized with Frame Frequency.

5 Reliability Test

AUO reliability test items are listed as following table. (*Bare Panel only*)

Items	Condition	Remark
Temperature Humidity Bias (THB)	Ta= 50°C, 80%RH, 300hours	
High Temperature Operation (HTO)	Ta= 50°C, 300hours	
Low Temperature Operation (LTO)	Ta= 0°C, 300hours	
High Temperature Storage (HTS)	Ta= 60°C, 300hours	
Low Temperature Storage (LTS)	Ta= -20°C, 300hours	
Vibration Test (Non-operation)	Acceleration: 1.5 Grms Wave: Random Frequency: 10 - 200 Hz Sweep: 30 Minutes each Axis (X, Y, Z)	
Shock Test (Non-operation)	Acceleration: 50 G Wave: Half-sine Active Time: 20 ms Direction: ±X, ±Y, ±Z (one time for each Axis)	
Thermal Shock Test (TST)	-20°C/30min, 60°C/30min, 100 cycles	Note 1
On/Off Test	On/10sec, Off/10sec, 30,000 cycles	
ESD (Electro Static Discharge)	Contact Discharge: ± 8KV, 150pF(330Ω) 1sec, 8 points, 25 times/ point.	Note 2
	Air Discharge: ± 15KV, 150pF(330Ω) 1sec 8 points, 25 times/ point.	
Altitude Test	Operation:18,000 ft Non-Operation:40,000 ft	

Note 1: A cycle of rapid temperature change consists of varying the temperature from -20°C to 60°C, and back again. Power is not applied during the test. After finish temperature cycling, the unit is placed in normal room ambient for at least 4 hours before power on.

Note 2: According to EN61000-4-2, ESD class B: Some performance degradation allowed. No data lost Self-recoverable. No hardware failures.

Note3:

- Water condensation is not allowed for each test items.
- Each test is done by new TFT-LCD module. Don't use the same TFT-LCD module repeatedly for reliability test.
- The reliability test is performed only to examine the TFT-LCD module capability.
- To inspect TFT-LCD module after reliability test, please store it at room temperature and room humidity for 24 hours at least in advance.
- No function failure occurs.

6 Shipping Label

The label is on the panel as shown below:

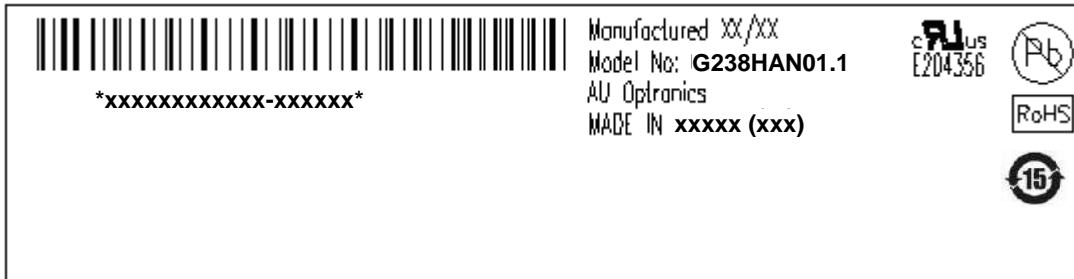

Note 6-1: For Pb Free products, AUO will add  for identification.

Note 6-2: For RoHS compatible products, AUO will add  for identification.

Note 6-3: For China RoHS compatible products, AUO will add  for identification.

Note 6-4: The Green Mark will be presented only when the green documents have been ready by AUO Internal Green Team.

8 Packing Specification

8.1 Packing Flow

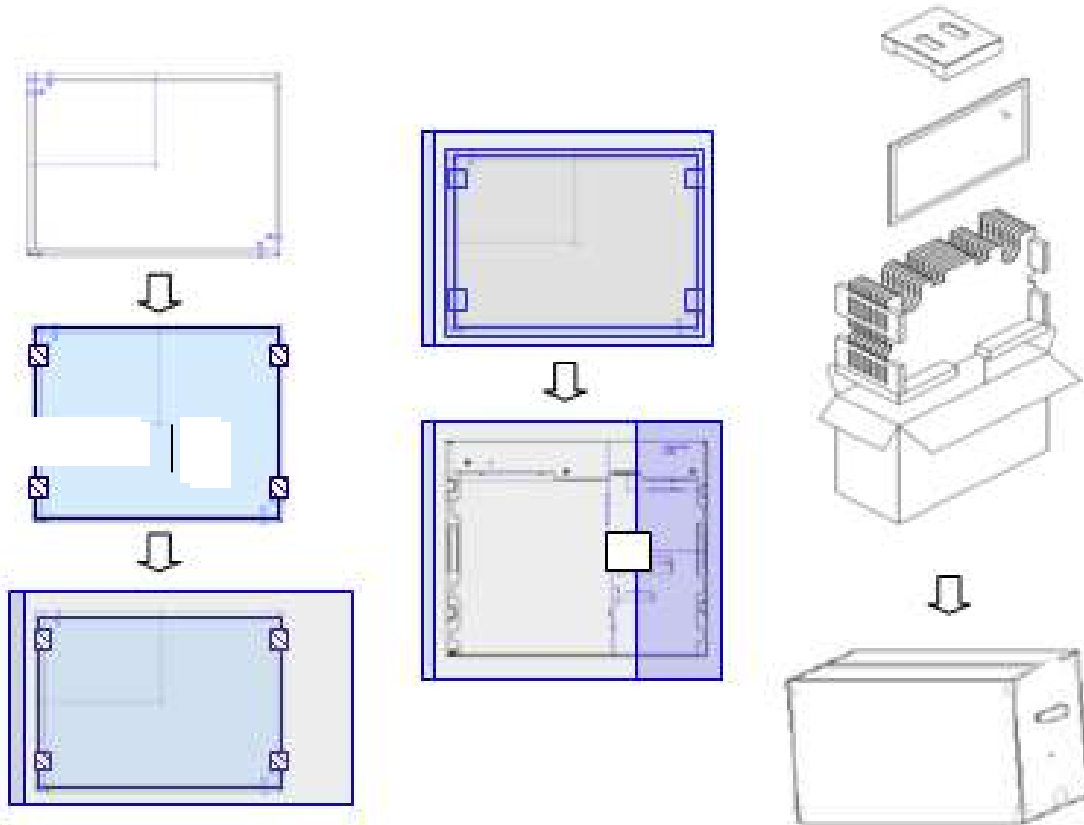

AUO-General

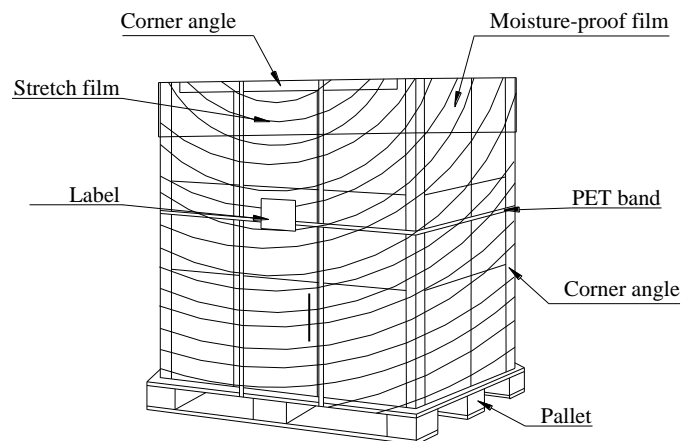

8.2 Pallet and shipment information

Item	Specification			Remark
	Q'ty	Dimension	Weight(kg)	
Panel	1	543.0(H) x 317.4(V) x 11.2(D) (Typ.)	2.300	
Cushion	1	-	1.7	
Box	1	610mmx 270mmx 430 mm	1.3	without Panel & cushion
Packing Box	7 pcs/Box	610mmx 270mmx 430 mm	19	with panel & cushion
Pallet	1	1150 mm * 840mm * 132 mm	12	
Pallet after Packing	12 boxes/pallet	1150(L)mm x 840(W)mm x 1440(H)mm	240	