

### Brief Description

The ZLED7x30 continuous-mode inductive step-down converter family is one of our ZLED LED-control ICs. It is designed for applications requiring high brightness and high current. The ZLED7x30 can efficiently drive a single LED or multiple series-connected LEDs from a voltage input higher than the LED forward voltage ( $V_{in} = 8.5$  to 40VDC). It provides an adjustable output current (1.2A maximum), which is set via an external resistor and controlled by the ZLED7x30's integrated high-side output current-sensing circuit and high speed internal 40V power switch. Its low conducting impedance ensures high system efficiency.

The ZLED7x30 provides a switch dimming function. It detects external switch action to adjust output current, allowing dimming functionality to be achieved without changing the original lighting system circuitry.

The switch dimming is implemented in either two-level mode or three-level mode. The output current of every level and the total number of levels are customer selected by setting the corresponding input conditions of DIM1 and DIM2 pin.

The ZLED7x30 enables diverse industrial and consumer lighting applications requiring high driving currents, wide operating voltage range, high efficiency, and variable brightness control. It offers over-temperature and LED open-circuit protection. The ZLED7x30 can also minimize bill-of-material costs because very few external components are required for most applications. Only a resistor, a diode, an inductor, and three capacitors are needed for a typical basic application.

### Features

- Switch dimming with multiple levels
- Three modes for output level settings
- Up to 1.2A output current
- Internal 40V power switch
- Wide DC input voltage range 8.5 to 40 VDC
- Output current accuracy: 5% (typical)
- LED open-circuit protection
- Thermal shutdown protection

### Benefits

- High efficiency: up to 98%
- Very few external components needed for operation
- Adds switch dimming function to existing installation

### Available Support

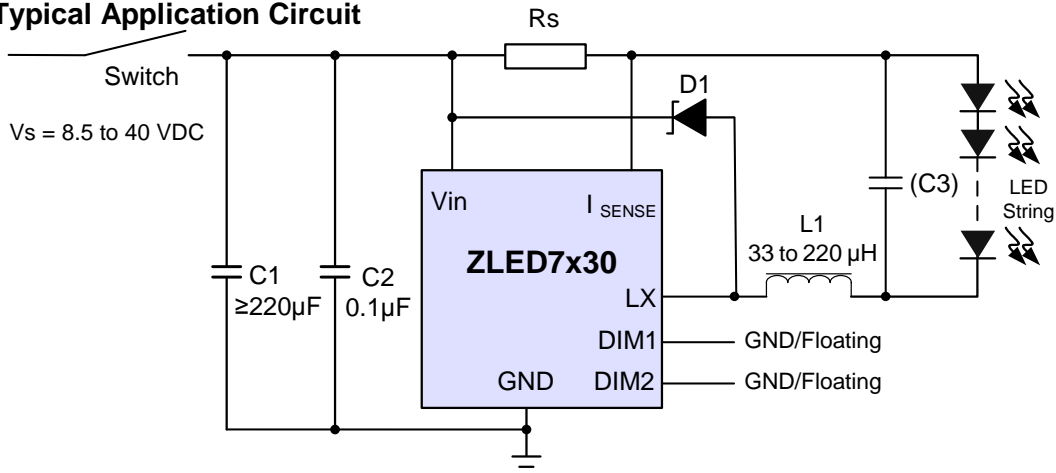
- Evaluation Kit

### Physical Characteristics

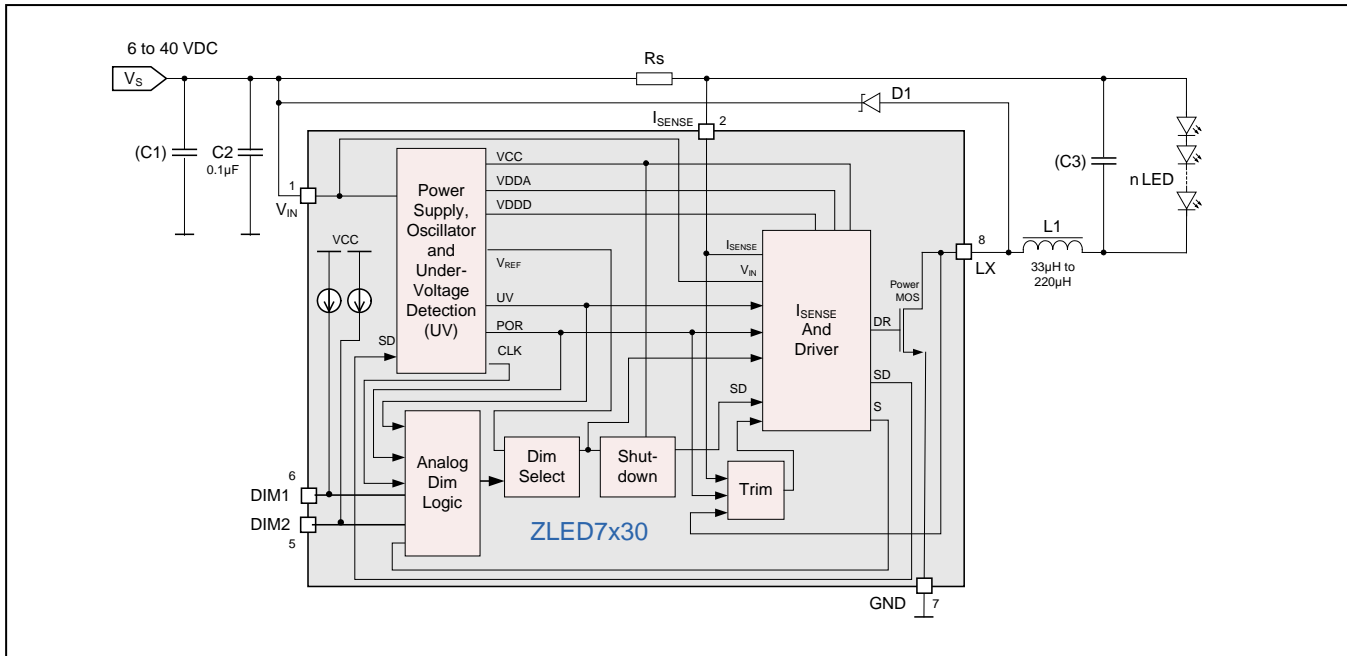
- Operating temperature: -40°C to 105°C
- Switching frequency: up to 1MHz
- SOP-8 package

ZLED7x30 Family Selection Matrix		
Product	Max. Current Output	Package
ZLED7030	1.2A	SOP-8
ZLED7330	1.0A	SOP-8
ZLED7530	0.75A	SOP-8
ZLED7730	0.35A	SOP-8

### ZLED7x30 Typical Application Circuit



## ZLED7x30 Block Diagram



### Typical Applications

- ❖ Illuminated LED signs and other displays
- ❖ LED street and traffic lighting (low voltage)
- ❖ Architecture/building LED lighting
- ❖ LED backlighting
- ❖ Interior/exterior LED lighting
- ❖ MR16 LED spot lights
- ❖ Retrofit LED lighting fixtures
- ❖ General purpose industrial and consumer LED applications

## Ordering Information

Product Sales Code	Description	Package
ZLED7030ZI1R	ZLED7030 – High Current (1200mA) 40V LED Driver with Switch Dimming	SOP-8 (Tape & Reel)
ZLED7330ZI1R	ZLED7330 – High Current (1000mA) 40V LED Driver with Switch Dimming	SOP-8 (Tape & Reel)
ZLED7530ZI1R	ZLED7530 – High Current (750mA) 40V LED Driver with Switch Dimming	SOP-8 (Tape & Reel)
ZLED7730ZI1R	ZLED7730 – High Current (350mA) 40V LED Driver with Switch Dimming	SOP-8 (Tape & Reel)
ZLED7030KIT-D1	ZLED7030-D1 Demo Board, 1 ZLED-PCB8 and 5 ZLED7030 ICs	Kit
ZLED-PCB8	Test PCB with one 5W white High Brightness (HB) LED, cascadable to one multiple LED string	Printed Circuit Board (PCB)



Corporate Headquarters  
6024 Silver Creek Valley Road  
San Jose, CA 95138  
[www.IDT.com](http://www.IDT.com)

Sales  
1-800-345-7015 or 408-284-8200  
Fax: 408-284-2775  
[www.IDT.com/go/sales](http://www.IDT.com/go/sales)

Tech Support  
[www.IDT.com/go/support](http://www.IDT.com/go/support)

DISCLAIMER Integrated Device Technology, Inc. (IDT) reserves the right to modify the products and/or specifications described herein at any time, without notice, at IDT's sole discretion. Performance specifications and operating parameters of the described products are determined in an independent state and are not guaranteed to perform the same way when installed in customer products. The information contained herein is provided without representation or warranty of any kind, whether express or implied, including, but not limited to, the suitability of IDT's products for any particular purpose, an implied warranty of merchantability, or non-infringement of the intellectual property rights of others. This document is presented only as a guide and does not convey any license under intellectual property rights of IDT or any third parties.

IDT's products are not intended for use in applications involving extreme environmental conditions or in life support systems or similar devices where the failure or malfunction of an IDT product can be reasonably expected to significantly affect the health or safety of users. Anyone using an IDT product in such a manner does so at their own risk, absent an express, written agreement by IDT.

Integrated Device Technology, IDT and the IDT logo are trademarks or registered trademarks of IDT and its subsidiaries in the United States and other countries. Other trademarks used herein are the property of IDT or their respective third party owners. For datasheet type definitions and a glossary of common terms, visit [www.idt.com/go/glossary](http://www.idt.com/go/glossary). All contents of this document are copyright of Integrated Device Technology, Inc. All rights reserved.

## Contents

1	IC Characteristics .....	5
1.1	Absolute Maximum Ratings .....	5
1.2	Operating Conditions .....	5
1.3	Electrical Parameters .....	6
1.4	Typical Operation Graphs .....	7
2	Circuit Description .....	12
2.1	ZLED7x30 Overview .....	12
2.2	Control of Output Current via External Sense Resistor $R_s$ .....	12
2.3	Multi-Mode Switch Dimming.....	12
2.4	ZLED7x30 Protection Features.....	13
2.4.1	Thermal Shut-down Protection .....	13
2.4.2	LED Open-Load Protection.....	13
3	Application Circuit Design.....	14
3.1	Applications.....	14
3.2	Thermal Considerations for Application Design .....	15
3.2.1	Temperature Effects of Load, Layout, and Component Selection.....	15
3.2.2	Temperature Effects of Low Supply Voltage $V_{IN}$ .....	15
3.3	External Component Selection.....	15
3.3.1	Sense Resistor $R_s$ .....	15
3.3.2	Inductor $L_1$ .....	16
3.3.3	Bypass Capacitor $C_1$ .....	17
3.3.4	De-bouncing Capacitor $C_2$ .....	19
3.3.5	Capacitor $C_3$ for Reducing Output Ripple.....	19
3.3.6	Diode $D_1$ .....	19
3.4	Application Circuit Layout Requirements .....	19
4	ESD Protection .....	20
5	Pin Configuration and Package .....	20
6	Ordering Information .....	21
7	Document Revision History .....	22

## List of Figures

Figure 1.1	ZLED7x30 Supply Operating Current vs. Input Supply Voltage ( $V_{IN} = 8.5$ to $40V$ ) .....	7
Figure 1.2	Efficiency (%) vs. Input Supply Voltage ( $V_{IN} = 8.5$ to $40V$ ) Per Number of LEDs ( $R_s=0.10\Omega$ , $L_1=47\mu H$ ).....	7
Figure 1.3	Efficiency vs. Input Supply Voltage ( $V_{IN} = 8.5$ to $40V$ ) Per Number of LEDs ( $R_s=0.15\Omega$ , $L_1=47\mu H$ ) .....	8
Figure 1.4	Efficiency vs. Input Supply Voltage ( $V_{IN} = 8.5$ to $40V$ ) <sup>‡</sup> Per Number of LEDs ( $R_s=0.30\Omega$ , $L_1=47\mu H$ ).....	8
Figure 1.5	Output Current Variation vs. Input Supply Voltage ( $V_{IN} = 8.5$ to $40V$ ) Per Number of LEDs ( $R_s=0.15\Omega$ , $L_1=47\mu H$ ) <sup>9</sup>	9
Figure 1.6	Sense Voltage vs. Operating Temperature ( $R_s=0.10\Omega$ , $L_1=47\mu H$ , $V_{IN} = 40 V$ ) .....	9
Figure 1.7	Switch Dimming Waveform (Dimming Mode 2) .....	10
Figure 1.8	LED Open-Circuit Protection ( $R_s=0.30\Omega$ , $L_1=47\mu H$ , $V_{IN} = 24 V$ ) .....	11
Figure 3.1	ZLED7x30 Application Circuit for Switch Dimming .....	14
Figure 3.2	Basic ZLED7x30 Application Circuit with Output Current Determined only by $R_s$ .....	14
Figure 3.3	ZLED7x30 Application Circuit using a Halogen Electronic Transformer to Operate with AC Line Supply ....	15
Figure 5.1	ZLED7x30 Pin Configuration .....	20

## List of Tables

Table 2.1	Dimming Configuration Options.....	13
Table 3.1	Recommended Values for Sense Resistor $R_s$ .....	16
Table 5.1	ZLED7x30 Pin Descriptions—SOP-8 Package.....	20
Table 5.2	Package Dimensions SOP-8 .....	21

## 1 IC Characteristics

Note: Exceeding the maximum ratings given in this section could cause operation failure and/or cause permanent damage to the ZLED7x30. Exposure to these conditions for extended periods may affect device reliability.

### 1.1 Absolute Maximum Ratings

No.	PARAMETER	SYMBOL	CONDITIONS	MIN	TYP	MAX	UNIT
1.1.1	Input voltage (also see specification 1.2.2)	$V_{IN}$		-0.3		50	V
1.1.2	$I_{SENSE}$ pin voltage	$V_{ISENSE}$	$V_{IN} \geq 5V$	$V_{IN} - 5V$		$V_{IN} + 0.3V$	V
			$V_{IN} < 5V$	-0.3V		$V_{IN} + 0.3V$	V
1.1.3	LX pin output voltage	$V_{LX}$		-0.3		50	V
1.1.4	DIM1, DIM2 pin input voltage	$V_{DIM}$		-0.3		6	V
1.1.5	LX pin switch output current	$I_{LX}$				1.5	A
1.1.6	Power dissipation	$P_{tot}$				0.5	W
1.1.7	ESD performance		Human Body Model	$\pm 3$			kV
1.1.8	Junction temperature	$T_J$				150	°C
1.1.9	Junction to ambient thermal resistance	$R_{\theta JA}$				100	K/W
1.1.10	Storage temperature	$T_S$		-55		150	°C

### 1.2 Operating Conditions

No.	PARAMETER	SYMBOL	CONDITIONS	MIN	TYP	MAX	UNIT
1.2.1	Operating temperature	$T_{amb}$		-40		105	°C
1.2.2	Input voltage (also see specification 1.1.1)	$V_{IN}$		8.5		40	V

### 1.3 Electrical Parameters

Except as noted, test conditions for the following specifications are  $T_{amb} = 25^{\circ}\text{C}$  typical and  $V_{IN} = 12\text{V}$  unless otherwise noted.

Production testing of the chip is performed at  $25^{\circ}\text{C}$  unless otherwise stated. Functional operation of the chip and specified parameters at other temperatures are guaranteed by design, characterization, and process control.

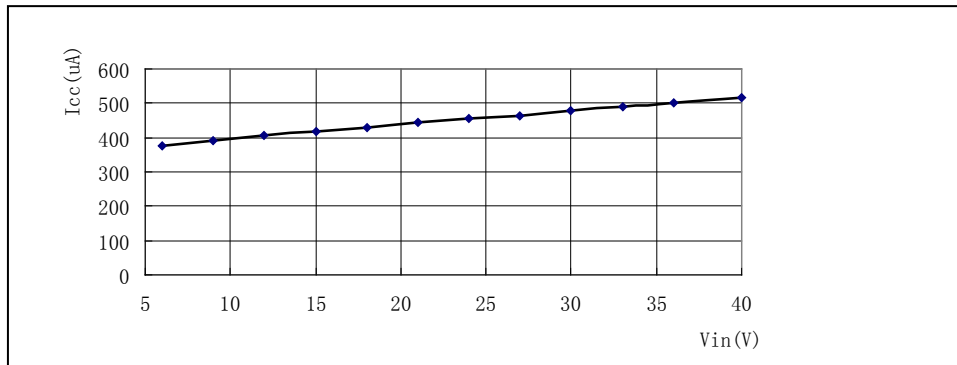
No.	PARAMETER	SYMBOL	CONDITIONS	MIN	TYP	MAX	UNIT	
1.3.1	Quiescent supply current	$I_{INQoff}$	Output off	70	120	140	$\mu\text{A}$	
		$I_{INQon}$	Output switching		450	600	$\mu\text{A}$	
1.3.2	Mean current sense threshold voltage	$V_{SENSE}$		95	100	105	mV	
1.3.3	Sense threshold hysteresis	$V_{SENSEHYS}$			$\pm 15$		%	
1.3.4	$I_{SENSE}$ pin input current	$I_{SENSE}$	$V_{SENSE} = V_{IN} - 0.1\text{V}$		8		$\mu\text{A}$	
1.3.5	Under-voltage lockout threshold	$V_{UVLO}$	$V_{IN}$ rising	5.05	5.85	6.65	V	
1.3.6	Under-voltage lockout hysteresis	$\Delta V_{UVLO}$			1.65		V	
1.3.7	Ratio of output current level to initial current in Dimming Mode 1	$K_1$	DIM1: Floating DIM2: GND	Level 1		100		%
				Level 2		50		%
				Level 3	17	20	23	%
1.3.8	Ratio of output current level to initial current in Dimming Mode 2	$K_2$	DIM1: GND DIM2: Floating	Level 1		100		%
				Level 2		60		%
				Level 3	28	30	32	%
1.3.9	Ratio of output current level to initial current in Dimming Mode 3	$K_3$	DIM1: GND DIM2: GND	Level 1		100		%
				Level 2	28	30	32	%
1.3.10	Interval time between external switch actions	$T_S$			2		s	
1.3.11	LX switch continuous current	$I_{LXmean\_0}$	ZLED7030			1.2	A	
		$I_{LXmean\_3}$	ZLED7330			1.0	A	
		$I_{LXmean\_5}$	ZLED7530			0.75	A	
		$I_{LXmean\_7}$	ZLED7730			0.35	A	
1.3.12	LX switch leakage current	$I_{LX(leak)}$			1	$\mu\text{A}$		
1.3.13	LX switch on resistance	$R_{LX}$			0.3	0.4	$\Omega$	
1.3.14	Minimum switch on time	$t_{ONmin}$	LX switch on		200		ns	
1.3.15	Minimum switch off time	$t_{OFFmin}$	LX switch off		200		ns	
1.3.16	Recommended operating frequency maximum	$f_{LXmax}$				1	MHz	

No.	PARAMETER	SYMBOL	CONDITIONS	MIN	TYP	MAX	UNIT
1.3.17	Recommended output switch duty cycle range at $f_{LXmax}$	$D_{LX}$		0.3		0.9	
1.3.18	Propagation delay of internal comparator	$t_{PD}$			25		ns
1.3.19	Thermal shutdown temperature	$T_{SD}$			150		°C
1.3.20	Thermal shutdown hysteresis	$T_{SD-HYS}$			20		K

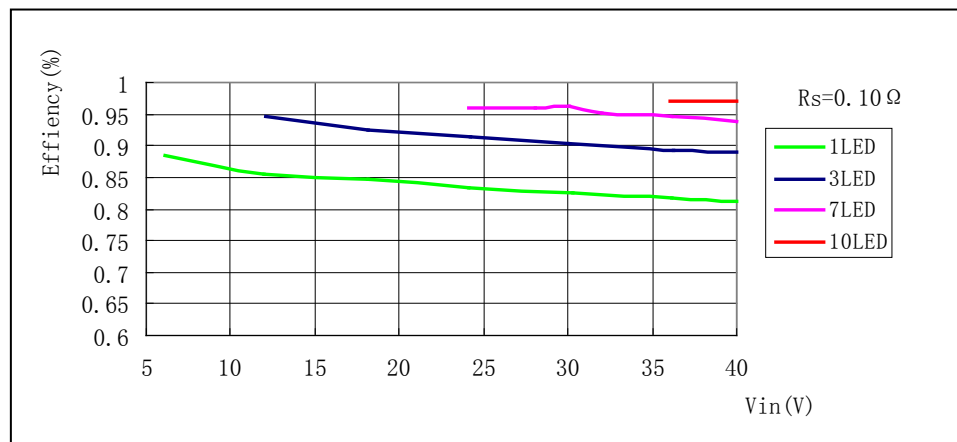
## 1.4 Typical Operation Graphs

The curves are valid for the typical application circuit and  $T_{amb} = 25^{\circ}\text{C}$  unless otherwise noted.

**Figure 1.1 ZLED7x30 Supply Operating Current vs. Input Supply Voltage ( $V_{IN} = 8.5$  to  $40\text{V}$ )**

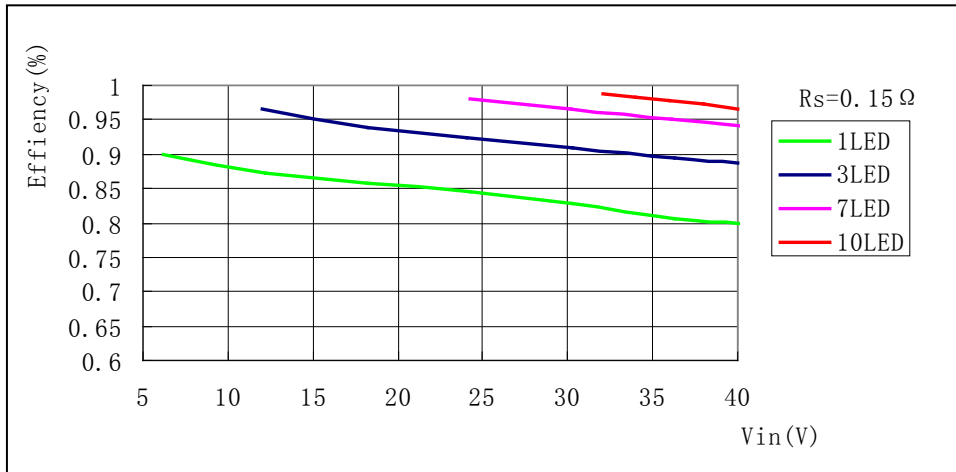


**Figure 1.2 Efficiency (%) vs. Input Supply Voltage ( $V_{IN} = 8.5$  to  $40\text{V}$ )<sup>†</sup> Per Number of LEDs ( $R_s=0.10\Omega$ ,  $L_1=47\mu\text{H}$ )**

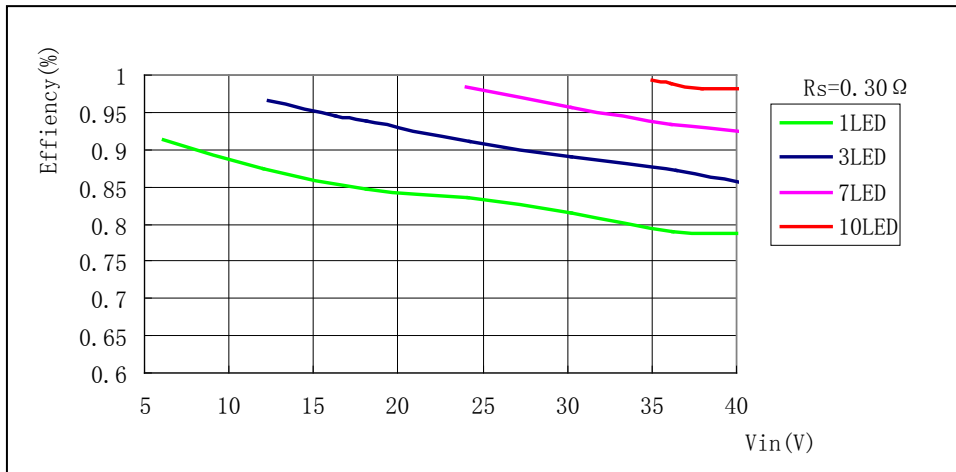


<sup>†</sup> Minimum  $V_{in}$  depends on number of LEDs.

**Figure 1.3 Efficiency vs. Input Supply Voltage ( $V_{IN} = 8.5$  to  $40V$ )<sup>‡</sup> Per Number of LEDs ( $R_s=0.15\Omega$ ,  $L_1=47\mu H$ )**

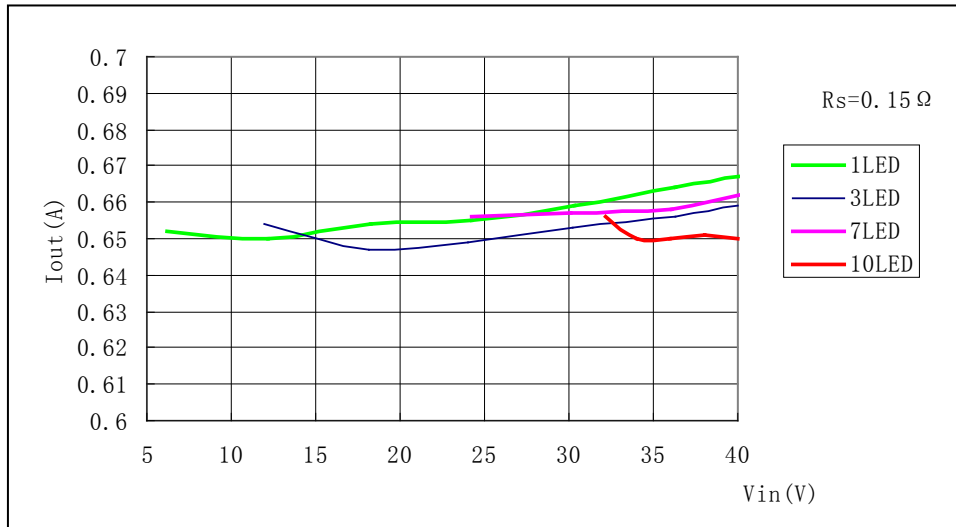


**Figure 1.4 Efficiency vs. Input Supply Voltage ( $V_{IN} = 8.5$  to  $40V$ )<sup>‡</sup> Per Number of LEDs ( $R_s=0.30\Omega$ ,  $L_1=47\mu H$ )**

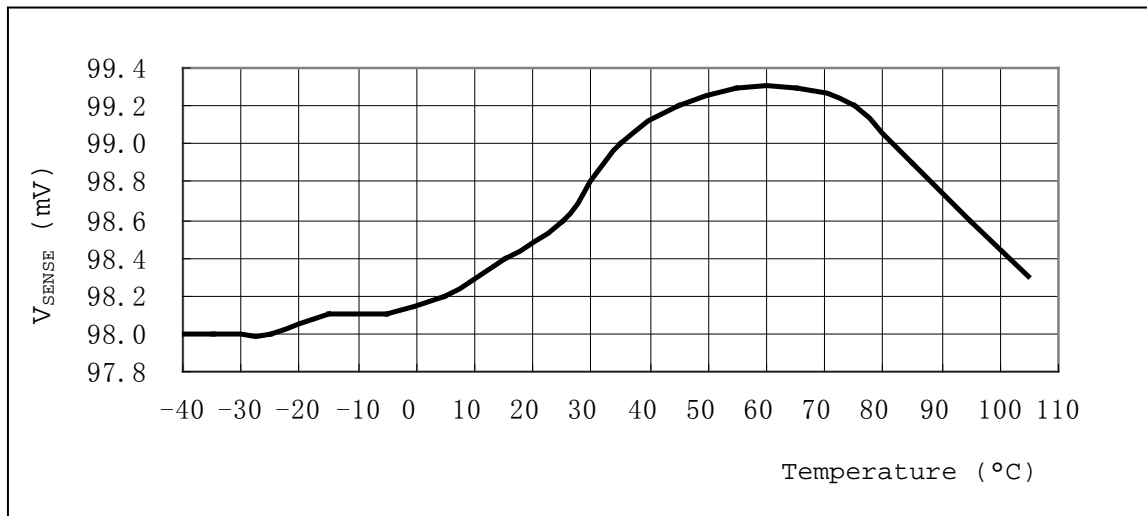


<sup>‡</sup> Minimum  $V_{in}$  depends on number of LEDs.

**Figure 1.5 Output Current Variation vs. Input Supply Voltage ( $V_{IN} = 8.5$  to  $40V$ )<sup>§</sup> Per Number of LEDs ( $R_s=0.15\Omega$ ,  $L_1=47\mu H$ )**



**Figure 1.6 Sense Voltage vs. Operating Temperature ( $R_s=0.10\Omega$ ,  $L_1=47\mu H$ ,  $V_{IN} = 40 V$ )**



<sup>§</sup> Minimum  $V_{in}$  depends on number of LEDs.

Figure 1.7 demonstrates a typical switch dimming waveform. Channel 1 (blue) is the supply voltage. Channel 4 (magenta) shows the output current at 100%, then 60%, and then 30%.

**Figure 1.7** Switch Dimming Waveform (Dimming Mode 2)

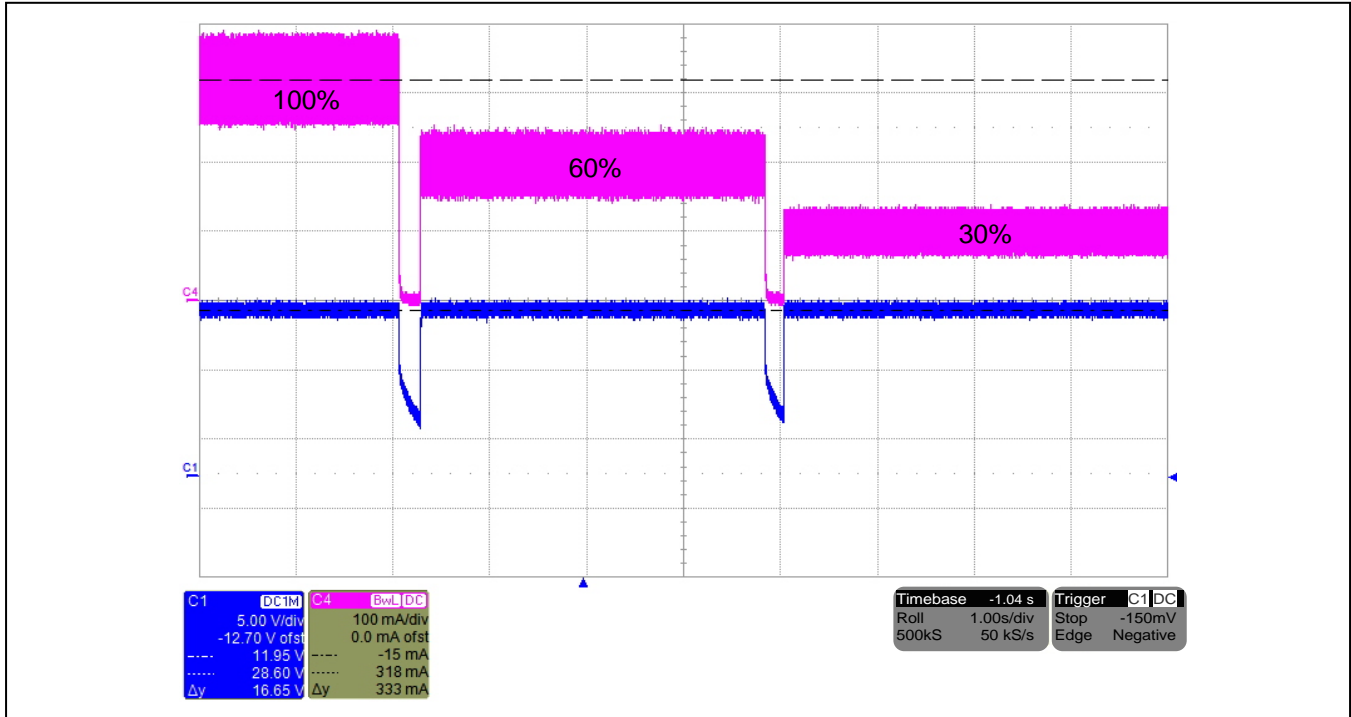
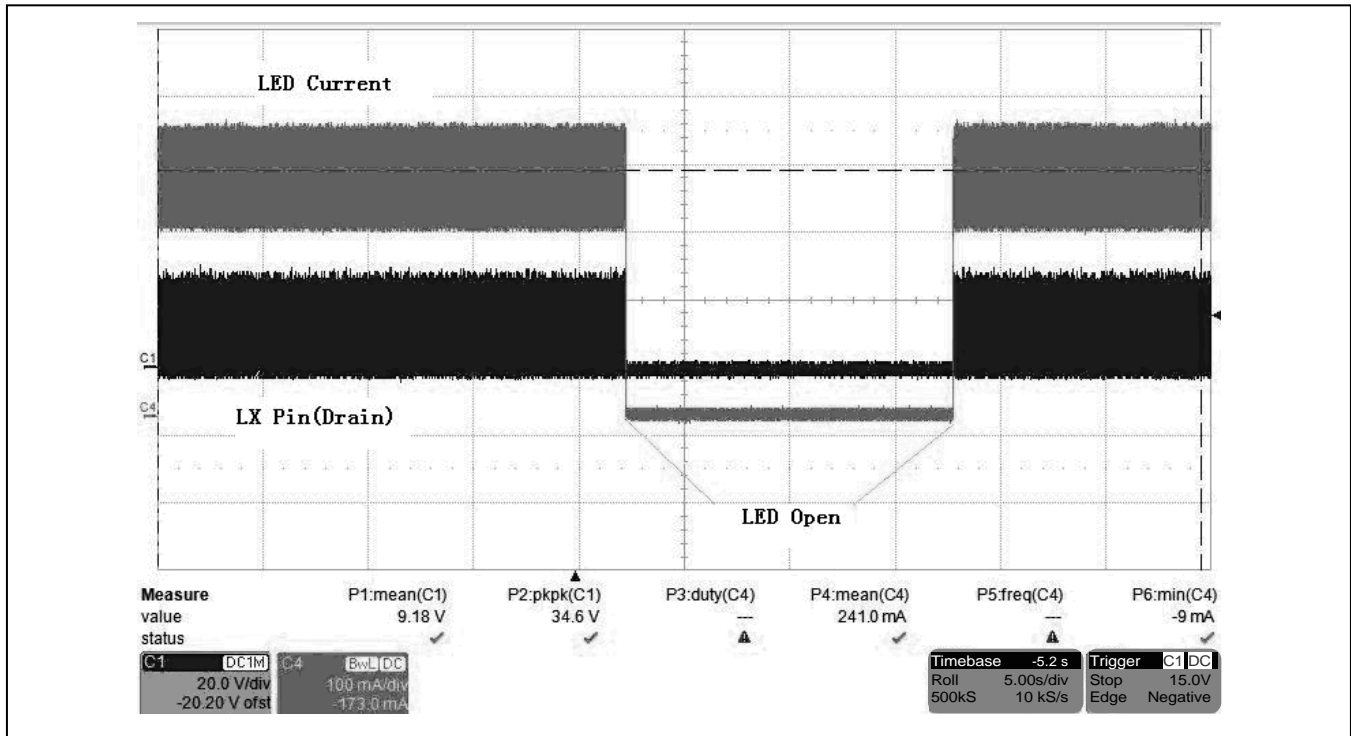


Figure 1.8 LED Open-Circuit Protection ( $R_s=0.30\Omega$ ,  $L_1=47\mu H$ ,  $V_{IN} = 24 V$ )



## 2 Circuit Description

### 2.1 ZLED7x30 Overview

The ZLED7x30 is a continuous-mode inductive step-down converter LED driver for driving single or multiple series-connected LEDs from a voltage input higher than the LED voltage ( $V_{in} = 8.5$  to 40VDC; see section 3.2.2 for important details). The ZLED7x30 provides an adjustable output current (1.2A maximum for ZLED7030; 1.0A maximum for ZLED7330; 0.75A maximum for ZLED7530; 0.35A maximum for ZLED7730), which is nominally set via an external sense resistor  $R_s$  and controlled by the ZLED7x30's integrated high-side output current-sensing circuit and output switch. The ZLED7x30 detects external switching action on the supply line to adjust the output current in different modes on different levels.

Only a resistor, a diode, an inductor, and three capacitors are needed for a typical basic application. Refer to the application circuits in section 3 for the location of the components referred to in the following sections.

### 2.2 Control of Output Current via External Sense Resistor $R_s$

External sense resistor  $R_s$ , which is connected between the  $V_{IN}$  and  $I_{SENSE}$  pins as shown in Figure 3.1, sets  $I_{OUTnom}$ , the nominal average output current. Equation (1) can be used to calculate the nominal output current, which is the LX switch output current  $I_{LX}$  if no switch dimming condition is valid. See section 3.3.1 for recommended values for  $R_s$  in a typical basic application and section 3.4 for layout guidelines for  $R_s$ .

$$I_{OUTnom} = \frac{0.4V}{R_s} \quad (1)$$

### 2.3 Multi-Mode Switch Dimming

The ZLED7x30 detects external switching action on the supply line to adjust output current, allowing dimming functionality to be achieved without changing the original lighting system circuitry. The switch dimming is implemented in either two-level mode or three-level mode. The output current of each level and the total number of levels are customer selected by setting the corresponding input conditions on the DIM1 and DIM2 pins. See page 1 for a typical application using the DIM1 and DIM2 pins.

The output current is set at the initial 100% value determined by the sense resistor  $R_s$  the first time that power is supplied to the chip. After the initial power up sequence, the chip adjusts the output current according to the external switch action. After the lowest current level, the current cycles back to the initial value if subsequent switch action is detected. If the power is switched off for longer than 2 seconds, the device will return to its initial state and the output current will be set to the initial value the next time that power is applied.

There are two types of switch action: a normal switch, which has an off-time between each subsequent switch action longer than 2s, and a dimming switch, which has an off-time between each subsequent switch less than 2s.

The dimmed average output current is given by

$$I_{OUT\ dim} = K_X * \frac{0.IV}{R_S} \quad (2)$$

### Where

$K_X$  = Current ratio to initial current (see section 1.3).

The input conditions on the DIM1 and DIM2 pins set the number of current levels and the current ratio relative to the initial average current for the dimming switch (DS) sequences as shown in Table 2.1.

**Table 2.1 Dimming Configuration Options**

Dimming Mode	DIM1	DIM2	Dimming Ratio K
No dimming	Floating	Floating	(100%)
1	Floating	GND	100% → 1 <sup>st</sup> DS → 50% → 2 <sup>nd</sup> DS → 20% → 3 <sup>rd</sup> DS → 100% ...
2	GND	Floating	100% → 1 <sup>st</sup> DS → 60% → 2 <sup>nd</sup> DS → 30% → 3 <sup>rd</sup> DS → 100% ...
3	GND	GND	100% → 1 <sup>st</sup> DS → 30% → 2 <sup>nd</sup> DS → 100% ...

If a normal switch is detected or if DIM1 and DIM2 are both floating, the output current goes back to the initial state of 100% nominal average output current. Since ZLED7x30 needs to count the time for more than 2 seconds after the switch is off during a normal switch, one capacitor (C1) equal to or greater than 220µF is required to keep the chip working in low quiescent current mode during this part of the off-time.

## 2.4 ZLED7x30 Protection Features

### 2.4.1 Thermal Shut-down Protection

The ZLED7x30 automatically protects itself from damage due to over-temperature conditions. If the ZLED7x30's temperature exceeds the thermal shutdown threshold ( $T_{SD} = 150^{\circ}\text{C}$ , typical), the ZLED7x30 will shutdown. To avoid erratic ZLED7x30 operation, a 20K hysteresis ( $T_{SD-HYS}$ ) is applied that prevents it from returning to operation until its temperature falls below the hysteresis threshold ( $T_{SD} - T_{SD-HYS}$ ). Also refer to section 3.2 for additional thermal considerations.

### 2.4.2 LED Open-Load Protection

As a step-down converter, the ZLED7x30 has inherent open-load circuit protection. Since the L1 inductor is connected in series with the LED string, the current flow is interrupted if the load is open and the LX output of the ZLED7x30 will not be damaged. This provides an advantage over other products such as boost converters, for which the internal switch can be damaged by back EMF forcing the drain above its breakdown voltage.

### 3 Application Circuit Design

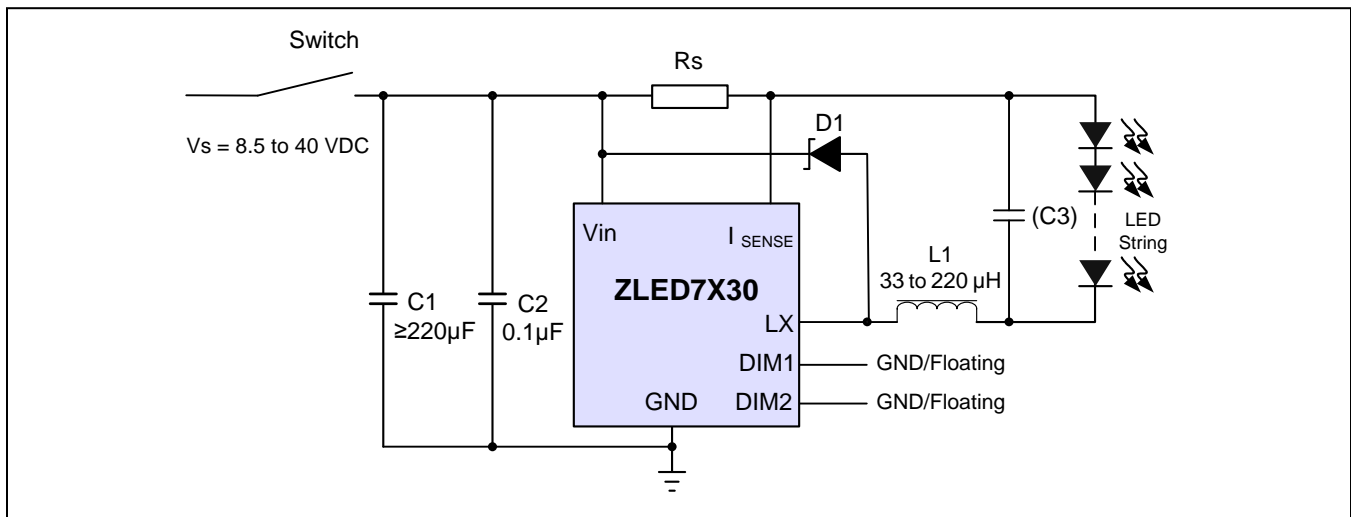
#### 3.1 Applications

The ZLED7x30 is designed for applications requiring features such as high-speed switching, variable brightness control, operation with voltages up to 40V, high efficiency, or protection from over-temperature, or open LED circuit conditions.

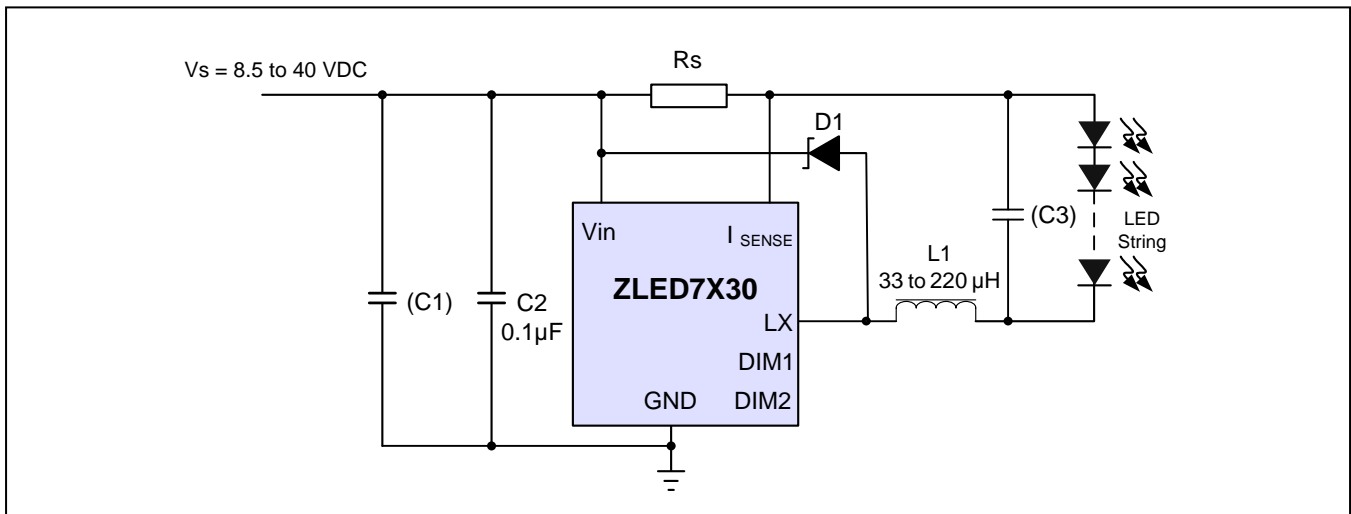
Typical applications include MR16/MR11 LED spot lights, LED street lights, parabolic aluminized reflector (PAR) LED lights, and other general purpose industrial and consumer LED applications.

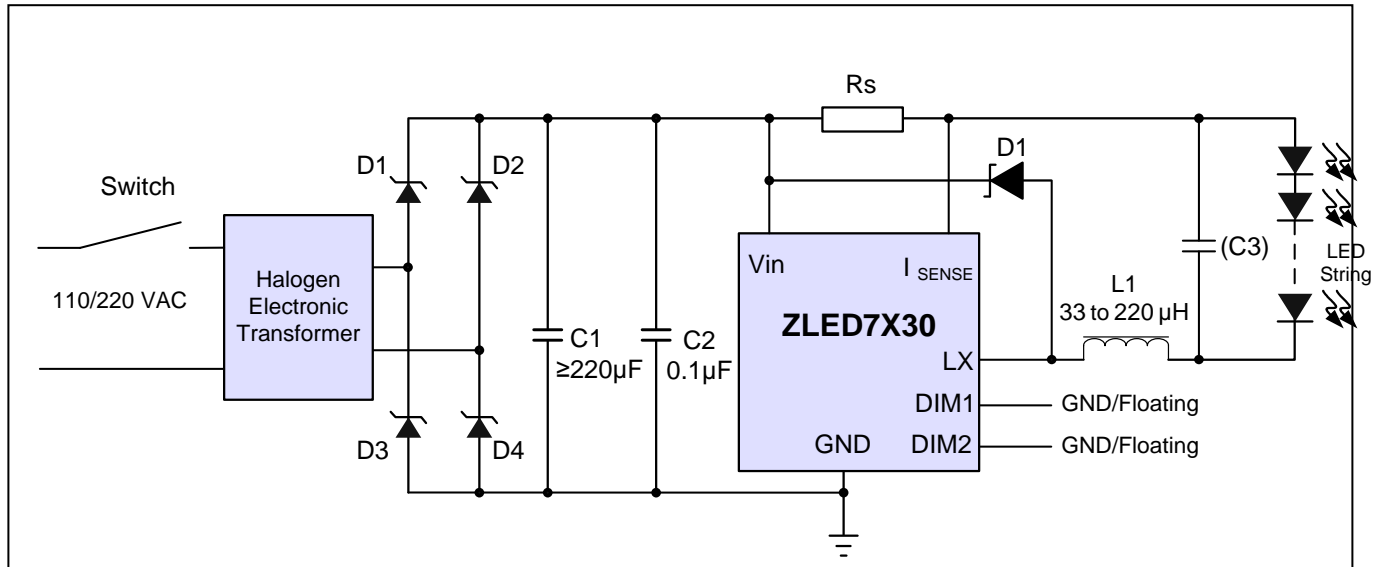
Figure 3.1 shows the minimum configuration for switch dimming applications. Figure 3.2 demonstrates the basic application circuit with the additional capacitors C1 and C3 for enhanced performance. For dimensioning of the current sense resistor, see section 2. An example of operation with a halogen lamp electronic transformer is shown in Figure 3.3.

**Figure 3.1 ZLED7x30 Application Circuit for Switch Dimming**



**Figure 3.2 Basic ZLED7x30 Application Circuit with Output Current Determined only by Rs**



**Figure 3.3 ZLED7x30 Application Circuit using a Halogen Electronic Transformer to Operate with AC Line Supply**


## 3.2 Thermal Considerations for Application Design

### 3.2.1 Temperature Effects of Load, Layout, and Component Selection

Do not exceed the package power dissipation limits by driving high load currents or by operating the chip at high ambient temperatures. Power dissipation also increases if the efficiency of the circuit is low as could result from selecting the wrong coil or from excessive parasitic output capacitance on the switch output. See the layout guidelines in section 3.4.

### 3.2.2 Temperature Effects of Low Supply Voltage $V_{IN}$

Until the supply input voltage on the  $V_{IN}$  pin has risen above the internally-set startup threshold, the ZLED7x30's internal regulator disables the drive to the internal power MOSFET output switch. Above this threshold, the MOSFET on-resistance is low enough for the chip to start to operate; however, if the supply voltage remains below the specified minimum (8.5V), the duty cycle of the output switch will be high and the ZLED7x30 power dissipation will be at a maximum. Avoid operating the ZLED7x30 under such conditions to reduce the risk of damage due to exceeding the maximum die temperature. When driving multiple LEDs, their combined forward voltage drop is typically high enough to prevent the chip from switching when  $V_{IN}$  is below 8.5V, so there is less risk of thermal damage.

## 3.3 External Component Selection

Note: Also see section 3.4 for layout guidelines for the following external components.

### 3.3.1 Sense Resistor $R_s$

Table 3.1 gives values for  $R_s$  under normal operating conditions in the typical application shown in Figure 3.1. These values assume that no dimming condition is valid. Under the conditions given the table, in order to maintain the switch current below the maximum value specified in section 1, 0.082 $\Omega$  is the minimum value for  $R_s$  for the ZLED7030, 0.1 $\Omega$  for the ZLED7330, 0.13 $\Omega$  for the ZLED7530 and 0.27 $\Omega$  for the ZLED7730.

To ensure stable output current, use a 1% accuracy resistor with adequate power tolerance and a good temperature characteristic for  $R_s$ .

**Table 3.1 Recommended Values for Sense Resistor  $R_s$**

Nominal Average Output Current (mA)	Value for $R_s$ ( $\Omega$ )
1200 (maximum for ZLED7030)	0.082
1000 (maximum for ZLED7330)	0.1
750 (maximum for ZLED7530)	0.13
667	0.15
350 (maximum for ZLED7730)	0.27
333	0.3

### 3.3.2 Inductor L1

The recommended range for the L1 inductor is 33 $\mu$ H to 220 $\mu$ H. Select the inductor value for L1 as needed to ensure that switch on/off times are optimized across the load current and supply voltage ranges. If the application requires a high supply voltage and low output current, inductance values at the high end of this range are recommended to minimize errors due to switching delays, which can reduce efficiency and increase ripple on the output. Also see section 3.4 for layout considerations for L1. Equations (3) and (4) can be used to calculate  $t_{ON}$  and  $t_{OFF}$ .

On Time for LX Switch ( $t_{ONmin} > 200ns$ ):

$$t_{ON} = \frac{L * \Delta I}{V_{IN} - V_{LED} - I_{AVG} * (R_s + r_L + R_{LX})} \quad (3)$$

Off Time for LX Switch ( $t_{OFFmin} > 200ns$ ):

$$t_{OFF} = \frac{L * \Delta I}{V_{LED} + V_D + I_{AVG} * (R_s + r_L)} \quad (4)$$

Where:

Symbol	Description
L	L1 coil inductance in H
$\Delta I$	L1 coil peak-peak ripple current in A (internally set to $0.3 * I_{AVG}$ )
$V_{IN}$	Supply voltage in V
$V_{LED}$	Total forward voltage in V for LED string
$I_{AVG}$	Nominal average LED current in A
$R_s$	External current sense resistor in $\Omega$
$r_L$	L1 coil resistance in $\Omega$
$R_{LX}$	LX switch resistance in $\Omega$
$V_D$	D1 diode forward voltage at the required load current in V

The inductance value has an equivalent effect on  $t_{ON}$  and  $t_{OFF}$  and therefore affects the switching frequency. For the same reason, the inductance has no influence on the duty cycle, for which the relationship of the summed LED forward voltages  $n * V_F$  to the input voltage  $V_{IN}$  is a reasonable approximation. Because the input voltage is a factor in the ON time, variations in the input voltage affect the switching frequency and duty cycle.

To achieve optimum performance, duty cycles close to 0.5 at the nominal average supply voltage are preferable for improving the temperature stability of the output current.

Equations (5), (6), (7), and (8) provide an example of calculating  $t_{ON}$ ,  $t_{OFF}$ , operating frequency  $f_{LX}$ , and duty cycle  $D_{LX}$  when using a 220 $\mu$ H inductor for L1 and  $V_{IN}=12V$ ,  $R_S = 0.30\Omega$ ,  $r_L=0.26\Omega$ ,  $V_{LED}=3.4V$ ,  $I_{AVG} = 333mA$ ,  $V_D=0.36V$ , and  $R_{LX}=0.27\Omega$ .

Example:

$$t_{ON} = \frac{220\mu H * 0.3 * 0.333A}{12V - 3.4V - 0.333A * (0.30\Omega + 0.26\Omega + 0.27\Omega)} = 2.64\mu s \quad (5)$$

$$t_{OFF} = \frac{220\mu H * 0.3 * 0.333A}{3.4V + 0.36V + 0.333A * (0.30\Omega + 0.26\Omega)} = 5.56\mu s \quad (6)$$

$$f_{LX} = \frac{1}{T_{ON} + T_{OFF}} = \frac{1}{2.64\mu s + 5.56\mu s} = 121.8kHz \quad (7)$$

$$D_{LX} = \frac{V_{LED}}{V_{IN}} = \frac{3.4V}{12V} \approx \frac{T_{ON}}{T_{ON} + T_{OFF}} = \frac{2.64\mu s}{2.64\mu s + 5.56\mu s} \approx 0.3 \quad (8)$$

For the L1 inductor, use a coil with a continuous current rating higher than the required mean output current and a saturation current that exceeds the peak output current by 30% to 50% for robustness against transient conditions; e.g., during start-up.

### 3.3.3 Bypass Capacitor C1

The bypass capacitor C1 has two functions: maintaining operating voltage and bypassing the current ripple of the switching converter. In general, low ESR capacitors must be used.

If the circuit is supplied by rectified line voltage, C1 must provide enough charge to maintain the ZLED7x30's minimum operating voltage as well as the forward voltage of the LED string to keep the application working even if the rectified supply voltage periodically drops below these values. A rough estimate for the minimum capacity needed can be calculated with equation (9).

$$C1_{MIN} = \frac{I_{AVG} * t_D}{\Delta V_{MAX}} = \frac{I_F * D_{LX}}{\Delta V_{MAX} * f_{LX}} \quad (9)$$

Where:

Symbol	Description
$I_{AVG}$	Average nominal LED string current assuming that the contribution of the IC supply current is negligible.
$t_D$	Discharge time at given AC frequency. Will be a maximum of 10ms (½ period duration) at 50Hz.
$\Delta V_{MAX}$	Peak rectified supply voltage minus LED string forward voltage or minimum ZLED7x30 supply voltage, whichever is greater.

Example: For an application with 3 LEDs with 3.2V forward voltage each driven at 0.33A and supplied with rectified 24VAC, a minimum bypass capacitor C1 of 220µF or 330µF might be adequate. Compared to the calculation, a safety margin of about 50% must be added to consider temperature effects and aging.

$$C1_{MIN} = \frac{0.33A * 10ms}{24V * \sqrt{2} - 3 * 3.2V} = 135 \mu F \quad (10)$$

A second function of C1 is to bypass the current ripple of the switching converter and thus prevent it from disturbing a stable IC supply or backlash on the power supply circuit. For this reason even in DC-supplied applications, the use of an adequate C1 might be useful. The defining parameters are now as shown in equation (11):

$$C1_{MIN} = \frac{I_{AVG} * t_{ON}}{V_{ripple}} \quad (11)$$

Where:

Symbol	Description
$I_{AVG}$	Average nominal LED string current.
$t_{ON}$	ON time of the internal MOSFET output switch. Note: $t_{ON}$ must be longer than $t_{ONmin}=200ns$ .
$V_{ripple}$	Permissible voltage ripple on the supply voltage.

Example: For an application of 3 LEDs driven at 0.33A and supplied with 24VDC, a maximum ripple of 10% is allowed. The ZLED7x30 is operated at 150kHz with a duty cycle of 0.4 leading to an ON time of 2.67 $\mu$ s. As calculated in equation 12, a capacitor C1 of 470nF may be adequate, again including a safety margin of about 50%.

$$C1_{MIN} = \frac{0.33A * 2.67 \mu s}{24V * 0.1} = 367nF \quad (12)$$

To achieve maximum stability over temperature and voltage, an X7R, X5R, or better dielectric is recommended while Y5V must be avoided.

### 3.3.4 De-bouncing Capacitor C2

External capacitor C2 minimizes ground bounce during switching of the internal MOSFET output switch. Ground bounce is typically caused by parasitic inductance and resistance due to the distance between the grounds for the power supply and the ZLED7x30 GND pin. Use a 0.1 $\mu$ F, X7R ceramic capacitor to ground for C2.

### 3.3.5 Capacitor C3 for Reducing Output Ripple

If required, the C3 can be used to reduce peak-to-peak ripple current in the LED string. Low ESR capacitors should be used because the efficiency of C3 largely depends on its ESR and the dynamic resistance of the LEDs. For an increased number of LEDs, using the same capacitor will be more effective. Lower ripple can be achieved with higher capacitor values, but this will increase start-up delay by reducing the slope of the LED voltage as well as cause increased current during converter start-up. The capacitor will not affect operating frequency or efficiency. For a simulation or bench optimization, C3 values of a few  $\mu$ F are an applicable starting point for the given configuration. Ripple current reduction is approximately proportional to the value of C3.

### 3.3.6 Diode D1

The flyback diode D1 must have a continuous current rating greater than the maximum output load current and a peak current rating higher than the peak L1 coil current. Important: Use a low-capacitance, fast Schottky diode that has low reverse leakage at the maximum operating temperature and maximum operating voltage for the application to avoid excess power dissipation and optimize performance and efficiency. For silicon diodes, there is a concern that the higher forward voltage and increased overshoot from reverse recovery time could increase the peak LX pin voltage ( $V_{LX}$ ). The total voltage  $V_{LX}$  (including ripple voltage) must not be >50V.

## 3.4 Application Circuit Layout Requirements

The following guidelines are strongly recommended when laying out application circuits:

- Important: Locate the L1 inductor and the C1 input decoupling capacitor as close as possible to the ZLED7x30 to minimize parasitic inductance and resistance, which can compromise efficiency. Use low resistance connections from L1 to the LX and  $V_{IN}$  pins.
- All circuit board traces to the LX pin must be as short as possible because it is a high-speed switching node.
- To minimize ground bounce, locate the 0.1 $\mu$ F external capacitor C2 as close as possible to the  $V_{IN}$  pin and solder the ZLED7x30's GND pin directly to the ground plane. (Also, see section 3.3.4 regarding ground bounce.)

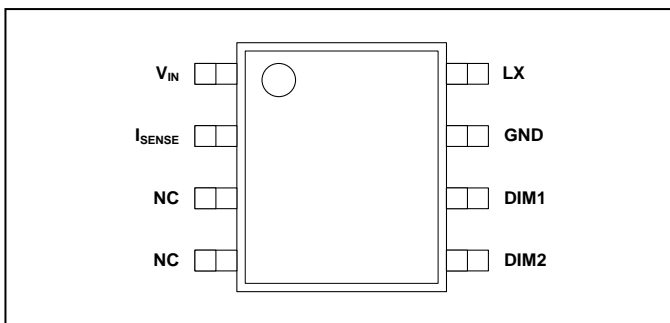
- Because  $R_S$  is typically a low value resistor, it is important to consider the resistance of the traces in series with  $R_S$  as part of the total current sense resistance. Use traces that are as short and wide as possible to minimize this effect.
- The ZLED7x30's DIM pins are high impedance inputs. When left floating, these pins are pulled up to 3.3V by internal circuitry. Avoid running high voltage traces close to the DIM pins.

## 4 ESD Protection

All pins have an ESD protection of  $\geq \pm 3000V$  according to the Human Body Model (HBM). The ESD test follows the Human Body Model with 1.5 k $\Omega$ /100 pF based on MIL 883-H, Method 3015.8.

## 5 Pin Configuration and Package

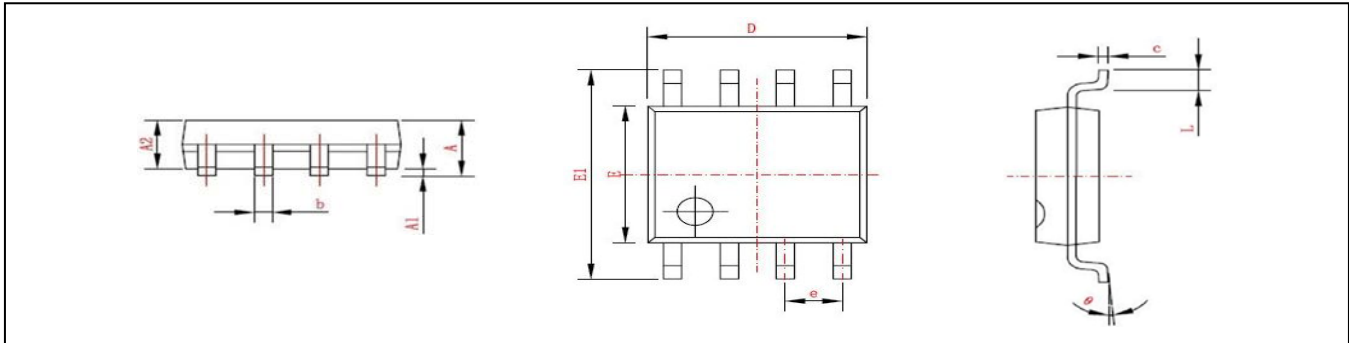
**Figure 5.1** ZLED7x30 Pin Configuration



**Table 5.1** ZLED7x30 Pin Descriptions—SOP-8 Package

Pin	No.	Description (Also see section 3.3 for layout guidelines)															
$V_{IN}$	1	Input voltage (8.5V to 40V).															
$I_{SENSE}$	2	Current adjustment input. Resistor $R_S$ from $I_{SENSE}$ to $V_{IN}$ determines the nominal average output current. $I_{OUTnom} = 0.1V/R_S$															
NC	3	Not connected; keep floating.															
NC	4	Not connected; keep floating.															
DIM2	5	Set the number of current levels and current ratio of each level of switch dimming function as follows: <table border="1" style="margin-left: 20px;"> <thead> <tr> <th>DIM1 Pin</th> <th>DIM2 Pin</th> <th>Dimming Mode</th> </tr> </thead> <tbody> <tr> <td>Floating</td> <td>Floating</td> <td>No dimming</td> </tr> <tr> <td>Floating</td> <td>GND</td> <td>Three levels: 100%, 50%, 20%</td> </tr> <tr> <td>GND</td> <td>Floating</td> <td>Three levels: 100%, 60%, 30%</td> </tr> <tr> <td>GND</td> <td>GND</td> <td>Two levels: 100%, 30%</td> </tr> </tbody> </table>	DIM1 Pin	DIM2 Pin	Dimming Mode	Floating	Floating	No dimming	Floating	GND	Three levels: 100%, 50%, 20%	GND	Floating	Three levels: 100%, 60%, 30%	GND	GND	Two levels: 100%, 30%
DIM1 Pin	DIM2 Pin		Dimming Mode														
Floating	Floating		No dimming														
Floating	GND		Three levels: 100%, 50%, 20%														
GND	Floating	Three levels: 100%, 60%, 30%															
GND	GND	Two levels: 100%, 30%															
DIM1	6																
GND	7	Connect to GND.															
LX	8	Drain of internal power switch															

## SOP8 Package Dimensions



**Table 5.2** Package Dimensions SOP-8

Symbol	Dimension (mm)		Symbol	Dimension (mm, except $\theta$ )	
	Min	Max		Min	Max
A	1.350	1.750	E	3.800	4.000
A1	0.100	0.250	E1	5.800	6.240
A2	1.450 Typical		e	1.270 Typical	
b	0.350	0.490	L	0.400	1.270
c	0.178	0.250	$\theta$	0°	8°
D	4.800	5.000			

The SOP-8 package has a thermal resistance (junction to ambient) of  $R_{\theta JA} = 128 \text{ K/W}$ .

## 6 Ordering Information

### Ordering Information

Product Sales Code	Description	Package
ZLED7030ZI1R	ZLED7030 – High Current (1200mA) 40V LED Driver with Switch Dimming	SOP-8 (Tape & Reel)
ZLED7330ZI1R	ZLED7330 – High Current (1000mA) 40V LED Driver with Switch Dimming	SOP-8 (Tape & Reel)
ZLED7530ZI1R	ZLED7330 – High Current (750mA) 40V LED Driver with Switch Dimming	SOP-8 (Tape & Reel)
ZLED7730ZI1R	ZLED7330 – High Current (350mA) 40V LED Driver with Switch Dimming	SOP-8 (Tape & Reel)
ZLED7030KIT-D1	ZLED7030 Demo Kit 12VAC/VDC, including 1 ZLED-PCB8	Kit
ZLED-PCB8	Test PCB with one 5W white High Brightness (HB) LED, cascadable to one multiple LED string	Printed Circuit Board (PCB)
ZLED-PCB2	10 unpopulated test PCBs for modular LED string with footprints of 9 common HB LED types	Printed Circuit Board (PCB)

## 7 Document Revision History

Revision	Date	Description
1.0	14 <sup>th</sup> June, 2011	First issue.
1.1	9 <sup>th</sup> August, 2011	Second issue. Updated Demo Kit description. Updated Typical Application Circuit, Figures 3.1, 3.2 and 3.3.
1.2	16 <sup>th</sup> August, 2011	Third issue. Updated to include ZLED7530 & ZLED7730. Updated Demo Kit description
	April 20, 2016	Changed to IDT branding.



Corporate Headquarters  
 6024 Silver Creek Valley Road  
 San Jose, CA 95138  
[www.IDT.com](http://www.IDT.com)

Sales  
 1-800-345-7015 or 408-284-8200  
 Fax: 408-284-2775  
[www.IDT.com/go/sales](http://www.IDT.com/go/sales)

Tech Support  
[www.IDT.com/go/support](http://www.IDT.com/go/support)

DISCLAIMER Integrated Device Technology, Inc. (IDT) reserves the right to modify the products and/or specifications described herein at any time, without notice, at IDT's sole discretion. Performance specifications and operating parameters of the described products are determined in an independent state and are not guaranteed to perform the same way when installed in customer products. The information contained herein is provided without representation or warranty of any kind, whether express or implied, including, but not limited to, the suitability of IDT's products for any particular purpose, an implied warranty of merchantability, or non-infringement of the intellectual property rights of others. This document is presented only as a guide and does not convey any license under intellectual property rights of IDT or any third parties.

IDT's products are not intended for use in applications involving extreme environmental conditions or in life support systems or similar devices where the failure or malfunction of an IDT product can be reasonably expected to significantly affect the health or safety of users. Anyone using an IDT product in such a manner does so at their own risk, absent an express, written agreement by IDT.

Integrated Device Technology, IDT and the IDT logo are trademarks or registered trademarks of IDT and its subsidiaries in the United States and other countries. Other trademarks used herein are the property of IDT or their respective third party owners. For datasheet type definitions and a glossary of common terms, visit [www.idt.com/go/glossary](http://www.idt.com/go/glossary). All contents of this document are copyright of Integrated Device Technology, Inc. All rights reserved.