



VERY HIGH SPEED NPN POWER TRANSISTORS

COMPLEMENTARY TO THE D45VM SERIES

D44VM Series

30 - 80 VOLTS
8 AMP, 50 WATTS

The D44VM is a NPN power transistor especially designed for use in switching circuits such as switching regulators, high-frequency inverters/converters and other applications where very fast switching and low-saturation voltages are necessary. This device is characterized with performance information which relates directly to switching, including 100° C maximum limits specified for switching times, saturation voltages, and leakage currents.

Features:

- Very Fast Switching $t_s \leq 500$ ns resistive
 $t_f \leq 75$ ns
- Very Low $V_{CE(sat)} \leq 0.4V$ @ $I_C = 4A$
- High Gain $H_{FE} \geq 40$ @ $I_C = 4A$

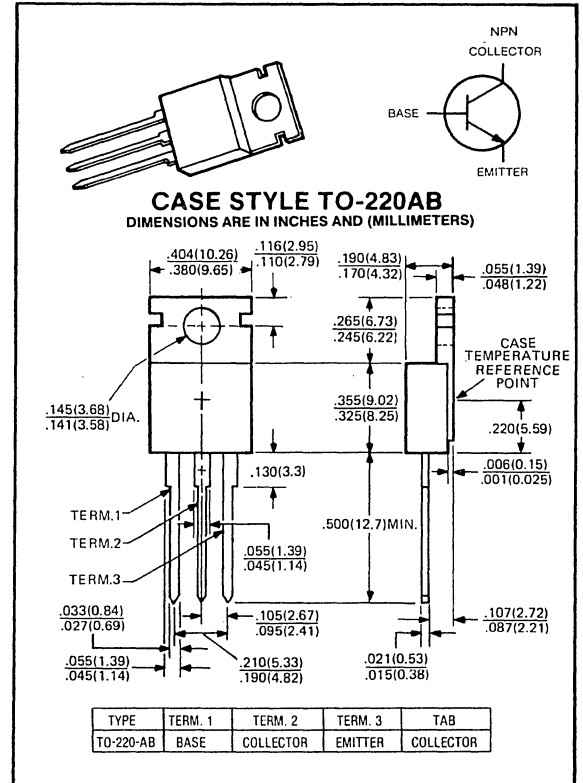

maximum ratings ($T_A = 25^\circ C$) (unless otherwise specified)

RATING	SYMBOL	D44VM1	D44VM4	D44VM7	D44VM10	UNIT
Collector-Emitter Voltage	$V_{CEO(sus)}$	30	45	60	80	V
Collector-Emitter Voltage	V_{CEX}	30	45	60	80	V
Collector-Emitter Voltage	V_{CEV}	50	70	80	100	V
Emitter Base Voltage	V_{EB}			7		V
Collector Current — Continuous	I_C			8		A
— Peak (1)	I_{CM}			20		A
Base Current — Continuous	I_B			2		A
— Peak (1)	I_{BM}			5		A
Total Power Dissipation @ $T_C = 25^\circ C$	P_D			50		Watts
Derate above $25^\circ C$				20		W/ $^\circ C$
@ $T_C = 100^\circ C$				0.4		
Operating and Storage Junction Temperature Range	T_J, T_{STG}			-55 to +150		$^\circ C$

thermal characteristics

CHARACTERISTICS	SYMBOL	MAX	UNIT
Thermal Resistance, Junction to Case	$R_{\theta JC}$	2.5	$^\circ C/W$
Thermal Resistance, Junction to Ambient	$R_{\theta JA}$	74	$^\circ C/W$
Maximum Lead Temperature for Soldering Purposes: 1/8" from Case for 5 Seconds	T_L	235	$^\circ C$

(1) Pulse measurement condition $PW \leq 6.0$ ms.

electrical characteristics ($T_C = 25^\circ\text{C}$) (unless otherwise specified)

CHARACTERISTICS	SYMBOL	MIN	MAX	UNIT
off characteristics⁽¹⁾				
Collector-Emitter Sustaining Voltage ⁽¹⁾ ($I_C = 100\text{mA}$, $I_B = 0$) D44VM1 D44VM4 D44VM7 D44VM10	$V_{CEO(sus)}$	30 45 60 80	— — — —	V
Collector-Emitter Voltage ⁽²⁾ ($I_C = 3\text{A}$, $V_{CLAMP} = \text{Rated } V_{CEX}$, $T_C \leq 100^\circ\text{C}$) D44VM1 D44VM4 D44VM7 D44VM10	V_{CEX}	30 45 60 80	— — — —	V
Collector Cutoff Current ($V_{CEV} = \text{Rated Value}$, $V_{BE(off)} = 4.0\text{V}$) ($V_{CEV} = \text{Rated Value}$, $V_{BE(off)} = 4.0\text{V}$, $T_C = 100^\circ\text{C}$)	I_{CEV}	— —	10 100	μA
Collector Cutoff Current ($V_{CE} = \text{Rated } V_{CEV}$, $R_{BE} = 50\ \Omega$, $T_C = 100^\circ\text{C}$)	I_{CER}	—	100	μA
Emitter Cutoff Current ($V_{EB} = 7\text{V}$, $I_C = 0$)	I_{EBO}	—	10	μA

second breakdown

Second Breakdown with Base Forward Biased	F_{BSOA}	SEE FIGURE 7
Second Breakdown with Base Reverse Biased	R_{BSOA}	SEE FIGURE 8

on characteristics⁽¹⁾

DC Current Gain ($I_C = 4\text{A}$, $V_{CE} = 1\text{V}$) ($I_C = 6\text{A}$, $V_{CE} = 1\text{V}$)	h_{FE}	40 20	— —	—
Collector-Emitter Saturation Voltage ($I_C = 4\text{A}$, $I_B = 0.2\text{A}$) ($I_C = 6\text{A}$, $I_B = 0.3\text{A}$) ($I_C = 8\text{A}$, $I_B = 0.8\text{A}$, $T_C = 100^\circ\text{C}$)	$V_{CE(sat)}$	— — —	0.4 0.6 1.0	V
Base-Emitter Saturation Voltage ($I_C = 4\text{A}$, $I_B = 0.2\text{A}$) ($I_C = 4\text{A}$, $I_B = 0.2\text{A}$, $T_C = 100^\circ\text{C}$)	$V_{BE(sat)}$	— —	1.2 1.2	V

dynamic characteristics

Typical

Current-Gain — Bandwidth Product ($I_C = 0.1\text{A}$, $V_{CE} = 10\text{V}$, $f_{test} = 1\text{ MHz}$)	f_T	50	MHz
Output Capacitance ($V_{CB} = 10\text{V}$, $I_E = 0$, $f_{test} = 1\text{ MHz}$)	C_{OB}	70	pF

switching characteristics

Maximum

Resistive Load (See Figure 16 for Test Circuit)					
Delay Time	$V_{CC} = 30\text{V}$, $I_C = 6\text{A}$ $I_{B1} = I_{B2} = 0.6\text{A}$ $t_p = 25\ \mu\text{sec}$	T_C	25°C	100°C	
Rise Time		t_d	30	40	nsec
Storage Time		t_r	250	350	nsec
Fall Time		t_s	500	600	nsec
		t_f	75	250	nsec
Inductive Load, Clamped (See Figure 15 for Test Circuit)					
Storage Time	$V_{CE(CLAMP)} = 30\text{V}$, $I_C = 6\text{A}$ $I_{B1} = I_{B2} = 0.6\text{A}$, $V_{BE(OFF)} = -5\text{V}$	t_s	500	600	nsec
Fall Time		t_f	70	100	nsec
		Typical			
Storage Time	$L = 200\ \mu\text{h}$	t_s	340	430	nsec
Fall Time		t_f	40	57	nsec

(1) Pulse Duration = 300 μsec , Duty Factor $\leq 2\%$.

(2) See Figure 15 for Test Circuit.

TYPICAL DC CHARACTERISTICS

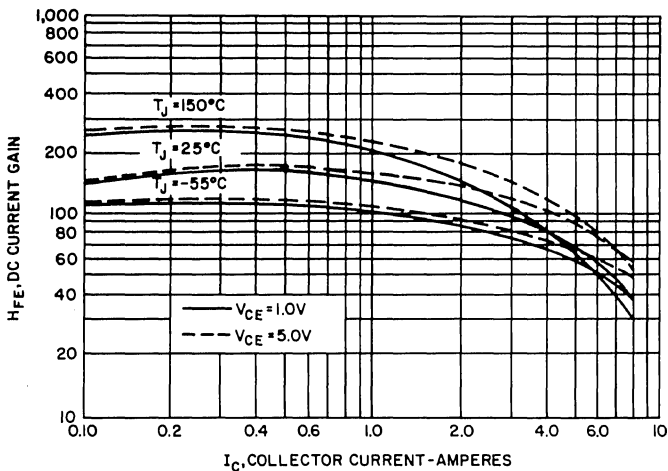

FIGURE 1. DC CURRENT GAIN

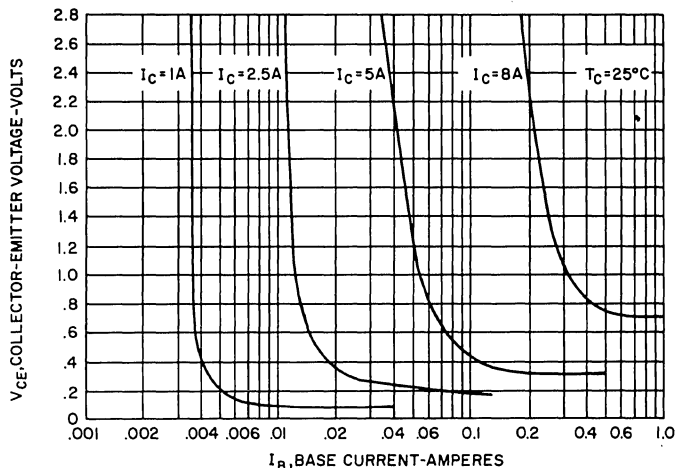

FIGURE 2. COLLECTOR SATURATION REGION

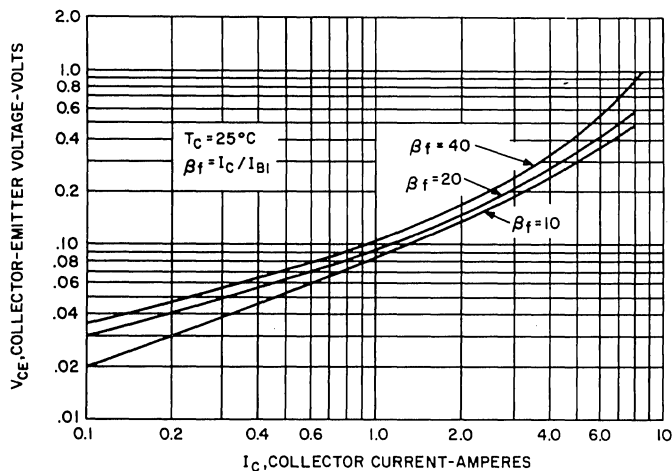

FIGURE 3. $V_{CE(SAT)}$ VS. I_C

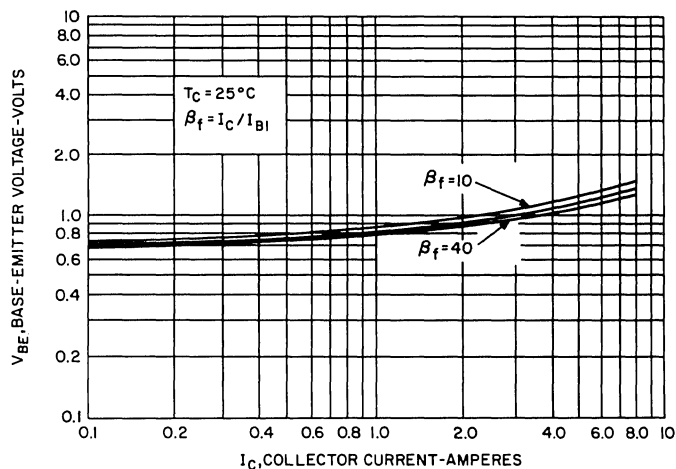

FIGURE 4. $V_{BE(SAT)}$ VS. I_C

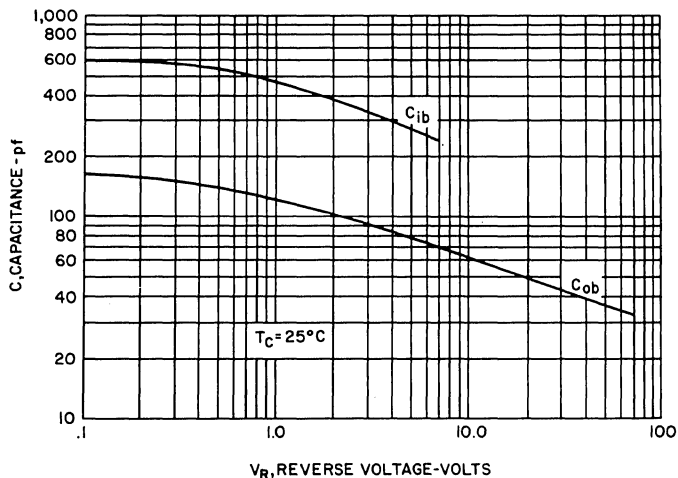

FIGURE 5. CAPACITANCE

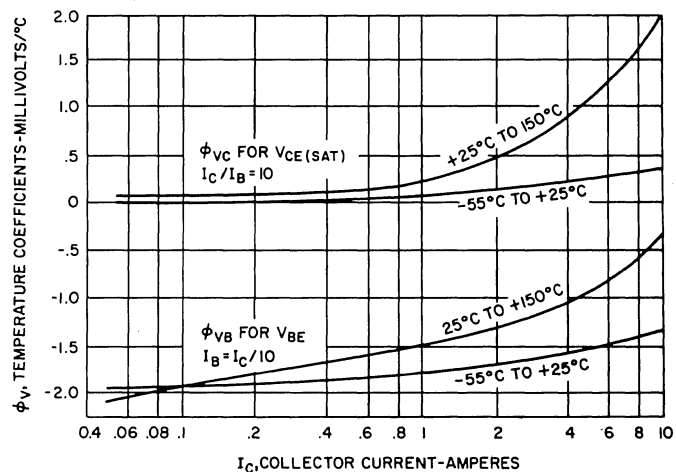

FIGURE 6. SATURATION VOLTAGE TEMPERATURE COEFFICIENTS

SAFE OPERATING AREA

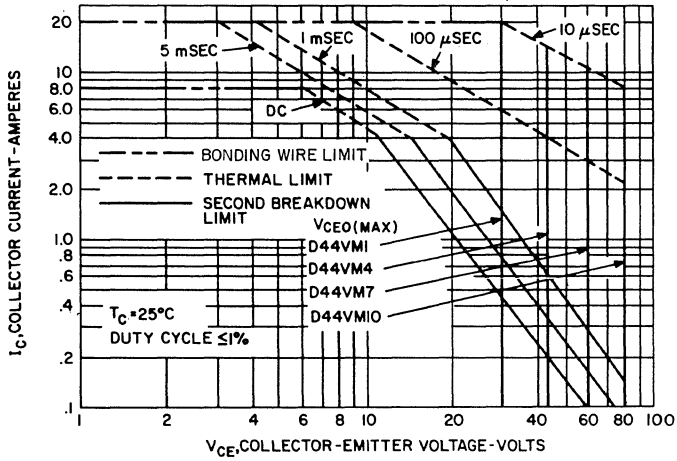

FIGURE 7. FORWARD BIAS SOA

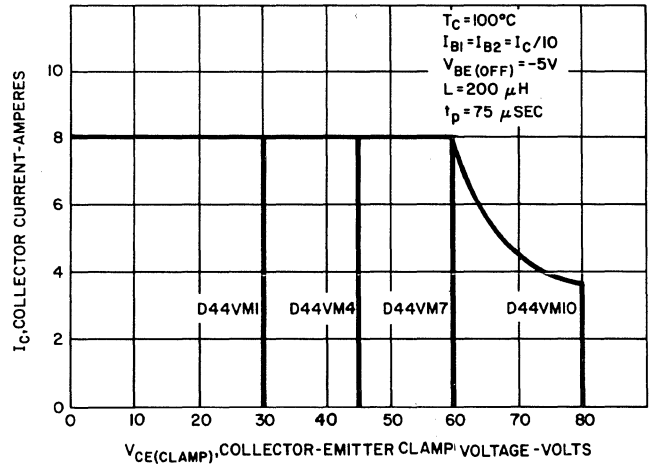

FIGURE 8. CLAMPED REVERSE BIAS SOA

TYPICAL SWITCHING CHARACTERISTICS

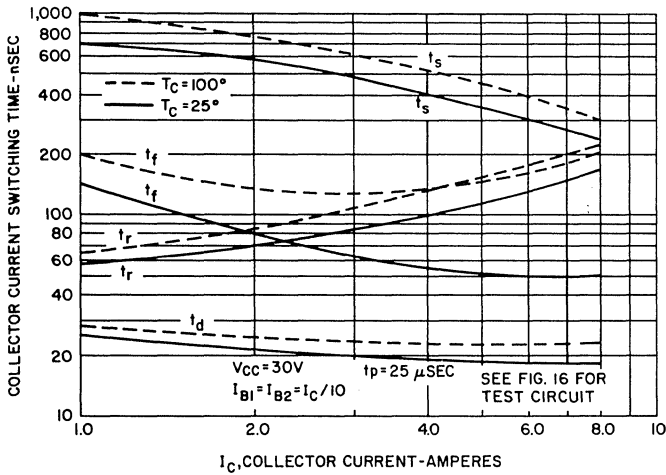

FIGURE 9. RESISTIVE SWITCHING TIME

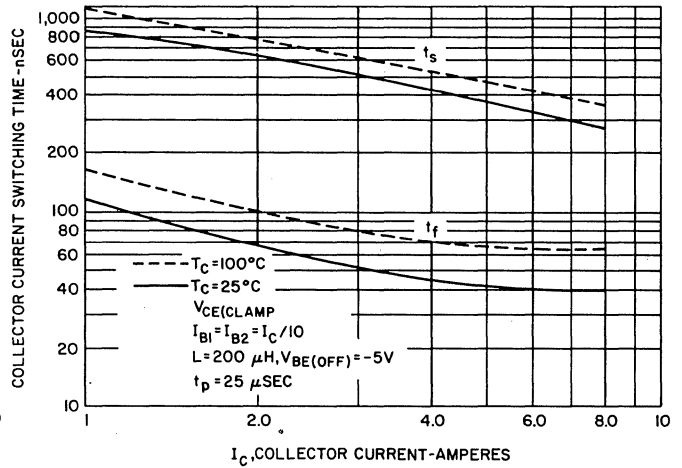

FIGURE 10. CLAMP INDUCTIVE TURN-OFF TIME

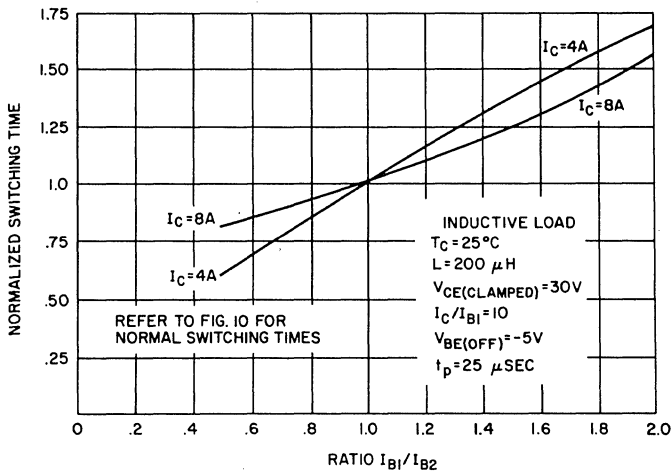

FIGURE 11. STORAGE TIME VARIATION WITH I_{B2}

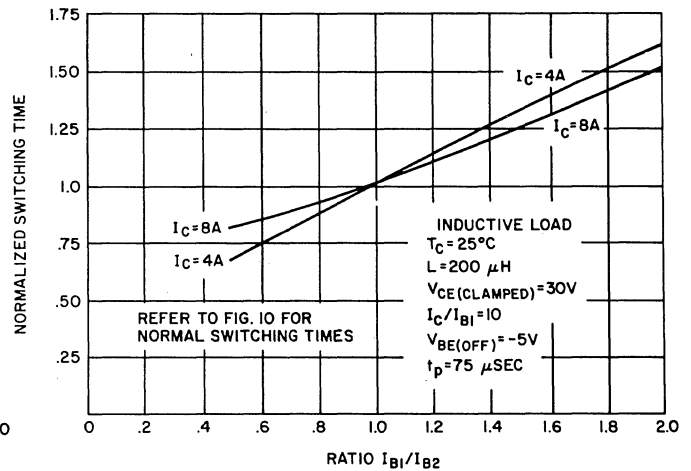

FIGURE 12. FALL TIME VARIATION WITH I_{B2}

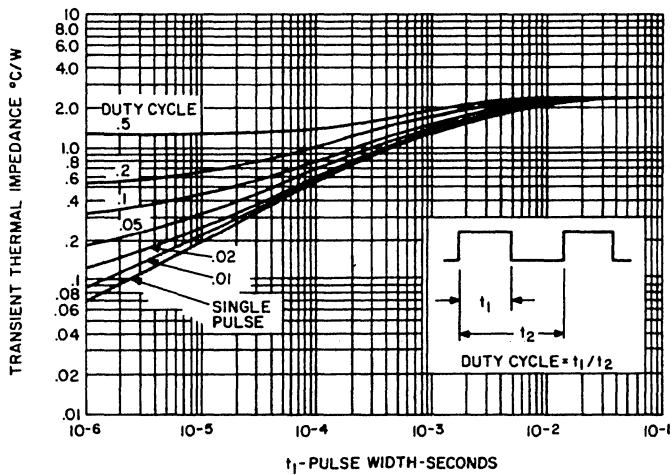

FIGURE 13. TRANSIENT THERMAL RESPONSE

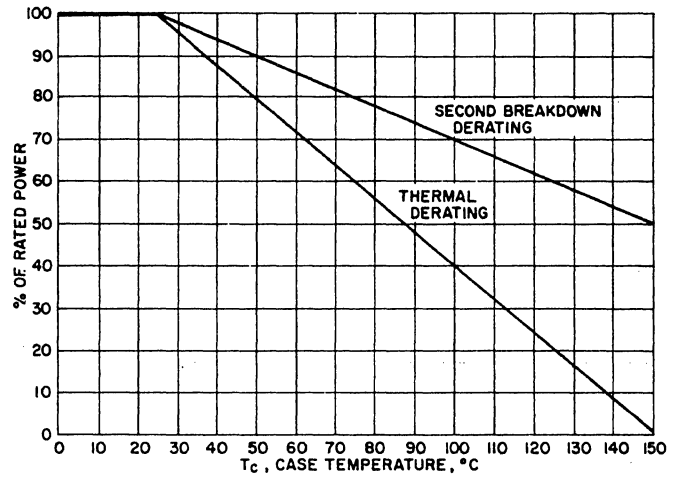

FIGURE 14. POWER DERATING FACTOR

TEST CIRCUITS

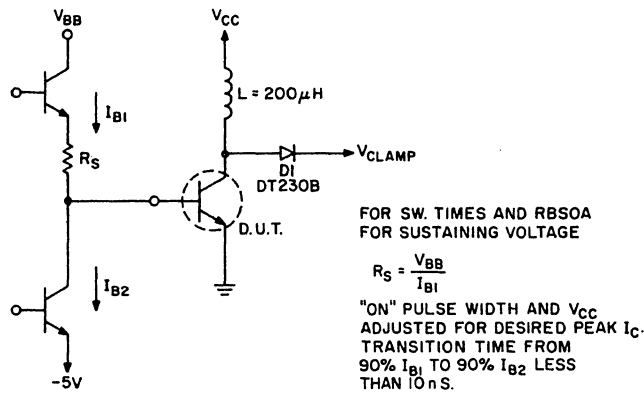

FIGURE 15. INDUCTIVE SWITCHING AND V_{CEX}

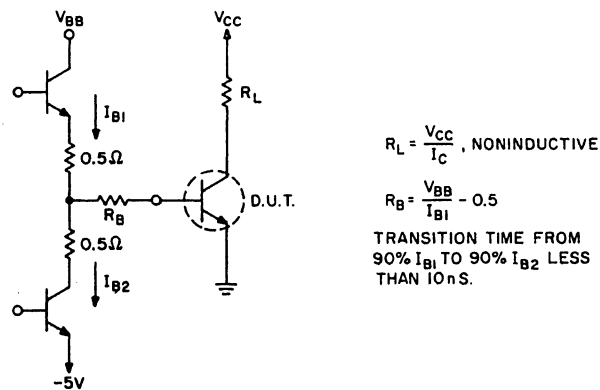

FIGURE 16. RESISTIVE SWITCHING