

High Accuracy Linear Temperature Sensor Monolithic IC MM1522

Outline

This IC is a high accuracy temperature sensor IC that output linear voltage with respect to temperature variations. The operating temperature range is from -40°C to $+125^{\circ}\text{C}$, and the operating supply voltage is from 2.7V to 10V. Compared to the conventional thermistors, it provides excellent linearity with the temperature error of $\pm 3^{\circ}\text{C}$ (max.). In addition, it provides low current consumption as low as $70\mu\text{A}$ typ. ($T_a=35^{\circ}\text{C}$), which is ideal for being used in low-power applications.

Features

1. High temperature accuracy
2. Low current consumption
3. High linearity between temperature and output voltage
4. Wide operating supply voltage range
5. High input stability
6. High load stability

Packages

SC-82ABA
SOT-25A

Applications

1. PCs
2. Disc drives
3. Printers
4. Power supply modules
5. Battery packs, chargers

Phased Out Products

Block Diagram

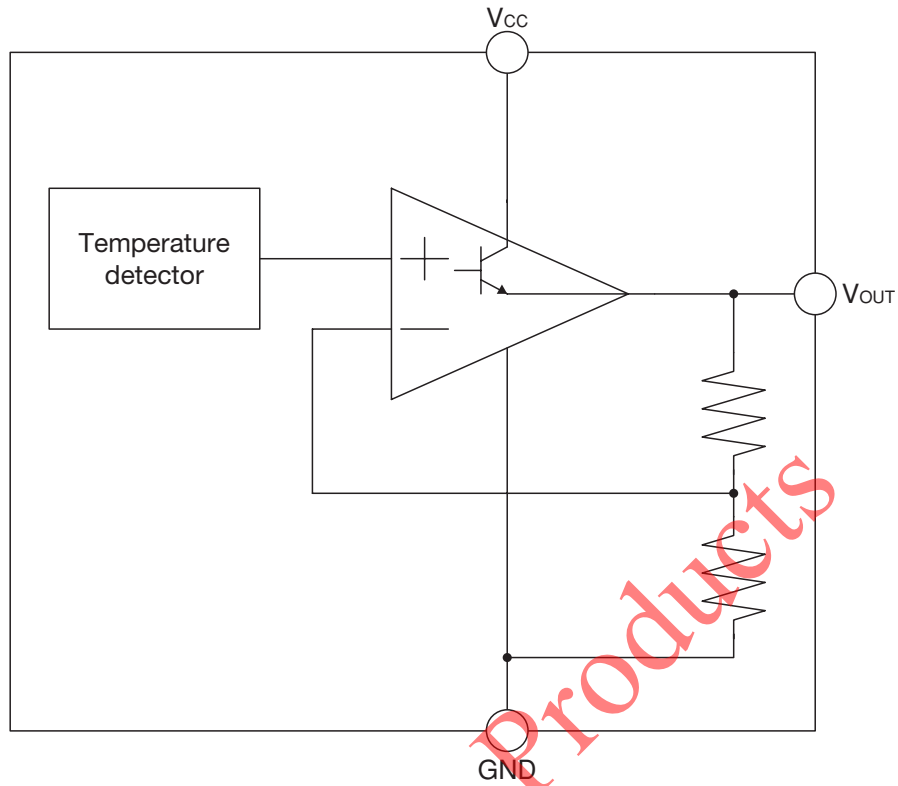

Pin Assignment

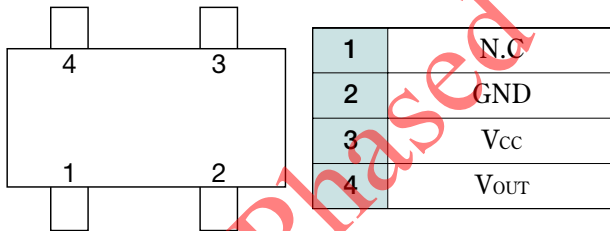

SC-82ABA
(TOP VIEW)

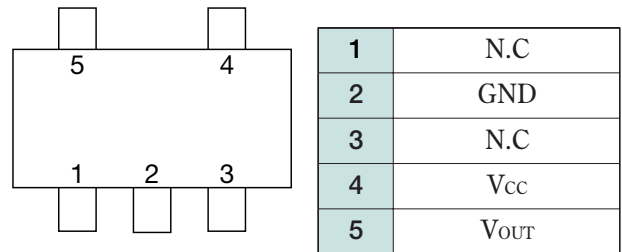

SOT-25A
(TOP VIEW)

Pin Description

■ SC-82ABA

Pin No.	Pin name	Function
1	N.C	
2	GND	Ground pin
3	Vcc	Vcc pin
4	VOUT	Output pin

■ SOT-25A

Pin No.	Pin name	Function
1, 3	N.C	
2	GND	Ground pin
4	Vcc	Vcc pin
5	VOUT	Output pin

Absolute Maximum Ratings (Ta=25°C)

Item	Symbol	Ratings	Units
Storage temperature	T _{STG}	-55~+150	°C
Operating temperature	T _{OPR}	-40~+125	°C
Supply voltage	V _{CCmax}	+13	V
Allowable loss	Pd	200 (SC-82ABA) 240 (SOT-25A)	mW

Recommended Operating Conditions

Item	Symbol	Ratings	Units
Operating temperature	T _{OPR}	-40~+125	°C
Operating supply voltage	V _{CCOPR}	+2.7~+10	V

Electrical Characteristics (Except where noted otherwise Ta=-25°C~+100°C, V_{CC}=3V, I_{OUT}=0μA)

Item	Symbol	Measurement conditions	Min.	Typ.	Max.	Units
Accuracy	Ac				±3	°C
Current consumption	I _{CC}	V _{CC} =+2.7~+10V		70	110	μA
Output voltage *1	V _{OUT}	Ta=-25°C	0.24	0.27	0.30	V
		Ta=+30°C	0.79	0.82	0.85	V
		Ta=+100°C	1.49	1.52	1.55	V
Temperature sensitivity *2	V _{se}			10		mV/°C
Nonlinearity *3	ΔNL				±0.8*	°C
Line regulation	LineReg	Ta=+30°C V _{CC} =+2.7~+10V		0	±1.0	mV/V
Load regulation	LoadReg	Ta=+30°C I _{OUT} =0~400μA		0	1	μV/μA
Temperature sensitivity of current consumption	I _{se}	Ta=-40~+125°C		0.2		μA/°C

*: Design guarantee value

Note1: *1 Output voltage: V_{OUT}

Terminal voltage at the time of Ta=-25°C, 30°C, and 100°C.

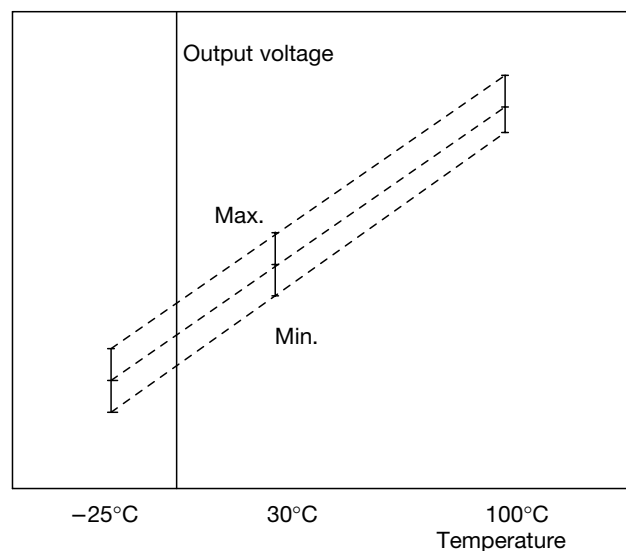

Note2: *2 Temperature sensitivity: V_{se}

Temperature coefficient of output voltage calculated from output voltage at the time of $T_a = -25^\circ\text{C}$ and $+100^\circ\text{C}$.

$$V_{se} = (V_{OUT}(100^\circ\text{C}) - V_{OUT}(-25^\circ\text{C})) / 125$$

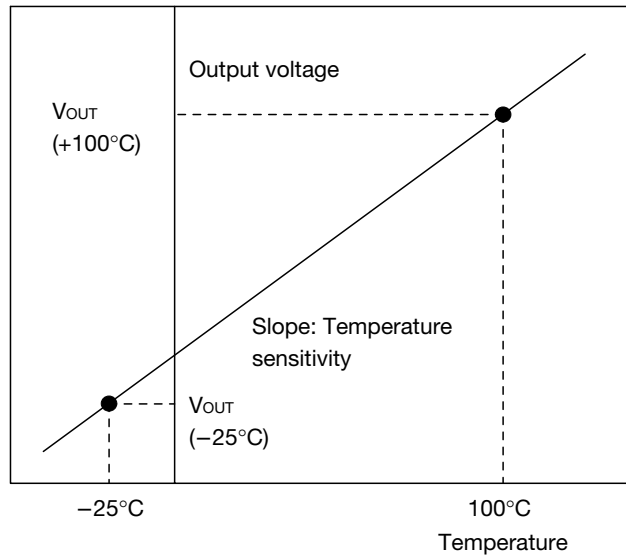

Note3: *3 Nonlinearity: ΔNL

Characteristic curve of output voltage and deflection with the approximation straight line.

In temperature range from -25 to $+100^\circ\text{C}$, the approximation straight line and the maximum deflection of the temperature of the measurement value among output voltages obtained from the approximation straight line. It assumes the approximation straight line to be a straight line to which a is minimized.

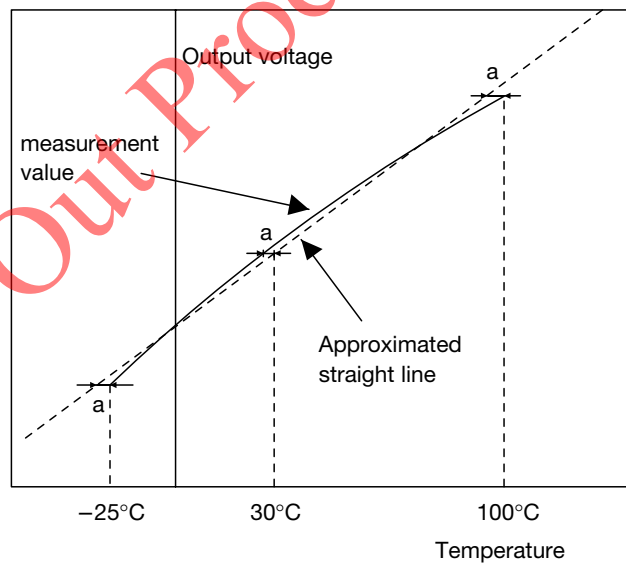

Measuring Circuit

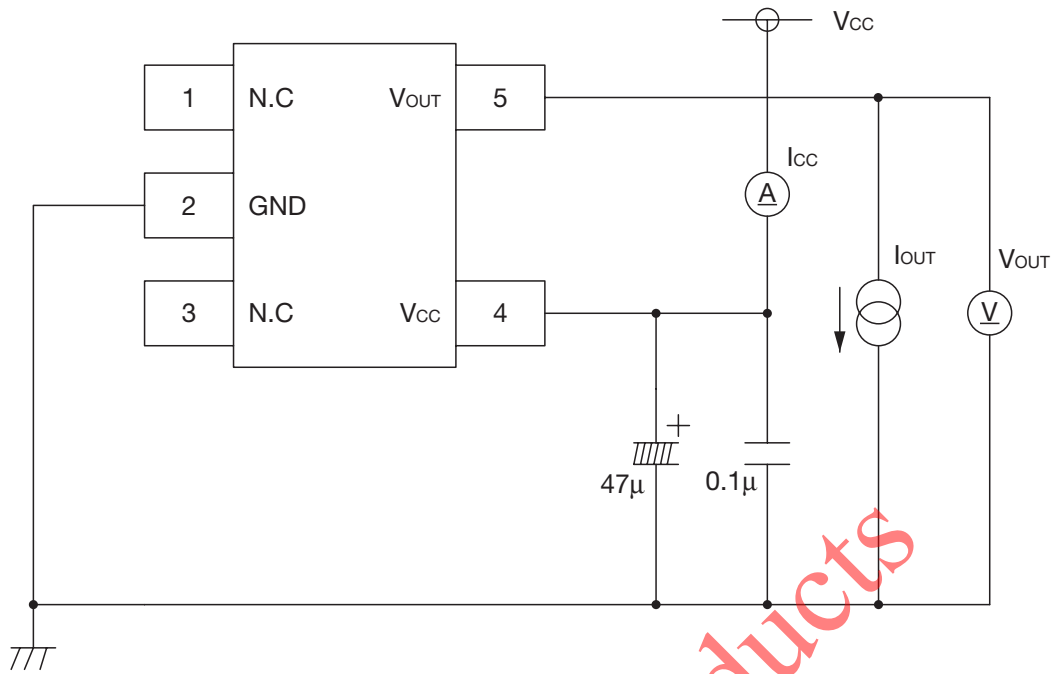

Phased Out Products

Application Circuit

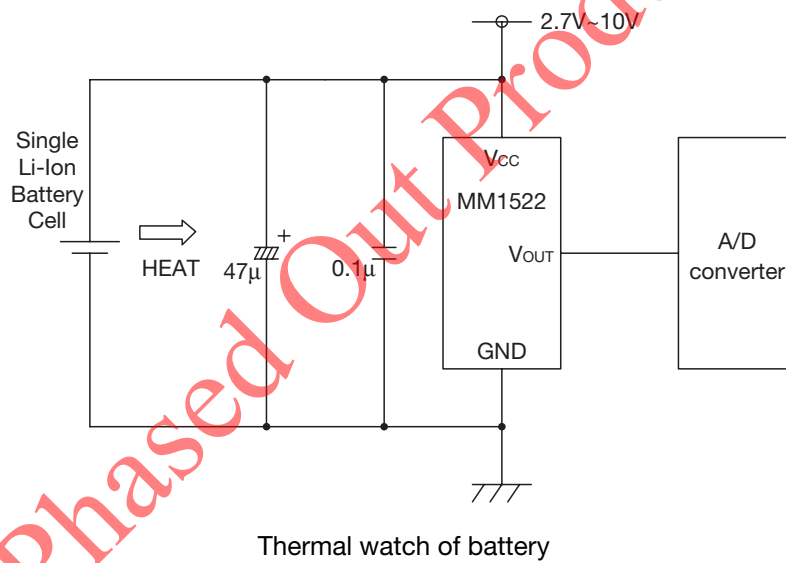
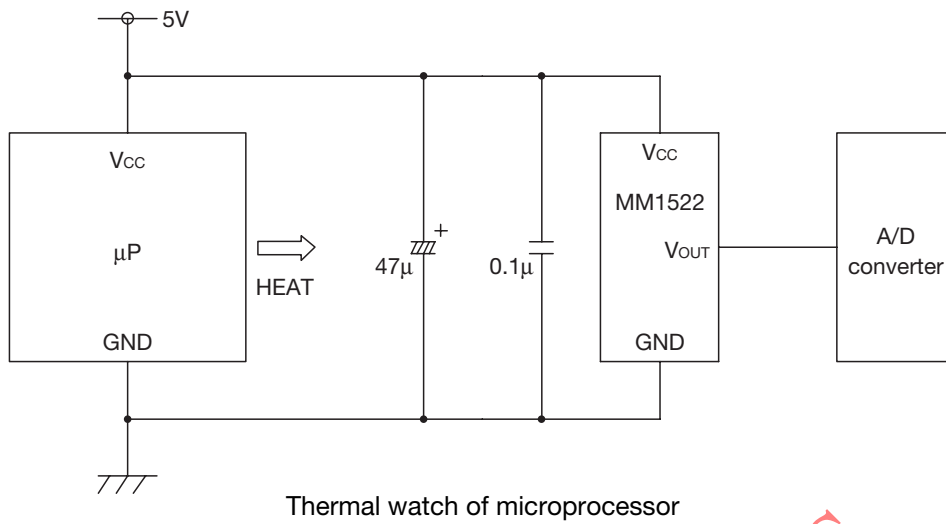

Phased Out Products

- We shall not be liable for any trouble or damage caused by using this circuit.
- In the event a problem which may affect industrial property or any other rights of us or a third party happens during the use of information in these circuit, Mitsumi Electric Co., Ltd. shall not be liable for any problem, nor grant a license therefor.

Characteristics

Output voltage – Temperature

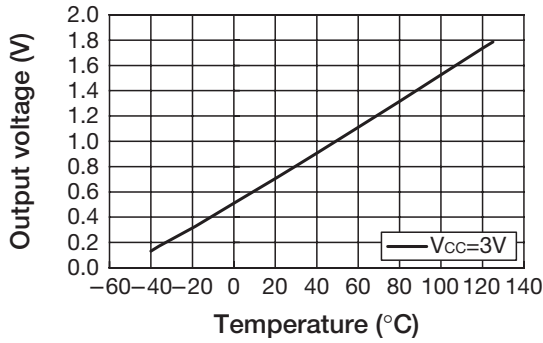

Current consumption – Temperature

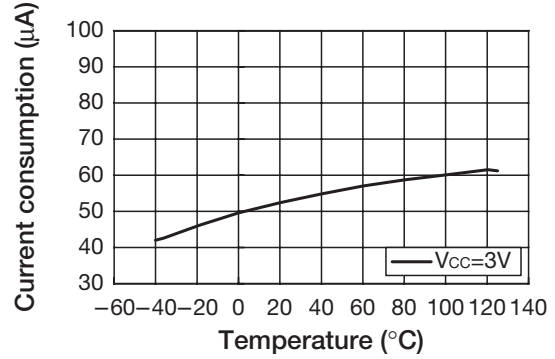

Output voltage – Supply voltage

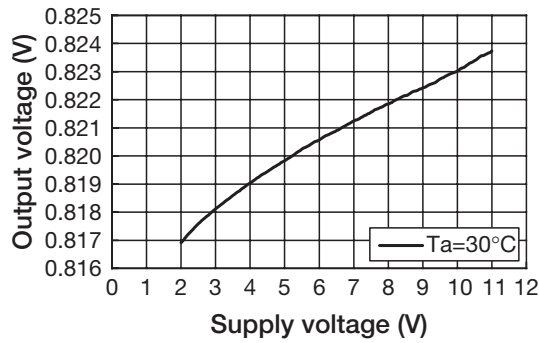

Current consumption – supply voltage

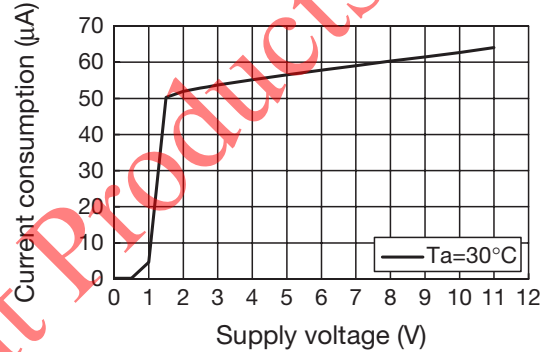

Start-up response

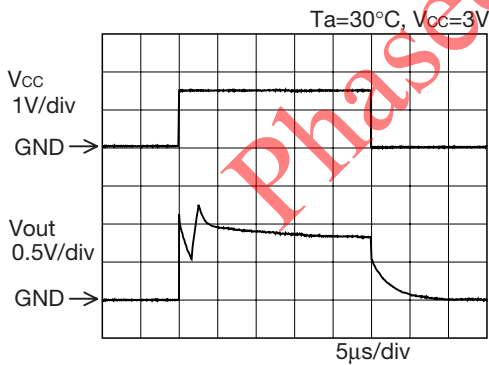

Accuracy – Temperature

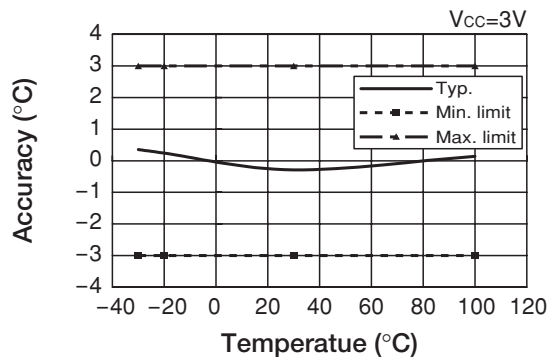

Note: these are typical characteristics