

The 4435 uses advanced trench technology to provide excellent $R_{DS(ON)}$ and low gate charge. This device is suitable for use as a load switch or in PWM applications.

GENERAL FEATURES

- $R_{DS(ON)} < 18m\Omega @ V_{GS} = -10V$
 $R_{DS(ON)} < 26m\Omega @ V_{GS} = -4.5V$
- High Power and current handling capability
- Lead free product is acquired
- Surface Mount Package

Application

- PWM applications
- Load switch
- Power management

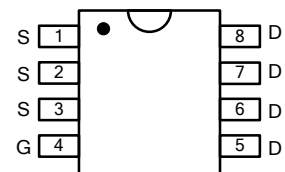
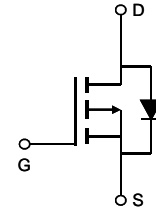

Marking and pin assignment

ABSOLUTE MAXIMUM RATINGS($T_A=25^{\circ}C$ unless otherwise noted)

Parameter	Symbol	Maximum	Unit
Drain-source Voltage	V_{DS}	-30	V
Gate-source Voltage	V_{GS}	± 20	V
Drain Current	I_D	$T_A=25^{\circ}C @ \text{Steady State}$	-10
		$T_A=70^{\circ}C @ \text{Steady State}$	-8
Pulsed Drain Current ^A	I_{DM}	-50	A
Total Power Dissipation @ $T_A=25^{\circ}C$	P_D	3.0	W
Thermal Resistance Junction-to-Ambient @ Steady State ^B	$R_{\theta JA}$	42	$^{\circ}C/W$
Junction and Storage Temperature Range	T_J, T_{STG}	-55~+150	$^{\circ}C$

ELECTRICAL CHARACTERISTICS (T_A=25°C unless otherwise noted)

Parameter	Symbol	Conditions	Min	Typ	Max	Units
Static Parameter						
Drain-Source Breakdown Voltage	BV _{DSS}	V _{GS} = 0V, I _D =-250μA	-30			V
Zero Gate Voltage Drain Current	I _{DSS}	V _{DS} =-30V, V _{GS} =0V, T _C =25°C			-1	μA
Gate-Body Leakage Current	I _{GSS}	V _{GS} = ±20V, V _{DS} =0V			±100	nA
Gate Threshold Voltage	V _{GS(th)}	V _{DS} = V _{GS} , I _D =-250μA	-1.0	-1.5	-2.5	V
Static Drain-Source On-Resistance	R _{DS(ON)}	V _{GS} = -10V, I _D =-10A		16	18	mΩ
		V _{GS} = -4.5V, I _D =-5.0A		21.5	26	
Diode Forward Voltage	V _{SD}	I _S =-10A, V _{GS} =0V		-0.8	-1.2	V
Maximum Body-Diode Continuous Current	I _S				-10	A
Dynamic Parameters						
Input Capacitance	C _{iss}	V _{DS} =-15V, V _{GS} =0V, f=1MHZ		1500		pF
Output Capacitance	C _{oss}			327		
Reverse Transfer Capacitance	C _{rss}			276		
Switching Parameters						
Total Gate Charge	Q _g	V _{GS} =-10V, V _{DS} =-15V, I _D =-9.1A		30		nC
Gate Source Charge	Q _{gs}			5.3		
Gate Drain Charge	Q _{gd}			7.6		
Turn-on Delay Time	t _{D(on)}	V _{GS} =-10V, V _{DS} =-15V, I _D =-6A, R _{GEN} =2.5Ω		14		ns
Turn-on Rise Time	t _r			20		
Turn-off Delay Time	t _{D(off)}			95		
Turn-off Fall Time	t _f			65		

- A. Repetitive Rating: Pulse width limited by maximum junction temperature.
 B. Surface Mounted on FR4 Board, t ≤ 10 sec.

TYPICAL ELECTRICAL AND THERMAL CHARACTERISTICS

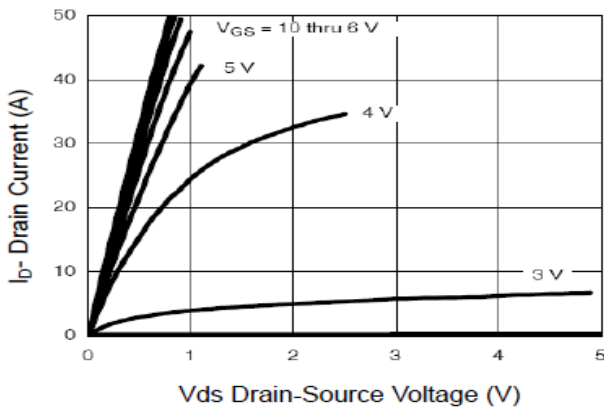

Figure1. Output Characteristics

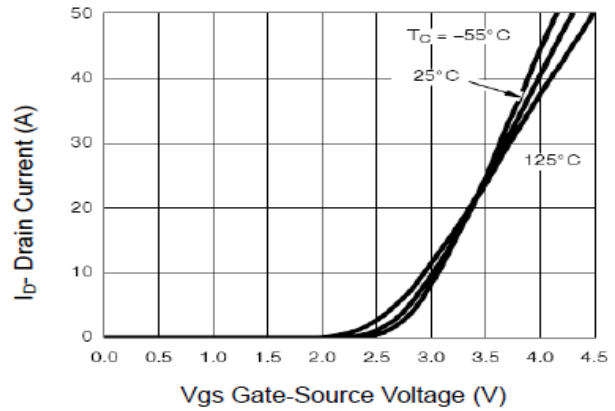

Figure2. Transfer Characteristics

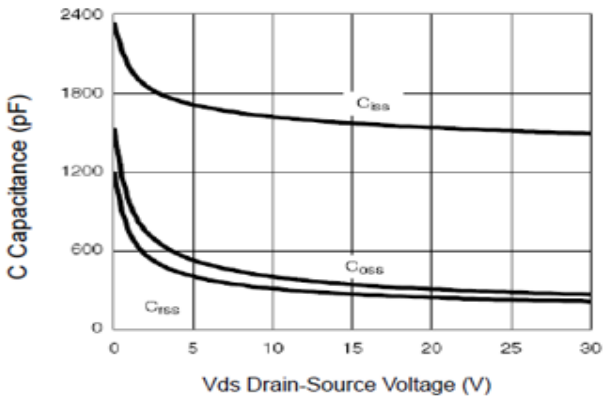

Figure3. Capacitance Characteristics

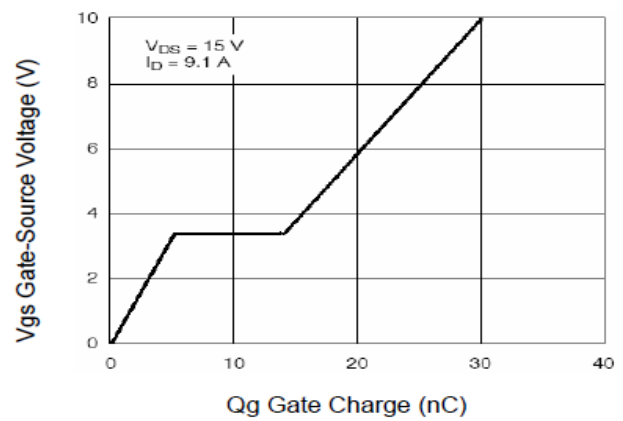

Figure4. Gate Charge

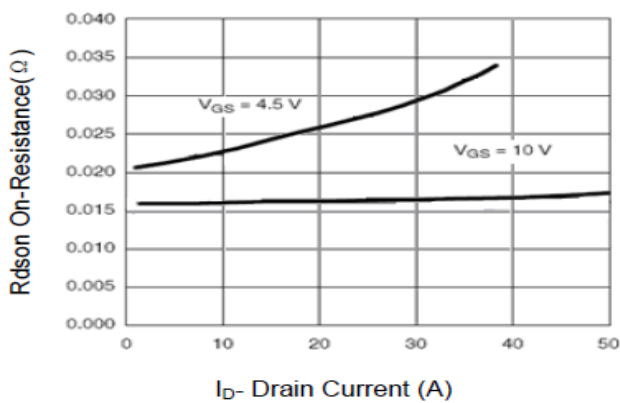

Figure5. Drain-Source on Resistance

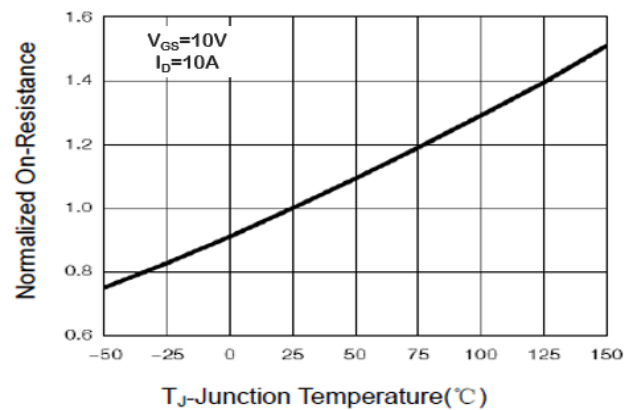

Figure6. Drain-Source on Resistance

TYPICAL ELECTRICAL AND THERMAL CHARACTERISTICS

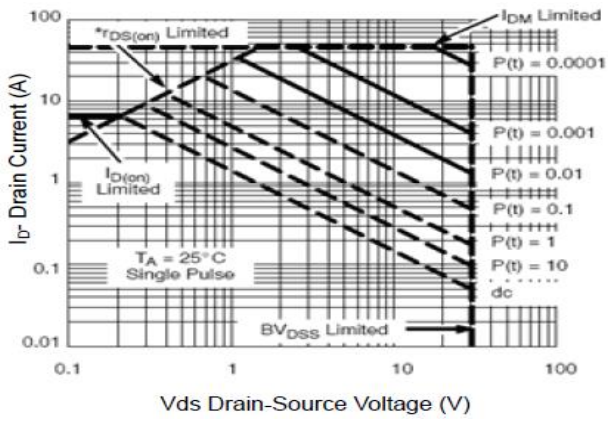

Figure7. Safe Operation Area

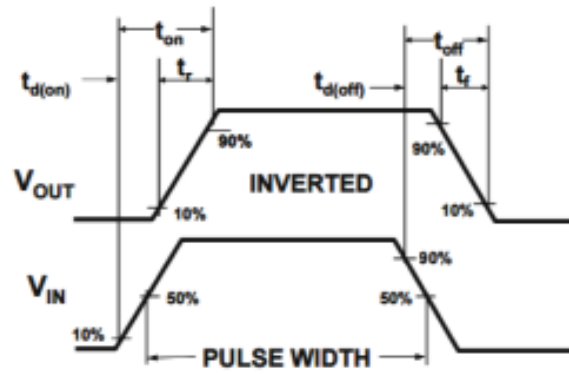
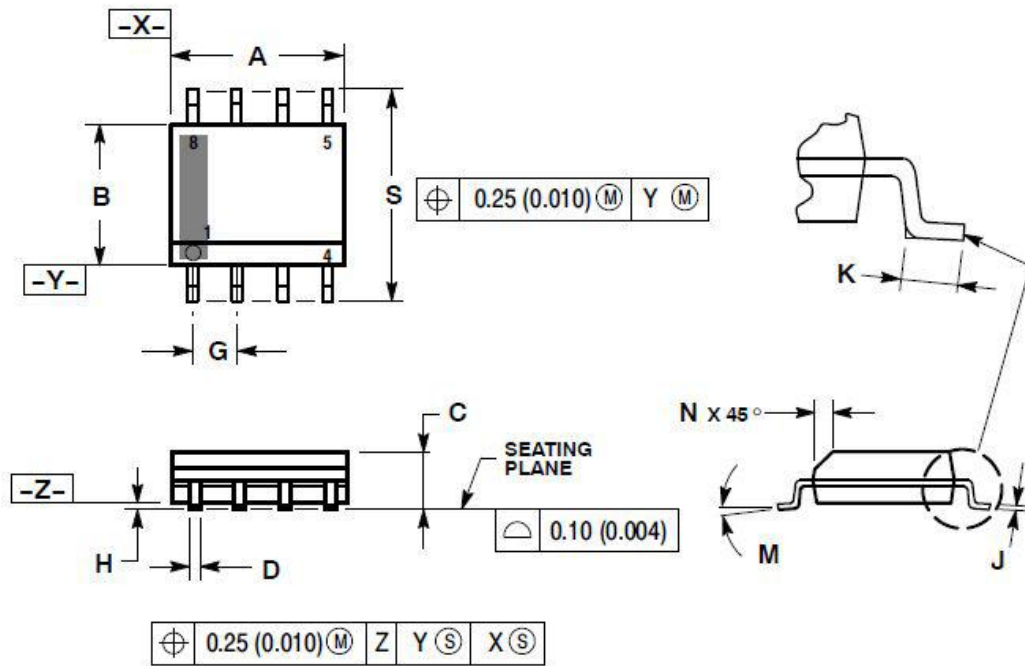

Figure8. Switching wave

Package Information

SOP-8



SOLDERING FOOTPRINT*

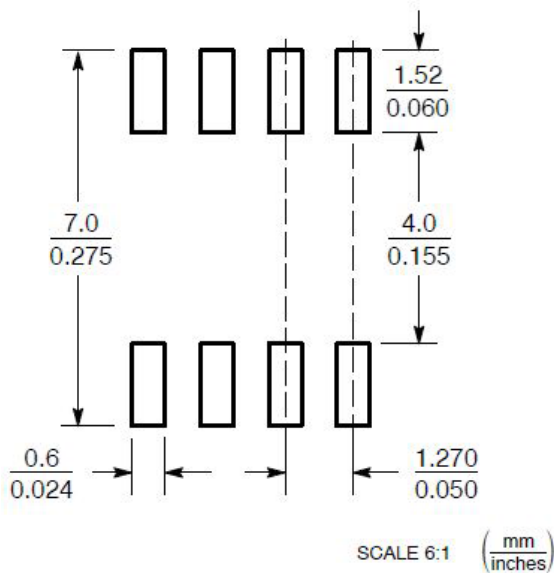

DIM	MILLIMETERS		INCHES	
	MIN	MAX	MIN	MAX
A	4.80	5.00	0.189	0.197
B	3.80	4.00	0.150	0.157
C	1.35	1.75	0.053	0.069
D	0.33	0.51	0.013	0.020
G	1.27 BSC		0.050 BSC	
H	0.10	0.25	0.004	0.010
J	0.19	0.25	0.007	0.010
K	0.40	1.27	0.016	0.050
M	0°	8°	0°	8°
N	0.25	0.50	0.010	0.020
S	5.80	6.20	0.228	0.244