

isc Silicon NPN Power Transistor
3DD5606
DESCRIPTION

- High breakdown voltage
- High switching speed
- High current capability
- Minimum Lot-to-Lot variations for robust device performance and reliable operation

APPLICATIONS

- Energy-saving light
- Electronic ballasts
- High frequency switching power supply
- High frequency power transform

ABSOLUTE MAXIMUM RATINGS(T_a=25°C)

| SYMBOL | PARAMETER | VALUE | UNIT |
|------------------|---|---------|------|
| V _{CEV} | Collector-Emitter Voltage | 1600 | V |
| V _{CEO} | Collector-Emitter Voltage | 800 | V |
| V _{EBO} | Emitter-Base Voltage | 9 | V |
| I _c | Collector Current-Continuous | 6 | A |
| I _{CM} | Collector Current-peak | 10 | A |
| I _B | Base Current | 3 | A |
| P _C | Collector Power Dissipation T _C =25°C | 60 | W |
| T _i | Junction Temperature | 150 | °C |
| T _{stg} | Storage Temperature Range | -55~150 | °C |

THERMAL CHARACTERISTICS

| SYMBOL | PARAMETER | MAX | UNIT |
|---------------------|--------------------------------------|------|------|
| R _{th j-c} | Thermal Resistance, Junction to Case | 2.08 | °C/W |

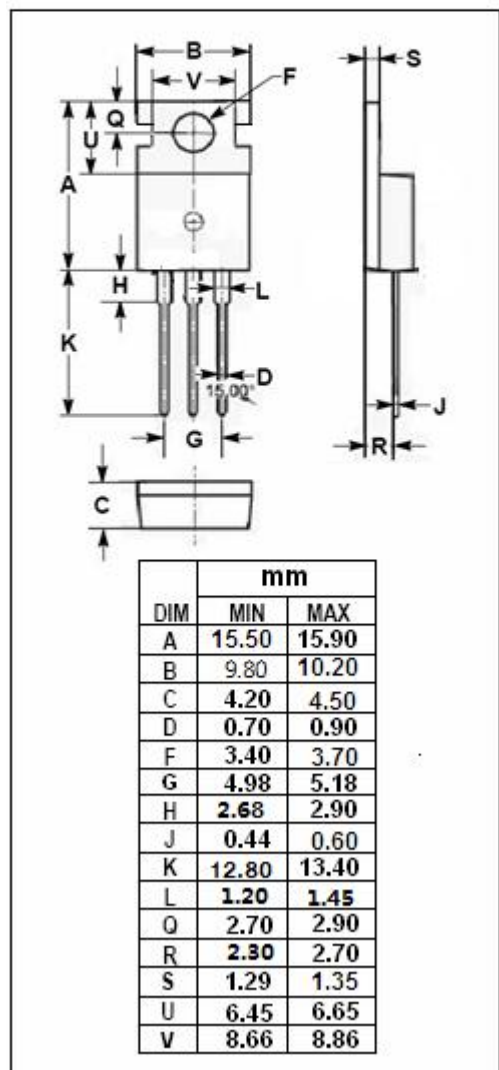
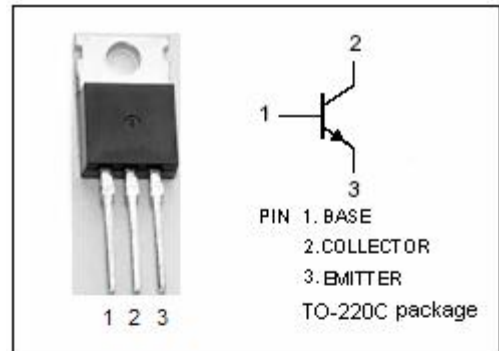

ELECTRICAL CHARACTERISTICS

 T_c =25°C unless otherwise specified

| SYMBOL | PARAMETER | CONDITIONS | MIN | TYP. | MAX | UNIT |
|-----------------------|--------------------------------------|--|-----|------|------|------|
| V _{CEO(SUS)} | Collector-Emitter Sustaining Voltage | I _C = 1mA; I _B = 0 | 800 | | | V |
| V _{CE(sat)} | Collector-Emitter Saturation Voltage | I _C = 2A ;I _B = 0.4A | | | 1.0 | V |
| V _{BE(sat)} | Base-Emitter Saturation Voltage | I _C = 2A ;I _B = 0.4A | | | 1.2 | V |
| I _{CBO} | Collector Cutoff Current | V _{CB} = 1600V; I _E =0 | | | 0.1 | mA |
| I _{EBO} | Emitter Cutoff Current | V _{EB} = 9V; I _C = 0 | | | 0.01 | mA |
| h _{FE-1} | DC Current Gain | I _C = 1A; V _{CE} = 5V | 20 | | | |
| h _{FE-2} | DC Current Gain | I _C = 0.01A; V _{CE} = 5V | 10 | | | |

NOTICE:

ISC reserves the rights to make changes of the content herein the datasheet at any time without notification. The information contained herein is presented only as a guide for the applications of our products.

ISC products are intended for usage in general electronic equipment. The products are not designed for use in equipment which require specialized quality and/or reliability, or in equipment which could have applications in hazardous environments, aerospace industry, or medical field. Please contact us if you intend our products to be used in these special applications.

ISC makes no warranty or guarantee regarding the suitability of its products for any particular purpose, nor does ISC assume any liability arising from the application or use of any products, and specifically disclaims any and all liability, including without limitation special, consequential or incidental damages.