

PRODUCT FEATURES

- Low saturation voltage and positive temperature coefficient
- Fast switching and short tail current
- Free wheeling diodes with fast and soft reverse recovery
- Low switching losses



APPLICATIONS

- Drive inverters with brake system

BRAKE-CHOPPER SECTOR

IGBT-CHOPPER ABSOLUTE MAXIMUM RATINGS

T_C = 25°C unless otherwise specified

Symbol	Parameter/Test Conditions		Values	Unit
V _{CES}	Collector Emitter Voltage	T _J =25°C	1200	V
V _{GES}	Gate Emitter Voltage		±20	
I _C	DC Collector Current	T _C =25°C	105	A
		T _C =80°C	75	
I _{CM}	Repetitive Peak Collector Current	tp=1ms	150	
P _{tot}	Power Dissipation Per IGBT		348	W

Diode ABSOLUTE MAXIMUM RATINGS

T_C = 25°C unless otherwise specified

Symbol	Parameter/Test Conditions		Values	Unit
V _{RRM}	Repetitive Reverse Voltage	T _J =25°C	1200	V
I _{F(AV)}	Average Forward Current	T _C =25°C	75	A
I _{FRM}	Repetitive Peak Forward Current	tp=1ms	150	
I ² t		T _J =125°C, t=10ms, V _R =0V	1150	A ² S

**BRAKE-CHOPPER SECTOR
IGBT-CHOPPER ELECTRICAL CHARACTERISTICS**
 $T_C=25^{\circ}\text{C}$ unless otherwise specified

Symbol	Parameter/Test Conditions		Min.	Typ.	Max.	Unit	
$V_{GE(th)}$	Gate Emitter Threshold Voltage	$V_{CE}=V_{GE}, I_C=3\text{mA}$	5.0	5.8	6.5	V	
$V_{CE(sat)}$	Collector Emitter Saturation Voltage	$I_C=75\text{A}, V_{GE}=15\text{V}, T_J=25^{\circ}\text{C}$		1.7	2.15		
		$I_C=75\text{A}, V_{GE}=15\text{V}, T_J=125^{\circ}\text{C}$		1.9			
I_{CES}	Collector Leakage Current	$V_{CE}=1200\text{V}, V_{GE}=0\text{V}, T_J=25^{\circ}\text{C}$			1	mA	
		$V_{CE}=1200\text{V}, V_{GE}=0\text{V}, T_J=125^{\circ}\text{C}$			10	mA	
I_{GES}	Gate Leakage Current	$V_{CE}=0\text{V}, V_{GE}=\pm 15\text{V}, T_J=25^{\circ}\text{C}$	-400		400	nA	
R_{gint}	Integrated Gate Resistor			10		Ω	
Q_g	Gate Charge	$V_{CE}=600\text{V}, I_C=75\text{A}, V_{GE}=\pm 15\text{V}$		0.7		μC	
C_{ies}	Input Capacitance	$V_{CE}=25\text{V}, V_{GE}=0\text{V}, f=1\text{MHz}$		5.3		nF	
C_{res}	Reverse Transfer Capacitance				200		pF
$t_{d(on)}$	Turn on Delay Time	$V_{CC}=600\text{V}, I_C=75\text{A}$ $R_G=4.7\Omega,$ $V_{GE}=\pm 15\text{V},$ Inductive Load	$T_J=25^{\circ}\text{C}$		260		ns
			$T_J=125^{\circ}\text{C}$		290		ns
t_r	Rise Time	Inductive Load	$T_J=25^{\circ}\text{C}$		30		ns
			$T_J=125^{\circ}\text{C}$		50		ns
$t_{d(off)}$	Turn off Delay Time	$V_{CC}=600\text{V}, I_C=75\text{A}$ $R_G=4.7\Omega,$ $V_{GE}=\pm 15\text{V},$ Inductive Load	$T_J=25^{\circ}\text{C}$		420		ns
			$T_J=125^{\circ}\text{C}$		520		ns
t_f	Fall Time	Inductive Load	$T_J=25^{\circ}\text{C}$		70		ns
			$T_J=125^{\circ}\text{C}$		90		ns
E_{on}	Turn on Energy	$V_{CC}=600\text{V}, I_C=75\text{A}$ $R_G=4.7\Omega,$ $V_{GE}=\pm 15\text{V},$ Inductive Load	$T_J=25^{\circ}\text{C}$		6.6		mJ
			$T_J=125^{\circ}\text{C}$		9.4		mJ
E_{off}	Turn off Energy	Inductive Load	$T_J=25^{\circ}\text{C}$		6.8		mJ
			$T_J=125^{\circ}\text{C}$		8.0		mJ
I_{sc}	Short Circuit Current	$tpsc \leq 10\mu\text{S}, V_{GE}=15\text{V}$ $T_J=125^{\circ}\text{C}, V_{CC}=900\text{V}$		300		A	
R_{thJC}	Junction to Case Thermal Resistance (Per IGBT)				0.36	K /W	

Diode ELECTRICAL CHARACTERISTICS
 $T_C=25^{\circ}\text{C}$ unless otherwise specified

Symbol	Parameter/Test Conditions		Min.	Typ.	Max.	Unit
V_F	Forward Voltage	$I_F=75\text{A}, V_{GE}=0\text{V}, T_J=25^{\circ}\text{C}$		1.65	2.15	V
		$I_F=75\text{A}, V_{GE}=0\text{V}, T_J=125^{\circ}\text{C}$		1.65		
t_{rr}	Reverse Recovery Time	$I_F=75\text{A}, V_R=600\text{V}$		300		ns
I_{RRM}	Max. Reverse Recovery Current	$di_F/dt=-2000\text{A}/\mu\text{s}$		83		A
Q_{RR}	Reverse Recovery Charge	$T_J=125^{\circ}\text{C}$		13		μC
E_{rec}	Reverse Recovery Energy			6.5		mJ
R_{thJCD}	Junction to Case Thermal Resistance (Per Diode)				0.6	K /W

Diode-RECTIFIER

ABSOLUTE MAXIMUM RATINGS

$T_C=25^\circ\text{C}$ unless otherwise specified

Symbol	Parameter/Test Conditions		Values	Unit
V_{RRM}	Repetitive Reverse Voltage	$T_J=25^\circ\text{C}$	1600	V
I_D	Output Current(D.C.)	Three phase, half wave, $T_C=95^\circ\text{C}$	150	A
I_{FSM}	Non Repetitive Surge Forward Current	$T_J=45^\circ\text{C}$, $t=10\text{ms}$, 50Hz	910	
		$T_J=45^\circ\text{C}$, $t=8.3\text{ms}$, 60Hz	1000	
I^2t		$T_J=45^\circ\text{C}$, $t=10\text{ms}$, 50Hz	4140	A ² S
		$T_J=45^\circ\text{C}$, $t=8.3\text{ms}$, 60Hz	4150	

Diode-RECTIFIER

ELECTRICAL CHARACTERISTICS

$T_C=25^\circ\text{C}$ unless otherwise specified

Symbol	Parameter/Test Conditions		Min.	Typ.	Max.	Unit
V_F	Forward Voltage	$I_F=75\text{A}$, $T_J=25^\circ\text{C}$		1.15	1.35	V
		$I_F=75\text{A}$, $T_J=125^\circ\text{C}$		1.1		V
I_R	Reverse Leakage Current	$V_R=1600\text{V}$, $T_J=25^\circ\text{C}$			50	μA
		$V_R=1600\text{V}$, $T_J=125^\circ\text{C}$			1	mA
V_{TO}	For power-loss calculations only, $T_J=125^\circ\text{C}$				0.87	V
r_T					6.0	m Ω
R_{thJCD}	Junction to Case Thermal Resistance (Per Diode)				0.55	K/W

NTC CHARACTERISTICS

$T_C=25^\circ\text{C}$ unless otherwise specified

Symbol	Parameter/Test Conditions		Min.	Typ.	Max.	Unit
R_{25}	Resistance	$T_C=25^\circ\text{C}$		5		K Ω
$B_{25/50}$	$R_2 = R_{25} \exp [B_{25/50}(1/T_2 - 1/(298.15 \text{ K}))]$			3375		K

MODULE CHARACTERISTICS

$T_C=25^\circ\text{C}$ unless otherwise specified

Symbol	Parameter/Test Conditions		Values	Unit
T_{Jmax}	Max. Junction Temperature		150	$^\circ\text{C}$
T_{Jop}	Operating Temperature		-40~125	
T_{stg}	Storage Temperature		-40~125	
V_{isol}	Isolation Breakdown Voltage	AC, 50Hz(R.M.S), $t=1\text{minute}$	3000	V
Md	Mounting Torque	Recommended (M5)	2.5~5	Nm
Weight			180	g

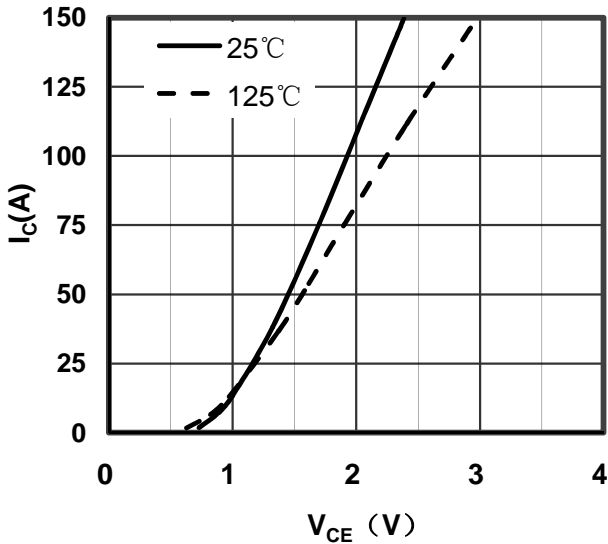

Figure 1. Typical Output Characteristics IGBT

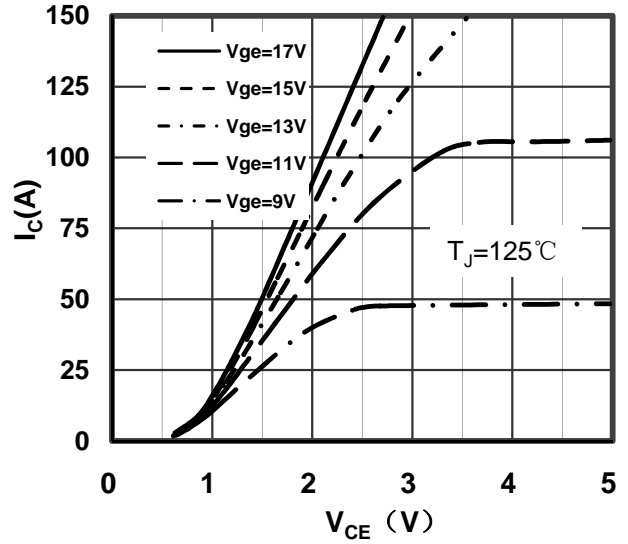

Figure 2. Typical Output Characteristics IGBT

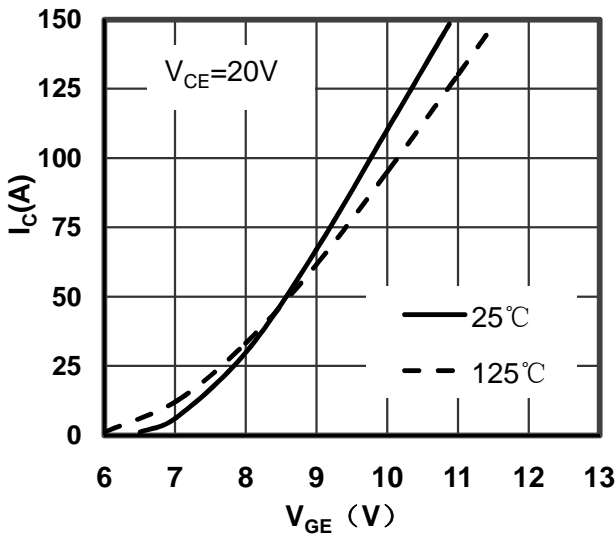

Figure 3. Typical Transfer characteristics IGBT

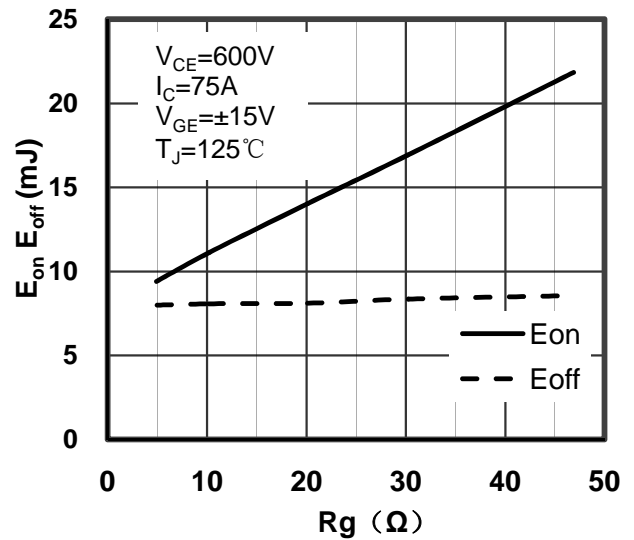

Figure 4. Switching Energy vs Gate Resistor IGBT

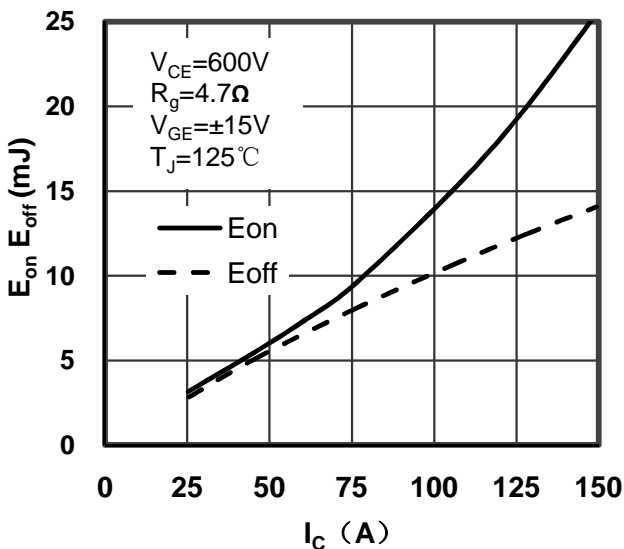

Figure 5. Switching Energy vs Collector Current IGBT

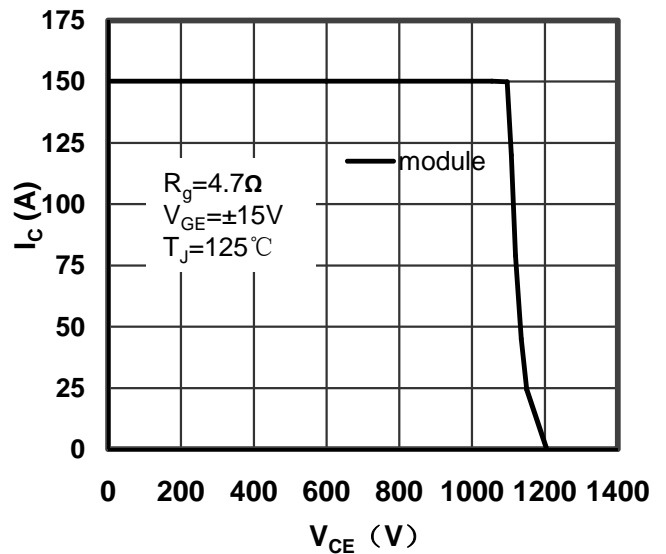

Figure 6. Reverse Biased Safe Operating Area IGBT

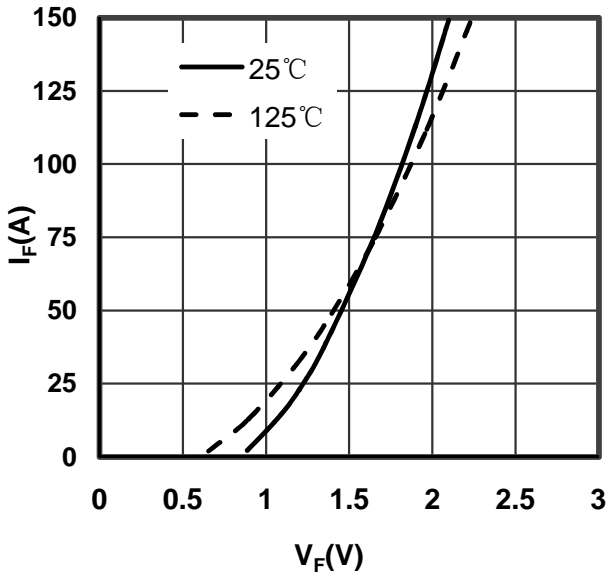

Figure 7. Diode Forward Characteristics
Diode

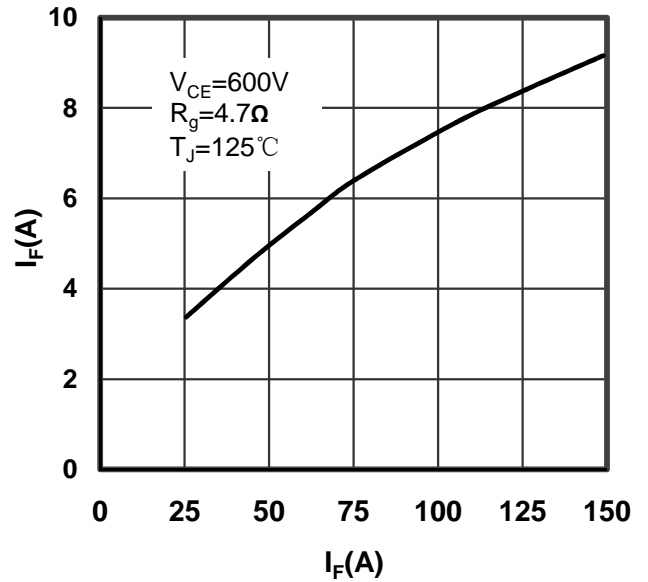

Figure 8. Switching Energy vs Forward Current
Diode

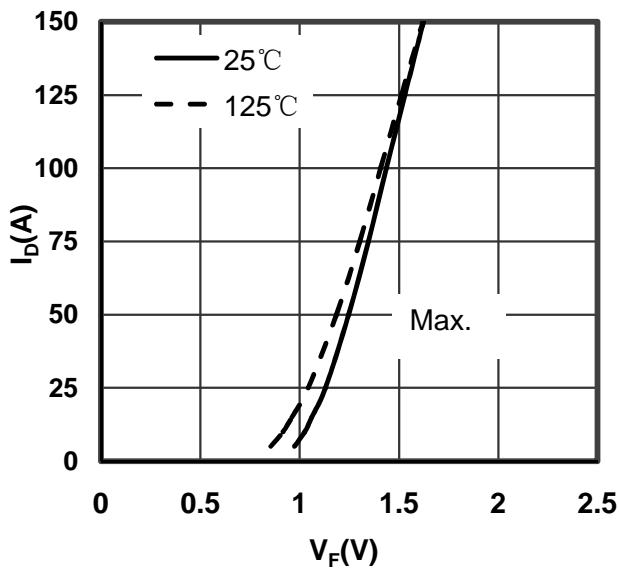

Figure 9. Forward Voltage Drop vs Output Current

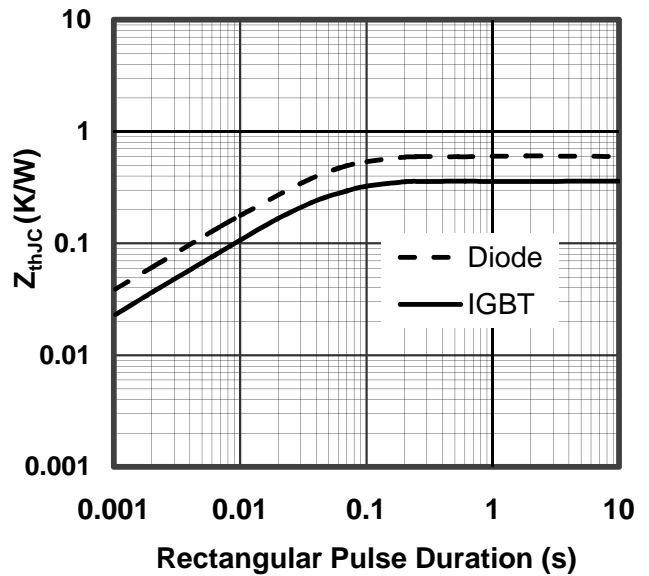

Figure 10. Transient Thermal Impedance of
Diode and IGBT

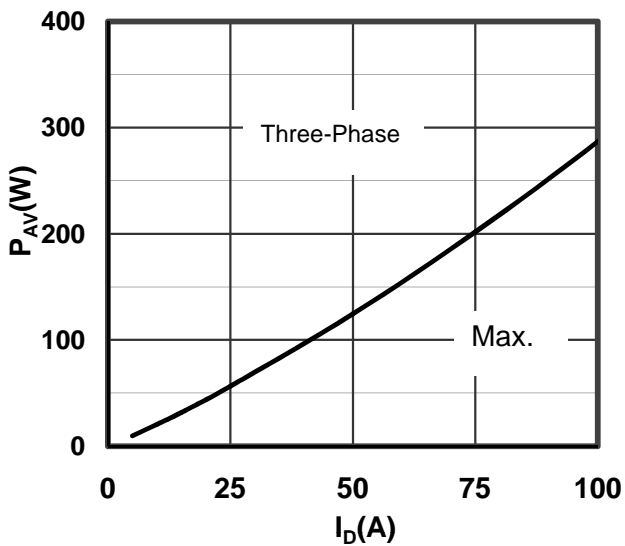

Figure 11. Power dissipation vs Output Current

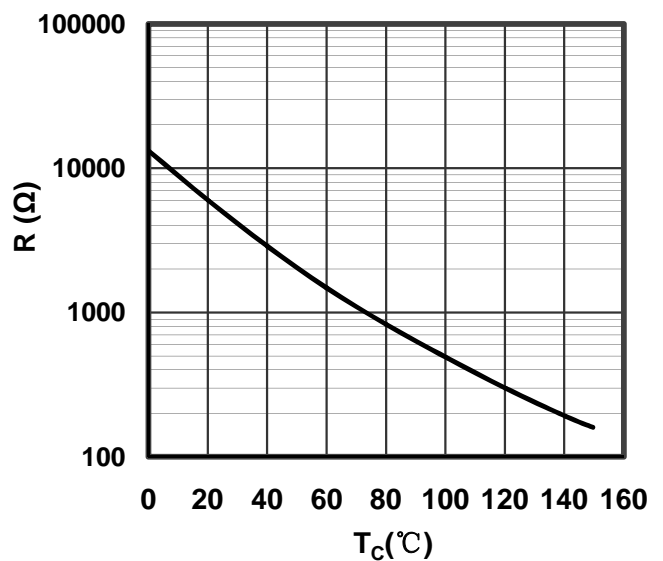

Figure 12. NTC Characteristics

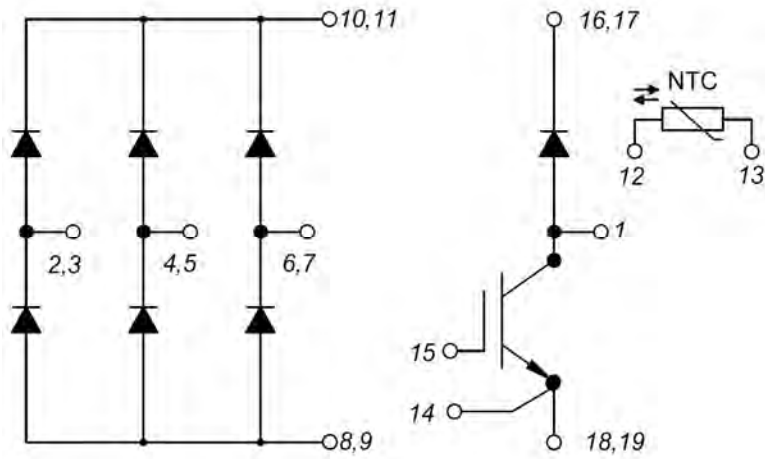
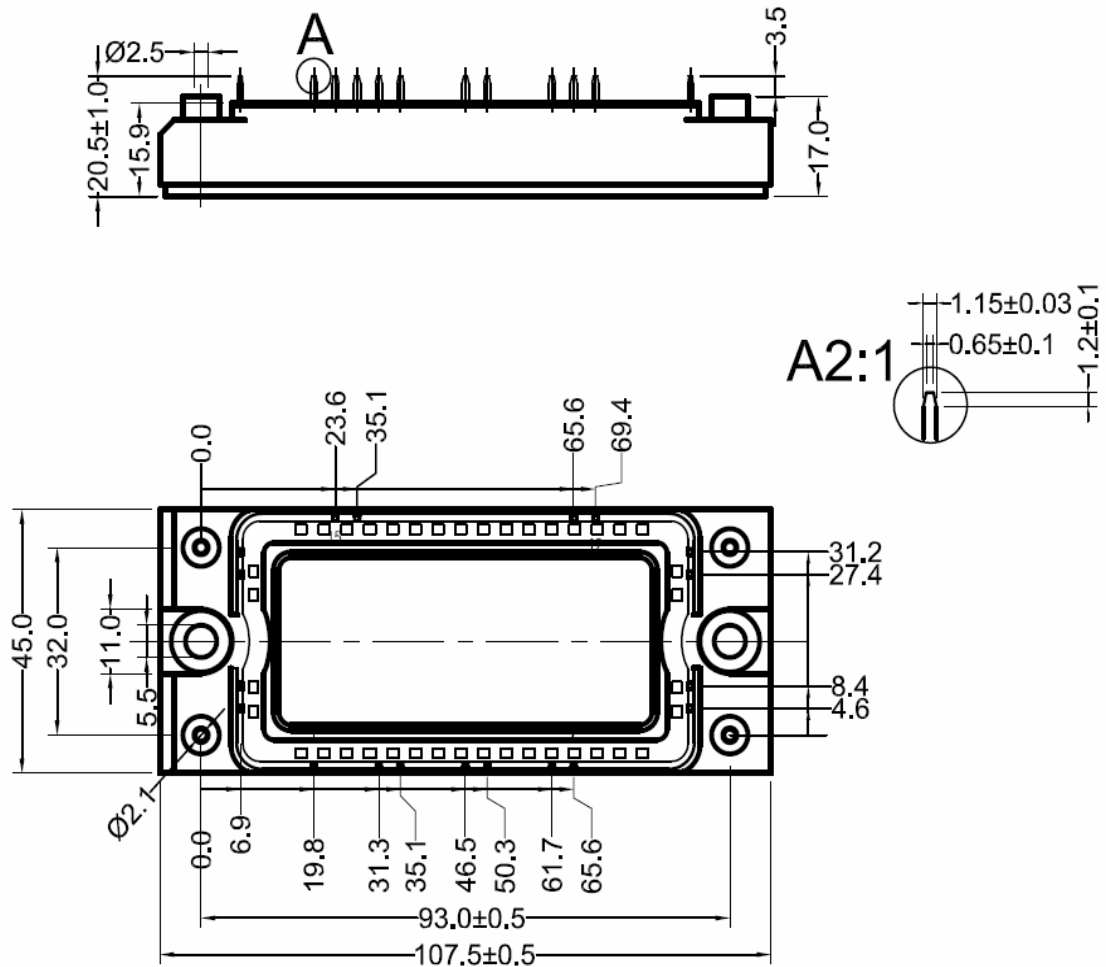

Figure 13. Circuit Diagram



Dimensions in (mm)
Figure 14. Package Outline