

# W957D8MFYA / W957A8MFYA



## 1. FEATURES

<ul style="list-style-type: none"><li>• Interface: HyperBus</li><li>• Power supply: 1.7V~2.0V or 2.7V~3.6V</li><li>• Maximum clock rate: 200MHz</li><li>• Double-Data Rate (DDR) Up to 400 MT/s</li><li>• Clock:<ul style="list-style-type: none"><li>– Single ended clock (CK)</li><li>– Differential clock (CK/CK#)</li></ul></li><li>• Chip Select (CS#)</li><li>• 8-bit data bus (DQ[7:0])</li><li>• Hardware reset (RESET#)</li><li>• Read-Write Data Strobe (RWDS)<ul style="list-style-type: none"><li>– Bidirectional Data Strobe / Mask</li><li>– Output at the start of all transactions to indicate refresh latency</li><li>– Output during read transactions as Read Data Strobe</li><li>– Input during write transactions as Write Data Mask</li></ul></li></ul>	<b>Performance and Power</b> <ul style="list-style-type: none"><li>• Configurable output drive strength</li><li>• Power Saving Modes<ul style="list-style-type: none"><li>– Hybrid Sleep Mode</li><li>– Deep Power Down</li></ul></li><li>• Configurable Burst Characteristics<ul style="list-style-type: none"><li>– Linear burst</li><li>– Wrapped burst lengths:<ul style="list-style-type: none"><li>– 16 bytes (8 clocks)</li><li>– 32 bytes (16 clocks)</li><li>– 64 bytes (32 clocks)</li><li>– 128 bytes (64 clocks)</li></ul></li><li>– Hybrid burst - one wrapped burst followed by linear burst</li></ul></li><li>• Array Refresh Modes<ul style="list-style-type: none"><li>– Full Array Refresh</li><li>– Partial Array Refresh</li></ul></li><li>• Support package: Dual-Die-Package (DDP), two of 64M bit chip sealed in one 24 balls TFBGA package</li><li>• Operating temperature range: -40°C ≤ TCASE ≤ 85°C</li></ul>
---	--

## 2. ORDER INFORMATION

Part Number	VCC/VCCQ	I/O Width	Package	Interface	Others
W957D8MFYA5I	1.8V	8	24 balls TFBGA, DDP	HyperBus	200MHz, -40°C~85°C
W957A8MFYA5I	3.0V	8	24 balls TFBGA, DDP	HyperBus	200MHz, -40°C~85°C
W957A8MFYA6I	3.0V	8	24 balls TFBGA, DDP	HyperBus	166MHz, -40°C~85°C

The above information is the exclusive intellectual property of Winbond Electronics and shall not be disclosed, distributed or reproduced without permission from Winbond.

Publication Release Date: Sep. 03, 2020  
Revision: A01-001



3. BALL ASSIGNMENT

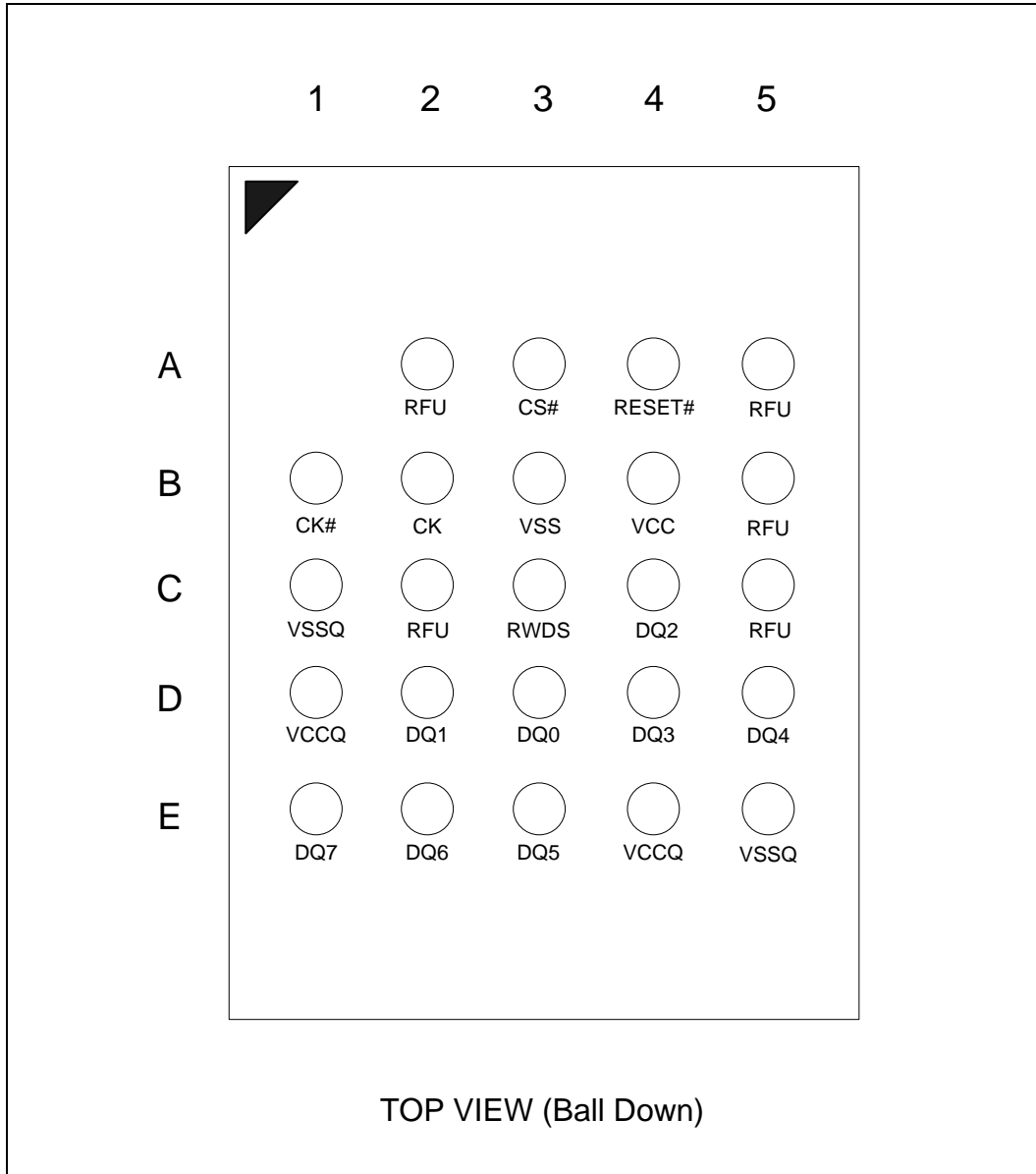

24 Balls TFBGA, 5x5-1 Ball Footprint, Top View

The above information is the exclusive intellectual property of Winbond Electronics and shall not be disclosed, distributed or reproduced without permission from Winbond.

Publication Release Date: Sep. 03, 2020  
Revision: A01-001



#### 4. BALL DESCRIPTIONS

Symbol	Type	Description
CS#	Input	<b>Chip Select:</b> Bus transactions are initiated with a High to Low transition. Bus transactions are terminated with a Low to High transition. The master device has a separate CS# for each slave.
CK, CK#	Input	<b>Differential Clock:</b> Command, address, and data information is output with respect to the crossing of the CK and CK# signals. <b>Single Ended Clock:</b> CK# is not used, only a single ended CK is used. The clock is not required to be free-running.
DQ[7:0]	Input / Output	<b>Data Input / Output:</b> Command, Address, and Data information is transferred on these signals during Read and Write transactions.
RWDS	Input / Output	<b>Read Write Data Strobe:</b> During the Command/Address portion of all bus transactions RWDS is a slave output and indicates whether additional initial latency is required. Slave output during read data transfer, data is edge aligned with RWDS. Slave input during data transfer in write transactions to function as a data mask. (High = additional latency, for DDP package, RWDS will not be allowed to drive Low).
RESET#	Input, Internal Pull-up	<b>Hardware Reset:</b> When Low the slave device will self-initialize and return to the Standby state. RWDS and DQ[7:0] are placed into the High-Z state when RESET# is Low. The slave RESET# input includes a weak pull-up, if RESET# is left unconnected it will be pulled up to the High state. <b>Note:</b> The RESET# pin is maximum 4V tolerant.
Vcc	Power Supply	<b>Vcc Power Supply:</b> For supplying input buffer of CK/CK#, CS#, RESET#, DQ[7:0] and RWDS, internal circuitry and memory array.
Vccq	Power Supply	<b>Vccq Power Supply:</b> For supplying output buffer of DQ[7:0] and RWDS.
Vss	Power Supply	<b>Vss Ground:</b> Ground of Vcc.
Vssq	Power Supply	<b>Vssq Ground:</b> Ground of Vccq.
RFU	No Connect	<b>Reserved for Future Use:</b> May or may not be connected internally, the signal/ball location should be left unconnected and unused by PCB routing channel for future compatibility. The signal/ball may be used by a signal in the future.

*The above information is the exclusive intellectual property of Winbond Electronics and shall not be disclosed, distributed or reproduced without permission from Winbond.*

*Publication Release Date: Sep. 03, 2020  
Revision: A01-001*



5. BLOCK DIAGRAM

5.1 Function Block Diagram (Single Die)

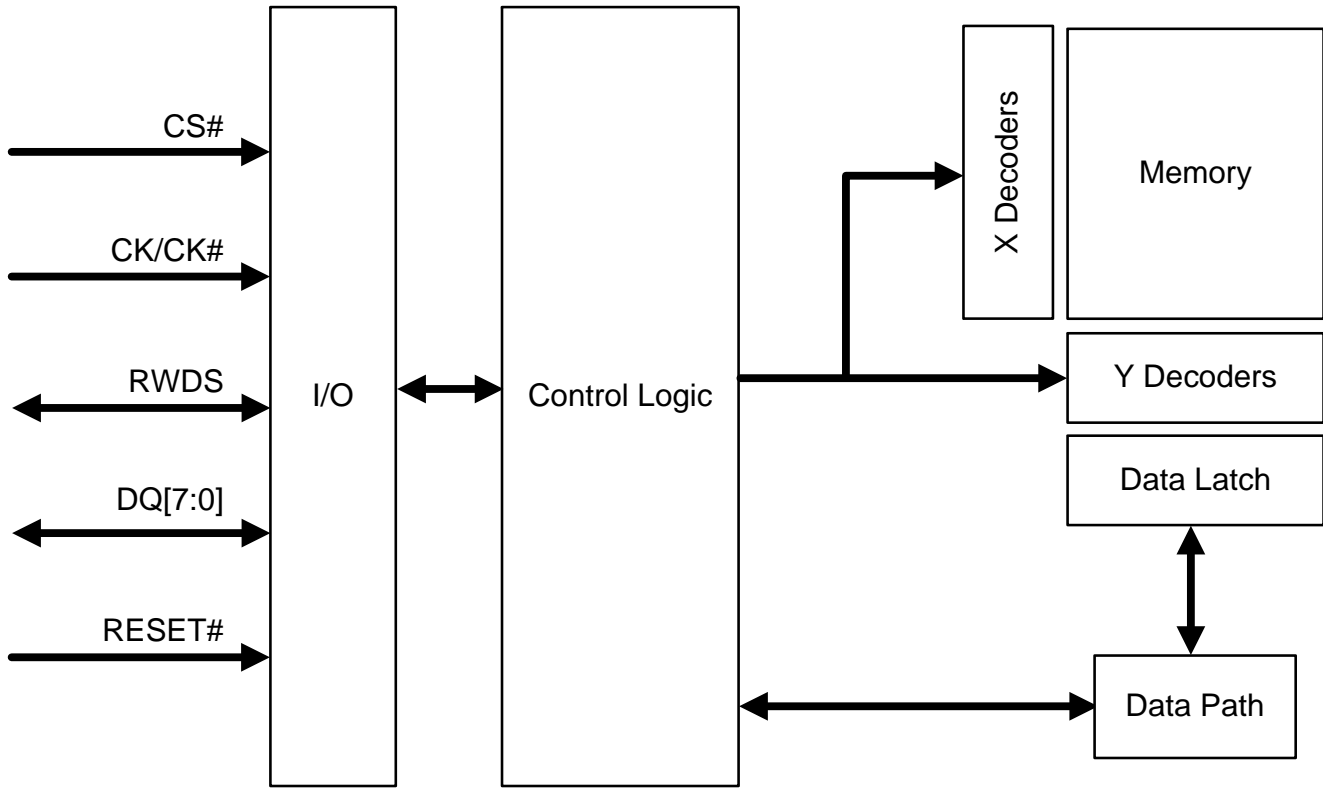

The above information is the exclusive intellectual property of Winbond Electronics and shall not be disclosed, distributed or reproduced without permission from Winbond.

Publication Release Date: Sep. 03, 2020  
Revision: A01-001



5.2 Package Block Diagram (DDP)

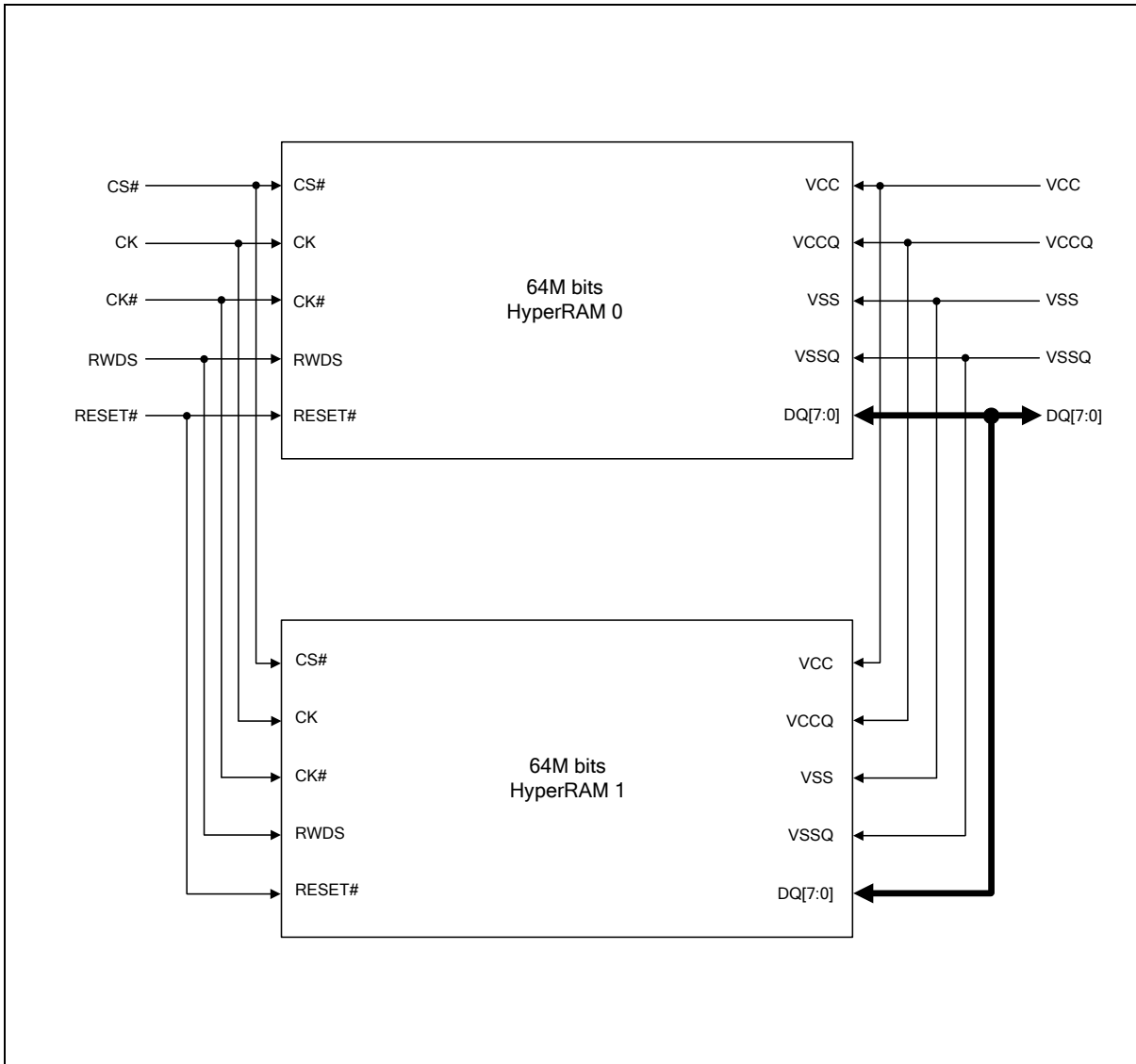

The above information is the exclusive intellectual property of Winbond Electronics and shall not be disclosed, distributed or reproduced without permission from Winbond.

Publication Release Date: Sep. 03, 2020  
Revision: A01-001



## 6. FUNCTIONAL DESCRIPTION

### 6.1 HyperBus Interface

HyperBus is a low signal count, Double Data Rate (DDR) interface, that achieves high speed read and write throughput. The DDR protocol transfers two data bytes per clock cycle on the DQ input/output signals. A read or write transaction on HyperBus consists of a series of 16-bit wide, one clock cycle data transfers at the internal HyperRAM array with two corresponding 8-bit wide, one-half-clock-cycle data transfers on the DQ signals. All inputs and outputs are LV-CMOS compatible.

Command, address, and data information is transferred over the eight HyperBus DQ[7:0] signals. The clock (CK#, CK) is used for information capture by a HyperBus slave device when receiving command, address, or data on the DQ signals. Command or Address values are center aligned with clock transitions.

Every transaction begins with the assertion of CS# and Command-Address (CA) signals, followed by the start of clock transitions to transfer six CA bytes, followed by initial access latency and either read or write data transfers, until CS# is de-asserted.

Read and write transactions require two clock cycles to define the target row address and burst type, then an initial access latency of  $t_{ACC}$ . During the CA part of a transaction, the memory will indicate whether an additional latency for a required refresh time ( $tr_{FH}$ ) is added to the initial latency; by driving the RWDS signal to the High state. During the CA period the third clock cycle will specify the target word address within the target row. During a read (or write) transaction, after the initial data value has been output (or input), additional data can be read from (or written to) the row on subsequent clock cycles in either a wrapped or linear sequenced. When configured in linear burst mode, the device will automatically fetch the next sequential row from the memory array to support a continuous linear burst. Simultaneously accessing the next row in the array while the read or write data transfer is in progress, allows for a linear sequential burst operation that can provide a sustained data rate of 400 MB/s (1 byte (8 bit data bus) \* 2 (data clock edges) \* 200 MHz = 400 MB/s). Once linear burst reaches the last address of 64Mb of the accessed die, then the addressing will go back to minimum address of the die.

*The above information is the exclusive intellectual property of Winbond Electronics and shall not be disclosed, distributed or reproduced without permission from Winbond.*

*Publication Release Date: Sep. 03, 2020  
Revision: A01-001*



The Read/Write Data Strobe (RWDS) is a bidirectional signal that indicates:

- When data will start to transfer from a HyperRAM device to the master device in read transactions (initial read latency)
- When data is being transferred from a HyperRAM device to the master device during read transactions (as a source synchronous read data strobe)
- When data may start to transfer from the master device to a HyperRAM device in write transactions (initial write latency)
- Data masking during write data transfers

During the CA transfer portion of a read or write transaction, RWDS acts as an output from a HyperRAM device to indicate whether additional initial access latency is needed in the transaction.

During read data transfers, RWDS is a read data strobe with data values edge aligned with the transitions of RWDS.

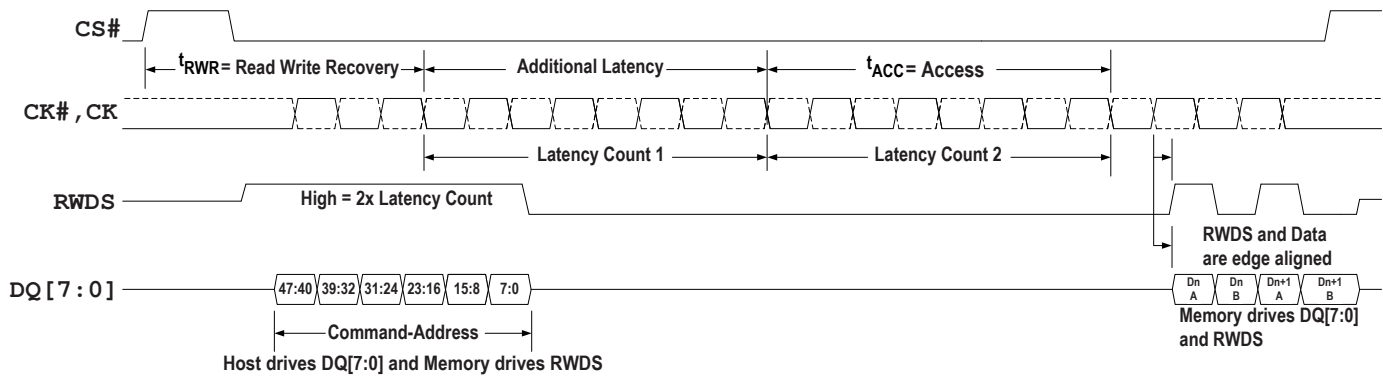

**Figure 1 - Read Transaction, Additional Latency Count**

During write data transfers, RWDS indicates whether each data byte transfer is masked with RWDS High (invalid and prevented from changing the byte location in a memory) or not masked with RWDS Low (valid and written to a memory). Data masking may be used by the host to byte align write data within a memory or to enable merging of multiple non-word aligned writes in a single burst write. During write transactions, data is center aligned with clock transitions.

*The above information is the exclusive intellectual property of Winbond Electronics and shall not be disclosed, distributed or reproduced without permission from Winbond.*

Publication Release Date: Sep. 03, 2020  
Revision: A01-001



Read and write transactions are burst oriented, transferring the next sequential word during each clock cycle. Each individual read or write transaction can use either a wrapped or linear burst sequence.

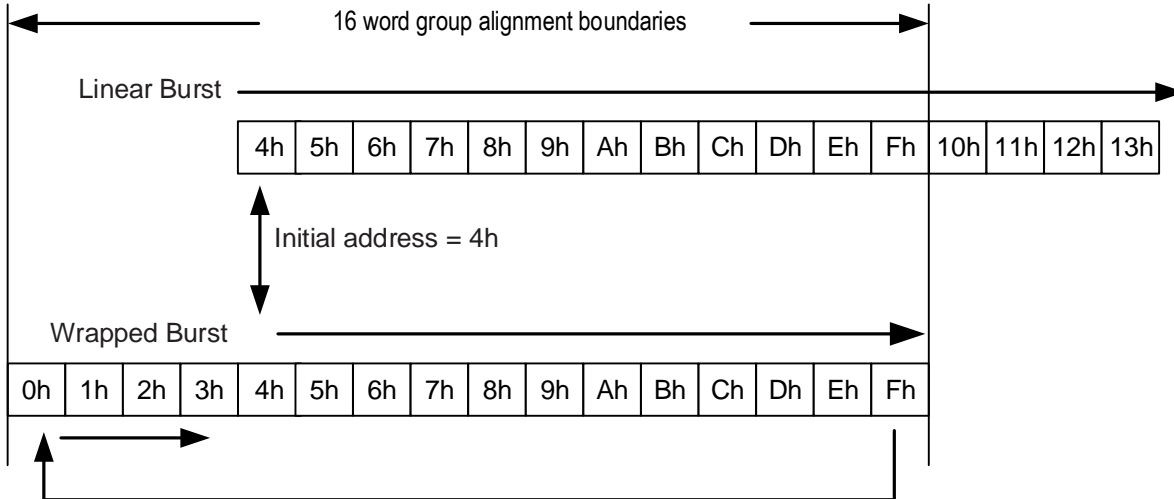

Figure 2 - Linear Versus Wrapped Burst Sequence

During wrapped transactions, accesses start at a selected location and continue to the end of a configured word group aligned boundary, then wrap to the beginning location in the group, then continue back to the starting location. Wrapped bursts are generally used for critical word first cache line fill read transactions. During linear transactions, accesses start at a selected location and continue in a sequential manner until the transaction is terminated when CS# returns High. Linear transactions are generally used for large contiguous data transfers such as graphic images. Since each transaction command selects the type of burst sequence for that transaction, wrapped and linear bursts transactions can be dynamically intermixed as needed.

*The above information is the exclusive intellectual property of Winbond Electronics and shall not be disclosed, distributed or reproduced without permission from Winbond.*

*Publication Release Date: Sep. 03, 2020  
Revision: A01-001*



## 7. HYPERBUS TRANSACTION DETAILS

### 7.1 Command/Address Bit Assignments

All HyperRAM bus transactions can be classified as either read or write. A bus transaction is started with CS# going Low with clock in idle state (CK=Low and CK#=High). The first three clock cycles transfer three words of Command/Address (CA0, CA1, CA2) information to define the transaction characteristics. The Command/Address words are presented with DDR timing, using the first six clock edges. The following characteristics are defined by the Command/Address information:

- Read or Write transaction
- Address Space: memory array space or register space
  - Register space is used to access Device Identification (ID) registers and Configuration Registers (CR) that identify the device characteristics and determine the slave specific behavior of read and write transfers on the HyperBus interface.
- Whether a transaction will use a linear or wrapped burst sequence
- The target row (and half-page) address (upper order address)
- The target column (word within half-page) address (lower order address)

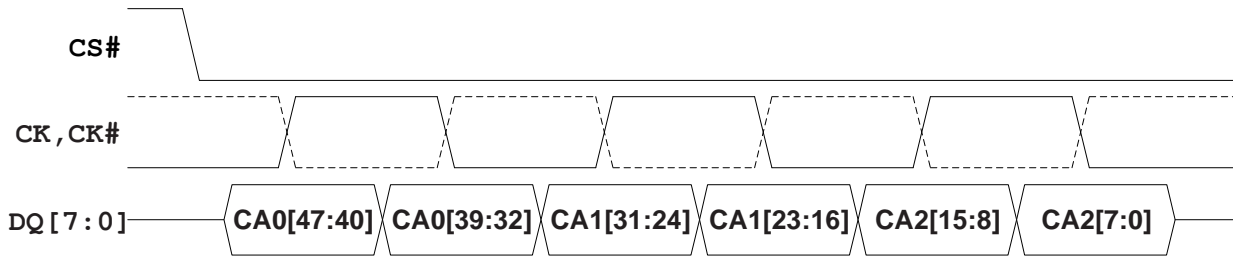

Figure 3 - Command-Address (CA) Sequence

**Notes:**

1. Figure shows the initial three clock cycles of all transactions on the HyperBus.
2. CK# of differential clock is shown as dashed line waveform.
3. CA information is “center aligned” with the clock during both Read and Write transactions.
4. Data bits in each byte are always in high to low order with bit 7 on DQ7 and bit 0 on DQ0.

Table 1 - CA Bit Assignment to DQ Signals

Signal	CA0[47:40]	CA0[39:32]	CA1[31:24]	CA1[23:16]	CA2[15:8]	CA2[7:0]
DQ[7]	CA[47]	CA[39]	CA[31]	CA[23]	CA[15]	CA[7]
DQ[6]	CA[46]	CA[38]	CA[30]	CA[22]	CA[14]	CA[6]
DQ[5]	CA[45]	CA[37]	CA[29]	CA[21]	CA[13]	CA[5]
DQ[4]	CA[44]	CA[36]	CA[28]	CA[20]	CA[12]	CA[4]
DQ[3]	CA[43]	CA[35]	CA[27]	CA[19]	CA[11]	CA[3]
DQ[2]	CA[42]	CA[34]	CA[26]	CA[18]	CA[10]	CA[2]
DQ[1]	CA[41]	CA[33]	CA[25]	CA[17]	CA[9]	CA[1]
DQ[0]	CA[40]	CA[32]	CA[24]	CA[16]	CA[8]	CA[0]

The above information is the exclusive intellectual property of Winbond Electronics and shall not be disclosed, distributed or reproduced without permission from Winbond.

Publication Release Date: Sep. 03, 2020  
Revision: A01-001



Table 2 - Command/Address Bit Assignments

CA Bit#	Bit Name	Bit Function
47	R/W#	Identifies the transaction as a read or write. R/W#=1 indicates a Read transaction R/W#=0 indicates a Write transaction
46	Address Space (AS)	Indicates whether the read or write transaction accesses the memory or register space. AS=0 indicates memory space AS=1 indicates the register space The register space is used to access device ID and Configuration registers.
45	Burst Type	Indicates whether the burst will be linear or wrapped. Burst Type=0 indicates wrapped burst Burst Type=1 indicates linear burst
44-16	Row & Upper Column Address	Row & Upper Column component of the target address: System word address bits A31-A3 Any upper Row address bits not used by a particular device density should be set to 0 by the host controller master interface. The size of Rows and therefore the address bit boundary between Row and Column address is slave device dependent.
15-3	Reserved	Reserved for future column address expansion. Reserved bits are don't care in current HyperBus devices but should be set to 0 by the host controller master interface for future compatibility.
2-0	Lower Column Address	Lower Column component of the target address: System word address bits A2-A0 selecting the starting word within a half-page.

**Notes:**

- The Column address selects the burst transaction starting word location within a Row. The Column address is split into an upper and lower portion. The upper portion selects an 8-word (16-byte) Half-page and the lower portion selects the word within a Half-page where a read or write transaction burst starts.
- The initial read access time starts when the Row and Upper Column (Half-page) address bits are captured by a slave interface. Continuous linear read burst is enabled by memory devices internally interleaving access to 16 byte half-pages.
- HyperBus protocol address space limit, assuming:
  - 29 Row & Upper Column address bits
  - 3 Lower Column address bits
  - Each address selects a word wide (16 bit = 2 byte) data value
  - 29 + 3 = 32 address bits = 4G addresses supporting 8Gbyte (64Gbit) maximum address space

*The above information is the exclusive intellectual property of Winbond Electronics and shall not be disclosed, distributed or reproduced without permission from Winbond.*

*Publication Release Date: Sep. 03, 2020  
Revision: A01-001*

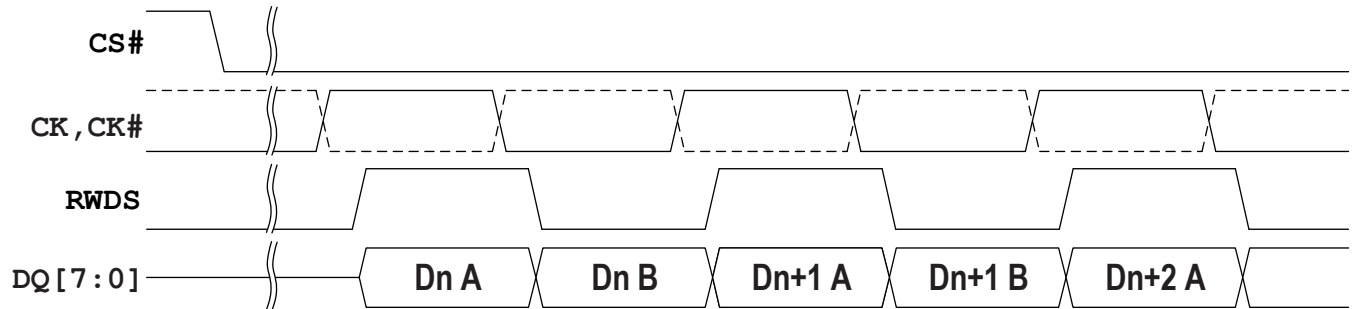

**Figure 4 - Data Placement during a Read Transaction**

**Notes:**

1. Figure shows a portion of a Read transaction on the HyperBus. CK# of differential clock is shown as dashed line waveform.
2. Data is “edge aligned” with the RWDS serving as a read data strobe during read transactions.
3. Data is always transferred in full word increments (word granularity transfers).
4. Word address increments in each clock cycle. Byte A is between RWDS rising and falling edges and is followed by byte B between RWDS falling and rising edges, of each word.
5. Data bits in each byte are always in high to low order with bit 7 on DQ7 and bit 0 on DQ0.

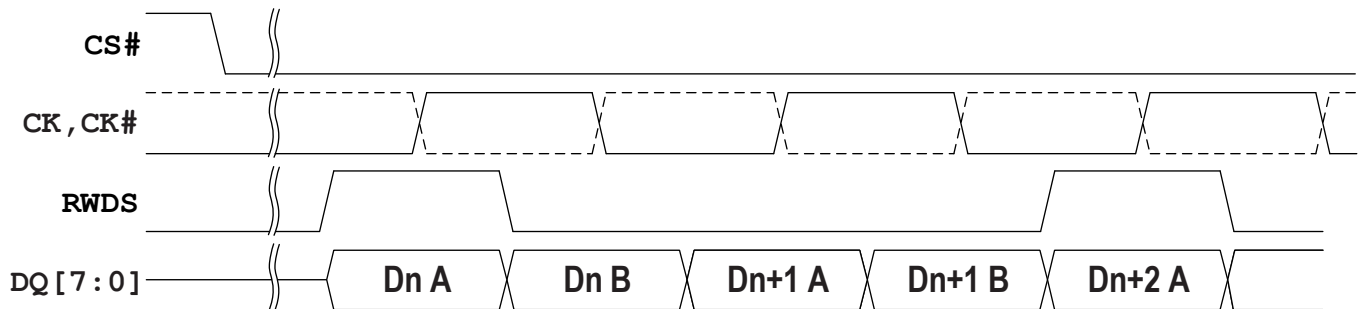

**Figure 5 - Data Placement during a Write Transaction**

**Notes:**

1. Figure shows a portion of a Write transaction on the HyperBus.
2. Data is “center aligned” with the clock during a Write transaction.
3. RWDS functions as a data mask during write data transfers with initial latency. Masking of the first and last byte is shown to illustrate an unaligned 3 byte write of data.
4. RWDS is not driven by the master during write data transfers with zero initial latency. Full data words are always written in this case. RWDS may be driven Low or left High-Z by the slave in this case.

*The above information is the exclusive intellectual property of Winbond Electronics and shall not be disclosed, distributed or reproduced without permission from Winbond.*

*Publication Release Date: Sep. 03, 2020  
Revision: A01-001*



## 7.2 Read Transactions

The HyperBus master begins a transaction by driving CS# Low while clock is idle. The clock then begins toggling while CA words are transferred.

In CA0, CA[47] = 1 indicates that a Read transaction is to be performed. CA[46] = 0 indicates the memory space is being read or CA[46] = 1 indicates the register space is being read. CA[45] indicates the burst type (wrapped or linear). Read transactions can begin the internal array access as soon as the row and upper column address has been presented in CA0 and CA1 (CA[47:16]). CA2 (CA[15:0]) identifies the target Word address within the chosen row.

The HyperBus master then continues clocking for a number of cycles defined by the latency count setting in Configuration Register 0. The initial latency count required for a particular clock frequency is based on RWDS. If RWDS is High during the CA cycles, an additional latency count is inserted. Once these latency clocks have been completed the memory starts to simultaneously transition the Read-Write Data Strobe (RWDS) and output the target data.

New data is output edge aligned with every transition of RWDS. Data will continue to be output as long as the host continues to transition the clock while CS# is Low. However, the HyperRAM device may stop RWDS transitions with RWDS Low, between the deliveries of words, in order to insert latency between words when crossing memory array boundaries.

Wrapped bursts will continue to wrap within the burst length and linear burst will output data in a sequential manner across row boundaries. When a linear burst read reaches the last address in the array, continuing the burst beyond the last address will provide data from the beginning of the address range. Read transfers can be ended at any time by bringing CS# High when the clock is idle.

The clock is not required to be free-running. The clock may remain idle while CS# is High.

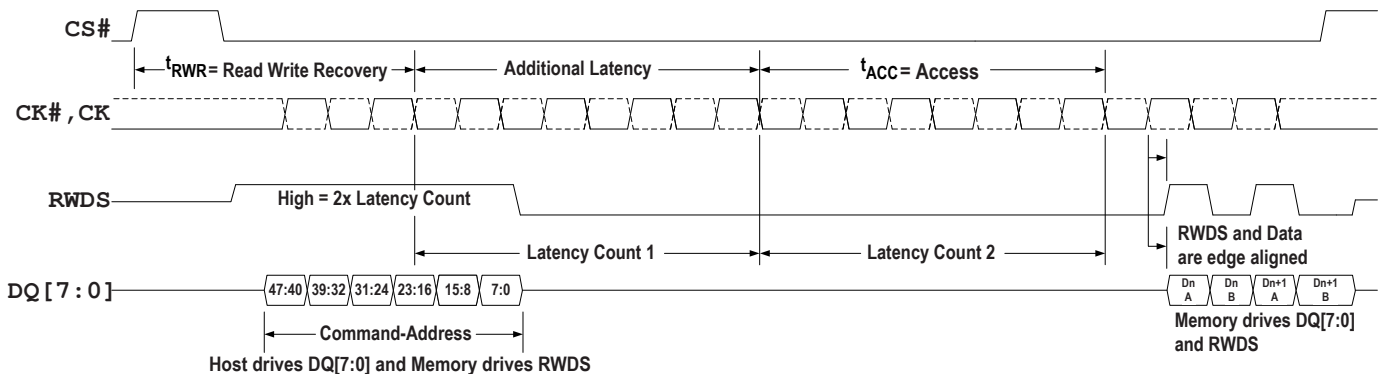

Figure 6 - Read Transaction with Additional Initial Latency

### Notes:

1. Transactions are initiated with CS# falling while CK=Low and CK#=High.
2. CS# must return High before a new transaction is initiated.
3. CK# is the complement of the CK signal. CK# of a differential clock is shown as a dashed line waveform.
4. Read access array starts once CA[23:16] is captured.
5. The read latency is defined by the initial latency value in a configuration register.
6. In this read transaction example the initial latency count was set to four clocks.
7. In this read transaction a RWDS High indication during CA delays output of target data by an additional four clocks.
8. The memory device drives RWDS during read transactions.
9. For register read, the output data Dn A is RG[15:8], Dn B is RG[7:0], Dn+1 A is RG[15:8], Dn+1 B is RG[7:0].

*The above information is the exclusive intellectual property of Winbond Electronics and shall not be disclosed, distributed or reproduced without permission from Winbond.*

Publication Release Date: Sep. 03, 2020  
Revision: A01-001



### 7.3 Write Transactions (Memory Array Write)

The HyperBus master begins a transaction by driving CS# Low while clock is idle. Then the clock begins toggling while CA words are transferred.

In CA0, CA[47] = 0 indicates that a Write transaction is to be performed. CA[46] = 0 indicates the memory space is being written. CA[45] indicates the burst type (wrapped or linear). Write transactions can begin the internal array access as soon as the row and upper column address has been presented in CA0 and CA1 (CA[47:16]). CA2 (CA[15:0]) identifies the target word address within the chosen row.

The HyperBus master then continues clocking for a number of cycles defined by the latency count setting in configuration register 0. The initial latency count required for a particular clock frequency is based on RWDS. If RWDS is High during the CA cycles, an additional latency count is inserted.

Once these latency clocks have been completed the HyperBus master starts to output the target data. Write data is center aligned with the clock edges. The first byte of data in each word is captured by the memory on the rising edge of CK and the second byte is captured on the falling edge of CK.

During the CA clock cycles, RWDS is driven by the memory.

During the write data transfers, RWDS is driven by the host master interface as a data mask. When data is being written and RWDS is High the byte will be masked and the array will not be altered. When data is being written and RWDS is Low the data will be placed into the array. Because the master is driving RWDS during write data transfers, neither the master nor the HyperRAM device is able to indicate a need for latency within the data transfer portion of a write transaction. The acceptable write data burst length setting is also shown in configuration register 0.

Data will continue to be transferred as long as the HyperBus master continues to transition the clock while CS# is Low. Legacy format wrapped bursts will continue to wrap within the burst length. Hybrid wrap will wrap once then switch to linear burst starting at the next wrap boundary. Linear burst accepts data in a sequential manner across page boundaries. Write transfers can be ended at any time by bringing CS# High when the clock is idle.

When a linear burst write reaches the last address in the memory array space, continuing the burst will write to the beginning of the address range.

The clock is not required to be free-running. The clock may remain idle while CS# is High.

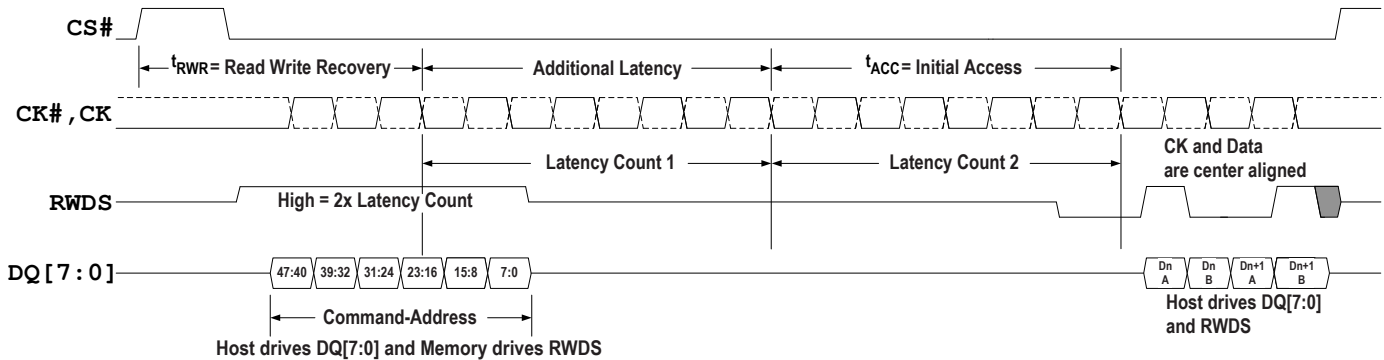

Figure 7 - Write Transaction with Additional Initial Latency

**Notes:**

1. Transactions must be initiated with CK=Low and CK#=High.
2. CS# must return High before a new transaction is initiated.
3. During CA, RWDS is driven by the memory and indicates whether additional latency cycles are required.
4. In this example, RWDS indicates that additional initial latency cycles are required.
5. At the end of CA cycles the memory stops driving RWDS to allow the host HyperBus master to begin driving RWDS. The master must drive RWDS to a valid Low before the end of the initial latency to provide a data mask preamble period to the slave.
6. During data transfer, RWDS is driven by the host to indicate which bytes of data should be either masked or loaded into the array.
7. The figure shows RWDS masking byte Dn A and byte Dn+1 B to perform an unaligned word write to bytes Dn B and Dn+1 A.

*The above information is the exclusive intellectual property of Winbond Electronics and shall not be disclosed, distributed or reproduced without permission from Winbond.*

Publication Release Date: Sep. 03, 2020  
Revision: A01-001



**7.4 Write Transactions without Initial Latency (Register Write)**

A Write transaction starts with the first three clock cycles providing the Command/Address information indicating the transaction characteristics. CA0 may indicate that a Write transaction is to be performed and also indicates the address space and burst type (wrapped or linear).

Writes without initial latency are used for register space writes. HyperRAM device write transactions with zero latency mean that the CA cycles are followed by write data transfers. Writes with zero initial latency, do not have a turnaround period for RWDS. The HyperRAM device will always drive RWDS during the CA period to indicate whether extended latency is required for a transaction that has initial latency. However, the RWDS is driven before the HyperRAM devices has received the first byte of CA i.e. before the HyperRAM device knows whether the transaction is a read or write to register space. In the case of a write with zero latency, the RWDS state during the CA period does not affect the initial latency of zero. Since master write data immediately follows the CA period in this case, the HyperRAM device may continue to drive RWDS Low or may take RWDS to High-Z during write data transfer. The master must not drive RWDS during Writes with zero latency. Writes with zero latency do not use RWDS as a data mask function. All bytes of write data are written (full word writes).

The first byte of data in each word is presented on the rising edge of CK and the second byte is presented on the falling edge of CK. Write data is center aligned with the clock inputs. Write transfers can be ended at any time by bringing CS# High when clock is idle. The clock is not required to be free-running.

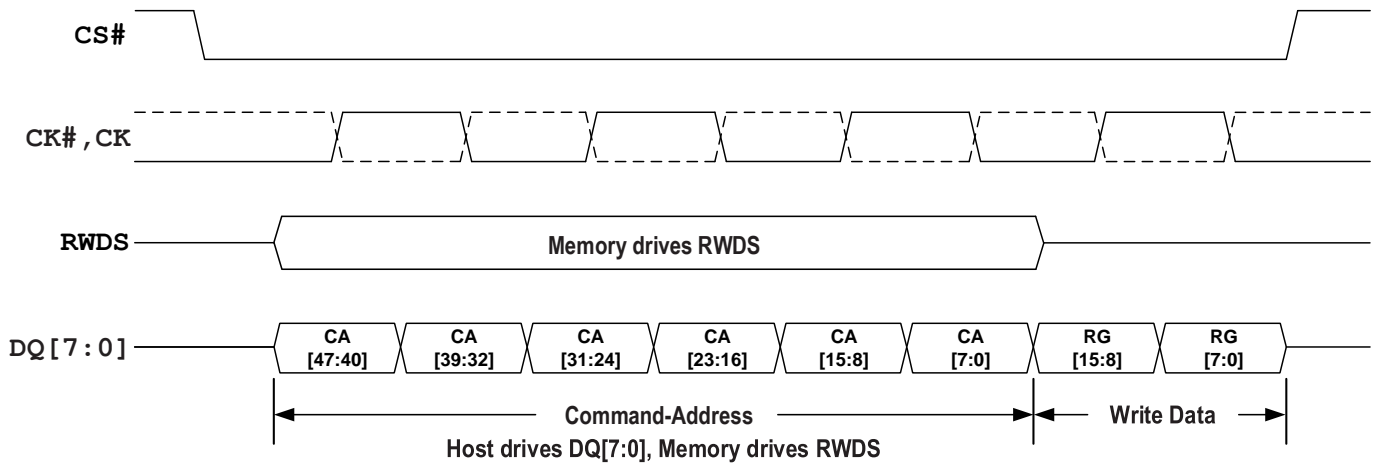

**Figure 8 - Write Operation without Initial Latency**

*The above information is the exclusive intellectual property of Winbond Electronics and shall not be disclosed, distributed or reproduced without permission from Winbond.*

*Publication Release Date: Sep. 03, 2020  
Revision: A01-001*



**8. MEMORY SPACE**

**8.1 HyperBus Interface Memory Space addressing**

**Table 3 - Memory Space Address Map (word based - 16 bits)**

Unit Type	Count	System Word Address Bits	CA Bits	Notes
Rows within 128 Mb device	16384 (Rows)	A22~A9	35~22	
Row	1 (row)	A8~A3	21~16	512 (word addresses) 1K bytes
Half-Page	8 (word addresses)	A2~A0	2~0	8 words (16 bytes)

**Table 4 - Memory Space Address Map (word based - 16 bits)**

		128Mb
Row Address	System Word Address Bits	A22~A9
	CA Bits	35~22
Column Address	System Word Address Bits	A8~A0
	CA Bits	21~16; 2~0
Half-Page (HP) Address	System Word Address Bits	A8~A3
	CA Bits	21~16
Word of HP Address	System Word Address Bits	A2~A0
	CA Bits	2~0

**Notes:**

1. Each row has 64 Half-pages. Each Half-page has 8 words. Each column has 512 words (1K bytes).
2. Half-Page address is also named as upper column address. Word of HP address is also named as lower column address.

**8.1.1 Density and Row Boundaries**

The DRAM array size (density) of the device can be determined from the total number of system address bits used for the row and column addresses as indicated by the Row Address Bit Count and Column Address Bit Count fields in the ID0 register. For example: a 64-Mbit HyperRAM device has 9 column address bits and 13 row address bits for a total of 22 word address bits =  $2^{22} = 4M$  words = 8M bytes. The 9 column address bits indicate that each row holds  $2^9 = 512$  words = 1K bytes. The row address bit count indicates there are 8192 rows to be refreshed within each array refresh interval. The row count is used in calculating the refresh interval.

*The above information is the exclusive intellectual property of Winbond Electronics and shall not be disclosed, distributed or reproduced without permission from Winbond.*

*Publication Release Date: Sep. 03, 2020  
Revision: A01-001*



**9. REGISTER SPACE**

**9.1 HyperBus Interface Register Addressing**

When CA[46] is 1 a read or write transaction accesses the Register Space.

**Table 5 - Register Space Address Map (for 2 Die DDP 128Mb)**

Register	System Address	—	—	—	31~27	26~24	23~22	21~19	18~11	10~3	—	2~0
	CA Bits	47	46	45	44~40	39~37	36~35	34~32	31~24	23~16	15~8	7~0
128 Mb Identification Register 0- Die 0	Read				000b	00b	000b	00h	00h	00h	00h	00h
128 Mb Identification Register 0- Die 1	Read				000b	01b	000b	00h	00h	00h	00h	00h
128 Mb Identification Register 1- Die 0	Read				000b	00b	000b	00h	00h	00h	00h	01h
128 Mb Identification Register 1- Die 1	Read				000b	01b	000b	00h	00h	00h	00h	01h
128 Mb Configuration Register 0- Die 0	Read/Write				000b	00b	000b	01h	00h	00h	00h	00h
128 Mb Configuration Register 0- Die 1	Read/Write				000b	01b	000b	01h	00h	00h	00h	00h
128 Mb Configuration Register 1- Die 0	Read/Write				000b	00b	000b	01h	00h	00h	00h	01h
128 Mb Configuration Register 1- Die 1	Read/Write				000b	01b	000b	01h	00h	00h	00h	01h

**Note:**

CA45 may be either 0 or 1 for either wrapped or linear read. CA45 must be 1 as only linear single word register writes are supported. The Burst type (wrapped/linear) definition is not supported in Register Reads. Hence C0h/E0h have the same effect.

*The above information is the exclusive intellectual property of Winbond Electronics and shall not be disclosed, distributed or reproduced without permission from Winbond.*

*Publication Release Date: Sep. 03, 2020  
Revision: A01-001*



## 9.2 Register Space Access

Register default values are loaded upon power-up or hardware reset. The registers can be altered at any time while the device is in the standby state.

Loading a register is accomplished with write transaction without initial latency using a single 16-bit word write transaction.

Each register is written with a separate single word write transaction. Register write transactions have zero latency, the single word of data immediately follows the CA. RWDS is not driven by the host during the write because RWDS is always driven by the memory during the CA cycles to indicate whether a memory array refresh is in progress. Because a register space write goes directly to a register, rather than the memory array, there is no initial write latency, related to an array refresh that may be in progress. In a register write, RWDS is also not used as a data mask because both bytes of a register are always written and never masked.

Reserved register fields must be written with their default value. Writing reserved fields with other than default values may produce undefined results.

**Note:** The host must not drive RWDS during a write to register space.

**Note:** The RWDS signal is driven by the memory during the CA period based on whether the memory array is being refreshed. This refresh indication does not affect the writing of register data.

**Note:** The RWDS signal returns to high impedance after the CA period. Register data is never masked. Both data bytes of the register data are loaded into the selected register.

Reading of a register is accomplished with read transaction with double initial latency using a single 16 bit read transaction. If more than one word is read, the same register value is repeated in each word read. The contents of the register is returned in the same manner as reading array data, with two latency counts, based on the state of RWDS during the CA period. The latency count is defined in the Configuration Register 0 Read Latency field (CR0[7:4]).

*The above information is the exclusive intellectual property of Winbond Electronics and shall not be disclosed, distributed or reproduced without permission from Winbond.*

*Publication Release Date: Sep. 03, 2020  
Revision: A01-001*



### 9.3 Device Identification Registers

There are two read only, non-volatile, word registers, that provide information on the device selected when CS# is low. The device information fields identify:

- Manufacture
- Type
- Density
  - Row address bit count
  - Column address bit count

**Table 6 - ID Register 0 Bit Assignments**

Bits	Function	Settings (Binary)
[15:14]	DDP Die Address	00b - Die 0 01b - Die 1 10b - Reserved 11b - Reserved
[13]	Reserved	0b - default
[12:8]	Row Address Bit Count	01100b - The 13th row address bits*
[7:4]	Column Address Bit Count	1000b - The 9th column address bits
[3:0]	Manufacturer	<b>0110b - Winbond</b>

**Note:** For each die.

**Table 7 - ID Register 1 Bit Assignments**

Bits	Function	Settings (Binary)
[15:4]	Reserved	0000_0000_0000b (default)
[3:0]	Device Type	0001b – HyperRAM 2.0 0000b, 0010b to 1111b - Reserved

### 9.4 Configuration Register 0

Configuration Register 0 (CR0) is used to define the power state and access protocol operating conditions for the HyperRAM device. Configurable characteristics include:

- Wrapped Burst Length (16, 32, 64, or 128 byte aligned and length data group)
- Wrapped Burst Type
  - Legacy wrapped burst (sequential access with wrap around within a selected length and aligned group)
  - Hybrid wrap (Legacy wrapped burst once then linear burst at start of the next sequential group)
- Initial Latency
- Fixed Latency
  - The memory array read or writes transaction use fixed latency will always indicate a refresh latency and delay the read data transfer accordingly.
- Output Drive Strength
- Deep Power Down Mode

*The above information is the exclusive intellectual property of Winbond Electronics and shall not be disclosed, distributed or reproduced without permission from Winbond.*

*Publication Release Date: Sep. 03, 2020  
Revision: A01-001*



Table 8 - Configuration Register 0 Bit Assignments

CR0 Bit	Function	Settings (Binary)
[15]	Deep Power Down Enable	1b - Normal operation (default) 0b - Deep Power Down mode <b>Note:</b> <b>Only the accessed die get into Deep Power Down (DPD) mode when write “0” to CR0[15], these stacked dual dies in DDP package are not able to stay at DPD mode simultaneously.</b>
[14:12]	Drive Strength	000b - 34 ohms (default) 001b - 115 ohms 010b - 67 ohms 011b - 46 ohms 100b - 34 ohms 101b - 27 ohms 110b - 22 ohms 111b - 19 ohms
[11:8]	Reserved	1b - Reserved (default) Reserved for Future Use. When writing this register, these bits should be set to 1 for future compatibility.
[7:4]	Initial Latency	0000b - 5 Clock Latency @ 133MHz Max Frequency 0001b - 6 Clock Latency @ 166MHz Max Frequency 0010b - 7 Clock Latency @ 200MHz Max Frequency (default) 0011b - Reserved 0100b - Reserved ... 1101b - Reserved 1110b - 3 Clock Latency @ 83MHz Max Frequency 1111b - 4 Clock Latency @ 100MHz Max Frequency
[3]	Fixed Latency	1b - Fixed 2 times Initial Latency (default) <b>Note:</b> <b>CR0[3] of each die of this DDP package must be programmed as “1” (Fixed Latency mode).</b>
[2]	Hybrid Burst Enable	0b: Wrapped burst sequences to follow hybrid burst sequencing 1b: Wrapped burst sequences in legacy wrapped burst manner (default)
[1:0]	Burst Length	00b - 128 bytes 01b - 64 bytes 10b - 16 bytes 11b - 32 bytes (default)

#### 9.4.1 Wrapped Burst

A wrapped burst transaction accesses memory within a group of words aligned on a word boundary matching the length of the configured group. Wrapped access groups can be configured as 16, 32, 64, or 128 bytes alignment and length. During wrapped transactions, access starts at the CA selected location within the group, continues to the end of the configured word group aligned boundary, then wraps around to the beginning location in the group, then continues back to the starting location. Wrapped bursts are generally used for critical word first instruction or data cache line fill read accesses.

*The above information is the exclusive intellectual property of Winbond Electronics and shall not be disclosed, distributed or reproduced without permission from Winbond.*

*Publication Release Date: Sep. 03, 2020  
Revision: A01-001*



## 9.4.2 Hybrid Burst

The beginning of a hybrid burst will wrap within the target address wrapped burst group length before continuing to the next half-page of data beyond the end of the wrap group. Continued access is in linear burst order until the transfer is ended by returning CS# High. This hybrid of a wrapped burst followed by a linear burst starting at the beginning of the next burst group, allows multiple sequential address cache lines to be filled in a single access. The first cache line is filled starting at the critical word. Then the next sequential line in memory can be read in to the cache while the first line is being processed.

**Table 9 - CR0[2] Control of Wrapped Burst Sequence**

Bit	Default Value	Name
2	1	Hybrid Burst Enable CR0[2]= 0b: Wrapped burst sequences to follow hybrid burst sequencing CR0[2]= 1b: Wrapped burst sequences in legacy wrapped burst manner

**Table 10 - Example Wrapped Burst Sequences (HyperBus Addressing)**

Burst Type	Wrap Boundary (Bytes)	Start Address (Hex)	Address Sequence (Hex) (Words)
Hybrid 128	128 Wrap once then Linear	XXXXXX03	03, 04, 05, 06, 07, 08, 09, 0A, 0B, 0C, 0D, 0E, 0F, 10, 11, 12, 13, 14, 15, 16, 17, 18, 19, 1A, 1B, 1C, 1D, 1E, 1F, 20, 21, 22, 23, 24, 25, 26, 27, 28, 29, 2A, 2B, 2C, 2D, 2E, 2F, 30, 31, 32, 33, 34, 35, 36, 37, 38, 39, 3A, 3B, 3C, 3D, 3E, 3F, 00, 01, 02 (Wrap complete, now linear beyond the end of the initial 128 byte wrap group) 40, 41, 42, 43, 44, 45, 46, 47, 48, 49, 4A, 4B, 4C, 4D, 4E, 4F, 50, 51, ...
Hybrid 64	64 Wrap once then Linear	XXXXXX03	03, 04, 05, 06, 07, 08, 09, 0A, 0B, 0C, 0D, 0E, 0F, 10, 11, 12, 13, 14, 15, 16, 17, 18, 19, 1A, 1B, 1C, 1D, 1E, 1F, 00, 01, 02, (Wrap complete, now linear beyond the end of the initial 64 byte wrap group) 20, 21, 22, 23, 24, 25, 26, 27, 28, 29, 2A, 2B, 2C, 2D, 2E, 2F, 30, 31, ...
Hybrid 64	64 Wrap once then Linear	XXXXXX2E	2E, 2F, 30, 31, 32, 33, 34, 35, 36, 37, 38, 39, 3A, 3B, 3C, 3D, 3E, 3F, 20, 21, 22, 23, 24, 25, 26, 27, 28, 29, 2A, 2B, 2C, 2D, (Wrap complete, now linear beyond the end of the initial 64 byte wrap group) 40, 41, 42, 43, 44, 45, 46, 47, 48, 49, 4A, 4B, 4C, 4D, 4E, 4F, 50, 51, ...
Hybrid 16	16 Wrap once then Linear	XXXXXX02	02, 03, 04, 05, 06, 07, 00, 01, (Wrap complete, now linear beyond the end of the initial 16 byte wrap group) 08, 09, 0A, 0B, 0C, 0D, 0E, 0F, 10, 11, 12, ...
Hybrid 16	16 Wrap once then Linear	XXXXXX0C	0C, 0D, 0E, 0F, 08, 09, 0A, 0B, (Wrap complete, now linear beyond the end of the initial 16 byte wrap group) 10, 11, 12, 13, 14, 15, 16, 17, 18, 19, 1A, ...
Hybrid 32	32 Wrap once then Linear	XXXXXX0A	0A, 0B, 0C, 0D, 0E, 0F, 00, 01, 02, 03, 04, 05, 06, 07, 08, 09 (Wrap complete, now linear beyond the end of the initial 32 byte wrap group) 10, 11, 12, 13, 14, 15, 16, 17, 18, 19, 1A, ...
Wrap 64	64	XXXXXX03	03, 04, 05, 06, 07, 08, 09, 0A, 0B, 0C, 0D, 0E, 0F, 10, 11, 12, 13, 14, 15, 16, 17, 18, 19, 1A, 1B, 1C, 1D, 1E, 1F, 00, 01, 02, ...
Wrap 64	64	XXXXXX2E	2E, 2F, 30, 31, 32, 33, 34, 35, 36, 37, 38, 39, 3A, 3B, 3C, 3D, 3E, 3F, 20, 21, 22, 23, 24, 25, 26, 27, 28, 29, 2A, 2B, 2C, 2D, ...
Wrap 16	16	XXXXXX02	02, 03, 04, 05, 06, 07, 00, 01, ...
Wrap 16	16	XXXXXX0C	0C, 0D, 0E, 0F, 08, 09, 0A, 0B, ...
Wrap 32	32	XXXXXX0A	0A, 0B, 0C, 0D, 0E, 0F, 00, 01, 02, 03, 04, 05, 06, 07, 08, 09, ...
Linear	Linear Burst	XXXXXX03	03, 04, 05, 06, 07, 08, 09, 0A, 0B, 0C, 0D, 0E, 0F, 10, 11, 12, 13, 14, 15, 16, 17, 18, ...

**Note:** Burst across die boundary is not supported in multi-die stack.

*The above information is the exclusive intellectual property of Winbond Electronics and shall not be disclosed, distributed or reproduced without permission from Winbond.*

Publication Release Date: Sep. 03, 2020  
Revision: A01-001



### 9.4.3 Initial Latency

Memory Space read and write transactions or Register Space read transactions require some initial latency to open the row selected by the CA. This initial latency is  $t_{ACC}$ . The number of latency clocks needed to satisfy  $t_{ACC}$  depends on the HyperBus frequency and can vary from 3 to 7 clocks. The value in CR0[7:4] selects the number of clocks for initial latency. The default value is 7 clocks, allowing for operation up to a maximum frequency of 200MHz prior to the host system setting a lower initial latency value that may be more optimal for the system.

In the event a distributed refresh is required at the time a Memory Space read or writes transaction or Register Space read transaction begins, the RWDS signal goes High during the CA to indicate that an additional initial latency is being inserted to allow a refresh operation to complete before opening the selected row.

Register Space write transactions always have zero initial latency. RWDS may be High or Low during the CA period. The level of RWDS during the CA period does not affect the placement of register data immediately after the CA, as there is no initial latency needed to capture the register data. A refresh operation may be performed in the memory array in parallel with the capture of register data.

### 9.4.4 Fixed Latency

A configuration register option bit CR0[3] is provided to make all Memory Space read and write transactions or Register Space read transactions require the same initial latency by always driving RWDS High during the CA to indicate that two initial latency periods are required. This fixed initial latency is independent of any need for a distributed refresh; it simply provides a fixed (deterministic) initial latency for all of these transaction types. The fixed latency option may simplify the design of some HyperBus memory controllers or ensure deterministic transaction performance. Fixed latency is the default POR or reset configuration. The system must not clear this configuration bit to "0b".

### 9.4.5 Drive Strength

DQ and RWDS signal line loading, length, and impedance vary depending on each system design. Configuration register bits CR0[14:12] provide a means to adjust the DQ[7:0] and RWDS signal output impedance to customize the DQ and RWDS signal impedance to the system conditions to minimize high speed signal behaviors such as overshoot, undershoot, and ringing. The default POR or reset configuration value is 000b to select the mid-point of the available output impedance options.

The impedance values shown are typical for both pull-up and pull-down drivers at typical silicon process conditions, nominal operating voltage (1.8V or 3.0V) and 50°C. The impedance values may vary from the typical values depending on the Process, Voltage, and Temperature (PVT) conditions. Impedance will increase with slower process, lower voltage, or higher temperature. Impedance will decrease with faster process, higher voltage, or lower temperature.

Each system design should evaluate the data signal integrity across the operating voltage and temperature ranges to select the best drive strength settings for the operating conditions.

### 9.4.6 Deep Power Down

When the HyperRAM device is not needed for system operation, it may be placed in a very low power consuming state called Deep Power Down (DPD), by writing 0 to CR0[15]. When CR0[15] is cleared to 0, the device enters the DPD state within  $t_{DPDIN}$  time and all refresh operations stop. The data in RAM is lost, (becomes invalid without refresh) during DPD state. Exiting DPD requires driving CS# Low then High, POR, or a reset. Only CS# and RESET# signals are monitored during DPD mode. All register contents are lost in Deep Power Down state and the device powers-up in its default state.

**Note: In this DDP package, only the current programmed die can stay in Deep Power Down (DPD) mode and the previous programmed die in DPD mode will exit DPD when write "0" to CR0[15] to the current programmed die.**

*The above information is the exclusive intellectual property of Winbond Electronics and shall not be disclosed, distributed or reproduced without permission from Winbond.*

*Publication Release Date: Sep. 03, 2020  
Revision: A01-001*



## 9.5 Configuration Register 1

Configuration Register 1 (CR1) is used to define the refresh array size, refresh rate and Hybrid Sleep for the HyperRAM device. Configurable characteristics include:

- Partial Array Refresh
- Hybrid Sleep State
- Refresh Rate

**Table 11 - Configuration Register 1 Bit Assignments**

CR1 Bit	Function	Settings (Binary)
[15-8]	Reserved	FFh - Reserved (default) Reserved for Future Use. When writing this register, these bits should keep FFh for future compatibility.
[7]	Reserved	1b - Reserved (default) When writing this register, this bit should keep 1b.
[6]	Master Clock Type	1b - Single Ended - CK (default) 0b - Differential - CK#, CK
[5]	Hybrid Sleep	1b - Hybrid Sleep 0b - Normal operation (default) <b>Note:</b> <b>Only the accessed die get into Hybrid Sleep mode when write “1” to CR1[5], these stacked dual dies in DDP package are not able to stay at Hybrid Sleep mode simultaneously.</b>
[4:2]	Partial Array Refresh	000b - Full Array (default) 001b - Bottom 1/2 Array 010b - Bottom 1/4 Array 011b - Bottom 1/8 Array 100b - None 101b - Top 1/2 Array 110b - Top 1/4 Array 111b - Top 1/8 Array <b>Note:</b> The array means default 64Mb density.
[1:0]	Distributed Refresh Interval	10b - Reserved 11b - Reserved 00b - Reserved 01b - 4 $\mu$ S tCSM <b>Note:</b> <b>CR1[1:0] is read only.</b>

### 9.5.1 Master Clock Type

Two clock types, namely single ended and differential, are supported by HyperRAM. CR1[6] selects which type to use.

### 9.5.2 Partial Array Refresh

The partial array refresh configuration restricts the refresh operation in HyperRAM to a portion of the memory array specified by CR1[4:2]. This reduces the standby current. The default configuration refreshes the whole array.

*The above information is the exclusive intellectual property of Winbond Electronics and shall not be disclosed, distributed or reproduced without permission from Winbond.*

*Publication Release Date: Sep. 03, 2020  
Revision: A01-001*



### 9.5.3 Hybrid Sleep

When the HyperRAM is not needed for system operation, it may be placed in Hybrid Sleep state if data in the device needs to be retained. Enter Hybrid Sleep state by writing 1 to CR1[5]. Bringing CS# Low will cause the device to exit HS state and set CR1[5] to 0. Also, POR, or a hardware reset will cause the device to exit Hybrid Sleep state. Note that a POR or a hardware reset disables refresh where the memory core data can potentially get lost.

**Note: In this DDP package, only the current programmed die can stay in Hybrid sleep (HS) mode and the previous programmed die in HS mode will exit HS when write “0” to CR1[5] to the current programmed die.**

### 9.5.4 Distributed Refresh Interval

The DRAM array requires periodic refresh of all bits in the array. This can be done by the host system by reading or writing a location in each row within a specified time limit. The read or write access copies a row of bits to an internal buffer. At the end of the access the bits in the buffer are written back to the row in memory, thereby recharging (refreshing) the bits in the row of DRAM memory cells.

HyperRAM devices include self-refresh logic that will refresh rows automatically. The automatic refresh of a row can only be done when the memory is not being actively read or written by the host system. The refresh logic waits for the end of any active read or write before doing a refresh, if a refresh is needed at that time. If a new read or write begins before the refresh is completed, the memory will drive RWDS high during the CA period to indicate that an additional initial latency time is required at the start of the new access in order to allow the refresh operation to complete before starting the new access.

The required refresh interval for the entire memory array varies with temperature as shown in Table 12 - Array Refresh Interval per Temperature. This is the time within which all rows must be refreshed. Refresh of all rows could be done as a single batch of accesses at the beginning of each interval, in groups (burst refresh) of several rows at a time, spread throughout each interval, or as single row refreshes evenly distributed throughout the interval. The self-refresh logic distributes single row refresh operations throughout the interval so that the memory is not busy doing a burst of refresh operations for a long period, such that the burst refresh would delay host access for a long period.

**Table 12 - Array Refresh Interval per Temperature**

Device Temperature (TCASE °C)	Array Refresh Interval (mS)	Array Rows	Recommended tCSM (µS)	CR1[1:0]
TCASE < 85	64	8192	4	01b

The distributed refresh method requires that the host does not do burst transactions that are so long as to prevent the memory from doing the distributed refreshes when they are needed. This sets an upper limit on the length of read and writes transactions so that the refresh logic can insert a refresh between transactions. This limit is called the CS# low maximum time (tCSM). The tCSM value is determined by the array refresh interval divided by the number of rows in the array, then reducing this calculation by half to ensure that a distributed refresh interval cannot be entirely missed by a maximum length host access starting immediately before a distributed refresh is needed. Because tCSM is set to half the required distributed refresh interval, any series of maximum length host accesses that delay refresh operations will catch up on refresh operations at twice the rate required by the refresh interval divided by the number of rows.

The host system is required to respect the tCSM value by ending each transaction before violating tCSM. This can be done by host memory controller logic splitting long transactions when reaching the tCSM limit, or by host system hardware or software not performing a single read or write transaction that would be longer than tCSM.

As noted in Table 12 - Array Refresh Interval per Temperature, the array refresh interval is longer at lower temperatures such that tCSM could be increased to allow longer transactions. The host system can either use the tCSM value from the table for the maximum operating temperature or, may determine the current operating temperature from a temperature sensor in the system in order to set a longer distributed refresh interval.

*The above information is the exclusive intellectual property of Winbond Electronics and shall not be disclosed, distributed or reproduced without permission from Winbond.*

*Publication Release Date: Sep. 03, 2020  
Revision: A01-001*



**9.6 Dual-Die-Package (DDP) Application**

**9.6.1 Die Stack Addressing**

**Table 13 - Die Stack Addressing**

HyperBus System Address	
Die 0	03FFFFFFh ~ 0000000h
Die 1	07FFFFFFh ~ 0400000h

**9.6.2 Burst Operations - Die Boundary Crossing**

Burst operation can be performed within one die. However, Burst reads and writes are not allowed crossing die boundaries.

**9.6.3 Die number assignment**

Each die in a DDP is allocated with different die number (Die 0 and Die 1).

**9.6.4 Latency mode**

For this DDP package Variable Latency mode is not allowed. Every operation must be under fixed latency mode and the CR0 [3] must be programmed as “1”. The CR0 [3] is defined as below.

CR0 Bit	Function	Settings (Binary)
[3]	Fixed Latency Enable	1b - Fixed 2 times Initial Latency (default) <b>Note:</b> <b>CR0[3] of each die of this DDP package must be programmed as “1” (Fixed Latency mode).</b>

In fixed latency mode, when CS# asserted LOW,

1. The RWDS signal of each die of DDP will always drive to HIGH during CA phase;
2. The RWDS signal of the non-selected die of DDP will always drive to Hi-Z after CA phase;
3. The RWDS signal of the selected die of DDP will drive to L after CA phase.

**9.6.5 IO pad capacitance**

For this DDP package all IO pad of each stacked die share same IO pin of package. It means that the IO capacitance of each IO pin of package will be 2 times than an IO pad of each stacked die.

*The above information is the exclusive intellectual property of Winbond Electronics and shall not be disclosed, distributed or reproduced without permission from Winbond.*

*Publication Release Date: Sep. 03, 2020  
Revision: A01-001*



**9.6.6 Current consumption**

For this DDP package the current consumption of standby will be 2 times than the consumption of each stacked die.

**9.6.7 Partial Refresh**

For this DDP package the area under partial refresh will be allocated into partial area of each stacked die. The CR1[4:2] must be programmed chip by chip.

CR1 Bit	Function	Settings (Binary)
[4:2]	Partial Array Refresh	000b - Full Array (default) 001b - Bottom 1/2 Array 010b - Bottom 1/4 Array 011b - Bottom 1/8 Array 100b - None 101b - Top 1/2 Array 110b - Top 1/4 Array 111b - Top 1/8 Array

**9.6.8 Hybrid Sleep Mode (HSM) and Deep Power Down (DPD) mode**

For this DDP package only one of stacked die can be either in HSM mode or DPD mode. It is not feasible to program all of stacked die in HSM or DPD mode.

CR0 Bit	Function	Settings (Binary)
[15]	Deep Power Down Enable	1b - Normal operation (default) 0b - Writing 0 to CR0[15] causes the device to enter Deep Power Down (DPD) <b>Notes:</b> <b>1. HyperRAM will automatically set the value of CR0[15] to “1” after exit DPD.</b> <b>2. Only the current programmed die can stay in Deep Power Down (DPD) mode and the previous programmed die in DPD mode will exit DPD when write “0” to CR0[15] to the current programmed die.</b>

CR1 Bit	Function	Settings (Binary)
[5]	Hybrid Sleep	1b - Writing 1 to CR1[5] causes the device to enter Hybrid Sleep (HS) State 0b - Normal operation (default) <b>Note:</b> <b>Only the current programmed die can stay in Hybrid sleep (HS) mode and the previous programmed die in HS mode will exit HS when write “0” to CR1[5] to the current programmed die.</b>

*The above information is the exclusive intellectual property of Winbond Electronics and shall not be disclosed, distributed or reproduced without permission from Winbond.*

*Publication Release Date: Sep. 03, 2020  
Revision: A01-001*



## 10. INTERFACE STATES

### 10.1 IO condition of interface states

Below Interface States table describes the required value of each signal for each interface state.

**Table 14 - Interface States**

Interface State	Vcc / Vccq	CS#	CK, CK#	DQ7-DQ0	RWDS	RESET#
Power-Off	$< V_{LKO}$	X	X	High-Z	High-Z	X
Power-On (Cold) Reset	Vcc / Vccq min	X	X	High-Z	High-Z	X
Hardware (Warm) Reset	Vcc / Vccq min	X	X	High-Z	High-Z	L
Interface Standby	Vcc / Vccq min	H	X	High-Z	High-Z	H
CA	Vcc / Vccq min	L	T	Master Output Valid	X	H
Read Initial Access Latency (data bus turn around period)	Vcc / Vccq min	L	T	High-Z	L	H
Write Initial Access Latency (RWDS turn around period)	Vcc / Vccq min	L	T	High-Z	High-Z	H
Read data transfer	Vcc / Vccq min	L	T	Slave Output Valid	Slave Output Valid X or T	H
Write data transfer with Initial Latency	Vcc / Vccq min	L	T	Master Output Valid	Master Output Valid X or T	H
Write data transfer without Initial Latency* <sup>1</sup>	Vcc / Vccq min	L	T	Master Output Valid	Slave Output L or High-Z	H
Active Clock Stop	Vcc / Vccq min	L	Idle	Master or Slave Output Valid or High-Z	X	H
Deep Power Down	Vcc / Vccq min	H	X or T	High-Z	High-Z	H
Hybrid Sleep	Vcc / Vccq min	H	X or T	High-Z	High-Z	H

#### Legend

L =  $V_{IL}$

H =  $V_{IH}$

X = either  $V_{IL}$ ,  $V_{IH}$ ,  $V_{OL}$  or  $V_{OH}$

L/H = rising edge

H/L = falling edge

T = Toggling during information transfer

Idle = CK is Low and CK# is High.

Valid = all bus signals have stable L or H level

#### Note:

- Writes without initial latency (with zero initial latency), do not have a turnaround period for RWDS. The HyperRAM device will always drive RWDS during the CA period to indicate whether extended latency is required. Since master write data immediately follows the CA period the HyperRAM device may continue to drive RWDS Low or may take RWDS to High-Z. The master must not drive RWDS during Writes with zero latency. Writes with zero latency do not use RWDS as a data mask function. All bytes of write data are written (full word writes).

*The above information is the exclusive intellectual property of Winbond Electronics and shall not be disclosed, distributed or reproduced without permission from Winbond.*

*Publication Release Date: Sep. 03, 2020  
Revision: A01-001*



## 10.2 Power Conservation Modes

### 10.2.1 Interface Standby

Standby is the default, low power, state for the interface while the device is not selected by the host for data transfer (CS# = High). All inputs and outputs other than CS# and RESET# are ignored in this state.

### 10.2.2 Active Clock Stop

The Active Clock Stop state reduces device interface energy consumption to the ICC6 level during the data transfer portion of a read or writes operation. The device automatically enables this state when clock remains stable for  $t_{ACC} + 30$  nS. While in Active Clock Stop state, read data is latched and always driven onto the data bus. Active Clock Stop state helps reduce current consumption when the host system clock has stopped to pause the data transfer. Even though CS# may be Low throughout these extended data transfer cycles, the memory device host interface will go into the Active Clock Stop current level at  $t_{ACC} + 30$  nS. This allows the device to transition into a lower current state if the data transfer is stalled. Active read or write current will resume once the data transfer is restarted with a toggling clock. The Active Clock Stop state must not be used in violation of the  $t_{CSM}$  limit. CS# must go High before  $t_{CSM}$  is violated. Note that it is recommended to stop the clock when it is in Low state.

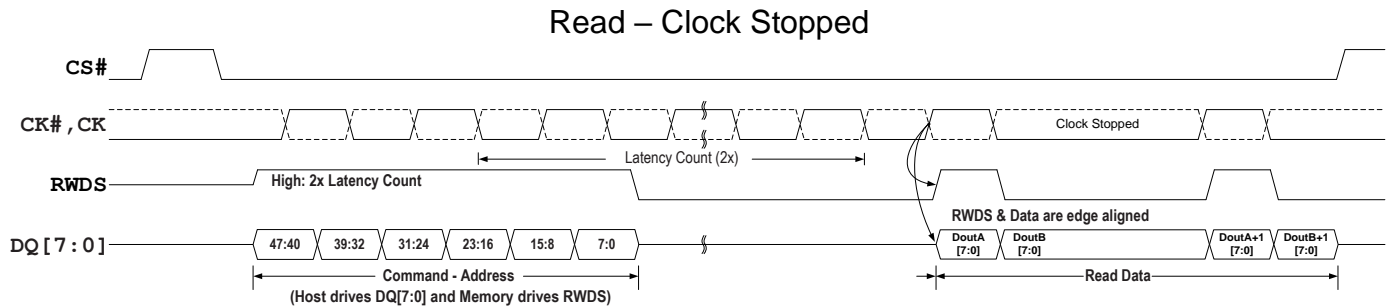

**Figure 9 - Active Clock Stop during Read Transaction (DDR)**

### 10.2.3 Hybrid Sleep

In the Hybrid Sleep (HS) state, the current consumption is reduced (I<sub>HS</sub>). HS state is entered by writing a 1 to CR1[5]. The device reduces power within  $t_{HSIN}$  time. The data in Memory Space and Register Space is retained during HS state. Bringing CS# Low will cause the device to exit HS state and set CR1[5] to 0. Also, POR, or a hardware reset will cause the device to exit HS state. Returning to Standby state requires  $t_{EXTHS}$  time. Following the exit from HS due to any of these events, the device is in the same state as entering HS.

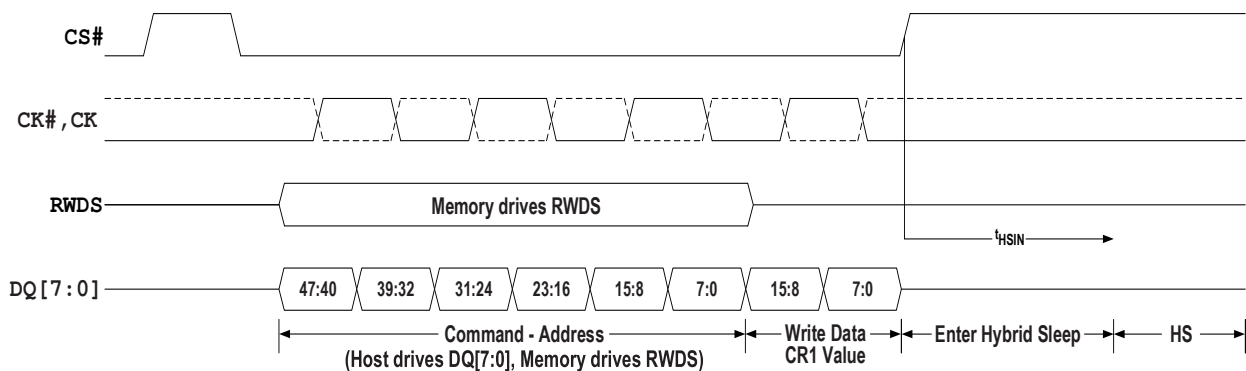

**Figure 10 - Enter Hybrid Sleep Transaction**

*The above information is the exclusive intellectual property of Winbond Electronics and shall not be disclosed, distributed or reproduced without permission from Winbond.*

Publication Release Date: Sep. 03, 2020  
Revision: A01-001

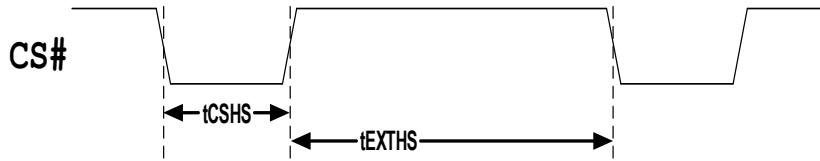

Figure 11 - Exit Hybrid Sleep Transaction

10.2.4 Deep Power Down

In the Deep Power down (DPD) state, current consumption is driven to the lowest possible level (iDPD). DPD state is entered by writing a 0 to CR0[15]. The device reduces power within tDPDIN time and all refresh operations stop. The data in Memory Space is lost, (becomes invalid without refresh) during DPD state. Driving CS# Low then High will cause the device to exit DPD state. Also, POR, or a hardware reset will cause the device to exit DPD state. Returning to Standby state requires tEXTDPD time. Returning to Standby state following a POR requires tvCS time, as with any other POR. Following the exit from DPD due to any of these events, the device is in the same state as following POR.

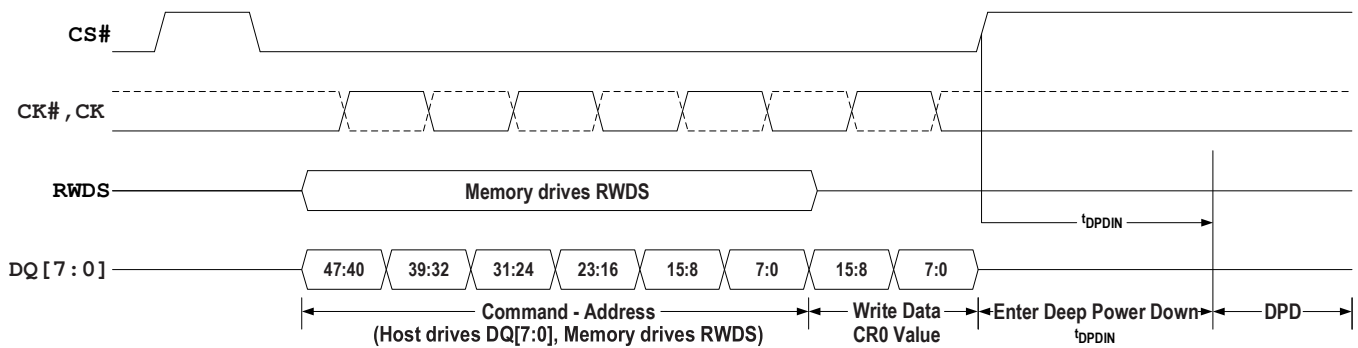

Figure 12 - Enter DPD Transaction



Figure 13 - Exit DPD Transaction

The above information is the exclusive intellectual property of Winbond Electronics and shall not be disclosed, distributed or reproduced without permission from Winbond.

Publication Release Date: Sep. 03, 2020  
Revision: A01-001



**11. ELECTRICAL SPECIFICATIONS**

**11.1 Absolute Maximum Ratings**

Parameter	Min	Max	Unit	Notes
Voltage on VCC,VCCQ supply relative to VSS	-0.5	VCC +0.5	V	1
Voltage to any ball except VCC relative to VSS	-0.5	VCC +0.5	V	1
Soldering temperature and time 10s (solder ball only)	+260		°C	1
Storage temperature (plastic)	-65	+150	°C	1
Output Short Circuit Current		100	mA	1, 2

**Notes:**

1. Stresses above those listed under Absolute Maximum Ratings may cause permanent damage to the device. This is a stress rating only; functional operation of the device at these or any other conditions above those indicated in the operational sections of this data sheet is not implied. Exposure of the device to absolute maximum rating conditions for extended periods may affect device reliability.
2. No more than one output may be shorted to ground at a time. Duration of the short circuit should not be greater than one second.

**11.2 Latch up Characteristics**

**Table 15 - Latch up Specification**

Description	Min	Max	Unit
Input voltage with respect to VSS on all input only connections	-1.0	VCC + 1.0	V
Input voltage with respect to VSSQ on all I/O connections	-1.0	VCCQ + 1.0	V
VCCQ Current	-100	+100	mA

**Note:**

1. Excludes power supplies Vcc/Vccq. Test conditions: Vcc = Vccq, one connection at a time tested, connections not being tested are at Vss.

**11.3 Operating Ranges**

**11.3.1 DC Characteristics**

Parameter	Description	Test Conditions	Min	Max	Unit
VCC,VCCQ	Power Supply 1.8V		1.7	2.0	V
VCC,VCCQ	Power Supply 3.0V		2.7	3.6	V
VIL	Input Low Voltage		-0.15 x VCC	0.3 x VCC	V
VIH	Input High Voltage		0.7 x VCC	1.15 x VCC	V
VOL	Output Low Voltage	IOL = 100µA for DQ[7:0]	–	0.2	V
VOH	Output High Voltage	IOH = 100µA for DQ[7:0]	VCCQ – 0.2	–	V

**Note:**

1. All parts list in order information table (section 2) will not guarantee to meet functional and AC specification if the Vcc, Vccq operation condition out of range mentioned in above table.

**11.3.2 Operating Temperature**

Parameter	Symbol	Range	Unit	Note
Operating Temperature	TCASE	-40~85	°C	1

**Note:**

1. All parts list in order information table (section 2) will not guarantee to meet functional and AC specification if the operation temperature range out of range mentioned in above table.

*The above information is the exclusive intellectual property of Winbond Electronics and shall not be disclosed, distributed or reproduced without permission from Winbond.*

*Publication Release Date: Sep. 03, 2020  
Revision: A01-001*



11.3.3 ICC Characteristics

Parameter	Description	Test Conditions	Min	Typ*1	Max	Unit
ILI1	Input Leakage Current 3.0V Device Reset Signal High Only	VIN = Vss to Vcc, Vcc = Vcc max	-	-	2	μA
ILI2	Input Leakage Current 1.8V Device Reset Signal High Only	VIN = Vss to Vcc, Vcc = Vcc max	-	-	2	μA
ILI3	Input Leakage Current 3.0V Device Reset Signal Low Only*2	VIN = Vss to Vcc, Vcc = Vcc max	-	-	15	μA
ILI4	Input Leakage Current 1.8V Device Reset Signal Low Only*2	VIN = Vss to Vcc, Vcc = Vcc max	-	-	15	μA
Icc1	Vcc Active Read Current	CS# = Vss, @200 MHz, Vcc = 2.0V	-	30	50	mA
		CS# = Vss, @200 MHz, Vcc = 3.6V	-	30	60	mA
		CS# = Vss, @166 MHz, Vcc = 3.6V	-	30	56	mA
Icc2	Vcc Active Write Current	CS# = Vss, @200 MHz, Vcc = 2.0V	-	30	50	mA
		CS# = Vss, @200 MHz, Vcc = 3.6V	-	30	60	mA
		CS# = Vss, @166 MHz, Vcc = 3.6V	-	30	56	mA
Icc5	Reset Current	CS# = Vcc, RESET# = Vss, Vcc = Vcc max	-	-	1.5	mA
Icc6	Active Clock Stop Current (-40°C to +85°C)	CS# = Vss, RESET# = Vcc, Vcc = Vcc max	-	10	13	mA
Icc7	Vcc Current during power up*1	CS# = Vcc, Vcc = Vcc max, Vcc = VccQ = 2.0V or 3.6V	-	-	70	mA

Parameter	Description	Test Conditions	Min	Typ*1	Max	Unit	
Icc4	VCC Standby Current (-40°C to +85°C)	CS# = Vcc, Vcc = 3.6V	Full Array	-	-	500	μA
			Bottom 1/2 Array	-	-	480	
			Bottom 1/4 Array	-	-	450	
			Bottom 1/8 Array	-	-	440	
			Top 1/2 Array	-	-	480	
			Top 1/4 Array	-	-	450	
			Top 1/8 Array	-	-	440	
Icc4	VCC Standby Current (-40°C to +85°C)	CS# = Vcc, Vcc = 2.0V	Full Array	-	-	440	μA
			Bottom 1/2 Array	-	-	420	
			Bottom 1/4 Array	-	-	410	
			Bottom 1/8 Array	-	-	400	
			Top 1/2 Array	-	-	420	
			Top 1/4 Array	-	-	410	
			Top 1/8 Array	-	-	400	

Notes:

1. Typical values are referring to the maximum root mean square value measured @ TCASE=25°C and for reference only, not tested in mass production process.
2. RESET# Low initiates exits from DPD state and initiates the draw of ICC5 reset current, making ILI during Reset# Low insignificant.

The above information is the exclusive intellectual property of Winbond Electronics and shall not be disclosed, distributed or reproduced without permission from Winbond.

Publication Release Date: Sep. 03, 2020  
Revision: A01-001



**11.3.4 Power-Up Initialization**

HyperRAM products include an on-chip voltage sensor used to launch the power-up initialization process. VCC and VCCQ must be applied simultaneously. When the power supply reaches a stable level at or above VCC (min), the device will require tvcs time to complete its self-initialization process.

The device must not be selected during power-up. CS# must follow the voltage applied on VCCQ until VCC (min) is reached during power-up, and then CS# must remain high for a further delay of tvcs. A simple pull-up resistor from VCCQ to Chip Select (CS#) can be used to insure safe and proper power-up.

If RESET# is Low during power up, the device delays start of the tvcs period until RESET# is High. The tvcs period is used primarily to perform refresh operations on the DRAM array to initialize it.

When initialization is complete, the device is ready for normal operation.

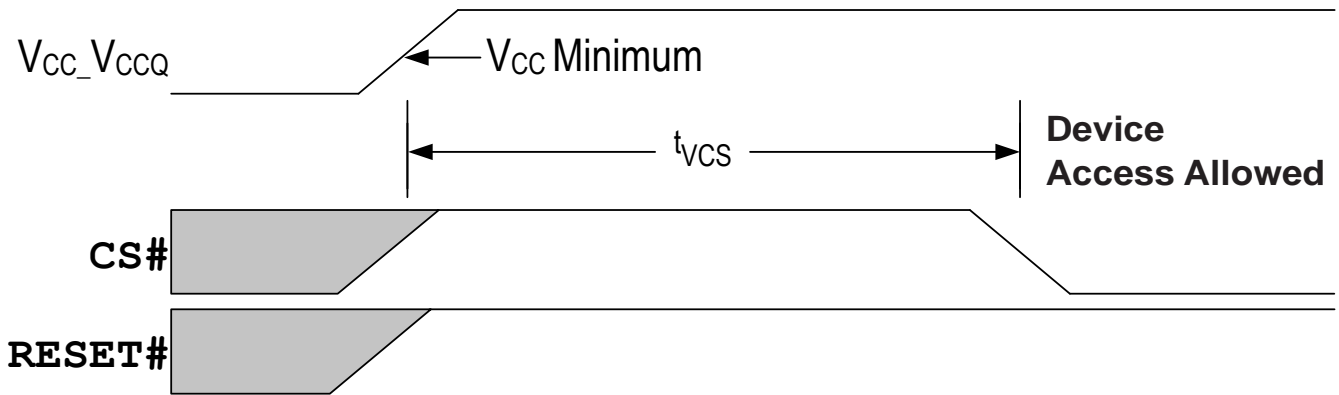

Figure 14 - Power-up with RESET# High

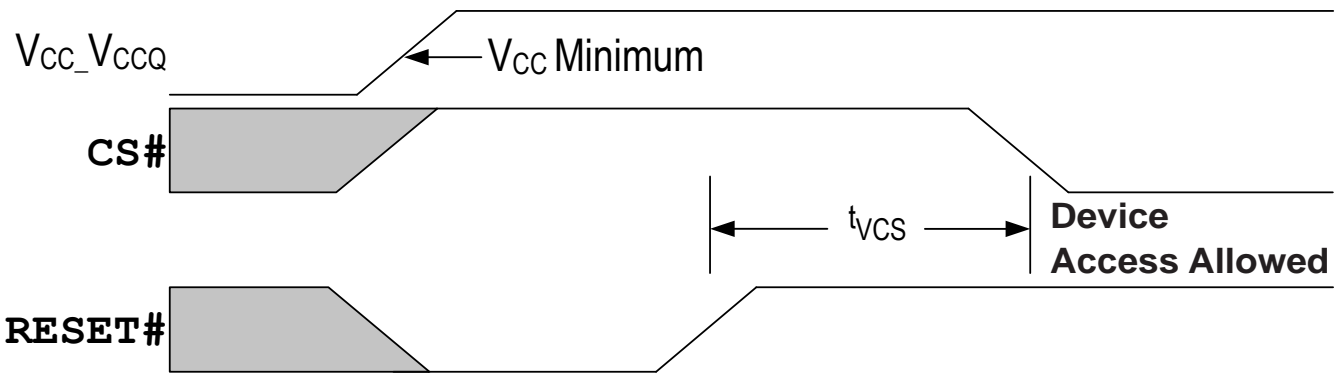

Figure 15 - Power-up with RESET# Low

Table 16 - Power Up and Reset Parameters

Parameter	Description	Min	Max	Unit
VCC	1.8V VCC Power Supply	1.7	2.0	V
VCC	3.0V VCC Power Supply	2.7	3.6	V
tvcs	VCC and VCCQ ≥ minimum and RESET# High to first access	-	150	μS

**Notes:**

1. Bus transactions (read and write) are not allowed during the power-up reset time (tvcs).
2. Vccq must be the same voltage as Vcc.
3. Vcc ramp rate may be non-linear.

*The above information is the exclusive intellectual property of Winbond Electronics and shall not be disclosed, distributed or reproduced without permission from Winbond.*

Publication Release Date: Sep. 03, 2020  
Revision: A01-001



**11.3.5 Power-Down**

HyperRAM devices are considered to be powered-off when the array power supplies (VCC) drops below the VCC Lock-Out voltage (VLKO). During a power supply transition down to the VSS level, VCCQ should remain less than or equal to VCC. At the VLKO level, the HyperRAM device will have lost configuration or array data.

VCC must always be greater than or equal to VCCQ ( $V_{CC} \geq V_{CCQ}$ ).

During Power-Down or voltage drops below VLKO, the array power supply voltages must also drop below VCC Reset (VRST) for a Power Down period (tPD) for the part to initialize correctly when the power supply again rises to VCC minimum. See Figure 16 - Power Down or Voltage Drop.

If during a voltage drop the VCC stays above VLKO the part will stay initialized and will work correctly when VCC is again above VCC minimum. If VCC does not go below and remain below VRST for greater than tPD, then there is no assurance that the POR process will be performed. In this case, a hardware reset will be required ensure the HyperBus device is properly initialized.

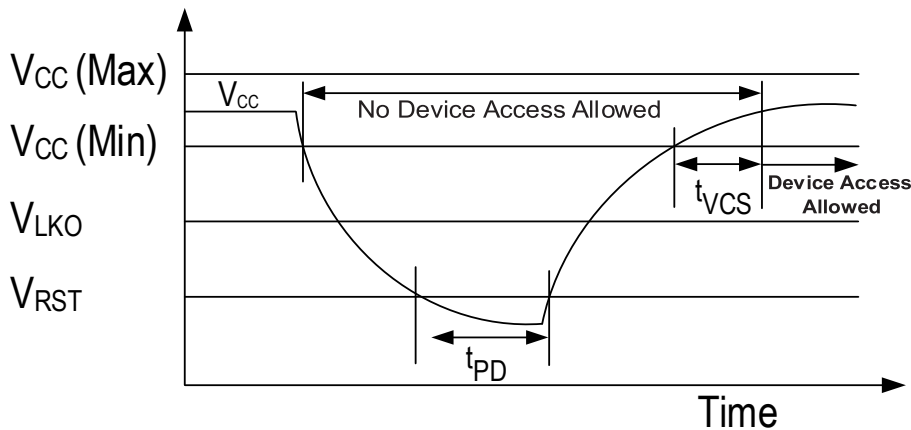

**Figure 16 - Power Down or Voltage Drop**

The following section describes HyperRAM device dependent aspects of power down specifications.

**Table 17 - Power-Down Voltage and Timing**

Parameter	Description	Min	Max	Unit
VCC	VCC Power Supply - 1.8V	1.7	2.0	V
VLKO	VCC Lock-out below which re-initialization is required - 1.8V	1.5	-	V
VCC	VCC Power Supply - 3.0V	2.7	3.6	V
VLKO	VCC Lock-out below which re-initialization is required - 3.0V	2.4	-	V
VRST	VCC Low Voltage needed to ensure initialization will occur	0.7	-	V
tPD	Duration of $V_{CC} \leq V_{RST}$	50	-	$\mu S$

**Note:** Vcc ramp rate can be non-linear.

*The above information is the exclusive intellectual property of Winbond Electronics and shall not be disclosed, distributed or reproduced without permission from Winbond.*

Publication Release Date: Sep. 03, 2020  
Revision: A01-001



**11.3.6 Hardware Reset**

The RESET# input provides a hardware method of returning the device to the standby state.

During t<sub>RP</sub> the device will draw ICC5 current. If RESET# continues to be held Low beyond t<sub>RP</sub>, the device draws CMOS standby current (ICC4). While RESET# is Low (during t<sub>RP</sub>), and during t<sub>RP</sub>, bus transactions are not allowed.

A hardware reset will:

- Cause the configuration registers to return to their default values
- Halt self-refresh operation while RESET# is low - memory array data is considered as invalid
- Force the device to exit the Hybrid Sleep state
- Force the device to exit the Deep Power Down state

After RESET# returns high, the self-refresh operation will resume. Because self-refresh operation is stopped during RESET# Low, and the self-refresh row counter is reset to its default value, some rows may not be refreshed within the required array refresh interval per Table 12 - Array Refresh Interval per Temperature on page 25. This may result in the loss of DRAM array data during or immediately following a hardware reset. The host system should assume DRAM array data is lost after hardware reset and reload any required data.

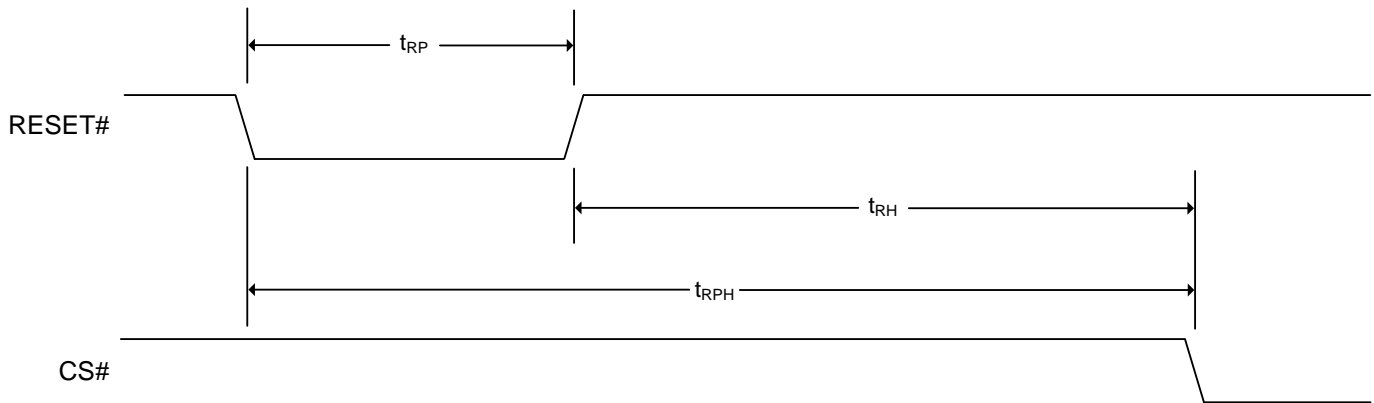

**Figure 17 - Hardware Reset Timing Diagram**

**Table 18 - Power Up and Reset Parameters**

Parameter	Description	Min	Max	Unit
t <sub>RP</sub>	RESET# Pulse Width	200	–	nS
t <sub>RH</sub>	Time between RESET# (High) and CS# (Low)	200	–	nS
t <sub>RPH</sub>	RESET# Low to CS# Low	400	–	nS

**Note:** The RESET# pin is 4V tolerant.

*The above information is the exclusive intellectual property of Winbond Electronics and shall not be disclosed, distributed or reproduced without permission from Winbond.*

*Publication Release Date: Sep. 03, 2020  
Revision: A01-001*



11.3.7 Capacitance Characteristics

Table 19 - 1.8V Capacitive Characteristics

Parameter	Description	Min	Max	Unit
CI	Input Capacitance (CK, CK#, CS#)		6.0	pF
CID	Delta Input Capacitance (CK, CK#)		0.25	pF
CO	Output Capacitance (RWDS)		6.0	pF
CIO	IO Capacitance (DQx)		6.0	pF
CIOD	IO Capacitance Delta (DQx)		0.25	pF

Table 20 - 3.0V Capacitive Characteristics

Parameter	Description	Min	Max	Unit
CI	Input Capacitance (CK, CK#, CS#)		6.0	pF
CID	Delta Input Capacitance (CK, CK#)		0.25	pF
CO	Output Capacitance (RWDS)		6.0	pF
CIO	IO Capacitance (DQx)		6.0	pF
CIOD	IO Capacitance Delta (DQx)		0.25	pF

Notes:

1. These values are guaranteed by design and are tested on a sample basis only.
2. These values are applies to die device only (does not include package capacitance).
3. Contact capacitance is measured according to JEP147 procedure for measuring capacitance using a vector network analyzer. VCC, VCCQ are applied and all other signals (except the signal under test) floating. DQ's should be in the high impedance state.
4. The capacitance values for the CK, CK#, RWDS and DQx signals must have similar capacitance values to allow for signal propagation time matching in the system. The capacitance value for CS# is not as critical because there are no critical timings between CS# going active (Low) and data being presented on the DQs bus.

11.4 Input Signal Overshoot

During DC conditions, input or I/O signals should remain equal to or between VSS and VCC. During voltage transitions, inputs or I/Os may negative overshoot VSS to -1.0V or positive overshoot to VCC +1.0V, for periods up to 20 nS.

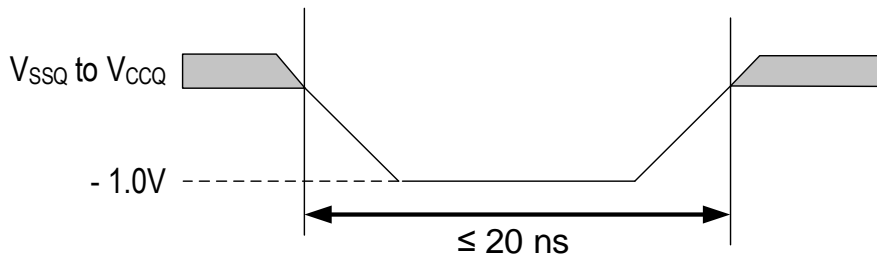

Figure 18 - Maximum Negative Overshoot Waveform

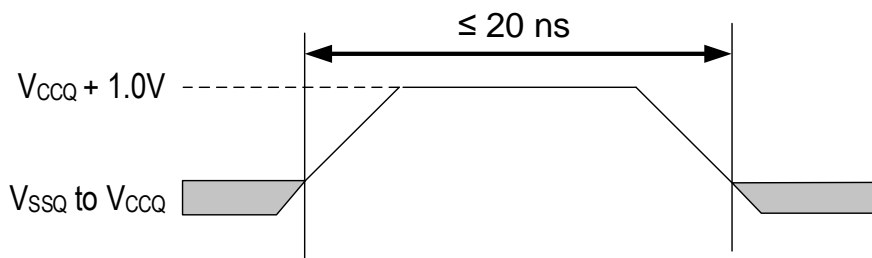

Figure 19 - Maximum Positive Overshoot Waveform

The above information is the exclusive intellectual property of Winbond Electronics and shall not be disclosed, distributed or reproduced without permission from Winbond.



**12. TIMING SPECIFICATIONS**

The following section describes HyperRAM device dependent aspects of timing specifications.

**12.1 Key to Switching Waveforms**

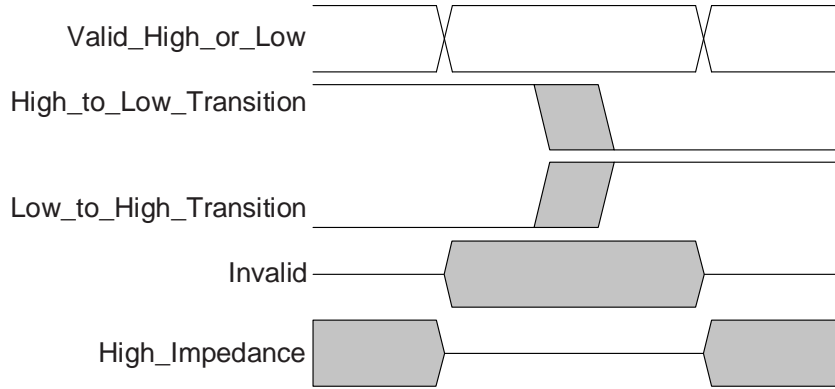

**12.2 AC Test Conditions**

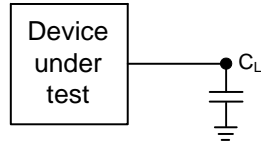

Figure 20 - Test load reference

Table 21 - Test Specification

Description	All	Unit	Notes
Output Load Capacitance, $C_L$	15	pF	
Minimum Input Rise and Fall Slew Rates (1.8V)	1.13	V/nS	1
Minimum Input Rise and Fall Slew Rates (3.0V)	2.06	V/nS	1
Input Pulse Levels	0-V <sub>CCQ</sub>	V	
Input timing measurement reference levels	V <sub>CCQ</sub> /2	V	2
Output timing measurement reference levels	V <sub>CCQ</sub> /2	V	2

**Notes:**

1. All AC timings assume this input slew rate.
2. Input and output timing is referenced to V<sub>CCQ</sub>/2 for single ended clock or RWDS or referenced to the crossing of CK/CK# for the differential clock pair.

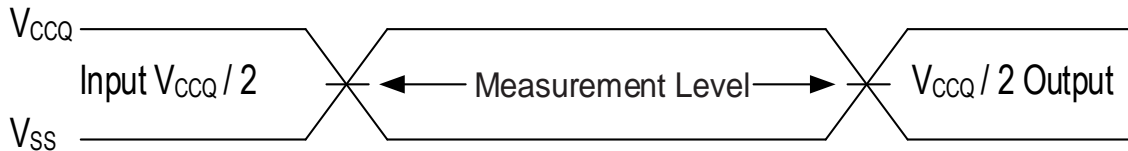

Figure 21 - Input Waveforms and Measurement Levels

*The above information is the exclusive intellectual property of Winbond Electronics and shall not be disclosed, distributed or reproduced without permission from Winbond.*

Publication Release Date: Sep. 03, 2020  
Revision: A01-001



12.3 Timing Reference Levels for  $t_{IS}$  and  $t_{IH}$

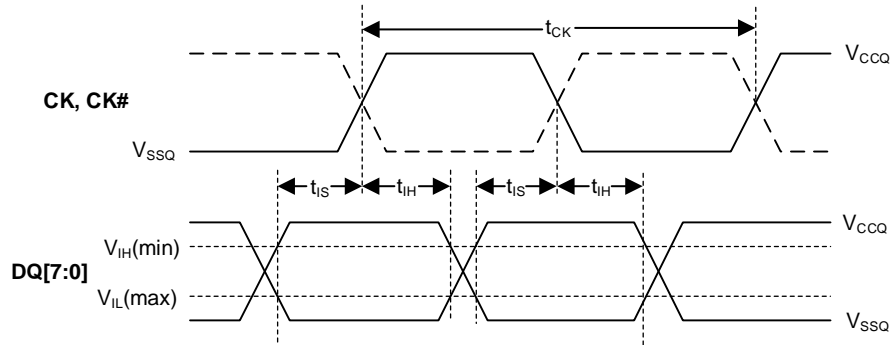

Figure 22 – DDR Input Timing Reference Levels

*The above information is the exclusive intellectual property of Winbond Electronics and shall not be disclosed, distributed or reproduced without permission from Winbond.*

*Publication Release Date: Sep. 03, 2020  
Revision: A01-001*



12.4 AC Characteristics

12.4.1 Read Transactions

Table 22 - HyperRAM Specific Read Timing Parameters

Parameter	Symbol	200 MHz		166 MHz		Unit
		Min	Max	Min	Max	
Chip Select High Between Transactions - 1.8 V	tCSHI	6	–	6	–	nS
Chip Select High Between Transactions - 3.0 V		6	–	6	–	
HyperRAM Read-Write Recovery Time - 1.8 V	tRWR	35	–	36	–	nS
HyperRAM Read-Write Recovery Time - 3.0 V		35	–	36	–	
Chip Select Setup to next CK Rising Edge	tCSS	4	–	3	–	nS
Data Strobe Valid - 1.8 V	tDSV	–	5	–	12	nS
Data Strobe Valid - 3.0 V		–	6.5	–	12	
Input Setup - 1.8 V	tIS	0.5	–	0.6	–	nS
Input Setup - 3.0 V		0.5	–	0.6	–	
Input Hold - 1.8 V	tIH	0.5	–	0.6	–	nS
Input Hold - 3.0 V		0.5	–	0.6	–	
HyperRAM Read Initial Access Time - 1.8 V	tACC	35	–	36	–	nS
HyperRAM Read Initial Access Time- 3.0 V		35	–	36	–	
Clock to DQs Low Z	tDQLZ	0	–	0	–	nS
CK transition to DQ Valid - 1.8 V	tCKD	1	5	1	5.5	nS
CK transition to DQ Valid - 3.0 V		1	6.5	1	7	
CK transition to DQ Invalid - 1.8 V	tCKDI	0	4.2	0	4.6	nS
CK transition to DQ Invalid - 3.0 V		0.5	5.7	0.5	5.6	
Data Valid - 1.8V	tDV	1.45	–	1.8	–	nS
Data Valid - 3.0V		1.45	–	1.3	–	
CK transition to RWDS Valid - 1.8 V	tCKDS	–	5	1	5.5	nS
CK transition to RWDS Valid - 3.0 V		–	6.5	1	7	
RWDS transition to DQ Valid - 1.8 V	tDSS	-0.4	+0.4	-0.45	+0.45	nS
RWDS transition to DQ Valid - 3.0 V		-0.4	+0.4	-0.8	+0.8	
RWDS transition to DQ Invalid - 1.8 V	tDSH	-0.4	+0.4	-0.45	+0.45	nS
RWDS transition to DQ Invalid - 3.0 V		-0.4	+0.4	-0.8	+0.8	
Chip Select Hold After CK Falling Edge	tCSH	0	–	0	–	nS
Chip Select Inactive to RWDS High-Z - 1.8 V	tDSZ	–	5	–	6	nS
Chip Select Inactive to RWDS High-Z - 3.0 V		–	6.5	–	7	
Chip Select Inactive to DQ High-Z - 1.8 V	toZ	–	5	–	6	nS
Chip Select Inactive to DQ High-Z - 3.0 V		–	6.5	–	7	
Refresh Time - 1.8 V	tRFH	35	–	36	–	nS
Refresh Time - 3.0 V		35	–	36	–	
CK transition to RWDS Low @CA phase @Read - 1.8 V	tCKDSR	1	5.5	1	5.5	nS
CK transition to RWDS Low @CA phase @Read - 3.0 V		1	7	1	7	

The above information is the exclusive intellectual property of Winbond Electronics and shall not be disclosed, distributed or reproduced without permission from Winbond.

Publication Release Date: Sep. 03, 2020  
Revision: A01-001

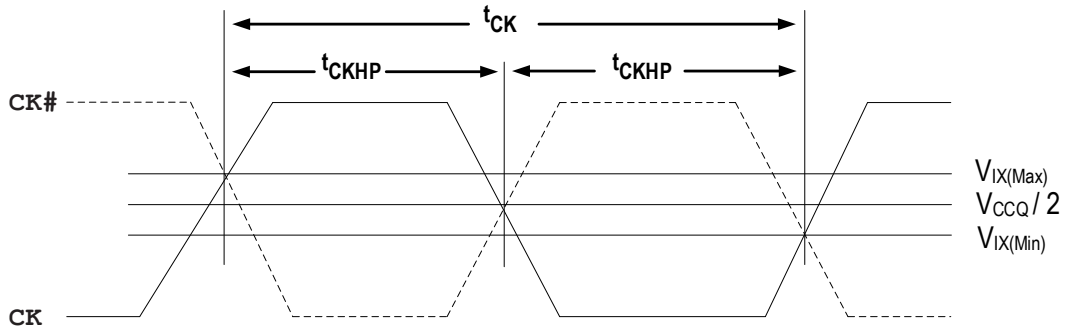

Figure 23 - Clock Characteristics

Table 23 - Clock Timings

Description	Parameter	166 MHz		200 MHz		Unit
		Min	Max	Min	Max	
CK Period	$t_{CK}$	6	–	5	–	nS
CK Half Period - Duty Cycle	$t_{CKHP}$	0.45	0.55	0.45	0.55	tCK
CK Half Period at Frequency Min = 0.45 tCK Min Max = 0.55 tCK Min	$t_{CKHP}$	2.7	3.3	2.25	2.75	nS

**Note:**

1. Clock jitter of  $\pm 5\%$  is permitted.
2. Minimum Frequency (Maximum  $t_{CK}$ ) is dependent upon maximum CS# Low time ( $t_{CSM}$ ), Initial Latency and Burst Length.
3. All parts list in order information table (section 2) will not guarantee to meet functional and AC specification if the  $t_{CK}$  and  $t_{CKHP}$  out of range mentioned in above table.

*The above information is the exclusive intellectual property of Winbond Electronics and shall not be disclosed, distributed or reproduced without permission from Winbond.*

Publication Release Date: Sep. 03, 2020  
Revision: A01-001



Table 24 - Clock AC/DC Electrical Characteristics

Description	Parameter	Min	Max	Unit
DC Input Voltage	$V_{IN}$	-0.3	$V_{CCQ} + 0.3$	V
DC Input Differential Voltage	$V_{ID(DC)}$	$V_{CCQ} \times 0.4$	$V_{CCQ} + 0.6$	V
AC Input Differential Voltage	$V_{ID(AC)}$	$V_{CCQ} \times 0.6$	$V_{CCQ} + 0.6$	V
AC Differential Crossing Voltage	$V_{IX}$	$V_{CCQ} \times 0.4$	$V_{CCQ} \times 0.6$	V

Differential Clock Input Levels

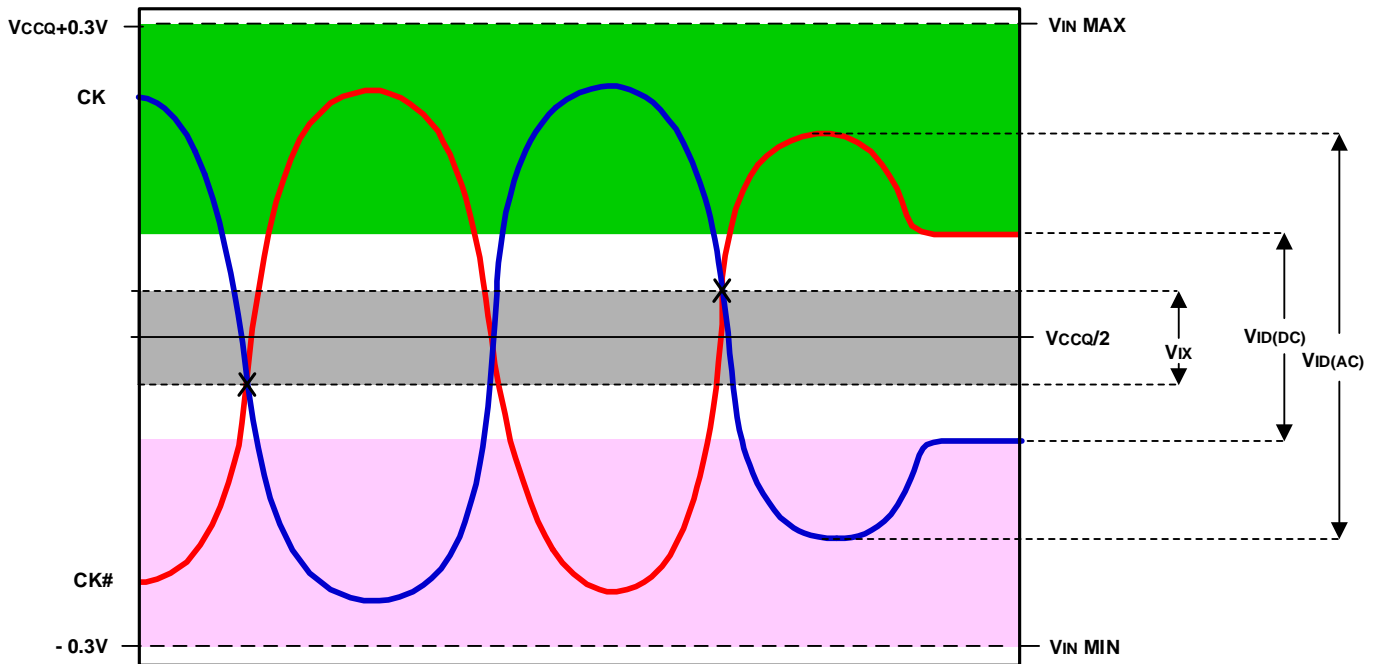

Notes:

1. CK and CK# input slew rate must be  $\geq 1V/nS$  ( $2V/nS$  if measured differentially).
2.  $V_{ID(DC)}$  is the magnitude of the difference between the input level on CK and the input level on CK# when the CK and CK# is stable at a certain voltage level.
3.  $V_{ID(AC)}$  is the magnitude of the difference between the input level on CK and the input level on CK# when the CK and CK# is transient within a range defined for  $V_{IN}$ .
4. The value of  $V_{IX}$  is expected to equal  $V_{CCQ}/2$  of the transmitting device and must track variations in the DC level of  $V_{CCQ}$ .

The above information is the exclusive intellectual property of Winbond Electronics and shall not be disclosed, distributed or reproduced without permission from Winbond.

Publication Release Date: Sep. 03, 2020  
Revision: A01-001

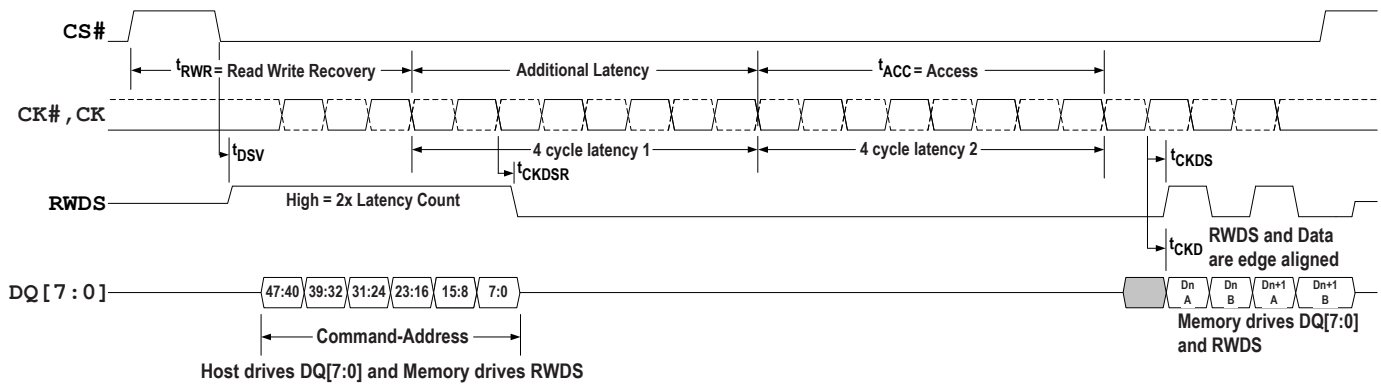

Figure 24 - Read Timing Diagram - With Additional Latency

**Notes:**

1. Timing parameters applicable to HyperBus interfaces.
2. Transactions must be initiated with CK = Low and CK# = High.
3. CS# must return High before a new transaction is initiated.
4. The memory drives RWDS during the entire Read transaction.
5. Transactions without additional latency count have RWDS Low during CA cycles. Transactions with additional latency count have RWDS High during CA cycles and RWDS returns low at  $t_{CKDSR}$ . All other timing relationships are the same for both figures although they are not shown in the second figure. A four cycle latency is used for illustration purposes only. The required latency count is device and clock frequency dependent.
6. These parameters are required by HyperRAM.

*The above information is the exclusive intellectual property of Winbond Electronics and shall not be disclosed, distributed or reproduced without permission from Winbond.*

*Publication Release Date: Sep. 03, 2020  
Revision: A01-001*

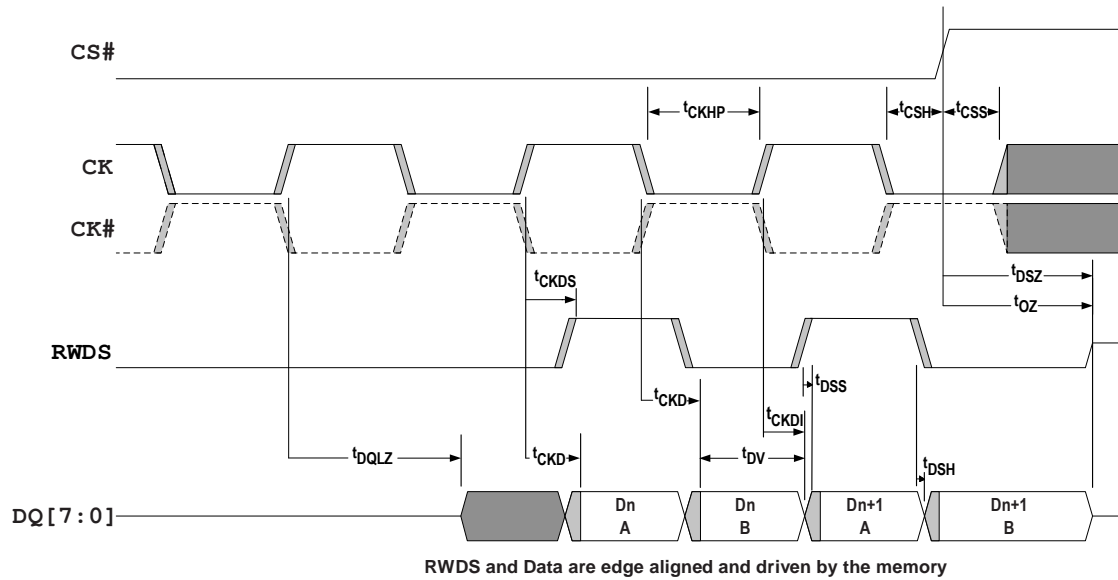

**Figure 25 - Data Valid Timing**

**Notes:**

1. This figure shows a closer view of the data transfer portion of read transaction diagrams to more clearly show the Data Valid period as affected by clock jitter and clock to output delay uncertainty.
2. The tCKD and tCKDI timing parameters define the beginning and end position of the data valid period.
3. The tDSS and tDSH timing parameters define how early or late RWDS may transition relative to the transition of data. This is the potential skew between the clock to data delay tCKD, and clock to data strobe delay tCKDS. Aside from this skew, the tCKD, tCKDI, and tCKDS values track together (vary by the same ratio) because RWDS and Data are outputs from the same device under the same voltage and temperature conditions.

**12.4.2 Write Transactions**

**Table 25 - Write Timing Parameters**

Parameter	Symbol	200 MHz		166 MHz		Unit
		Min	Max	Min	Max	
Read-Write Recovery Time - 1.8 V	t <sub>RWR</sub>	35	–	36	–	nS
Read-Write Recovery Time - 3.0 V		35	–	36	–	
Access Time - 1.8 V	t <sub>ACC</sub>	35	–	36	–	nS
Access Time - 3.0 V		35	–	36	–	
Refresh Time - 1.8 V	t <sub>RFH</sub>	35	–	36	–	nS
Refresh Time - 3.0 V		35	–	36	–	
Chip Select Maximum Low Time (TCASE < 85°C)	t <sub>CSM</sub>	–	4	–	4	µS
RWDS Data Mask Valid	t <sub>DMV</sub>	0	–	0	–	µS

*The above information is the exclusive intellectual property of Winbond Electronics and shall not be disclosed, distributed or reproduced without permission from Winbond.*

*Publication Release Date: Sep. 03, 2020  
Revision: A01-001*

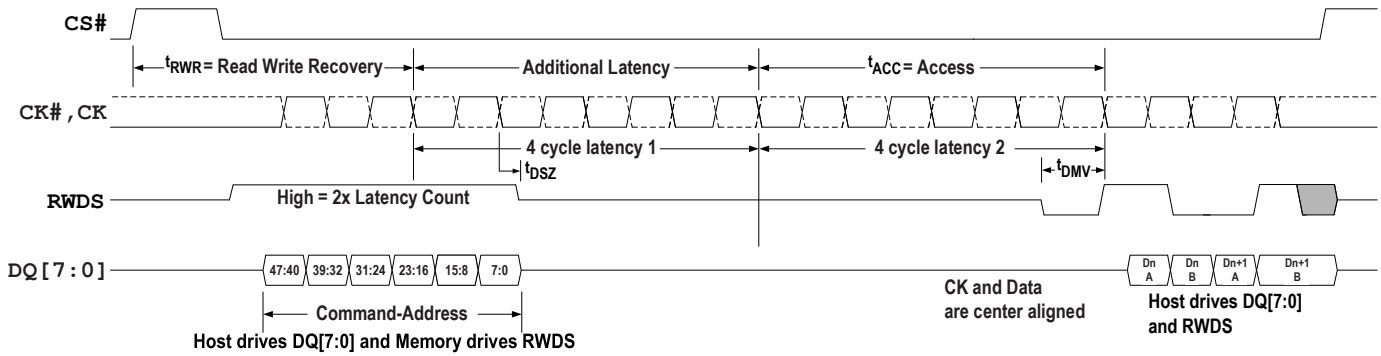

Figure 26 - Write Timing Diagram - With Additional Latency

**Notes:**

1. Timing parameters applicable to HyperBus interfaces.
2. Transactions must be initiated with CK=Low and CK#=High. CS# must return High before a new transaction is initiated.
3. During write transactions with latency, RWDS is used as an additional latency indicator initially and is then used as a data mask during data transfer.
4. Transactions without additional latency count have RWDS Low during CA cycles and RWDS returns Hi-Z at  $t_{DSZ}$ . Transactions with additional latency count have RWDS High during CA cycles and RWDS returns Hi-Z at  $t_{DSZ}$ . All other timing relationships are the same for both figures although they are not shown in the second figure. A four cycle latency is used for illustration purposes only. The required latency count is device and clock frequency dependent.
5. At the end of Command-Address cycles the memory stops driving RWDS to allow the host HyperBus master to begin driving RWDS. The master must drive RWDS to a valid Low before the end of the initial latency to provide a data mask preamble period to the slave. This can be done during the last cycle of the initial latency.
6. The write transaction shown demonstrates the Dn A byte and the Dn+1 B byte being masked. Only Dn B byte and Dn+1 A byte are modified in the array. Dn A byte and Dn+1 B byte remain unchanged.

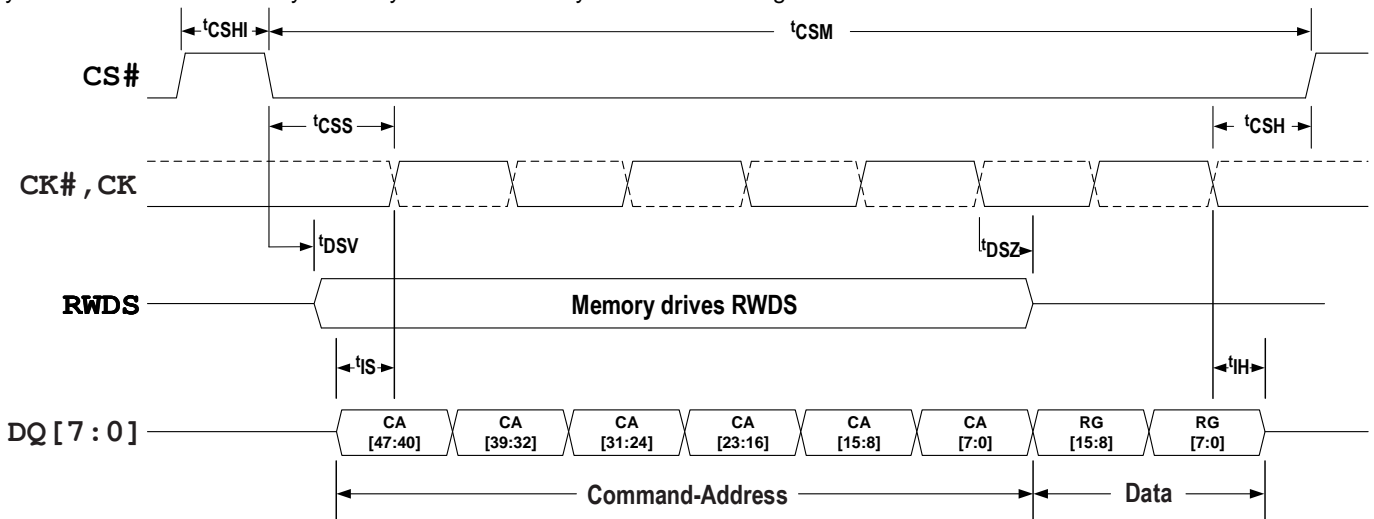

Figure 27 - Write Operation without Initial Latency (Register Write)

**Notes:**

1. Transactions must be initiated with CK=Low and CK#=High. CS# must return High before a new transaction is initiated.
2. Writes without Initial Latency, do not have a turnaround period for RWDS. The slave device will always drive RWDS during the Command-Address period to indicate whether extended latency is required for a transaction that has initial latency. However, the RWDS is driven before the slave device has received the first byte of CA, that is, before the slave knows whether the transaction is a read or write, to memory space or register space. In the case of a write without Initial Latency, the RWDS state during the CA period does not affect the Latency of Register Write. Since master write data immediately follows the Command-Address period in this case, the slave may continue to drive RWDS Low or may take RWDS to High-Z during write data transfer. The master must not drive RWDS during Register Write. Register Write do not use RWDS as a data mask function. All bytes of write data are written (full word writes).

*The above information is the exclusive intellectual property of Winbond Electronics and shall not be disclosed, distributed or reproduced without permission from Winbond.*



### 12.4.3 Hybrid Sleep Timings

Table 26 - Hybrid Sleep Timing Parameters

Description	Parameter	Min	Max	Unit
Hybrid Sleep CR1[5]=1 register write to Hybrid Sleep power level	tHSIN	–	3	μS
CS# Pulse Width to Exit Hybrid Sleep	tCSHS	60	3000	nS
CS# Exit Hybrid Sleep to Standby wakeup time	tEXTHS	–	100	μS

### 12.4.4 Deep Power down Timings

Table 27 - Deep Power down Timing Parameters

Description	Parameter	Min	Max	Unit
Deep Power Down CR0[15]=0 register write to DPD power level	tDPDIN	–	3	μS
CS# Pulse Width to Exit DPD	tCSDPD	200	3000	nS
CS# Exit Deep Power Down to Standby wakeup time	tEXTDPD	–	150	μS

*The above information is the exclusive intellectual property of Winbond Electronics and shall not be disclosed, distributed or reproduced without permission from Winbond.*

*Publication Release Date: Sep. 03, 2020  
Revision: A01-001*



13. PACKAGE SPECIFICATION

Package Outline TFBGA24 Ball (6x8 mm<sup>2</sup> (5x5-1 ball arrays), Ball pitch: 1.00mm, Ø=0.40mm)

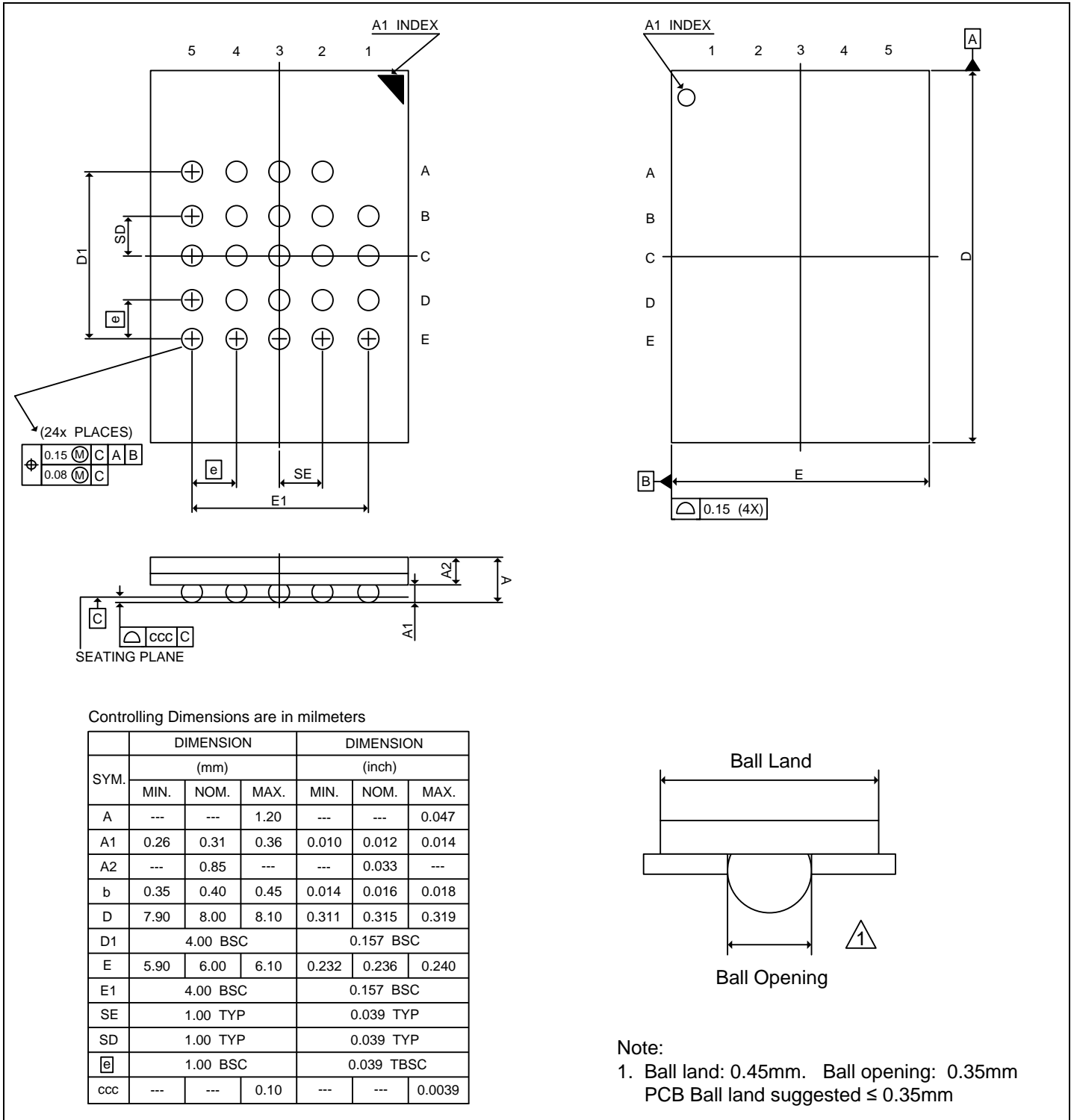

The above information is the exclusive intellectual property of Winbond Electronics and shall not be disclosed, distributed or reproduced without permission from Winbond.

Publication Release Date: Sep. 03, 2020  
 Revision: A01-001



**14. REVISION HISTORY**

VERSION	DATE	PAGE	DESCRIPTION
A01-001	Sep. 03, 2020	All	Initial formal datasheet

**Note: The content of this document is subject to change without notice.**

---

*Please note that all data and specifications are subject to change without notice.  
All the trademarks of products and companies mentioned in this datasheet belong to their respective owners.*

*The above information is the exclusive intellectual property of Winbond Electronics and shall not be disclosed, distributed or reproduced without permission from Winbond.*

*Publication Release Date: Sep. 03, 2020  
Revision: A01-001*