

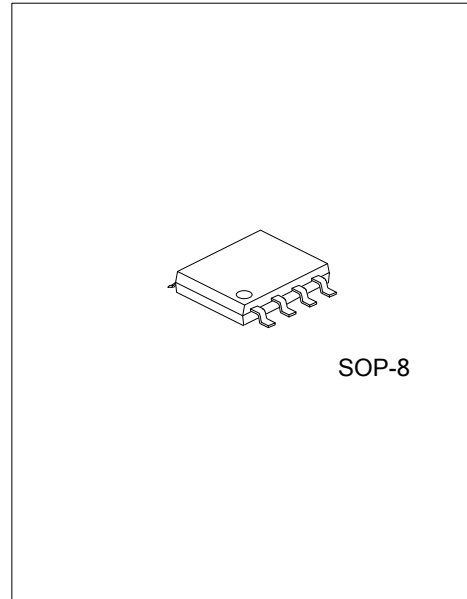

UTT8NP03

Power MOSFET

30V DUAL MIDDLE POWER MOSFET (N-CHANNEL/P-CHANNEL)



■ DESCRIPTION

The UTC **UTT8NP03** is a 30V N-Channel & P-Channel middle Power MOSFET, it uses UTC's advanced technology to provide the customers with a minimum on state resistance, etc.

The UTC **UTT8NP03** is suitable for switching.

■ FEATURES

* N-CHANNEL

$R_{DS(ON)} \leq 30 \text{ m}\Omega @ V_{GS}=10V, I_D=8.0A$

$R_{DS(ON)} \leq 40 \text{ m}\Omega @ V_{GS}=4.5V, I_D=5.0A$

* P-CHANNEL

$R_{DS(ON)} \leq 70 \text{ m}\Omega @ V_{GS}=-10V, I_D=-5.0A$

$R_{DS(ON)} \leq 100 \text{ m}\Omega @ V_{GS}=-4.5V, I_D=-3.0A$

* Low on-resistance

■ SYMBOL

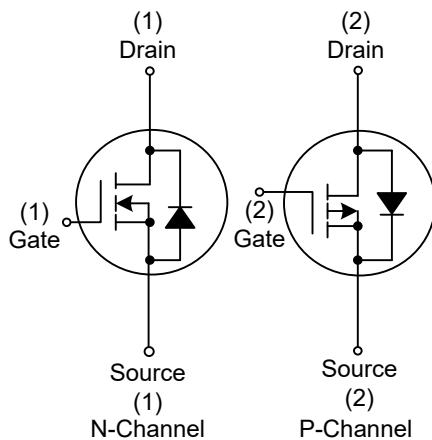

■ ORDERING INFORMATION

Ordering Number		Package	Pin Assignment								Packing
Lead Free	Halogen Free		1	2	3	4	5	6	7	8	
UTT8NP03L-S08-R	UTT8NP03G-S08-R	SOP-8	S1	G1	S2	G2	D2	D2	D1	D1	Tape Reel

Note: Pin Assignment: G: Gate D: Drain S: Source

<p>UTT8NP03G-S08-R</p>	<p>(1) R: Tape Reel</p> <p>(2) S08: SOP-8</p> <p>(3) G: Halogen Free and Lead Free, L: Lead Free</p>
------------------------	--

MARKING

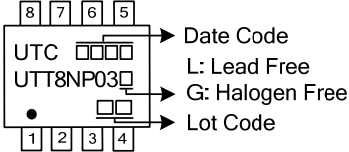

■ ABSOLUTE MAXIMUM RATING ($T_C=25^\circ\text{C}$, unless otherwise specified)

PARAMETER	SYMBOL	RATINGS		UNIT	
		N-CHANNEL	P-CHANNEL		
Drain-Source Voltage	V_{DSS}	30	-30	V	
Gate-Source Voltage	V_{GSS}	± 20	± 20	V	
Drain Current	Continuous	I_D	8	-5	A
	Pulsed (Note 2)	I_{DM}	32	-20	A
Avalanche Energy (Note 3)	Single Pulsed (Note 3)	E_{AS}	6	7	mJ
Peak Diode Recovery dv/dt	dv/dt	1.55 (Note 4)	1.8 (Note 5)	V/ns	
Power Dissipation	P_D	2.5		W	
Junction Temperature	T_J	+150		$^\circ\text{C}$	
Storage Temperature Range	T_{STG}	-55 ~ +150		$^\circ\text{C}$	

Notes: 1. Absolute maximum ratings are those values beyond which the device could be permanently damaged.

Absolute maximum ratings are stress ratings only and functional device operation is not implied.

2. Repetitive Rating: Pulse width limited by maximum junction temperature.

3. (N-CHANNEL) $L=0.1\text{mH}$, $I_{AS}=11\text{A}$, $V_{DD}=25\text{V}$, $R_G=25\Omega$, Starting $T_J=25^\circ\text{C}$.

4. (P-CHANNEL) $L=0.1\text{mH}$, $I_{AS}=-12\text{A}$, $V_{DD}=-25\text{V}$, $R_G=25\Omega$, Starting $T_J=25^\circ\text{C}$.

5. (N-CHANNEL) $I_{SD}\leq 8.0\text{A}$, $di/dt\leq 200\text{A}/\mu\text{s}$, $V_{DD}\leq V_{(BR)DSS}$, $T_J=25^\circ\text{C}$.

6. (P-CHANNEL) $I_{SD}\leq -5.0\text{A}$, $di/dt\leq 200\text{A}/\mu\text{s}$, $V_{DD}\leq V_{(BR)DSS}$, $T_J=25^\circ\text{C}$.

■ THERMAL DATA

PARAMETER	SYMBOL	RATINGS	UNIT
Junction to Ambient	θ_{JA}	62.5	$^\circ\text{C}/\text{W}$
Junction to Case	θ_{JC}	50	$^\circ\text{C}/\text{W}$

Note: The data tested by surface mounted on a 1 inch² FR-4 board with 2OZ copper.

■ ELECTRICAL CHARACTERISTICS ($T_A=25^\circ\text{C}$, unless otherwise specified)

N-CHANNEL

PARAMETER	SYMBOL	TEST CONDITIONS	MIN	TYP	MAX	UNIT
OFF CHARACTERISTICS						
Drain-Source Breakdown Voltage	BV_{DSS}	$I_D=250\mu\text{A}$, $V_{GS}=0\text{V}$	30			V
Zero Gate Voltage Drain Current	I_{DSS}	$V_{DS}=30\text{V}$, $V_{GS}=0\text{V}$			1	μA
Gate-Source Leakage Current	I_{GSS}	$V_{GS}=\pm 20\text{V}$, $V_{DS}=0\text{V}$			± 100	nA
ON CHARACTERISTICS						
Gate Threshold Voltage	$V_{GS(TH)}$	$V_{DS}=V_{GS}$, $I_D=250\mu\text{A}$	1.0		3.0	V
Static Drain-Source On-State Resistance (Pulsed)	$R_{DS(ON)}$	$V_{GS}=10\text{V}$, $I_D=8.0\text{A}$			30	$\text{m}\Omega$
		$V_{GS}=4.5\text{V}$, $I_D=5.0\text{A}$			40	$\text{m}\Omega$
DYNAMIC PARAMETERS						
Input Capacitance	C_{ISS}	$V_{DS}=25\text{V}$, $V_{GS}=0\text{V}$, $f=1.0\text{MHz}$		326		pF
Output Capacitance	C_{OSS}			50		pF
Reverse Transfer Capacitance	C_{RSS}			35		pF
SWITCHING PARAMETERS						
Total Gate Charge (Pulsed)	Q_G	$V_{DS}=24\text{V}$, $V_{GS}=10\text{V}$, $I_D=8.0\text{A}$, $I_G=1\text{mA}$ (Note 1, 2)		12		nC
Gate to Source Charge (Pulsed)	Q_{GS}			2.5		nC
Gate to Drain Charge (Pulsed)	Q_{GD}			2.5		nC
Turn-ON Delay Time (Pulsed)	$t_{D(ON)}$	$V_{DD}=15\text{V}$, $V_{GS}=10\text{V}$, $I_D=8.0\text{A}$, $R_G=25\Omega$ (Note 1, 2)		9		ns
Rise Time (Pulsed)	t_R			8		ns
Turn-OFF Delay Time (Pulsed)	$t_{D(OFF)}$			30		ns
Fall-Time (Pulsed)	t_F			20		ns
SOURCE TO DRAIN DIODE SPECIFICATIONS						
Maximum Body-Diode Continuous Current	I_S				8	A
Maximum Body-Diode Pulsed Current	I_{SM}				12	A
Drain-Source Diode Forward Voltage (Note 1)	V_{SD}	$I_S=1.0\text{A}$, $V_{GS}=0\text{V}$			1.0	V
Reverse Recovery Time (Note 1)	t_{rr}	$I_S=8.0\text{A}$, $V_{GS}=0\text{V}$,		120		nS
Reverse Recovery Charge	Q_{rr}	$dI_F/dt = 100\text{A}/\mu\text{s}$		107		nC

Notes: 1. Pulse Test: Pulse width $\leq 300\mu\text{s}$, Duty cycle $\leq 2\%$.

2. Essentially independent of operating temperature.

■ ELECTRICAL CHARACTERISTICS (Cont.)

P-CHANNEL

PARAMETER	SYMBOL	TEST CONDITIONS	MIN	TYP	MAX	UNIT
OFF CHARACTERISTICS						
Drain-Source Breakdown Voltage	BV_{DSS}	$I_D=-250\mu A, V_{GS}=0V$	-30			V
Zero Gate Voltage Drain Current	I_{DSS}	$V_{DS}=-30V, V_{GS}=0V$			-1	μA
Gate-Source Leakage Current	I_{GSS}	$V_{GS}=\pm 20V, V_{DS}=0V$			± 100	nA
ON CHARACTERISTICS						
Gate Threshold Voltage	$V_{GS(TH)}$	$V_{DS}=V_{GS}, I_D=-250\mu A$	-1.0		-3.0	V
Static Drain-Source On-State Resistance (Pulsed)	$R_{DS(ON)}$	$V_{GS}=-10V, I_D=-5.0A$			70	m Ω
		$V_{GS}=-4.5V, I_D=-3.0A$			100	m Ω
DYNAMIC PARAMETERS						
Input Capacitance	C_{ISS}	$V_{DS}=-15V, V_{GS}=0V, f=1.0MHz$		365		pF
Output Capacitance	C_{OSS}			70		pF
Reverse Transfer Capacitance	C_{RSS}			47		pF
SWITCHING PARAMETERS						
Total Gate Charge (Pulsed)	Q_G	$V_{DD}=-24V, V_{GS}=-10V, I_D=-5.0A$ (Note 1, 2)		12.6		nC
Gate to Source Charge (Pulsed)	Q_{GS}			2.5		nC
Gate to Drain Charge (Pulsed)	Q_{GD}			2.5		nC
Turn-ON Delay Time (Pulsed)	$t_{D(ON)}$	$V_{DD}=-15V, V_{GS}=-10V, I_D=-5.0A,$ $R_G=25\Omega$ (Note 1, 2)		9.0		ns
Rise Time (Pulsed)	t_R			7.5		ns
Turn-OFF Delay Time (Pulsed)	$t_{D(OFF)}$			32		ns
Fall-Time (Pulsed)	t_F			20		ns
SOURCE TO DRAIN DIODE SPECIFICATIONS						
Maximum Body-Diode Continuous Current	I_S				-5	A
Maximum Body-Diode Pulsed Current	I_{SM}				-20	A
Drain-Source Diode Forward Voltage (Note 1)	V_{SD}	$I_S=-1.0A, V_{GS}=0V$			-1	V
Reverse Recovery Time (Note 1)	t_{rr}	$I_S=-5.0A, V_{GS}=0V,$		185		nS
Reverse Recovery Charge	Q_{rr}	$dI_F/dt = 100A/\mu s$		129		nC

Notes: 1. Pulse Test: Pulse width $\leq 300\mu s$, Duty cycle $\leq 2\%$.

2. Essentially independent of operating temperature.

TEST CIRCUITS AND WAVEFORMS

N-CHANNEL

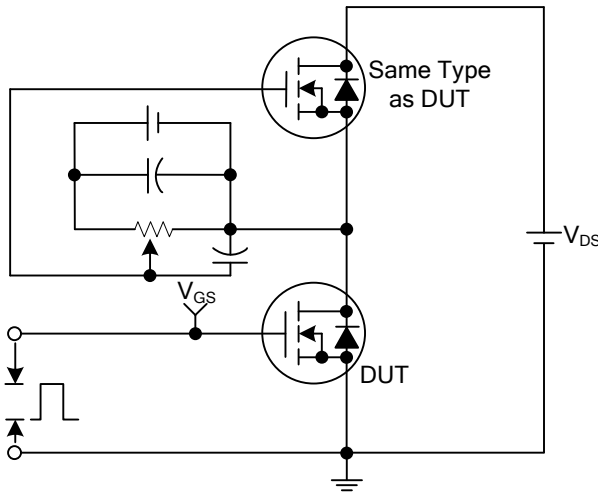

Gate Charge Test Circuit

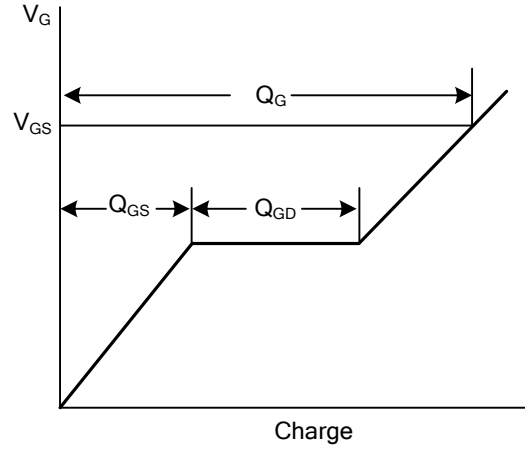

Gate Charge Waveforms

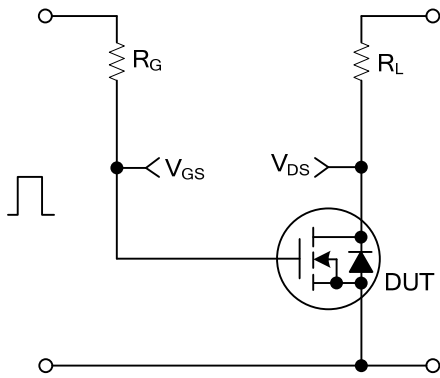

Resistive Switching Test Circuit

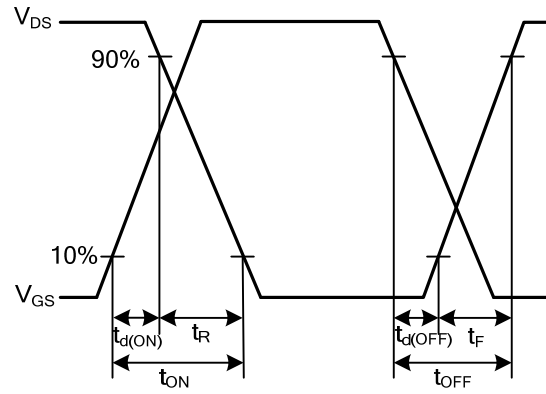

Resistive Switching Waveforms

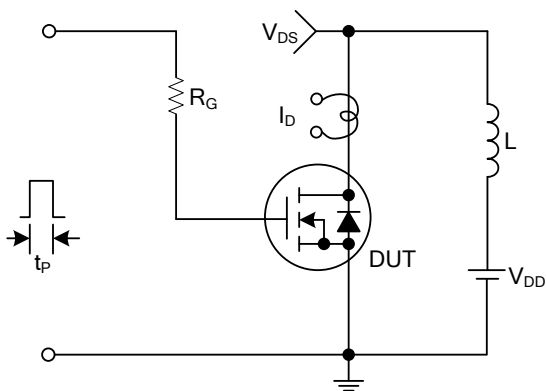

Unclamped Inductive Switching Test Circuit

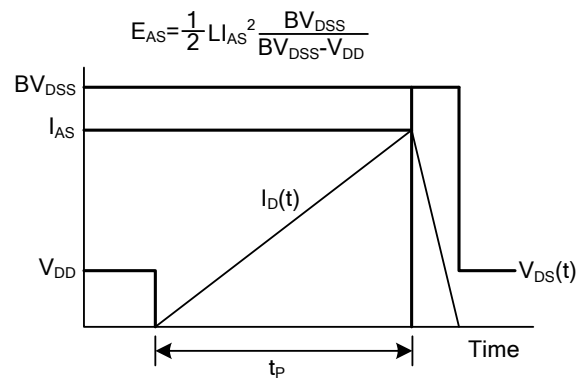

Unclamped Inductive Switching Waveforms

TEST CIRCUITS AND WAVEFORMS (Cont.)

P-CHANNEL

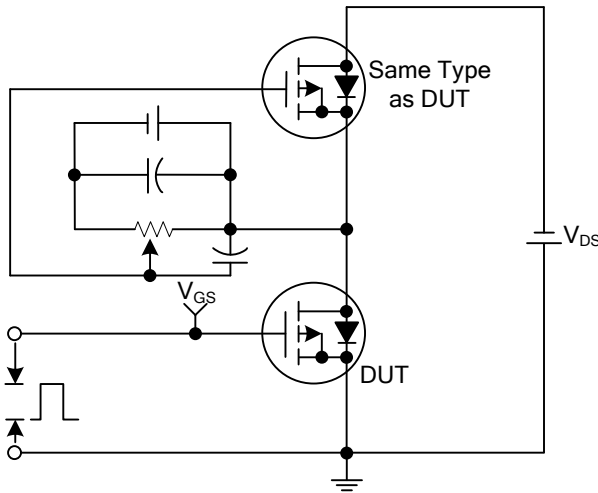

Gate Charge Test Circuit

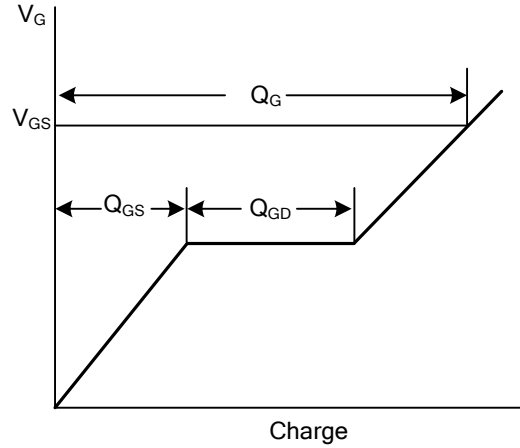

Gate Charge Waveforms

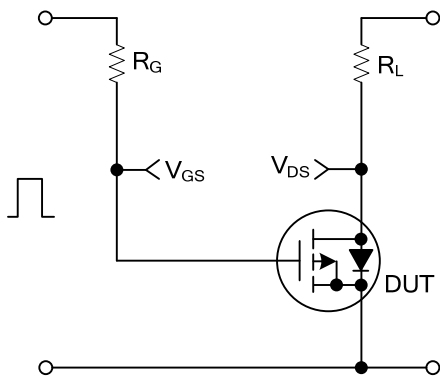

Resistive Switching Test Circuit

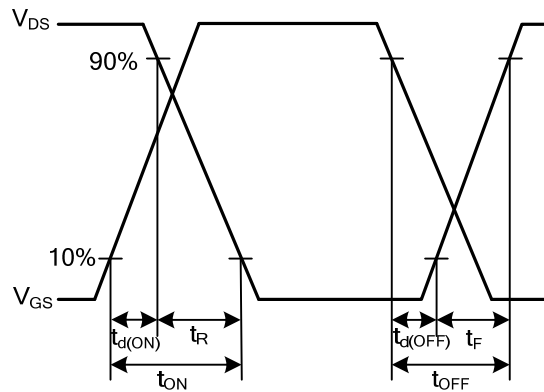

Resistive Switching Waveforms

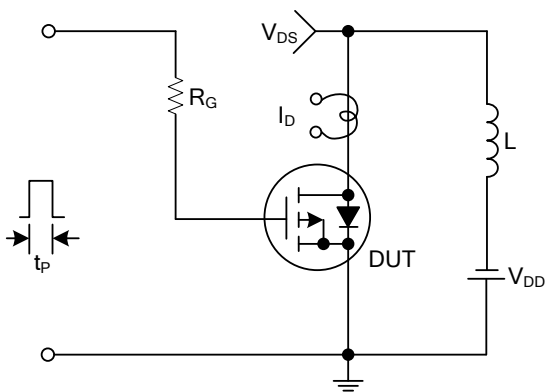

Unclamped Inductive Switching Test Circuit

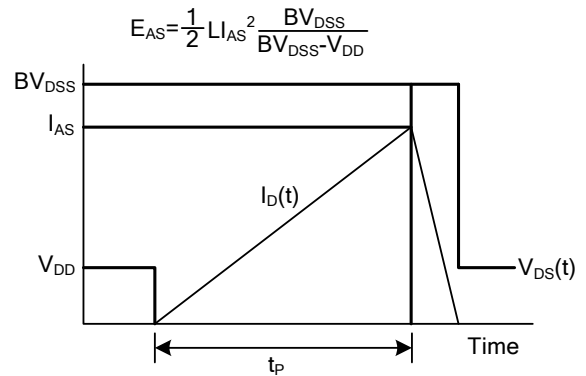

Unclamped Inductive Switching Waveforms

TYPICAL CHARACTERISTICS

N-CHANNEL

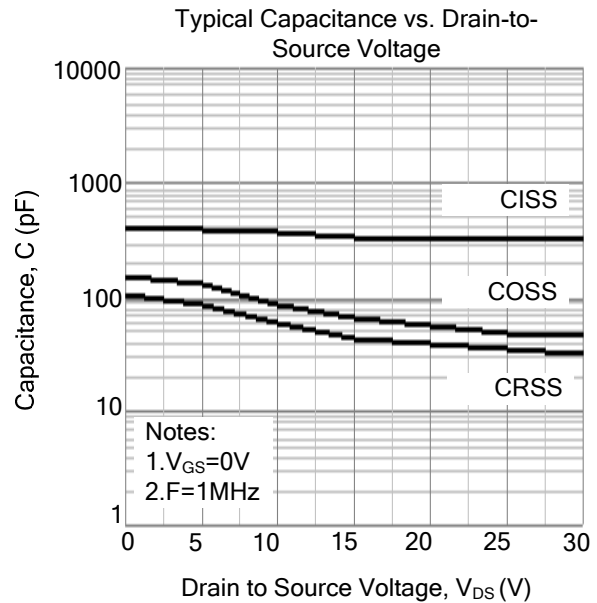
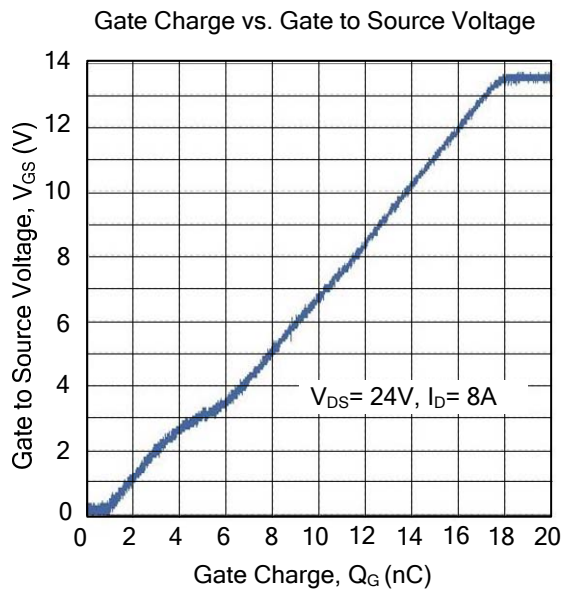

P-CHANNEL

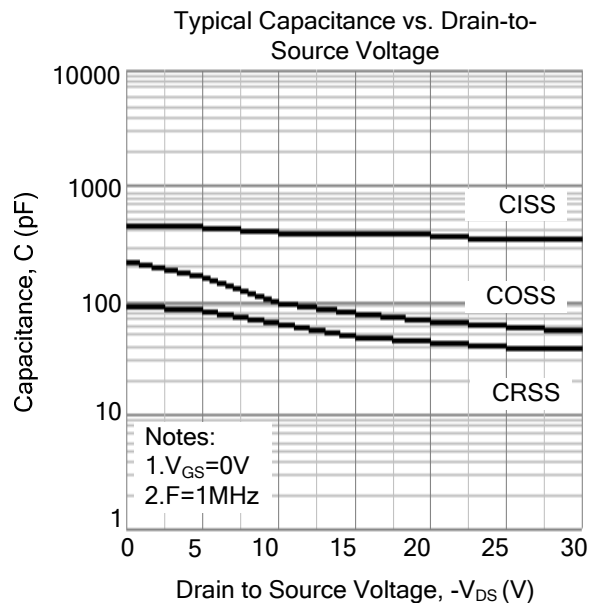
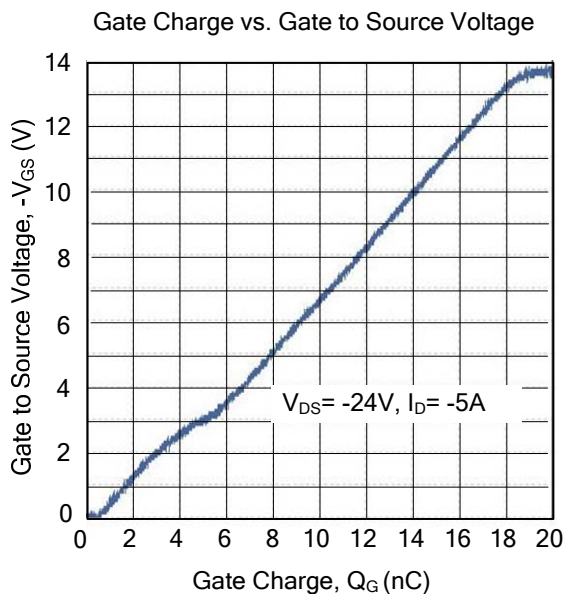

UTC assumes no responsibility for equipment failures that result from using products at values that exceed, even momentarily, rated values (such as maximum ratings, operating condition ranges, or other parameters) listed in products specifications of any and all UTC products described or contained herein. UTC products are not designed for use in life support appliances, devices or systems where malfunction of these products can be reasonably expected to result in personal injury. Reproduction in whole or in part is prohibited without the prior written consent of the copyright owner. UTC reserves the right to make changes to information published in this document, including without limitation specifications and product descriptions, at any time and without notice. This document supersedes and replaces all information supplied prior to the publication hereof.