

Features

- Wide Input Voltage Range:
 - 3 V to 15 V
- Fixed Output Voltage:
 - 1.25 V, 2.048 V, 2.5 V, 3 V, 3.3 V, 4.096 V, 4.5 V, and 5 V
- Low Temperature Coefficient:
 - 1 ppm/°C Typical from 0°C to 70°C
 - 2 ppm/°C Typical from -40°C to 105°C
 - 2.5 ppm/°C Typical from -40°C to 125°C
- High Initial Accuracy:
 - 0.05% Maximum
- Low Noise:
 - 3 μ Vpp/V
- Temperature Range: -40°C to 125°C
- Package Options:
 - SOP8
 - MSOP8

Applications

- Battery Test Equipment
- Industry Control
- Precision Instrumentation
- Medical Equipment

Description

The TPR50 series is a family of high-precision and low-temperature-drift voltage references with an initial accuracy of 0.05% and a temperature coefficient of 2.5 ppm/°C. All products of the TPR50 series are able to support both sinking and sourcing current of ± 10 mA and have a low dropout voltage.

The high precision and excellent temperature stability performance make the TPR50 series an ideal reference in the system with high-resolution requirements.

The TPR50 series provides the 8-pin SOP and MSOP package with a wide range of output voltages. All the products are qualified to operate with the temperature range from -40°C to +125°C.

Typical Application Circuit

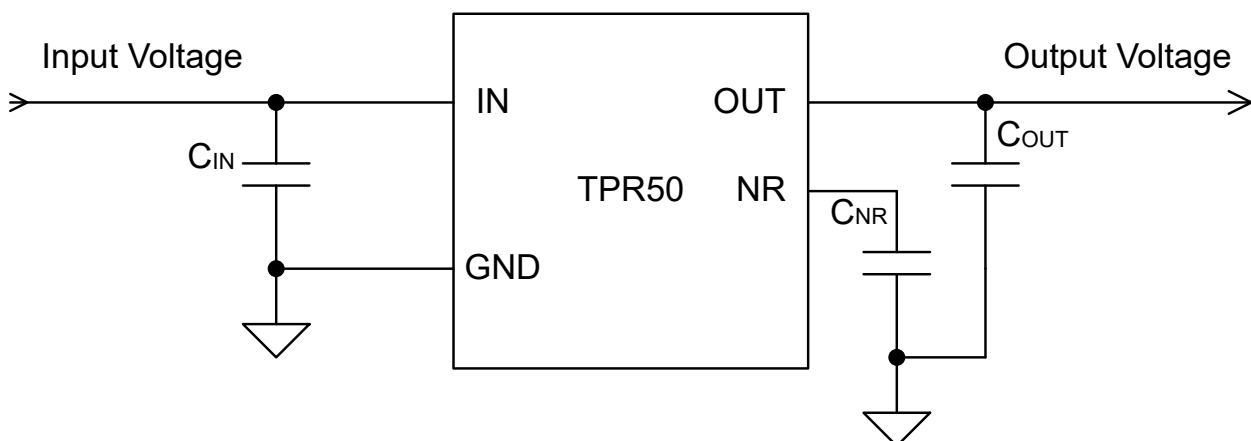

Table of Contents

Features	1
Applications	1
Description	1
Typical Application Circuit	1
Product Family Table	3
Revision History	3
Pin Configuration and Functions	4
Specifications	5
Absolute Maximum Ratings ⁽¹⁾	5
ESD, Electrostatic Discharge Protection.....	5
Recommended Operating Conditions.....	5
Thermal Information.....	5
Electrical Characteristics.....	6
Typical Performance Characteristics.....	8
Detailed Description	11
Overview.....	11
Functional Block Diagram.....	11
Feature Description.....	11
Application and Implementation	13
Application Information	13
Typical Application.....	13
Layout	15
Layout Guideline.....	15
Layout Example.....	15
Tape and Reel Information	16
Package Outline Dimensions	17
SOP8.....	17
MSOP8.....	18
Order Information	19
IMPORTANT NOTICE AND DISCLAIMER	20

Product Family Table

Order Number	Output Voltage	Package
TPR5012-SO1R	1.25 V	SOP8
TPR5020-SO1R	2.048 V	SOP8
TPR5025-SO1R	2.5 V	SOP8
TPR5030-SO1R	3.0 V	SOP8
TPR5033-SO1R	3.3 V	SOP8
TPR5040-SO1R	4.096 V	SOP8
TPR5045-SO1R	4.5 V	SOP8
TPR5050-SO1R	5.0 V	SOP8
TPR5012-VS1R-S	1.25 V	MSOP8
TPR5020-VS1R-S	2.048 V	MSOP8
TPR5025-VS1R-S	2.5 V	MSOP8
TPR5030-VS1R-S	3.0 V	MSOP8
TPR5033-VS1R-S	3.3 V	MSOP8
TPR5040-VS1R-S	4.096 V	MSOP8
TPR5045-VS1R-S	4.5 V	MSOP8
TPR5050-VS1R-S	5.0 V	MSOP8

Revision History

Date	Revision	Notes
2022-08-15	Rev.Pre.0	Preliminary revision.
2023-02-15	Rev.A.0	Initial released.
2023-05-15	Rev.A.1	<ol style="list-style-type: none">Added MSOP8 package products.Updated Thermal Information.Updated Thermal Hysteresis.Updated Capacitive Load condition.
2024-10-10	Rev.A.2	<ol style="list-style-type: none">Added the maximum value of TC (Temperature Coefficient) under the condition of $T_A = 0$ to 70°C in Electrical Characteristics.Added the typical value of LTS (Long-Term Stability) of the SOP8 and MSOP8 packages in Electrical Characteristics.Added the Long-Term Stability waveforms, Figure 11, Figure 12, Figure 13, and Figure 14, in Typical Performance Characteristics.Corrected typos.

Pin Configuration and Functions

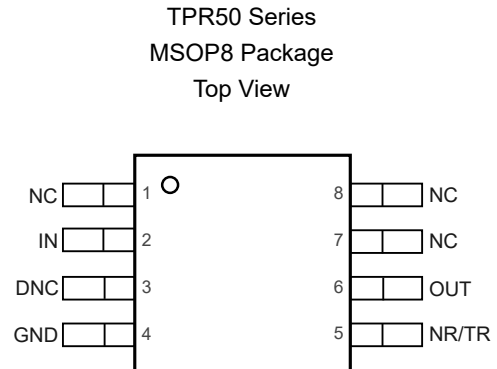
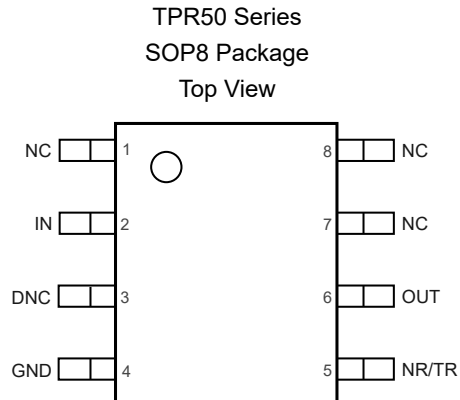

Table 1. Pin Functions: TPR50

Pin Number	Pin Name	I/O	Description
3	DNC	–	Do not connect. Left this pin open or connected to the ground.
4	GND	–	Ground.
2	IN	I	Supply voltage input pin.
1, 7,8	NC	–	No internal connection.
5	NR/TR	I	Noise reduction pin. A 10-nF or larger capacitor from NR to GND (as close as possible to NR pin) is recommended to minimize the output noise level.
6	OUT	O	Reference voltage output pin.

Low-Noise, Low-Drift, Precision Voltage Reference

Specifications

Absolute Maximum Ratings ⁽¹⁾

Parameter		Min	Max	Unit
V _{IN}	Supply Voltage	-0.3	20	V
T _J	Maximum Junction Temperature	-40	150	°C
T _A	Operating Temperature Range	-40	125	°C
T _{STG}	Storage Temperature Range	-65	150	°C
T _L	Lead Temperature (Soldering 10 sec)		260	°C

(1) Stresses beyond those listed under Absolute Maximum Ratings may cause permanent damage to the device. Exposure to any Absolute Maximum Rating condition for extended periods may affect device reliability and lifetime.

(2) All voltage values are with respect to ground.

ESD, Electrostatic Discharge Protection

Parameter		Condition	Minimum Level	Unit
HBM	Human Body Model ESD	ANSI/ESDA/JEDEC JS-001 ⁽¹⁾	±2000	V
CDM	Charged Device Model ESD	ANSI/ESDA/JEDEC JS-002 ⁽²⁾	±1000	V

(1) JEDEC document JEP155 states that 500-V HBM allows safe manufacturing with a standard ESD control process.

(2) JEDEC document JEP157 states that 250-V CDM allows safe manufacturing with a standard ESD control process.

Recommended Operating Conditions

Parameter		Min	Typ	Max	Unit
V _{IN}		3		15	V
I _{OUT}		-10		10	mA
C _{OUT}		0.1	10	100	μF
T _J	Junction Temperature Range	-40		125	°C

Thermal Information

Package Type	θ _{JA}	θ _{JC,top}	θ _{JB}	θ _{JC,bottom}	Unit
SOP8	115.2	60.8	61.1	64.2	°C/W
MSOP8	138.0	54.6	84.5	88.1	°C/W

Low-Noise, Low-Drift, Precision Voltage Reference
Electrical Characteristics

All test conditions: at $T_A = 25^\circ\text{C}$. $V_{IN} = V_{OUT(NOM)} + 0.5\text{ V}$ or 5 V , whichever is greater, $C_{OUT} = 1\ \mu\text{F}$, unless otherwise noted.

Parameter	Conditions	Min	Typ	Max	Unit		
Output Voltage							
V_{OUT}	Output Voltage	TPR5012		1.25		V	
		TPR5020		2.048		V	
		TPR5025		2.5		V	
		TPR5030		3		V	
		TPR5033		3.3		V	
		TPR5040		4.096		V	
		TPR5045		4.5		V	
		TPR5050		5		V	
	Initial Accuracy		-0.05%		+0.05%		
Output Noise	$f = 0.1\text{ Hz to }10\text{ Hz}$		3		$\mu\text{V}_{PP}/\text{V}$		
Input Voltage and Current							
V_{IN}	Input Voltage		$V_{IN,MIN}^{(1)}$	15	V		
I_Q	Quiescent Current	$T_A = -40^\circ\text{C to }125^\circ\text{C}$		0.6	1	mA	
Dropout Voltage							
V_{DO}	Dropout Voltage ⁽²⁾	$I_{OUT} = \pm 5\text{ mA}$, $T_A = -40^\circ\text{C to }125^\circ\text{C}$			200	mV	
		$I_{OUT} = \pm 10\text{ mA}$, $T_A = -40^\circ\text{C to }125^\circ\text{C}$			400	mV	
Output Voltage Temperature Drift							
TC	Temperature Coefficient	$T_A = 0\text{ to }70^\circ\text{C}^{(3)}$		1	3	ppm/ $^\circ\text{C}$	
		$T_A = -40^\circ\text{C to }105^\circ\text{C}$		2	5	ppm/ $^\circ\text{C}$	
		$T_A = -40^\circ\text{C to }125^\circ\text{C}$		2.5	6	ppm/ $^\circ\text{C}$	
Output Regulation							
$\frac{\Delta V_{OUT}}{\Delta V_{IN}}$	Line Regulation	$V_{IN} = V_{IN,MIN}$ to 15 V , $T_A = -40^\circ\text{C to }125^\circ\text{C}$		0.1		ppm/V	
		$V_{IN} = 6\text{ V to }15\text{ V}$, $T_A = -40^\circ\text{C to }125^\circ\text{C}$		0.1		ppm/V	
		$V_{IN} = V_{IN,MIN}$ to 6 V , $V_{OUT} = 1.25\text{ V}$, 2.048 V , 2.5 V and 3 V , $T_A = -40^\circ\text{C to }125^\circ\text{C}$			20		ppm/V
		$V_{IN} = V_{IN,MIN}$ to 6 V , $V_{OUT} = 3.3\text{ V}$ and 4.096 V , $T_A = -40^\circ\text{C to }125^\circ\text{C}$			25		ppm/V
$\frac{\Delta V_{OUT}}{\Delta I_{OUT}}$	Load Regulation	$V_{IN} = V_{IN,MIN}$, $-10\text{ mA} < I_{OUT} < 10\text{ mA}$		2.5	20	ppm/mA	
		$V_{IN} = V_{IN,MIN}$, $-10\text{ mA} < I_{OUT} < 10\text{ mA}$, $T_A = -40^\circ\text{C to }125^\circ\text{C}$		2.5	20	ppm/mA	

Low-Noise, Low-Drift, Precision Voltage Reference

Parameter		Conditions	Min	Typ	Max	Unit
Thermal Hysteresis						
THYS	Thermal Hysteresis	Cycle 1 (+25°C to +125°C to -40°C to 25 °C)		99		ppm
		Cycle 2 (+25°C to +125°C to -40°C to 25 °C)		29		ppm
		Cycle 1 (+25°C to +70°C to 0°C to 25 °C)		56		ppm
		Cycle 2 (+25°C to +70°C to 0°C to 25 °C)		11		ppm
Long-Term Stability						
LTS	Long-Term Stability	0 to 1000 hours, SOP8 Package		30		ppm
		0 to 2000 hours, SOP8 Package		30		ppm
		0 to 1000 hours, MSOP8 Package		60		ppm
		0 to 2000 hours, MSOP8 Package		90		ppm
Turn-On Settling Time						
t _{ON}	Turn-on Settling Time	To 0.1% with CL = 1 μF		150		μs
Short-Circuit Current						
I _{SC}	Short-Circuit Current	V _{OUT} = 0 V		121		mA
Capacitive Load						
C _L			0.1		100	μF

(1) $V_{IN, MIN} = V_{OUT(NOM)} + 0.4 V$ or 3 V, whichever is greater.

(2) Dropout voltage is not tested for the output voltage below 3 V.

(3) Not subject to production test, specified by design.

Typical Performance Characteristics

All test conditions: $V_{IN} = V_{OUT(NOM)} + 0.5\text{ V}$ or 3 V , whichever is greater; $I_{OUT} = 0\text{ mA}$, $C_{IN} = C_{OUT} = 1\text{ }\mu\text{F}$, $T_J = 25^\circ\text{C}$, unless otherwise noted.

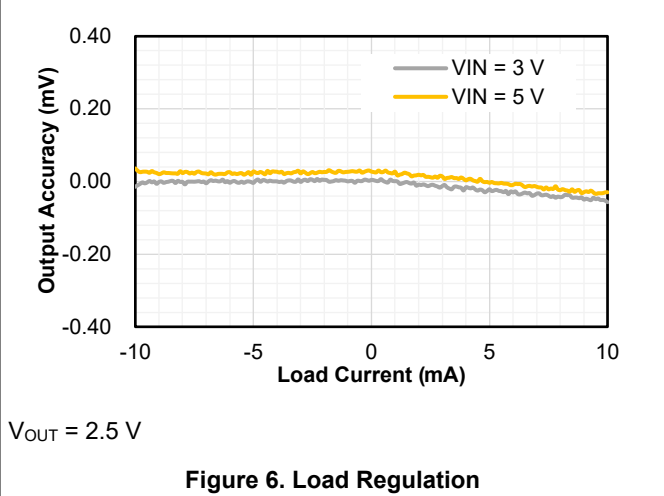
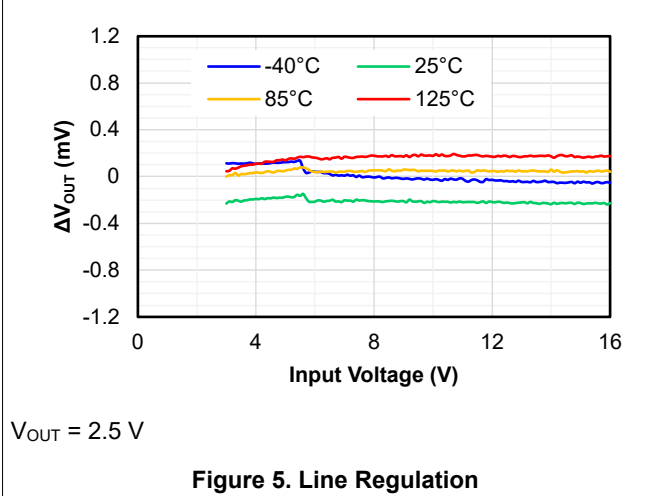
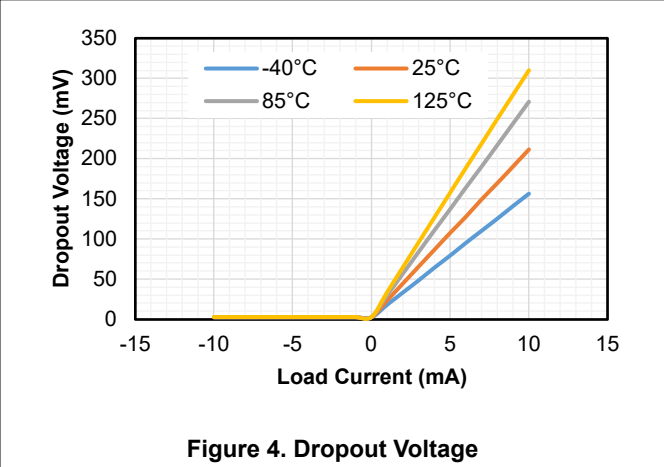
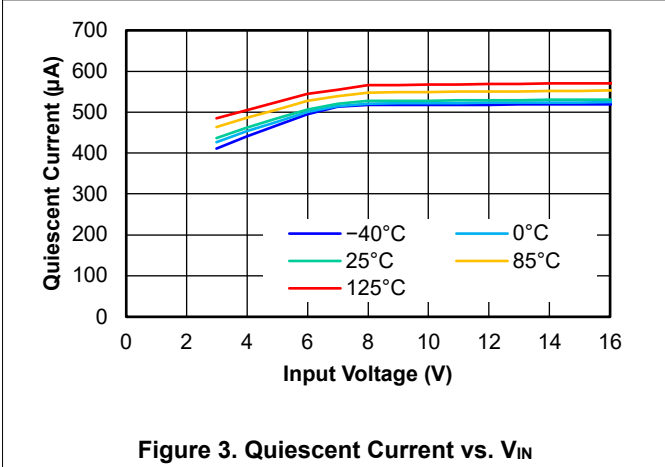
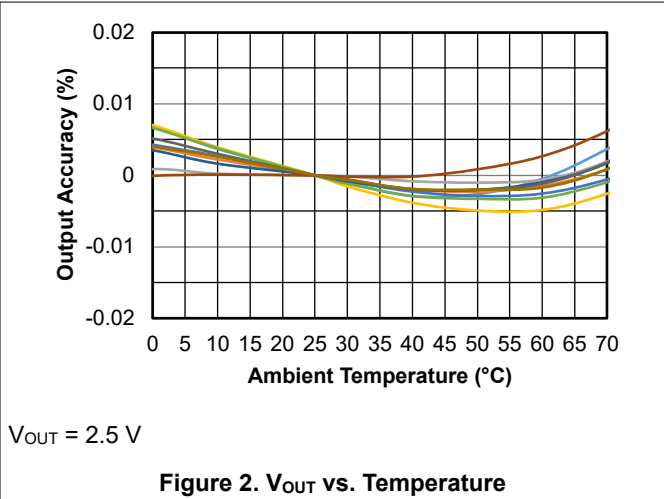
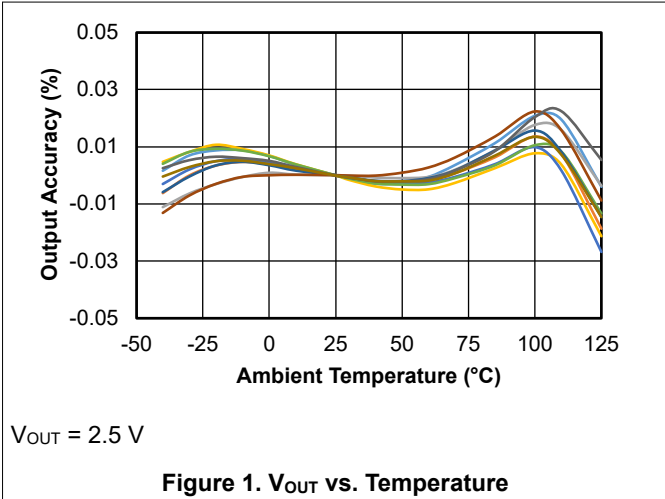

Low-Noise, Low-Drift, Precision Voltage Reference

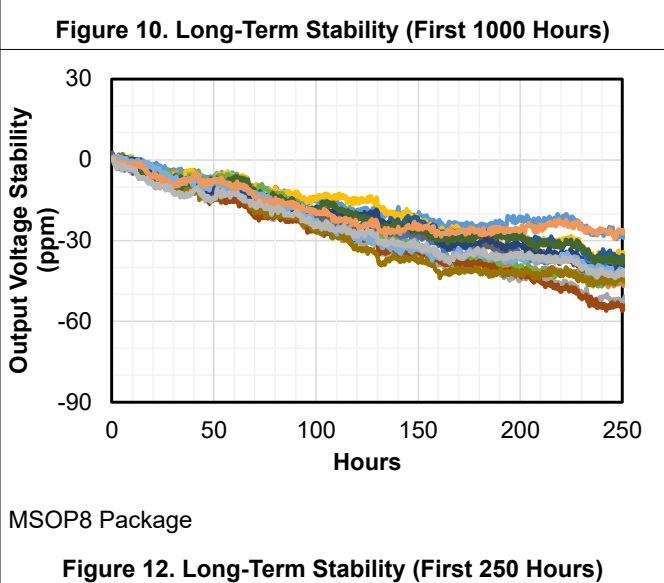
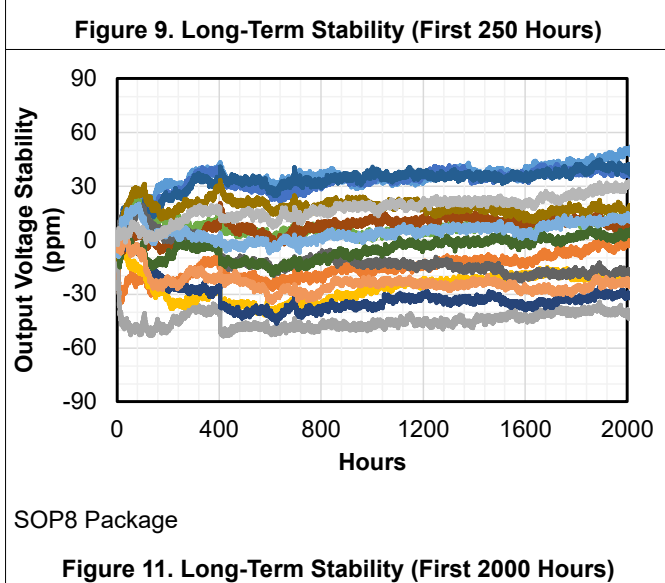
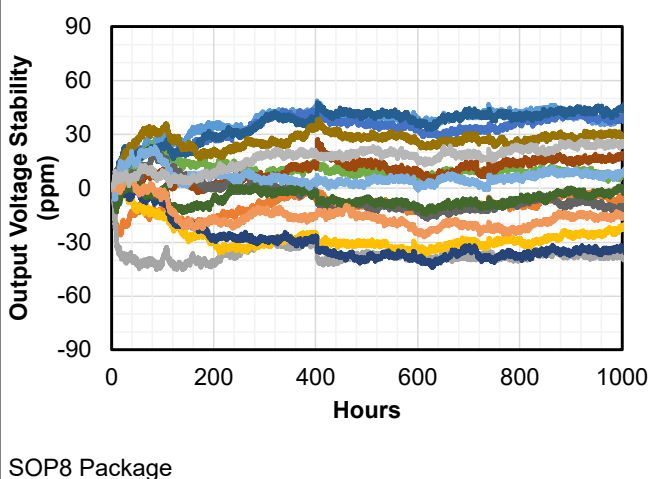
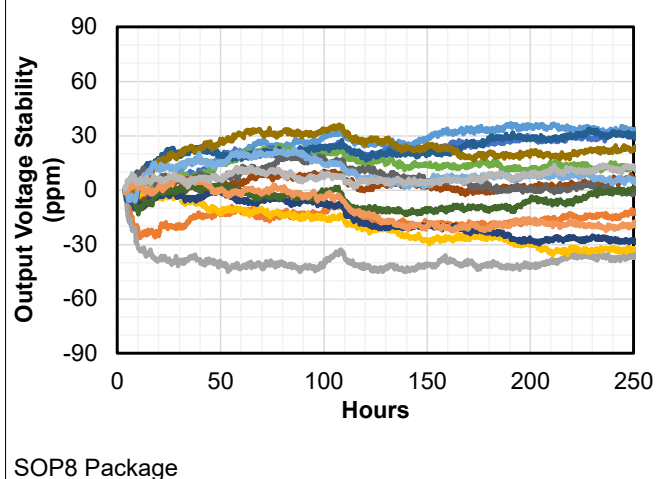
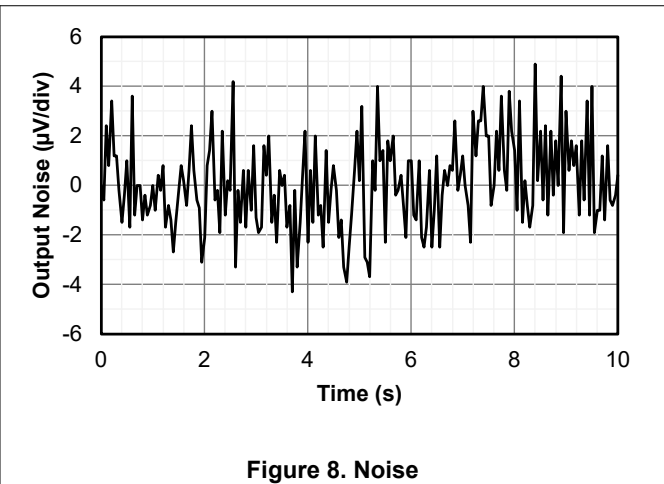
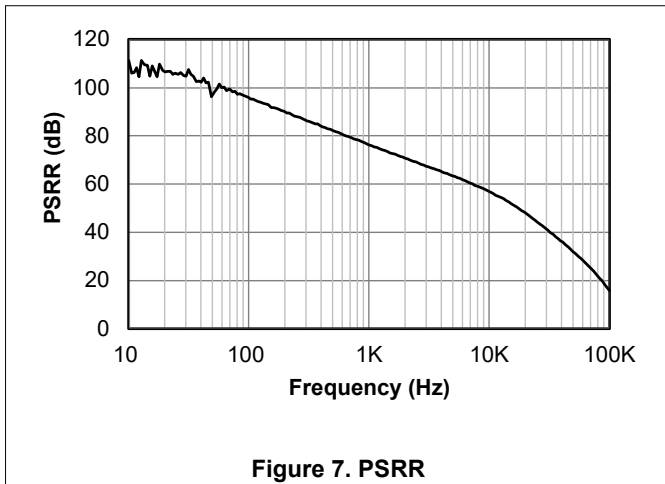

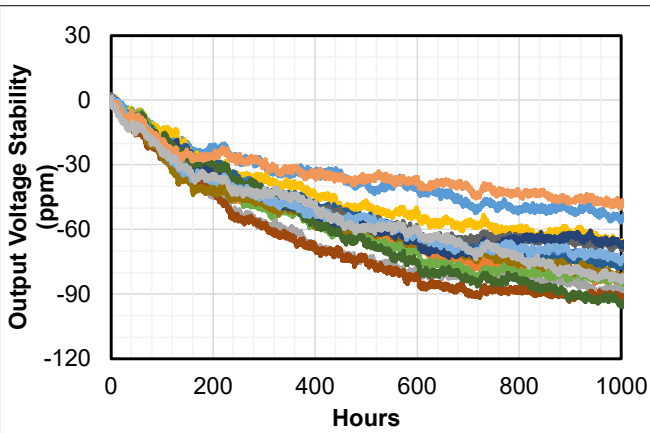

MSOP8 Package

Figure 13. Long-Term Stability (First 1000 Hours)

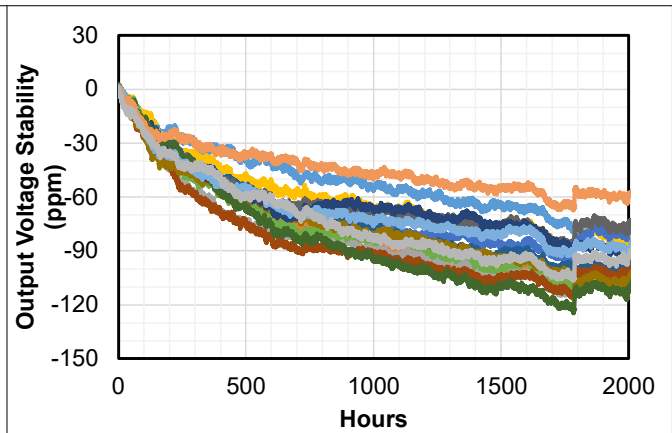

MSOP8 Package

Figure 14. Long-Term Stability (First 2000 Hours)

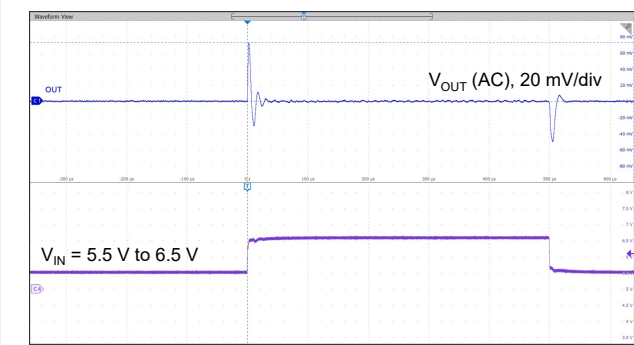

V_{IN} = 5.5 V to 6.5 V, C_{OUT} = 1 µF

Figure 15. Line Transient

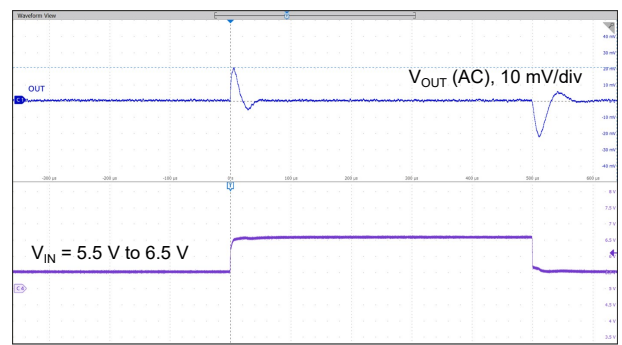

V_{IN} = 5.5 V to 6.5 V, C_{OUT} = 10 µF

Figure 16. Line Transient

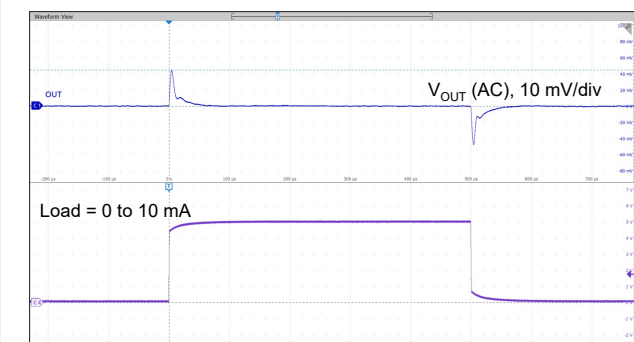

Load = 0 to 10 mA, C_{OUT} = 1 µF

Figure 17. Load Transient

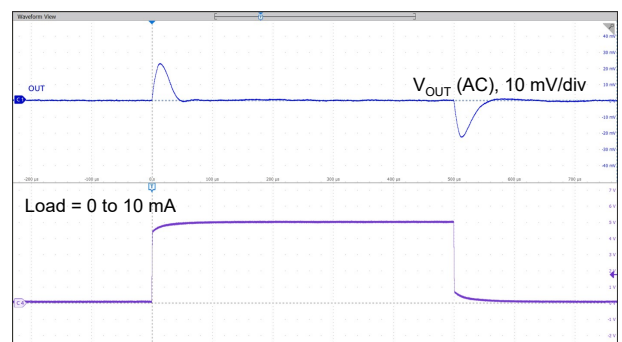

Load = 0 to 10 mA, C_{OUT} = 10 µF

Figure 18. Load Transient

Detailed Description

Overview

The TPR50 series is a family of high-precision and low-temperature-drift voltage references with 0.05% initial accuracy and 2.5 ppm/°C temperature coefficient. All products of the TPR50 series are able to support both sinking and sourcing currents of ±10 mA and have a low dropout voltage.

The high precision and excellent temperature stability performance make the TPR50 series an ideal reference in the system with high-resolution requirements.

Functional Block Diagram

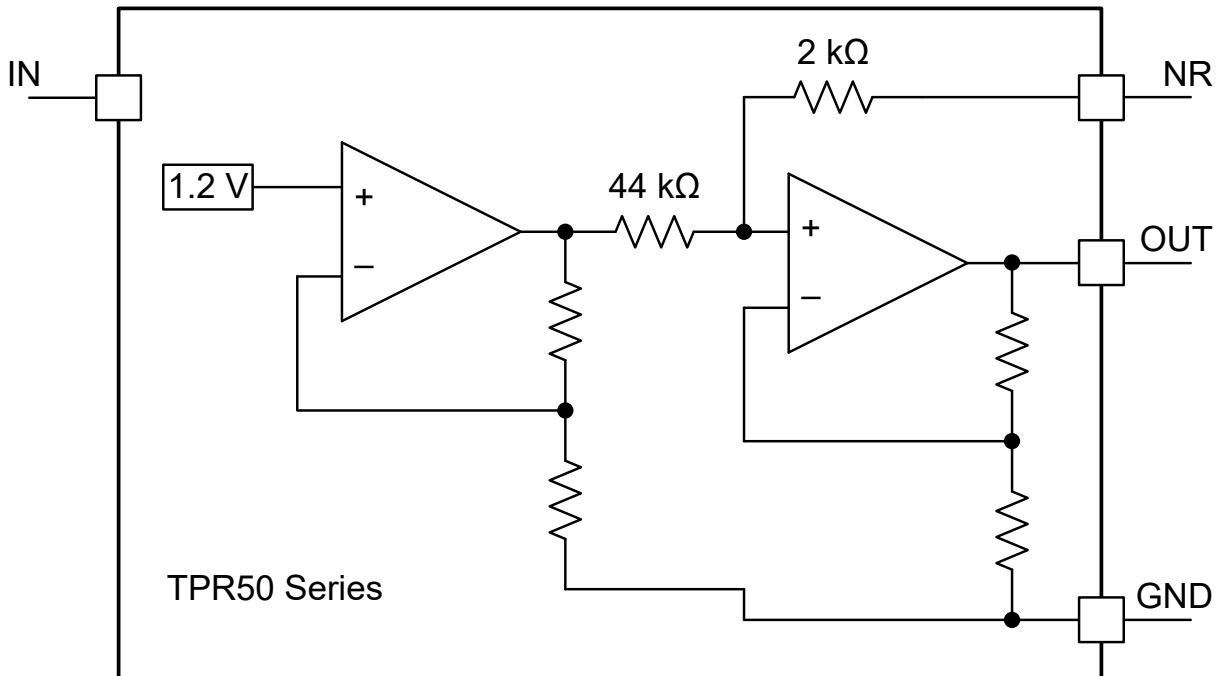

Figure 19. Functional Block Diagram

Feature Description

Temperature Drift

The TPR50 is one of the low-temperature-drift voltage references. Temperature drift is defined as the voltage variation over the operating temperature change, which can be calculated as [Equation 1](#).

$$\text{Temperature Drift} = \left(\frac{V_{\text{OUT,max}} - V_{\text{OUT,min}}}{V_{\text{OUT}}} \right) / (T_{\text{max}} - T_{\text{min}}) \times 10^6 \text{ (ppm/°C)} \quad (1)$$

Where, $V_{\text{OUT,max}}$ and $V_{\text{OUT,min}}$ are the maximum and minimum voltage values during the temperature change, T_{max} and T_{min} are the temperature range, and V_{OUT} is the nominal output voltage.

The maximum temperature drift of TPR50 is 6 ppm/°C from -40°C to 125°C.

Thermal Hysteresis

Thermal hysteresis is defined as the voltage change after the operating temperature cycling, which can be calculated as [Equation 2](#).

$$\text{Thermal Hysteresis} = \frac{|V_{\text{PRE}} - V_{\text{POST}}|}{V_{\text{OUT}}} \times 10^6 \text{ (ppm)} \quad (2)$$

Where, V_{PRE} is the output voltage before the temperature cycling and V_{POST} is the output voltage after the temperature cycling, V_{OUT} is the nominal output voltage.

Noise Reduction

The TPR50 features a low output noise voltage with a typical value of $8 \mu\text{V}_{\text{PP}}$ at $V_{\text{NOM}} = 2.5 \text{ V}$ under room temperature. The noise voltage is proportional to the output voltage and the operating temperature. The noise reduction (NR) pin provides additional filtering to reduce the output noise further, and it is recommended to connect a 10-nF or greater capacitor from the NR pin to ground.

Output Voltage Adjustment

The TPR50 provides a series of fixed output voltages with very high accuracy. Also, the TPR50 provides an NR/TR pin to trim the output voltage with external resistor dividers. [Figure 20](#) shows a typical application circuit to adjust the output voltage.

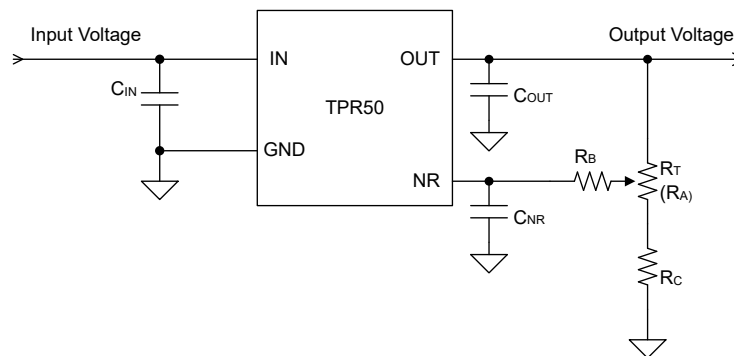

Figure 20. Output Voltage Trim with NR/TR Pin

[Table 2](#) shows an example of 2.5-V output voltage adjustment.

Table 2. Output Voltage Trim Example of 2.5 V

R_T (k Ω)	R_A (k Ω)	R_B (k Ω)	R_C (k Ω)	$V_{\text{OUT,TROM}}$ (V)
10	0	470	1	2.3249
	1			2.3619
	4.5			2.5000
	5.08			2.5244
	9			2.7036
	10			2.7540

(1) R_T is the total value of the rheostat, and R_A is the low-side value of the rheostat.

Application and Implementation

Note

Information in the following application sections is not part of the 3PEAK's component specification and 3PEAK does not warrant its accuracy or completeness. 3PEAK's customers are responsible for determining suitability of components for their purposes. Customers should validate and test their design implementation to confirm system functionality.

Application Information

The TPR50 series is a family of high-precision and low-temperature-drift voltage references with 0.05% initial accuracy and 2.5 ppm/°C temperature coefficient. All products of the TPR50 series are able to support both sinking and sourcing currents of ±10 mA and have a low dropout voltage.

Typical Application

Figure 21 shows the typical application schematic.

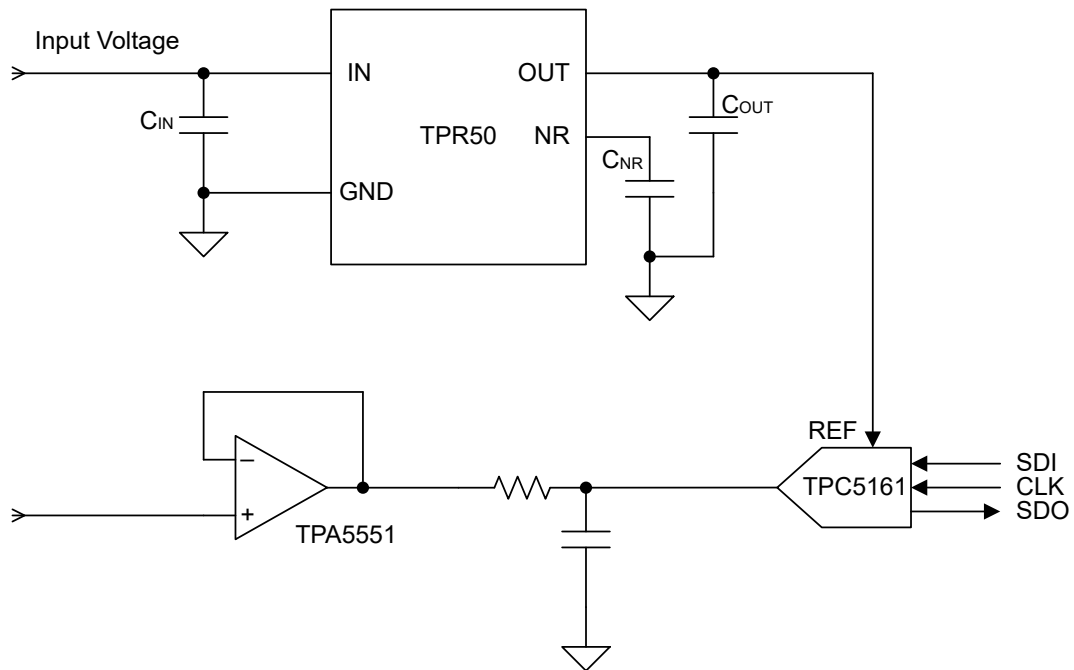

Figure 21. Typical Application Circuit

Power Dissipation and Thermal Consideration

During normal operation, the device junction temperature should meet the requirement in the [Recommended Operating Conditions](#) table. Use below equations to calculate the power dissipation and estimate the junction temperature.

The power dissipation can be calculated using [Equation 3](#).

Low-Noise, Low-Drift, Precision Voltage Reference

$$P_D = (V_{IN} - V_{OUT}) \times I_{OUT} + V_{IN} \times I_Q \quad (3)$$

The junction temperature can be estimated using [Equation 4](#). θ_{JA} is the junction-to-ambient thermal resistance.

$$T_J = T_A + P_D \times \theta_{JA} \quad (4)$$

Layout

Layout Guideline

- Both input capacitors and output capacitors must be placed as close to the device pins as possible.
- It is recommended to bypass the IN pin to ground with a 1- μ F to 10- μ F capacitor in parallel with a 0.1- μ F small ceramic capacitor. The loop area formed by the bypass capacitor connection, the IN pin, and the GND pin of the system must be as small as possible.
- It is required to place a decoupling 1- μ F to 50- μ F capacitor at the output. A small 1- μ F ceramic capacitor in parallel is recommended to filter the noise and improve the output transient performance.

Layout Example

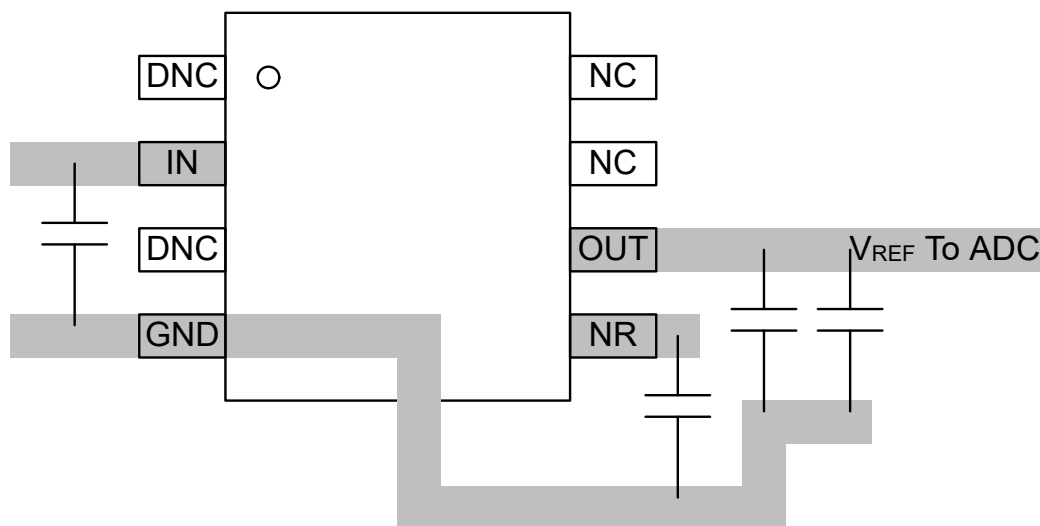
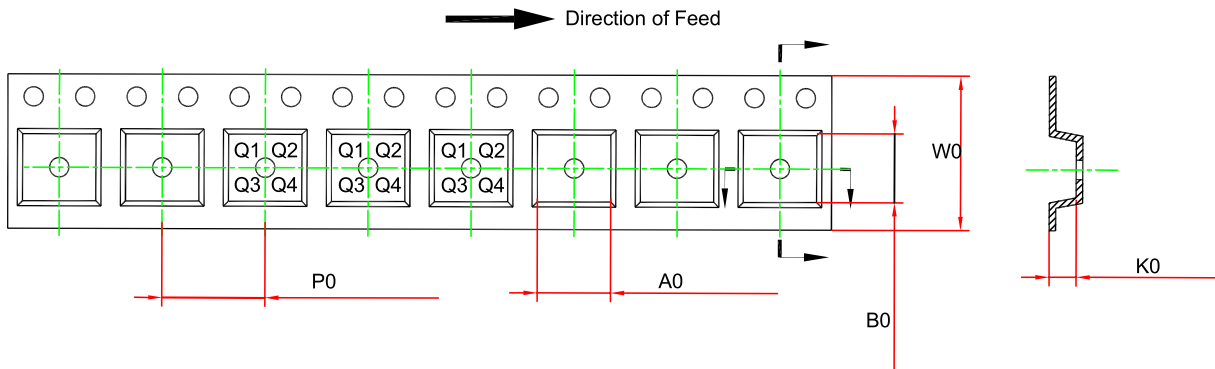
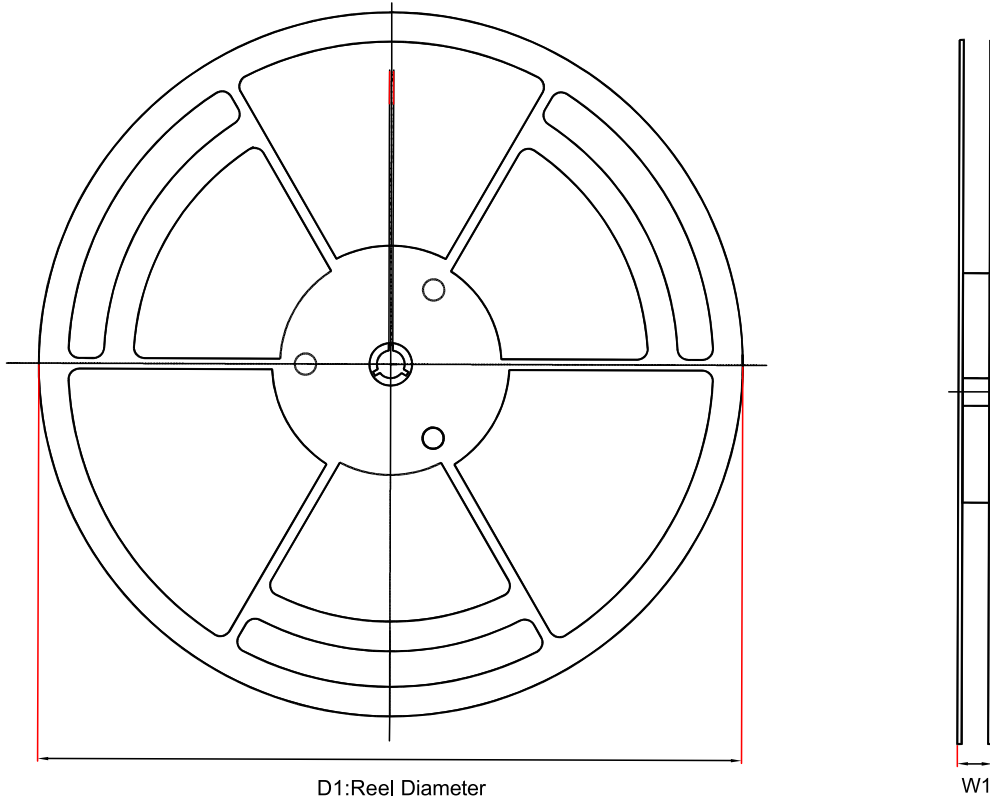

Figure 22. Layout Example

Tape and Reel Information



Order Number	Package	D1 (mm)	W1 (mm)	A0 (mm)	B0 (mm)	K0 (mm)	P0 (mm)	W0 (mm)	Pin1 Quadrant
TPR50xx-SO1R ⁽¹⁾	SOP8	330	17.6	6.4	5.4	2.1	8	12	Q1
TPR50xx-VS1R-S ⁽¹⁾	MSOP8	330	17.6	5.2	3.3	1.5	8	12	Q1

(1) Output voltage value, xx = 12 to 50. For example, 25 means an output voltage of 2.5 V.

Package Outline Dimensions

SOP8

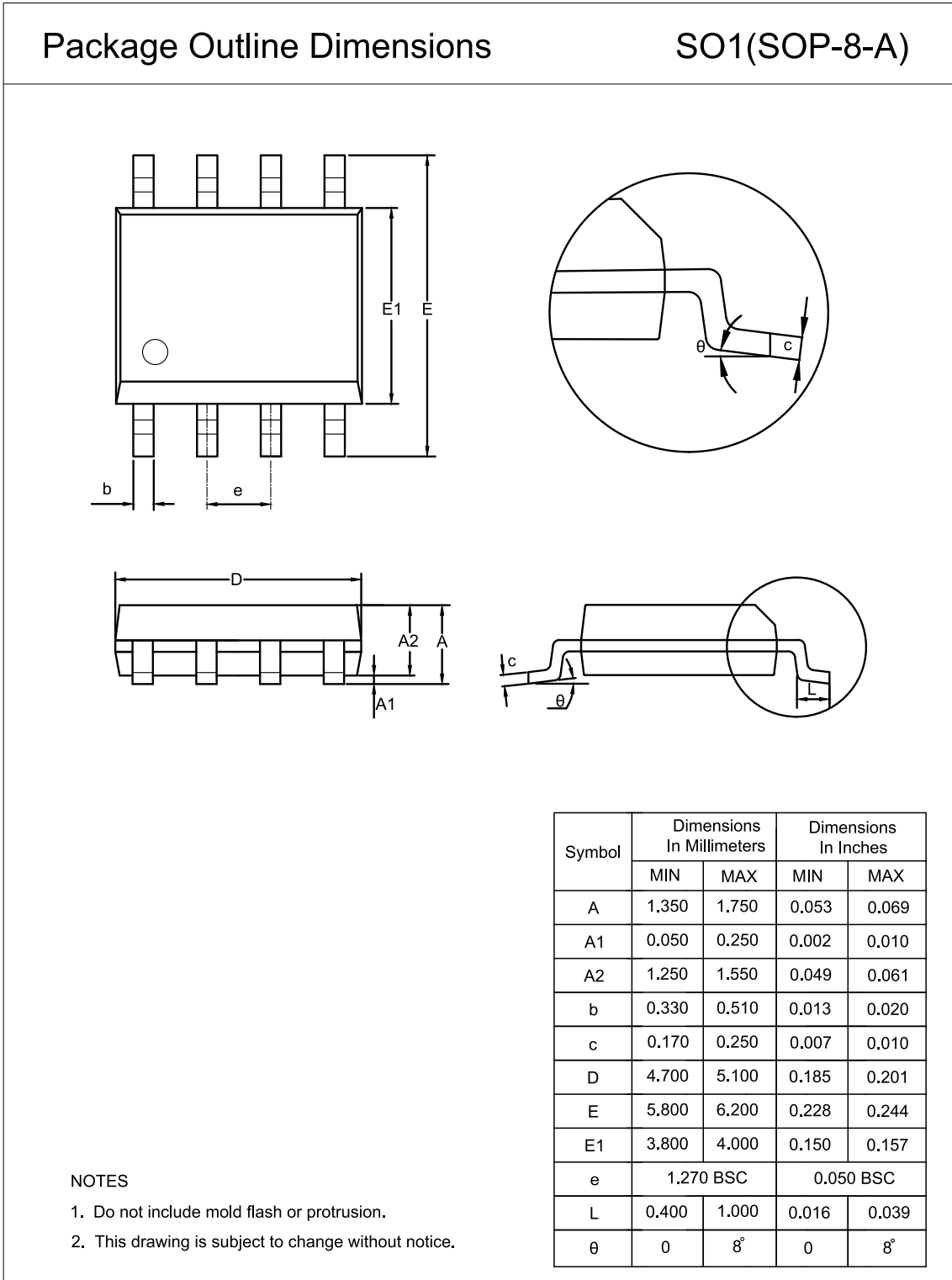

MSOP8

Package Outline Dimensions

VS1(MSOP-8-A)

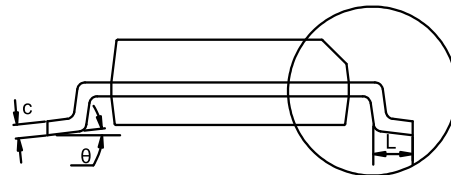
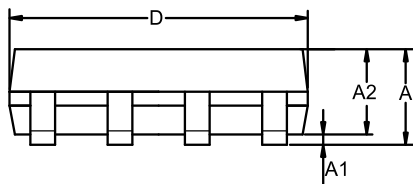
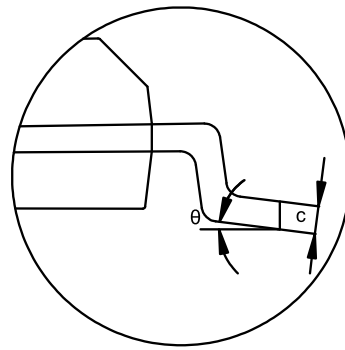
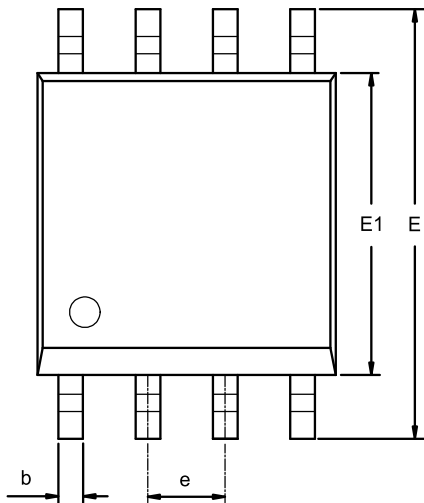

Symbol	Dimensions In Millimeters		Dimensions In Inches	
	MIN	MAX	MIN	MAX
A	0.800	1.100	0.031	0.043
A1	0.020	0.150	0.001	0.006
A2	0.750	0.950	0.030	0.037
b	0.250	0.380	0.010	0.015
c	0.090	0.230	0.004	0.009
D	2.900	3.100	0.114	0.122
E	4.700	5.100	0.185	0.201
E1	2.900	3.100	0.114	0.122
e	0.650 BSC		0.026 BSC	
L	0.400	0.800	0.016	0.031
θ	0	8°	0	8°

NOTES

1. Do not include mold flash or protrusion.
2. This drawing is subject to change without notice.

Order Information

Order Number	Operating Temperature Range	Package	Marking Information	MSL	Transport Media, Quantity	Eco Plan
TPR5012-SO1R	-40°C to +125°C	SOP8	R5A	MSL3	4,000	Green
TPR5020-SO1R	-40°C to +125°C	SOP8	R5B	MSL3	4,000	Green
TPR5025-SO1R	-40°C to +125°C	SOP8	R5C	MSL3	4,000	Green
TPR5030-SO1R	-40°C to +125°C	SOP8	R5D	MSL3	4,000	Green
TPR5033-SO1R	-40°C to +125°C	SOP8	R5E	MSL3	4,000	Green
TPR5040-SO1R	-40°C to +125°C	SOP8	R5F	MSL3	4,000	Green
TPR5045-SO1R	-40°C to +125°C	SOP8	R5H	MSL3	4,000	Green
TPR5050-SO1R	-40°C to +125°C	SOP8	R5G	MSL3	4,000	Green
TPR5012-VS1R-S	-40°C to +125°C	MSOP8	R5A	MSL3	3,000	Green
TPR5020-VS1R-S	-40°C to +125°C	MSOP8	R5B	MSL3	3,000	Green
TPR5025-VS1R-S	-40°C to +125°C	MSOP8	R5C	MSL3	3,000	Green
TPR5030-VS1R-S	-40°C to +125°C	MSOP8	R5D	MSL3	3,000	Green
TPR5033-VS1R-S	-40°C to +125°C	MSOP8	R5E	MSL3	3,000	Green
TPR5040-VS1R-S	-40°C to +125°C	MSOP8	R5F	MSL3	3,000	Green
TPR5045-VS1R-S	-40°C to +125°C	MSOP8	R5H	MSL3	3,000	Green
TPR5050-VS1R-S	-40°C to +125°C	MSOP8	R5G	MSL3	3,000	Green

Green: 3PEAK defines "Green" to mean RoHS compatible and free of halogen substances.

IMPORTANT NOTICE AND DISCLAIMER

Copyright© 3PEAK 2012-2024. All rights reserved.

Trademarks. Any of the 思瑞浦 or 3PEAK trade names, trademarks, graphic marks, and domain names contained in this document /material are the property of 3PEAK. You may NOT reproduce, modify, publish, transmit or distribute any Trademark without the prior written consent of 3PEAK.

Performance Information. Performance tests or performance range contained in this document/material are either results of design simulation or actual tests conducted under designated testing environment. Any variation in testing environment or simulation environment, including but not limited to testing method, testing process or testing temperature, may affect actual performance of the product.

Disclaimer. 3PEAK provides technical and reliability data (including data sheets), design resources (including reference designs), application or other design recommendations, networking tools, security information and other resources "As Is". 3PEAK makes no warranty as to the absence of defects, and makes no warranties of any kind, express or implied, including without limitation, implied warranties as to merchantability, fitness for a particular purpose or non-infringement of any third-party's intellectual property rights. Unless otherwise specified in writing, products supplied by 3PEAK are not designed to be used in any life-threatening scenarios, including critical medical applications, automotive safety-critical systems, aviation, aerospace, or any situations where failure could result in bodily harm, loss of life, or significant property damage. 3PEAK disclaims all liability for any such unauthorized use.