

### Product Overview

The QPQ1237 is a high performance Bulk Acoustic Wave (BAW) Duplexer designed for Band 3 uplink and Band 7 uplink applications.

The QPQ1237 provides low insertion loss and high rejection, making it an ideal choice for Small Cells. This duplexer is housed in a compact, RoHs compliant 3.00 mm x 3.00 mm x 0.91 surface mount package (SMP).

The QPQ1237 is part of Qorvo's extensive portfolio of RF BAW and SAW filters.

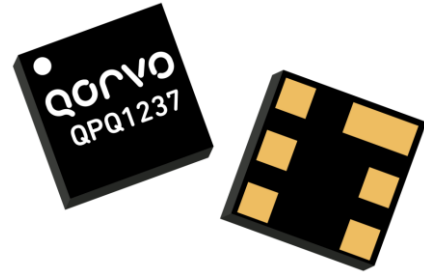

6 Pad 3.00 mm x 3.00 mm x 0.91 mm SMP

### Functional Block Diagram

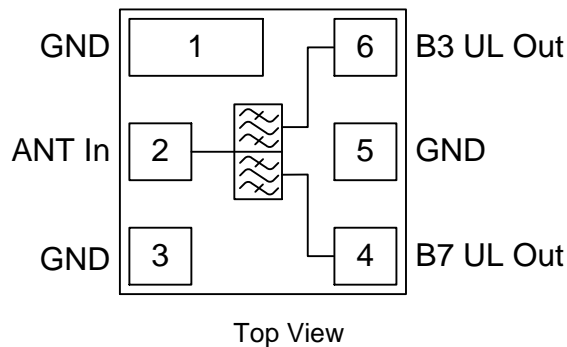

### Pin Configuration

Pin No.	Label
1, 3, 5	Ground
2	ANT In
4	Band 7 Uplink Out
6	Band 3 Uplink Out

### Key Features

- 75 MHz Bandwidth – Band 3 UL
- 70 MHz Bandwidth – Band 7 UL
- High Attenuation
- Low Loss
- No External Matching Required
- Single Input, Dual Output Operation
- Small Size: 3.00 mm x 3.00 mm x 0.91 mm
- Surface Mount Package (SMP)
- RoHS Compliant, Pb-Free

### Applications

- LTE Band 3 / Band 7 Uplink Diplexer Infrastructure
- Base Station Infrastructure
- Small Cells
- Repeaters
- Routers
- LTE Dongles
- General Purpose Wireless

### Ordering Information

Part No.	Description
QPQ1237SB	5 filter modules (loose)
QPQ1237SR	100 pieces on a 7" reel
QPQ1237TR7	2,500 pieces on a 7" reel (standard)
QPQ1237EVB	Evaluation Board

## Absolute Maximum Ratings

Parameter	Rating
Storage Temperature	-40 to +125°C
Operation Temperature	-40 to +85 °C

## Life Test

Conditions	Rating
TBD	> TBD hours
TBD	> TBD hours

Electrical specifications are measured at specified test conditions.

## Electrical Specifications – B3 Uplink <sup>(1)</sup>

Test conditions unless otherwise specified. Temperature Range: -40 to +85 °C

Parameter	Conditions (1, 2)	Min	Typ	Max	Unit
Insertion Loss <sup>(2)</sup>	1710 – 1785 MHz	-	2.4	3.6	dB
Amplitude Variation <sup>(3)</sup>	1710 – 1785 MHz	-	-	2.2	dB
Input / Output Return Loss	1710 – 1785 MHz	8	-	-	dB
Group Delay Variation	1710 – 1785 MHz (+25 °C)	-	-	40	nS
	1710 – 1785 MHz	-	-	55	nS
	1710 – 1785 MHz (5MHz sliding window)	-	-	30	nS
Attenuation <sup>(4)</sup>	50 – 720 MHz	27	-	-	dB
	720 – 1670 MHz	27	-	-	dB
	1670 – 1690 MHz	17	-	-	dB
	1805 – 1825 MHz	32	-	-	dB
	1825 – 1880 MHz	44	-	-	dB
	1880 – 1920 MHz	30	-	-	dB
	1920 – 2110 MHz	40	-	-	dB
	2110 – 2170 MHz	33	-	-	dB
	2170 – 2500 MHz	24	-	-	dB
	2500 – 2690 MHz	26	-	-	dB
2690 – 3800 MHz	9	-	-	dB	
3800 – 5000 MHz	20	-	-	dB	

Notes:

1. All specifications are based on the QORVO schematic for the main reference design.
2. Maximum Insertion Loss within defined frequency range.
3. Amplitude Variation is defined as the difference between the lowest loss and the highest loss within 10 MHz channels.
4. Attenuation is referenced to zero dB

## Electrical Specifications – B7 Uplink <sup>(1)</sup>

Test conditions unless otherwise specified. Temperature Range: -40 to +85 °C

Parameter	Conditions (1, 2)	Min	Typ	Max	Unit
Insertion Loss <sup>(2)</sup>	2500 – 2570 MHz	-	2.3	3.8	dB
Amplitude Variation <sup>(3)</sup>	2500 – 2570 MHz	-	1.5	2.3	dB
Input / Output Return Loss	2500 – 2570 MHz	8	-	-	dB
Group Delay Variation	2500 – 2570 MHz (+25 °C)	-	-	20	nS
	2500 – 2570 MHz	-	-	40	nS
	2500 – 2570 MHz (5MHz sliding window)	-	-	30	
Attenuation <sup>(4)</sup>	10 – 1100 MHz	35	-	-	dB
	1100 – 1710 MHz	30	-	-	dB
	1710 – 1880 MHz	36	-	-	dB
	1880 – 2170 MHz	30	-	-	dB
	2170 – 2260 MHz	32	-	-	dB
	2260 – 2450 MHz	31	-	-	dB
	2450 – 2480 MHz	12	-	-	dB
	2590 – 2620 MHz	10	-	-	dB
	2620 – 2690 MHz	39	-	-	dB
	2690 – 2900 MHz	32	-	-	dB
2900 – 3800 MHz	25	-	-	dB	
3800 – 5000 MHz	13	-	-	dB	

Notes:

1. All specifications are based on the QORVO schematic for the main reference design.
2. Maximum Insertion Loss within defined frequency range.
3. Amplitude Variation is defined as the difference between the lowest loss and the highest loss within 10 MHz channels.
4. Attenuation is referenced to zero dB

## Electrical Specifications – Isolation <sup>(1)</sup>

Test conditions unless otherwise specified. Temperature Range: -40 to +85 °C

Parameter	Conditions (1, 2)	Min	Typ	Max	Unit
Isolation	1710 – 1785 MHz	39	-	-	dB
	2500 – 2570 MHz	33	-	-	dB

Notes:

1. All specifications are based on the QORVO schematic for the main reference design.

**QPQ1237EVB Evaluation Board**

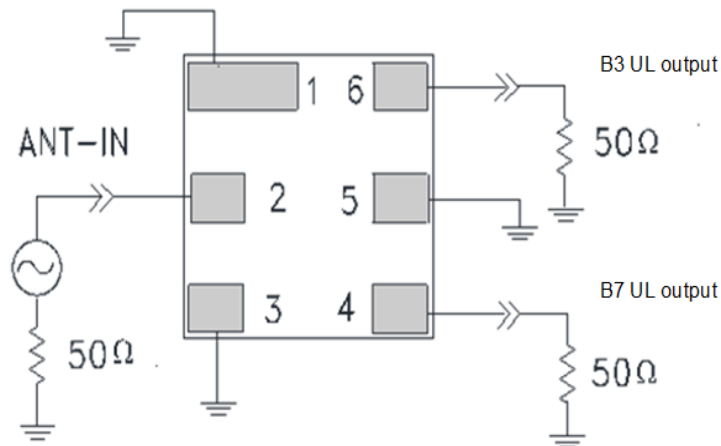
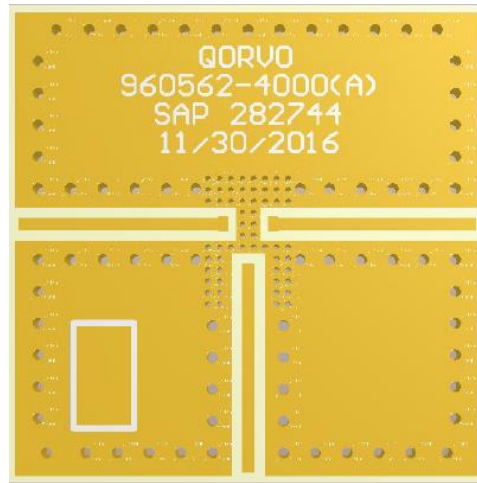

**Bill of Material – QPQ1237EVB**

Reference Des.	Value	Description	Manuf.	Part Number
U1	n/a	QPQ1237	Qorvo	QPQ1237
SMA	n/a	SMA connector	Amphenol	901-100-44-6RFX
PCB	n/a	3-Layer	Multiple	960562

**Performance Plots Band 3 Uplink**

Test conditions unless otherwise noted: Temp= +25°C

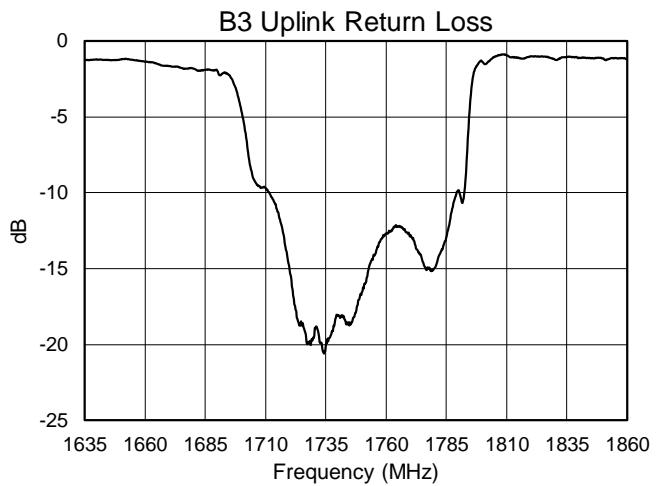
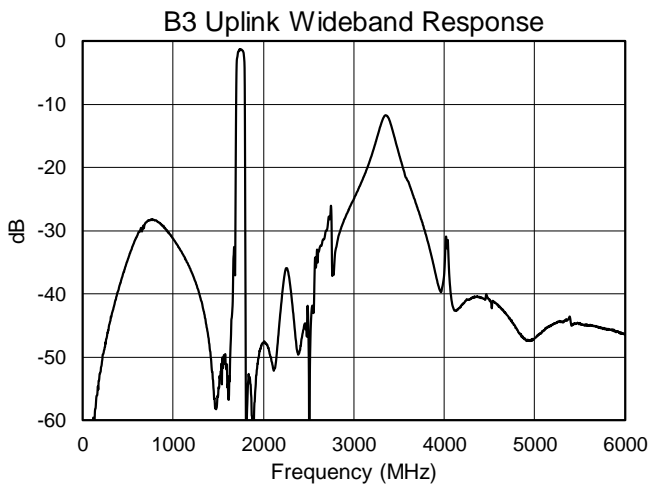
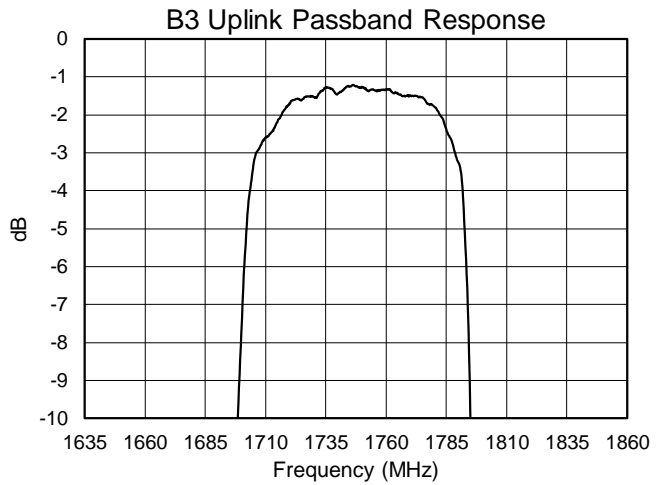
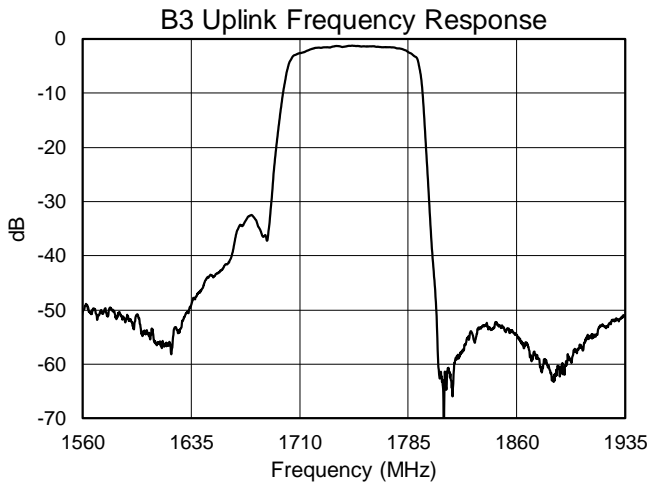

**Ant Port Impedance**

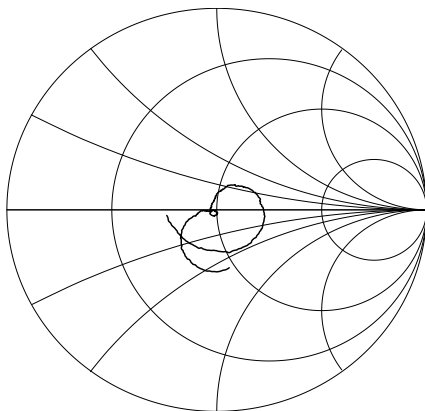

**B3 Uplink Port Impedance**

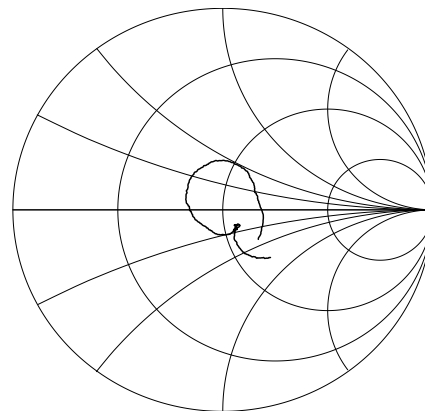

**Performance Plots Band 7 Uplink**

Test conditions unless otherwise noted: Temp= +25°C

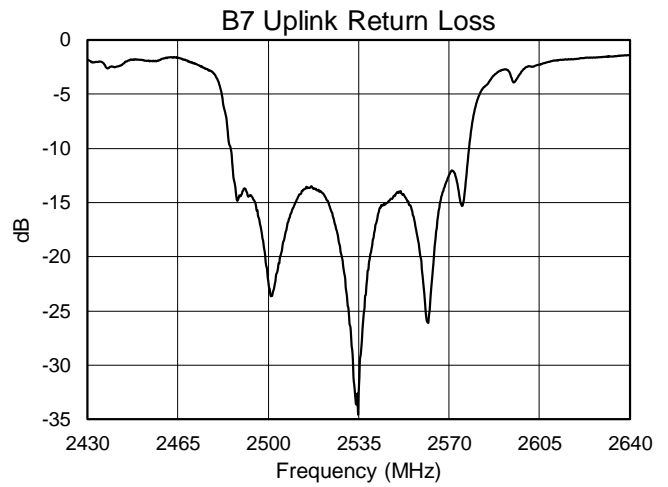
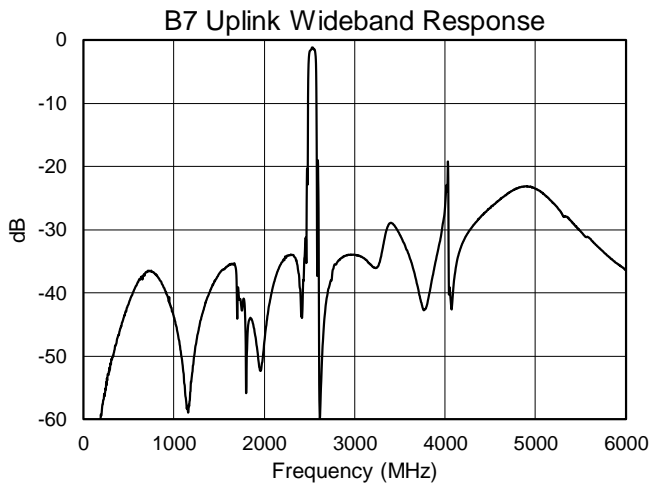
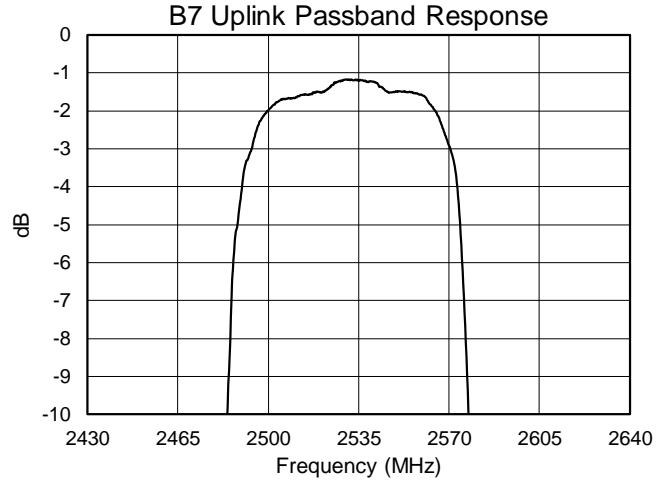
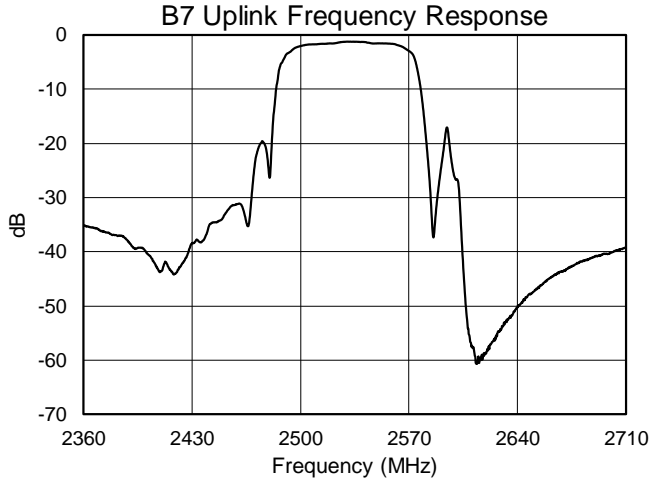

**Ant Port Impedance**

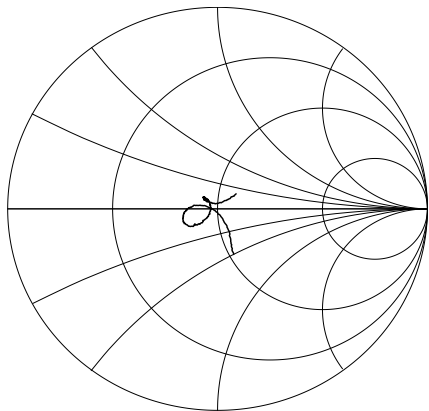

**B7 Uplink Port Impedance**

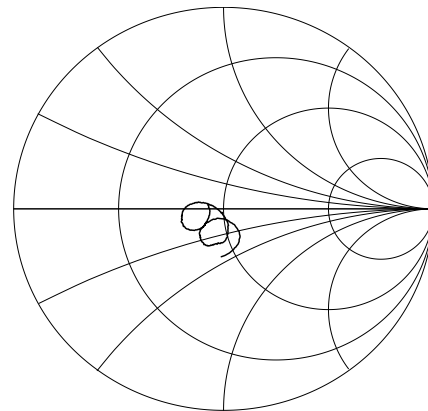

Performance Plots Isolation

Test conditions unless otherwise noted: Temp= +25°C

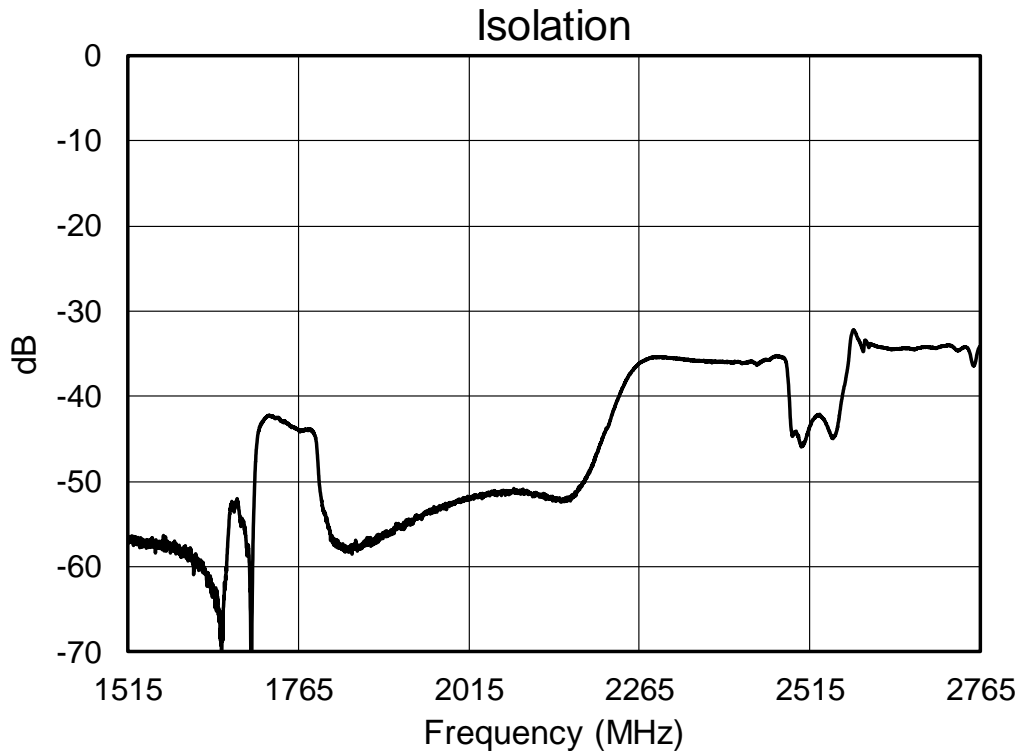
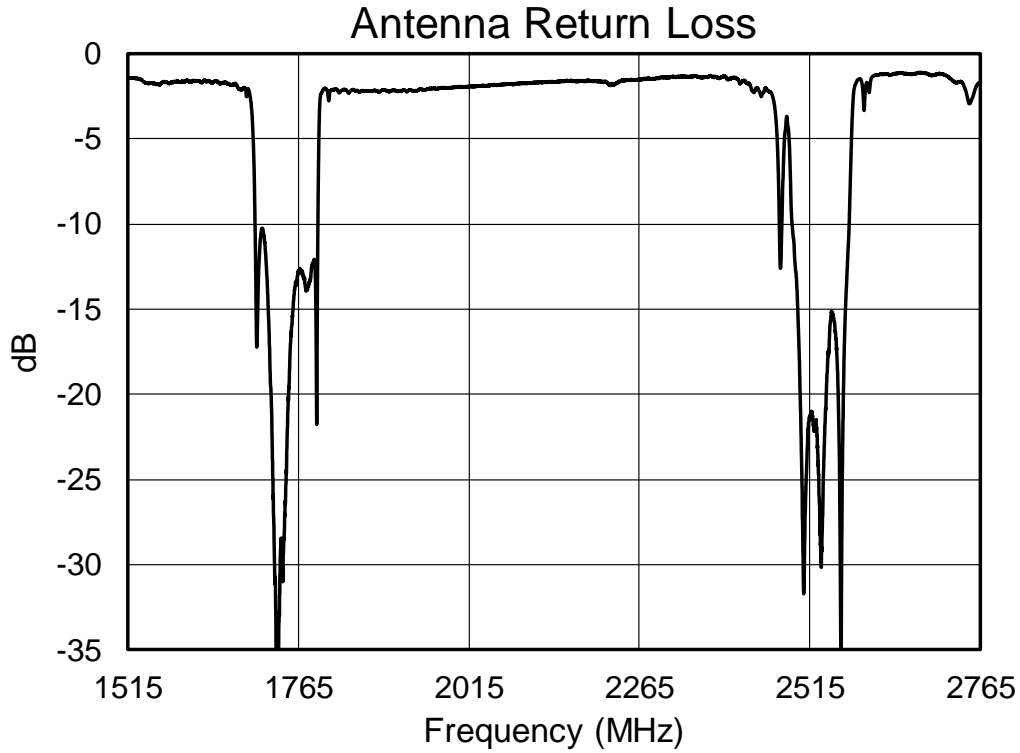

**Package Dimensions**

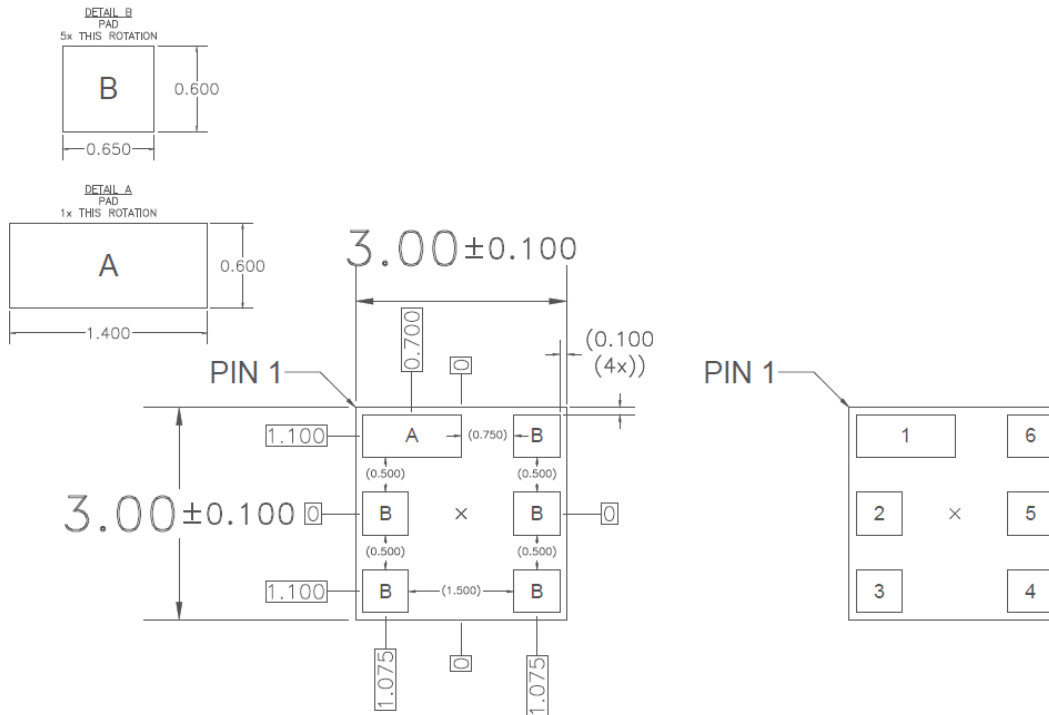
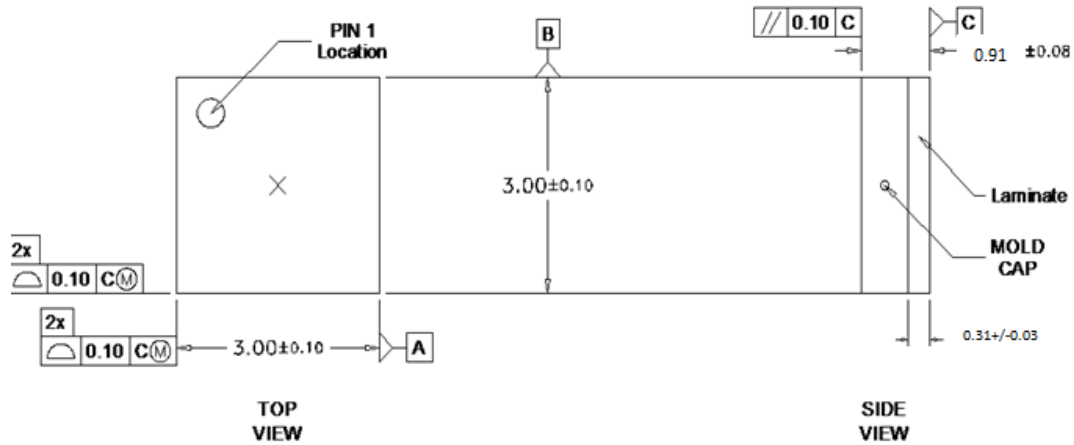

**Notes:**

1. All dimensions are in millimeters. Angles are in degrees.
2. Dimension and tolerance formats conform to ASME Y14.4M-1994.
3. The terminal #1 identifier and terminal numbering conform to JESD 95-1 SPP-012.

**Package Marking**

**Package Marking**

Qorvo Logo  
 Product Identifier: 1237  
 Trace Code: XXXX

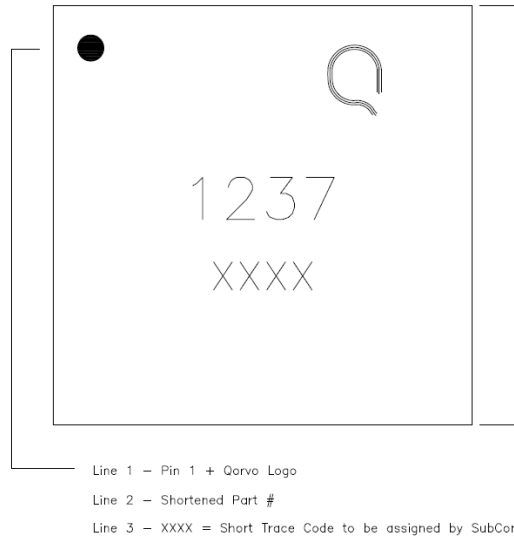

**PCB Mounting Pattern**

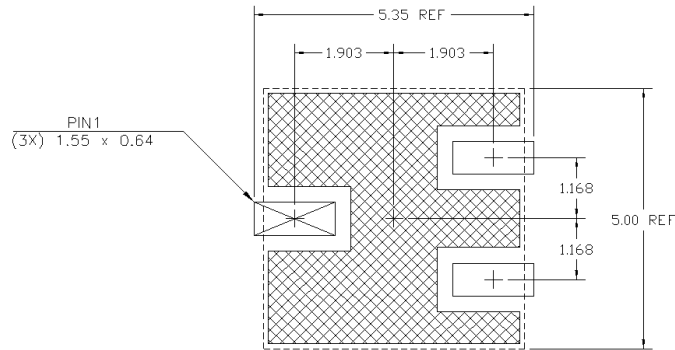

**Notes:**

1. All dimensions are in millimeters. Angles are in degrees.
2. This drawing specifies the mounting pattern used on the Qorvo evaluation board for this product. Some modification may be necessary to suit end user assembly materials and processes.

**Tape and Reel Information – Carrier and Cover Tape Dimensions**

Tape and reel specifications for this part are also available on the Qorvo website.  
 Standard T/R size = 2500 pieces on a 7” reel.

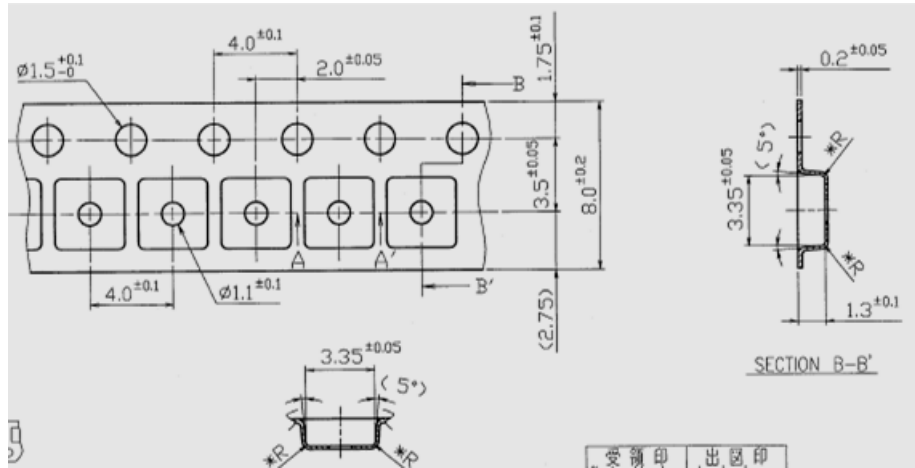

Feature	Measure	Symbol	Size (in)	Size (mm)
Cavity	Length	A0	0.132	3.35
	Width	B0	0.132	3.35
	Depth	K0	0.051	1.30
	Pitch	P1	0.157	4.00
Centerline Distance	Cavity to Perforation - Length Direction	P2	0.079	2.00
	Cavity to Perforation - Width Direction	F	0.138	3.50
Cover Tape	Width	C	0.213	5.40
Carrier Tape	Width	W	0.315	8.00

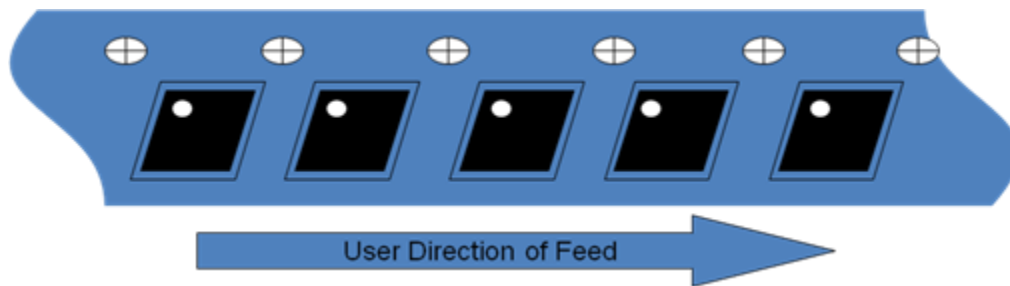

**Tape and Reel Information – Reel Dimensions**

Tape and reel specifications for this part are also available on the Qorvo website.  
 Standard T/R size = 2,500 pieces on a 7" reel.

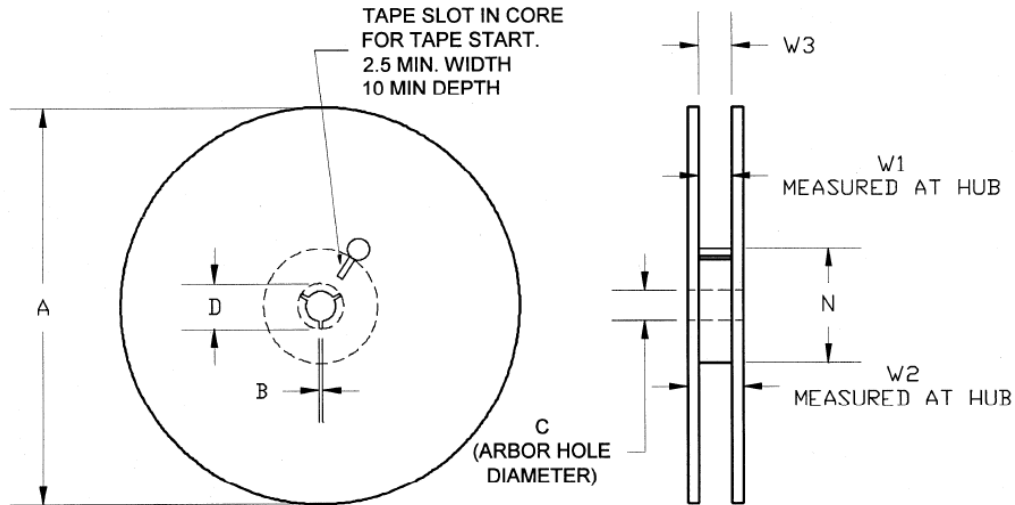

Feature	Measure	Symbol	Size (in)	Size (mm)
Flange	Diameter	A	6.969	177.0
	Thickness	W2	0.559	14.2
	Space Between Flange	W1	0.346	8.8
Hub	Outer Diameter	N	2.283	58.0
	Arbor Hole Diameter	C	0.512	13.0
	Key Slit Width	B	0.079	2.0
	Key Slit Diameter	D	0.787	20.0

## Handling Precautions

Parameter	Rating	Standard
ESD – Human Body Model (HBM)	Class TBD	ESDA / JEDEC JS-001-2012
ESD – Charged Device Model (CDM)	Class TBD	ESDA / JEDEC JS-002-2014
MSL – Moisture Sensitivity Level	Level 3	IPC/JEDEC J-STD-020



Caution!  
ESD-Sensitive Device

## Solderability

Compatible with both lead-free (260°C max. reflow temp.) and tin/lead (245°C max. reflow temp.) soldering processes. Solder profiles available upon request.

Contact plating: TBD

## RoHS Compliance

This part is compliant with 2011/65/EU RoHS directive (Restrictions on the Use of Certain Hazardous Substances in Electrical and Electronic Equipment) as amended by Directive 2015/863/EU.

This product also has the following attributes:

- Lead Free
- Halogen Free (Chlorine, Bromine)
- Antimony Free
- TBBP-A (C<sub>15</sub>H<sub>12</sub>Br<sub>4</sub>O<sub>2</sub>) Free
- PFOS Free
- SVHC Free



## Contact Information

For the latest specifications, additional product information, worldwide sales and distribution locations:

**Web:** [www.qorvo.com](http://www.qorvo.com)

**Tel:** 1-844-890-8163

**Email:** [customer.support@qorvo.com](mailto:customer.support@qorvo.com)

For technical questions and application information: **Email:** [appsupport@qorvo.com](mailto:appsupport@qorvo.com)

## Important Notice

The information contained herein is believed to be reliable; however, Qorvo makes no warranties regarding the information contained herein and assumes no responsibility or liability whatsoever for the use of the information contained herein. All information contained herein is subject to change without notice. Customers should obtain and verify the latest relevant information before placing orders for Qorvo products. The information contained herein or any use of such information does not grant, explicitly or implicitly, to any party any patent rights, licenses, or any other intellectual property rights, whether with regard to such information itself or anything described by such information. **THIS INFORMATION DOES NOT CONSTITUTE A WARRANTY WITH RESPECT TO THE PRODUCTS DESCRIBED HEREIN, AND QORVO HEREBY DISCLAIMS ANY AND ALL WARRANTIES WITH RESPECT TO SUCH PRODUCTS WHETHER EXPRESS OR IMPLIED BY LAW, COURSE OF DEALING, COURSE OF PERFORMANCE, USAGE OF TRADE OR OTHERWISE, INCLUDING THE IMPLIED WARRANTIES OF MERCHANTABILITY AND FITNESS FOR A PARTICULAR PURPOSE.**

Without limiting the generality of the foregoing, Qorvo products are not warranted or authorized for use as critical components in medical, life-saving, or life-sustaining applications, or other applications where a failure would reasonably be expected to cause severe personal injury or death.

Copyright 2017 © Qorvo, Inc. | Qorvo is a registered trademark of Qorvo, Inc.