

High Temperature, 2.5 A Output Current, Gate Drive Optocoupler

FOD3125

Description

The FOD3125 is a 2.5 A Output Current Gate Drive Optocoupler, capable of driving most medium IGBTs or MOSFETs across extended industrial temperature range, $-40\text{ }^{\circ}\text{C}$ to $125\text{ }^{\circ}\text{C}$. It is ideally suited for fast switching driving of power IGBTs and MOSFETs used in motor control inverter applications, and high performance power system.

It utilizes onsemi patented coplanar packaging technology, OPTOPLANAR[®], and optimized IC design to achieve high noise immunity, characterized by high common mode rejection.

It consists of a gallium aluminum arsenide (AlGaAs) light emitting diode optically coupled to an integrated circuit with a high-speed driver for push-pull MOSFET output stage.

Features

- Extended Industrial Temperature Range, $-40\text{ }^{\circ}\text{C}$ to $125\text{ }^{\circ}\text{C}$
- High Noise Immunity characterized by 35 kV/ μs minimum Common Mode Rejection
- 2.5 A Peak Output Current Driving Capability for Most 1200 V/20 A IGBT
- Use of P-channel MOSFETs at Output Stage Enables Output Voltage Swing close to the Supply Rail
- Wide Supply Voltage Range from 15 V to 30 V
- Fast Switching Speed
 - ◆ 400 ns maximum Propagation Delay
 - ◆ 100 ns maximum Pulse Width Distortion
- Under Voltage LockOut (UVLO) with Hysteresis
- Safety and Regulatory Approvals
 - ◆ UL1577, 5000 V_{RMS} for 1 minute
 - ◆ DIN EN/IEC60747-5-5 (pending approval)
- >8.0 mm Clearance and Creepage Distance (Option ‘T’ or ‘TS’)
- 1,414 V Peak Working Insulation Voltage (VIORM)
- This is a Pb-Free Device

Applications

- Industrial Inverter
- Uninterruptible Power Supply
- Induction Heating
- Isolated IGBT/Power MOSFET Gate Drive

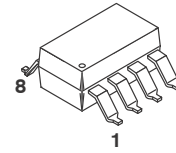

PDIP8 GW
CASE 709AD

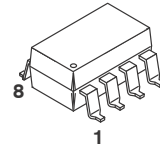

PDIP8 GW
CASE 709AC

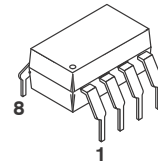

PDIP8 6.6x3.81, 2.54P
CASE 646BW

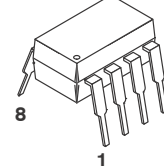

PDIP8 9.655x6.6, 2.54P
CASE 646CQ

FUNCTIONAL BLOCK DIAGRAM

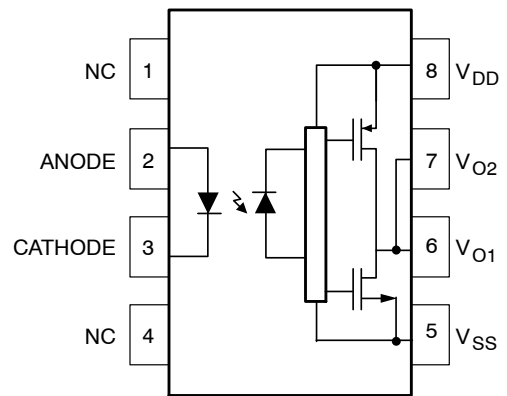

Note: A 0.1 μF bypass capacitor must be connected between pins 5 and 8.

ORDERING INFORMATION

See detailed ordering and shipping information on page 15 of this data sheet.

FOD3125

Table 1. TRUTH TABLE

| LED | V _{DD} – V _{SS} “Positive Going” (Turn-on) | V _{DD} – V _{SS} “Negative Going” (Turn-off) | V _O |
|-----|--|---|----------------|
| Off | 0 V to 30 V | 0 V to 30 V | Low |
| On | 0 V to 11 V | 0 V to 9.7 V | Low |
| On | 11 V to 14 V | 9.7 V to 12.7 V | Transition |
| On | 14 V to 30 V | 12.7 V to 30 V | High |

Table 2. PIN DEFINITIONS

| Pin # | Name | Description |
|-------|---------|---|
| 1 | NC | Not Connected |
| 2 | Anode | LED Anode |
| 3 | Cathode | LED Cathode |
| 4 | NC | Not Connected |
| 5 | VSS | Negative Supply Voltage |
| 6 | VO2 | Output Voltage 2 (internally connected to V _{O1}) |
| 7 | VO1 | Output Voltage 1 |
| 8 | VDD | Positive Supply Voltage |

Table 3. SAFETY AND INSULATION RATINGS

As per DIN EN/IEC 60747-5-5 (pending approval). This optocoupler is suitable for “safe electrical insulation” only within the safety limit data. Compliance with the safety ratings shall be ensured by means of protective circuits.

| Symbol | Parameter | Min | Typ | Max | Unit |
|----------------------|--|--------|-----------|-----|-------------------|
| | Installation Classifications per DIN VDE 0110/1.89 Table 1 | | I–IV | | |
| | For Rated Main Voltage < 150 Vrms | | I–IV | | |
| | For Rated Main Voltage < 300 Vrms | | I–III | | |
| | For Rated Main Voltage < 450 Vrms | | I–III | | |
| | For Rated Main Voltage < 600 Vrms | | I–III | | |
| | For Rated Main Voltage < 1000 Vrms (option T, TS) | | I–III | | |
| | Climatic Classification | | 40/125/21 | | |
| | Pollution Degree (DIN VDE 0110/1.89) | | 2 | | |
| CTI | Comparative Tracking Index | 175 | | | |
| V _{PR} | Input to Output Test Voltage, Method b, V _{IORM} × 1.875 = V _{PR} , 100% Production Test with t _m = 1 second, Partial Discharge < 5 pC | 2651 | | | |
| | Input to Output Test Voltage, Method a, V _{IORM} × 1.6 = V _{PR} , Type and Sample Test with t _m = 10 second, Partial Discharge < 5 pC | 2262 | | | |
| V _{IORM} | Max Working Insulation Voltage | 1414 | | | V _{peak} |
| V _{IOTM} | Highest Allowable Over Voltage | 6000 | | | V _{peak} |
| | External Creepage | ≥8 | | | mm |
| | External Clearance | ≥7.4 | | | mm |
| | External Clearance (for Option T or TS, 0.4” Lead Spacing) | ≥10.16 | | | mm |
| | Insulation Thickness | ≥0.5 | | | mm |
| T _{Case} | Case Temperature – Maximum Values Allowed in the Event of a Failure | 175 | | | °C |
| I _{S,INPUT} | Input Current – Maximum Values Allowed in the Event of a Failure | 400 | | | mA |

FOD3125

Table 3. SAFETY AND INSULATION RATINGS (continued)

As per DIN EN/IEC 60747-5-5 (pending approval). This optocoupler is suitable for “safe electrical insulation” only within the safety limit data. Compliance with the safety ratings shall be ensured by means of protective circuits.

| Symbol | Parameter | Min | Typ | Max | Unit |
|----------------|---|---------|-----|-----|----------|
| $P_{S,OUTPUT}$ | Output Power (Duty Factor $\leq 2.7\%$) – Maximum Values Allowed in the Event of a Failure | 700 | | | mW |
| R_{IO} | Insulation Resistance at T_S , $V_{IO} = 500\text{ V}$ – Maximum Values Allowed in the Event of a Failure | $>10^9$ | | | Ω |

Table 4. ABSOLUTE MAXIMUM RATINGS ($T_A = 25\text{ }^\circ\text{C}$ unless otherwise specified.)

| Symbol | Parameter | Value | Unit |
|------------------------|--|-------------------------------------|------------------|
| T_{STG} | Storage Temperature | -40 to +125 | $^\circ\text{C}$ |
| T_{OPR} | Operating Temperature | -40 to +125 | $^\circ\text{C}$ |
| T_J | Junction Temperature | -40 to +125 | $^\circ\text{C}$ |
| T_{SOL} | Lead Wave Solder Temperature (refer to page 12 for reflow solder profile) | 260 for 10 sec | $^\circ\text{C}$ |
| $I_{F(AVG)}$ | Average Input Current | 25 | mA |
| f | Operating Frequency (Note 1) | 50 | kHz |
| V_R | Reverse Input Voltage | 5 | V |
| $I_{O(PEAK)}$ | Peak Output Current (Note 2) | 3 | A |
| $V_{DD} - V_{SS}$ | Supply Voltage | | 0 to 35 |
| | | $T_A \geq 90\text{ }^\circ\text{C}$ | 0 to 30 |
| $V_{O(PEAK)}$ | Peak Output Voltage | 0 to V_{DD} | V |
| $t_{R(IN)}, t_{F(IN)}$ | Input Signal Rise and Fall Time | 500 | ns |
| PD_I | Input Power Dissipation (Notes 3, 5) | 45 | mW |
| PD_O | Output Power Dissipation (Notes 4, 5) | 250 | mW |

Stresses exceeding those listed in the Maximum Ratings table may damage the device. If any of these limits are exceeded, device functionality should not be assumed, damage may occur and reliability may be affected.

1. Exponential Waveform, $I_{O(PEAK)} \leq |2.5\text{ A}| \leq 0.3\text{ }\mu\text{s}$
2. Maximum pulse width = 10 μs , maximum duty cycle = 1.1 %.
3. Derate linearly above 87 $^\circ\text{C}$, free air temperature at a rate of 0.77 mW/ $^\circ\text{C}$.
4. Derate linearly above 100 $^\circ\text{C}$, free air temperature at a rate of 5.7 mW/ $^\circ\text{C}$.
5. Functional operation under these conditions is not implied. Permanent damage may occur if the device is subjected to conditions outside these ratings.

Table 5. RECOMMENDED OPERATING CONDITIONS

| Symbol | Parameter | Value | Unit |
|-------------------|-------------------------------|-------------|------------------|
| T_A | Ambient Operating Temperature | -40 to +125 | $^\circ\text{C}$ |
| $V_{DD} - V_{SS}$ | Power Supply | 15 to 30 | V |
| $I_{F(ON)}$ | Input Current (ON) | 7 to 16 | mA |
| $V_{F(OFF)}$ | Input Voltage (OFF) | 0 to 0.8 | V |

Functional operation above the stresses listed in the Recommended Operating Ranges is not implied. Extended exposure to stresses beyond the Recommended Operating Ranges limits may affect device reliability.

FOD3125

Table 6. ISOLATION CHARACTERISTICS

Apply over all recommended conditions, typical value is measured at $T_A = 25\text{ }^\circ\text{C}$

| Symbol | Parameter | Conditions | Min | Typ | Max | Unit |
|-----------|--------------------------------|---|------|-----------|-----|-----------|
| V_{ISO} | Input-Output Isolation Voltage | $T_A = 25\text{ }^\circ\text{C}$, R.H. < 50 %, $t = 1.0$ minute, $I_{I-O} \leq 10\text{ }\mu\text{A}$, 50 Hz (Notes 6, 7) | 5000 | | | V_{RMS} |
| R_{ISO} | Isolation Resistance | $V_{I-O} = 500\text{ V}$ (Note 6) | | 10^{11} | | Ω |
| C_{ISO} | Isolation Capacitance | $V_{I-O} = 0\text{ V}$, Frequency = 1.0 MHz (Note 6) | | 1 | | pF |

6. Device is considered a two terminal device: pins 2 and 3 are shorted together and pins 5, 6, 7 and 8 are shorted together.

7. 5,000 V_{RMS} for 1 minute duration is equivalent to 6,000 VAC_{RMS} for 1 second duration.

Table 7. ELECTRICAL CHARACTERISTICS

| Symbol | Parameter | Conditions | Min | Typ | Max | Unit |
|---------------------|--|--|--------------------------|-------------------------|--------------------------|----------------------|
| V_F | Input Forward Voltage | $I_F = 10\text{ mA}$ | 1.1 | 1.5 | 1.8 | V |
| $\Delta(V_F / T_A)$ | Temperature Coefficient of Forward Voltage | | | -1.8 | | mV/ $^\circ\text{C}$ |
| BV_R | Input Reverse Breakdown Voltage | $I_R = 10\text{ }\mu\text{A}$ | 5 | | | V |
| C_{IN} | Input Capacitance | $f = 1\text{ MHz}$, $V_F = 0\text{ V}$ | | 20 | | pF |
| I_{OH} | High Level Output Current (Note 1) | $V_O = V_{DD} - 3\text{ V}$ | -1.0 | -2.0 | | A |
| | | $V_O = V_{DD} - 6\text{ V}$ | -2.0 | | | |
| I_{OL} | Low Level Output Current (Note 1) | $V_O = V_{SS} + 3\text{ V}$ | 1.0 | 2.0 | | A |
| | | $V_O = V_{SS} + 6\text{ V}$ | 2.0 | | | |
| V_{OH} | High Level Output Voltage | $I_F = 10\text{ mA}$, $I_O = -2.5\text{ A}$ | $V_{DD} - 6.25\text{ V}$ | $V_{DD} - 2.5\text{ V}$ | | V |
| | | $I_F = 10\text{ mA}$, $I_O = -100\text{ mA}$ | $V_{DD} - 0.25\text{ V}$ | $V_{DD} - 0.1\text{ V}$ | | |
| V_{OL} | Low Level Output Voltage | $I_F = 0\text{ mA}$, $I_O = 2.5\text{ A}$ | | $V_{SS} + 2.5\text{ V}$ | $V_{SS} + 6.25\text{ V}$ | V |
| | | $I_F = 0\text{ mA}$, $I_O = 100\text{ mA}$ | | $V_{SS} + 0.1\text{ V}$ | $V_{SS} + 0.25\text{ V}$ | |
| I_{DDH} | High Level Supply Current | $V_O = \text{Open}$, $I_F = 7\text{ to }16\text{ mA}$ | | 2.8 | 3.8 | mA |
| I_{DDL} | Low Level Supply Current | $V_O = \text{Open}$, $V_F = 0\text{ to }0.8\text{ V}$ | | 2.8 | 3.8 | mA |
| I_{FLH} | Threshold Input Current Low to High | $I_O = 0\text{ mA}$, $V_O > 5\text{ V}$ | | 2.3 | 5.0 | mA |
| V_{FHL} | Threshold Input Voltage High to Low | $I_O = 0\text{ mA}$, $V_O < 5\text{ V}$ | 0.8 | | | V |
| V_{UVLO+} | Under Voltage Lockout Threshold | $I_F = 10\text{ mA}$, $V_O > 5\text{ V}$ | 11 | 12.7 | 14 | V |
| V_{UVLO-} | | $I_F = 10\text{ mA}$, $V_O < 5\text{ V}$ | 9.7 | 11.2 | 12.7 | V |
| $UVLO_{HYS}$ | Under Voltage Lockout Threshold Hysteresis | | | 1.5 | | V |

Product parametric performance is indicated in the Electrical Characteristics for the listed test conditions, unless otherwise noted. Product performance may not be indicated by the Electrical Characteristics if operated under different conditions.

8. Maximum pulse width = 10 μs , maximum duty cycle = 1.1 %.

FOD3125

Table 8. SWITCHING CHARACTERISTICS

Apply over all recommended conditions, typical value is measured at $V_{DD} = 30\text{ V}$, $V_{SS} = \text{Ground}$, $T_A = 25\text{ }^\circ\text{C}$ unless otherwise specified.

| Symbol | Parameter | Conditions | Min | Typ | Max | Unit |
|-----------------|--|---|---|------|-----|-------------------------|
| t_{PHL} | Propagation Delay Time to Logic Low Output | $I_F = 7\text{ mA to }16\text{ mA}$, $R_g = 10\ \Omega$, $C_g = 10\text{ nF}$, $f = 10\text{ kHz}$, Duty Cycle = 50 % | 150 | 275 | 400 | ns |
| t_{PLH} | Propagation Delay Time to Logic High Output | | 150 | 255 | 400 | ns |
| PWD | Pulse Width Distortion, $ t_{PHL} - t_{PLH} $ | | | 20 | 100 | ns |
| PDD (Skew) | Propagation Delay Difference Between Any Two Parts or Channels, $(t_{PHL} - t_{PLH})$ (Note 9) | | | -250 | 250 | ns |
| t_r | Output Rise Time (10% – 90%) | | | | 60 | ns |
| t_f | Output Fall Time (90% – 10%) | | | | 60 | ns |
| $t_{UVLO\ ON}$ | UVLO Turn On Delay | | $I_F = 10\text{ mA}$, $V_O > 5\text{ V}$ | | 1.6 | |
| $t_{UVLO\ OFF}$ | UVLO Turn Off Delay | $I_F = 10\text{ mA}$, $V_O < 5\text{ V}$ | | 0.4 | | μs |
| $ CM_H $ | Common Mode Transient Immunity at Output High | $T_A = 25\text{ }^\circ\text{C}$, $V_{DD} = 30\text{ V}$, $I_F = 7\text{ to }16\text{ mA}$, $V_{CM} = 2000\text{ V}$ (Note 10) | 35 | 50 | | $\text{kV}/\mu\text{s}$ |
| $ CM_L $ | Common Mode Transient Immunity at Output Low | $T_A = 25\text{ }^\circ\text{C}$, $V_{DD} = 30\text{ V}$, $V_F = 0\text{ V}$, $V_{CM} = 2000\text{ V}$ (Note 11) | 35 | 50 | | $\text{kV}/\mu\text{s}$ |

9. The difference between t_{PHL} and t_{PLH} between any two FOD3125 parts under same test conditions.

10. Common mode transient immunity at output high is the maximum tolerable negative dV_{cm}/dt on the trailing edge of the common mode impulse signal, V_{cm} , to assure that the output will remain high (i.e., $V_O > 15.0\text{ V}$).

11. Common mode transient immunity at output low is the maximum tolerable positive dV_{cm}/dt on the leading edge of the common pulse signal, V_{cm} , to assure that the output will remain low (i.e., $V_O < 1.0\text{ V}$).

TYPICAL PERFORMANCE CURVES

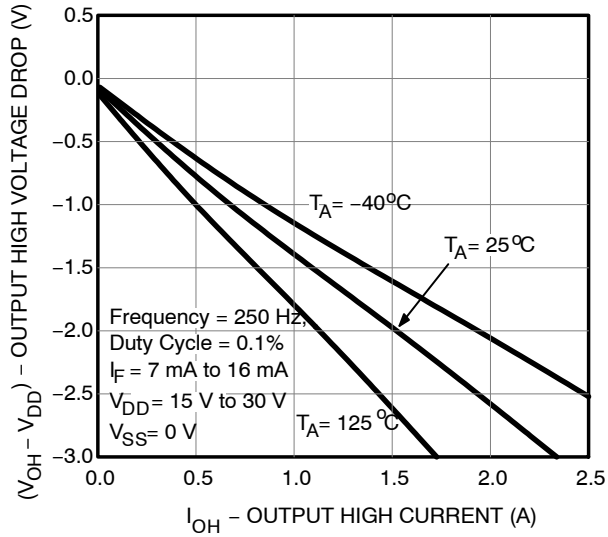

Figure 1. Output High Voltage Drop vs. Output High Current

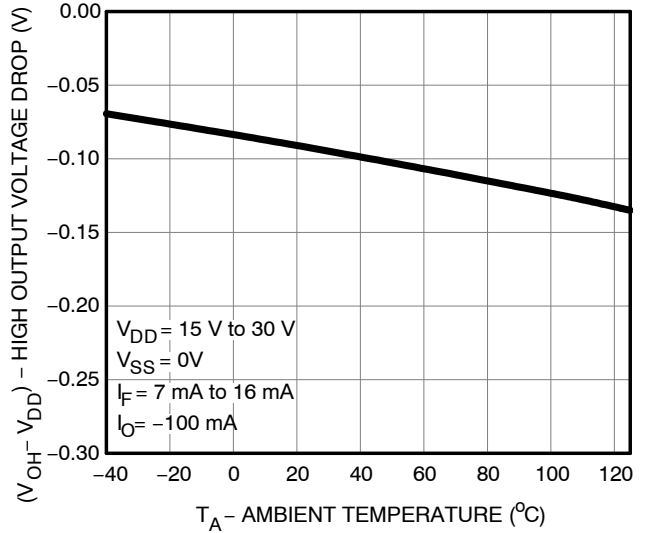

Figure 2. Output High Voltage Drop vs. Ambient Temperature

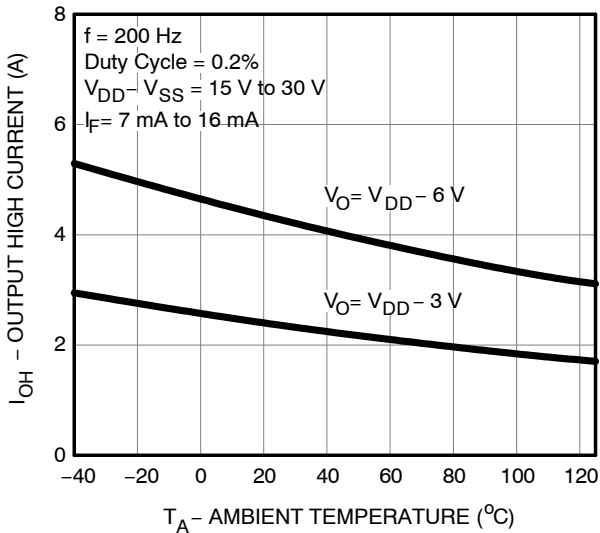

Figure 3. Output High Current vs. Ambient Temperature

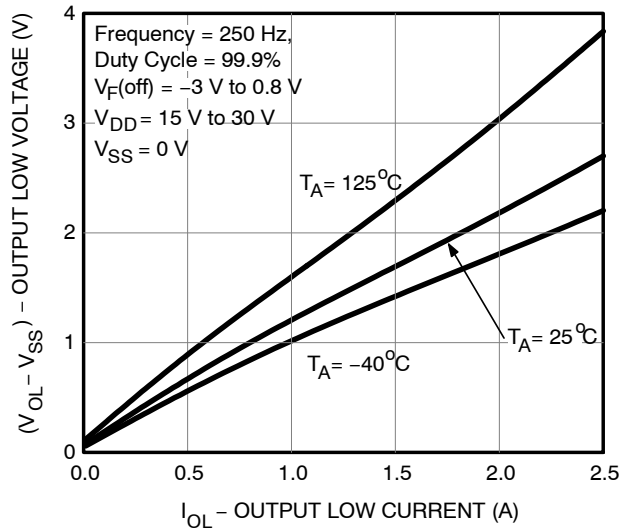

Figure 4. Output Low Voltage vs. Output Low Current

FOD3125

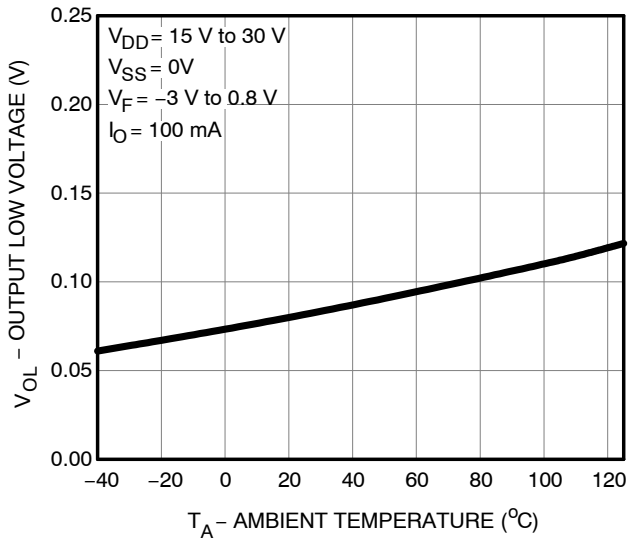

Figure 5. Output Low Voltage vs. Ambient Temperature

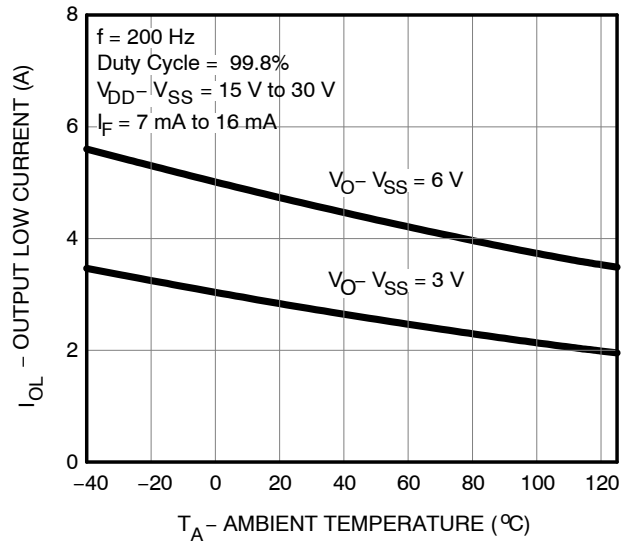

Figure 6. Output Low Current vs. Ambient Temperature

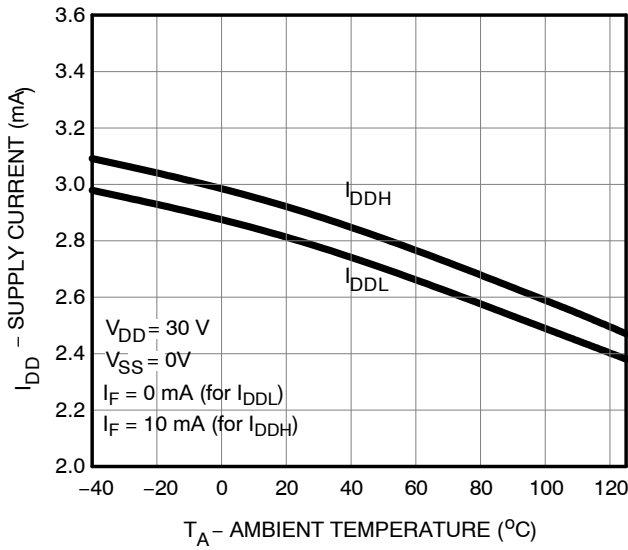

Figure 7. Supply Current vs. Ambient Temperature

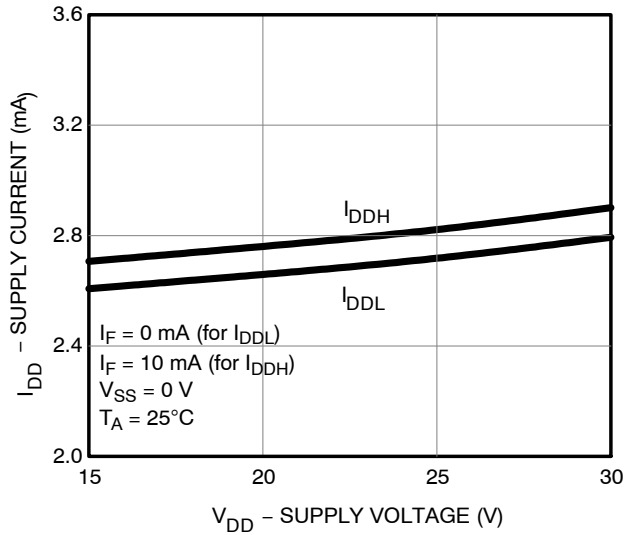

Figure 8. Supply Current vs. Supply Voltage

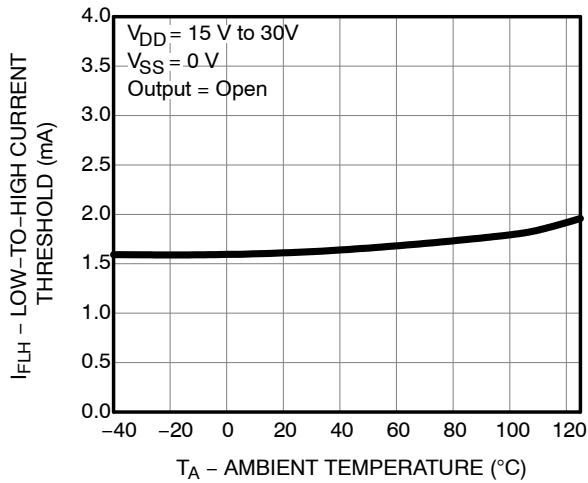

Figure 9. Low to High Input Current Threshold vs. Ambient Temperature

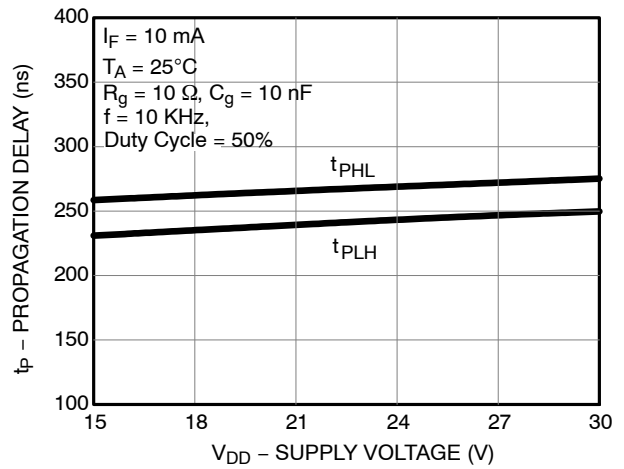

Figure 10. Propagation Delay vs. Supply Voltage

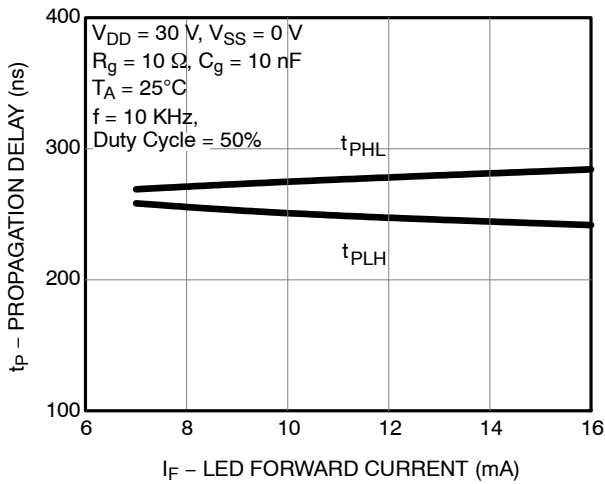

Figure 11. Propagation Delay vs. LED Forward Current

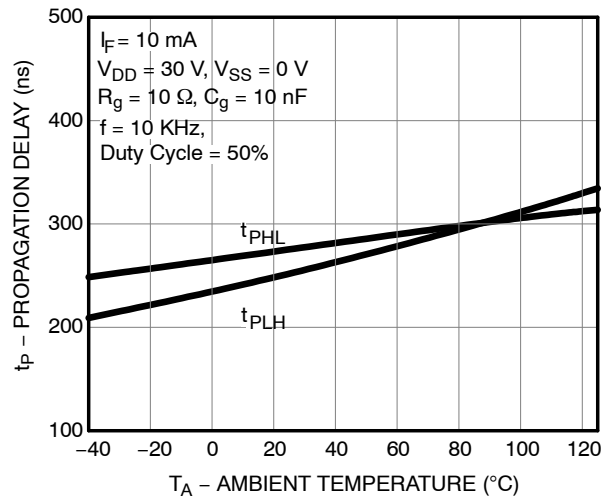

Figure 12. Propagation Delay vs. Ambient Temperature

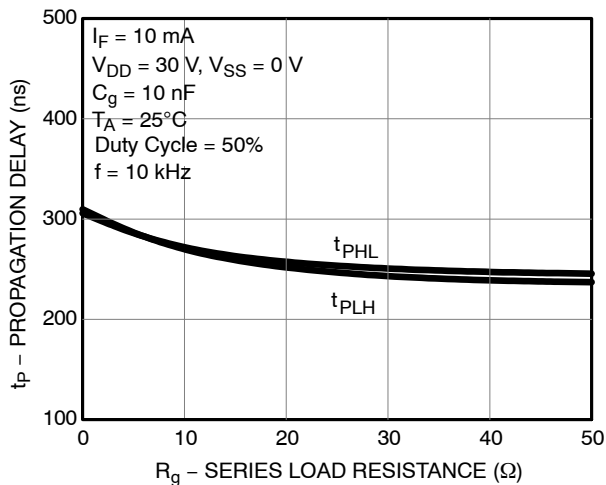

Figure 13. Propagation Delay vs. Series Load Resistance

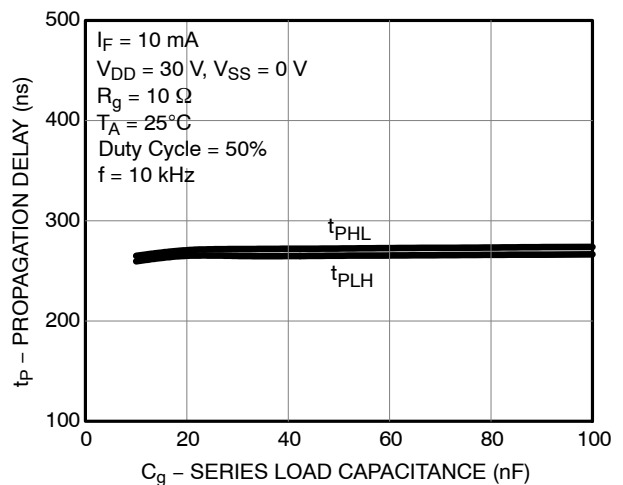

Figure 14. Propagation Delay vs. Load Capacitance

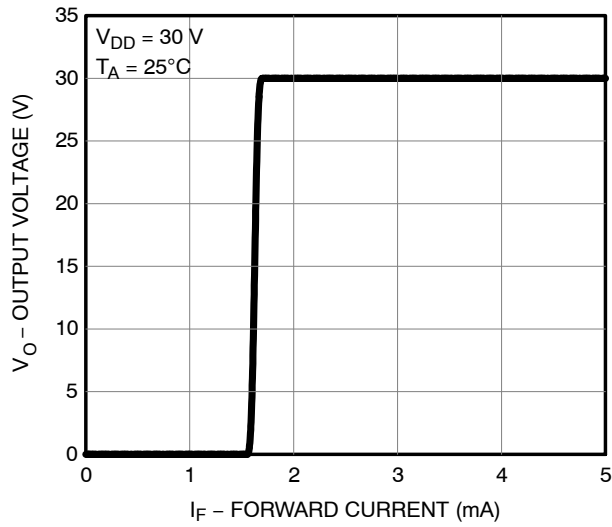

Figure 15. Transfer Characteristics

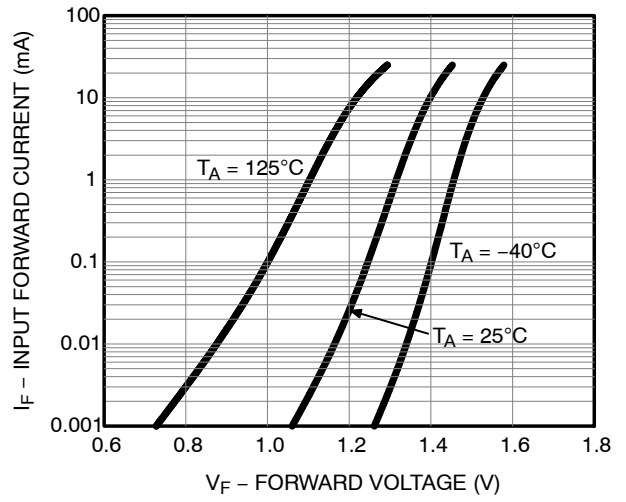

Figure 16. Input Forward Current vs. Forward Voltage

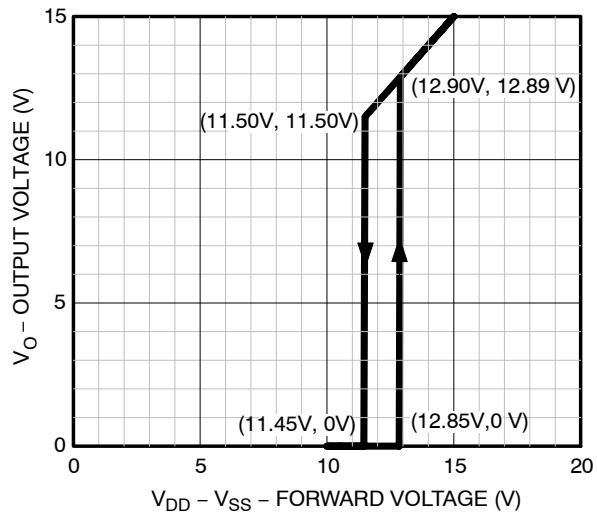

Figure 17. Under Voltage Lockout

FOD3125

TEST CIRCUIT

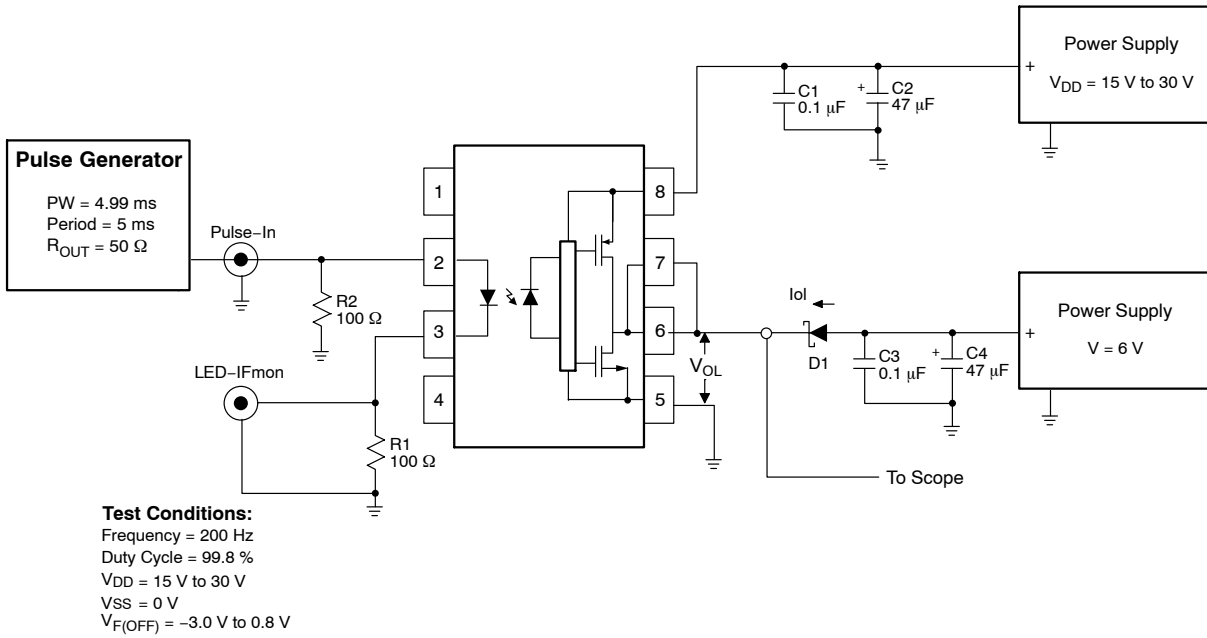

Figure 18. I_{OL} Test Circuit

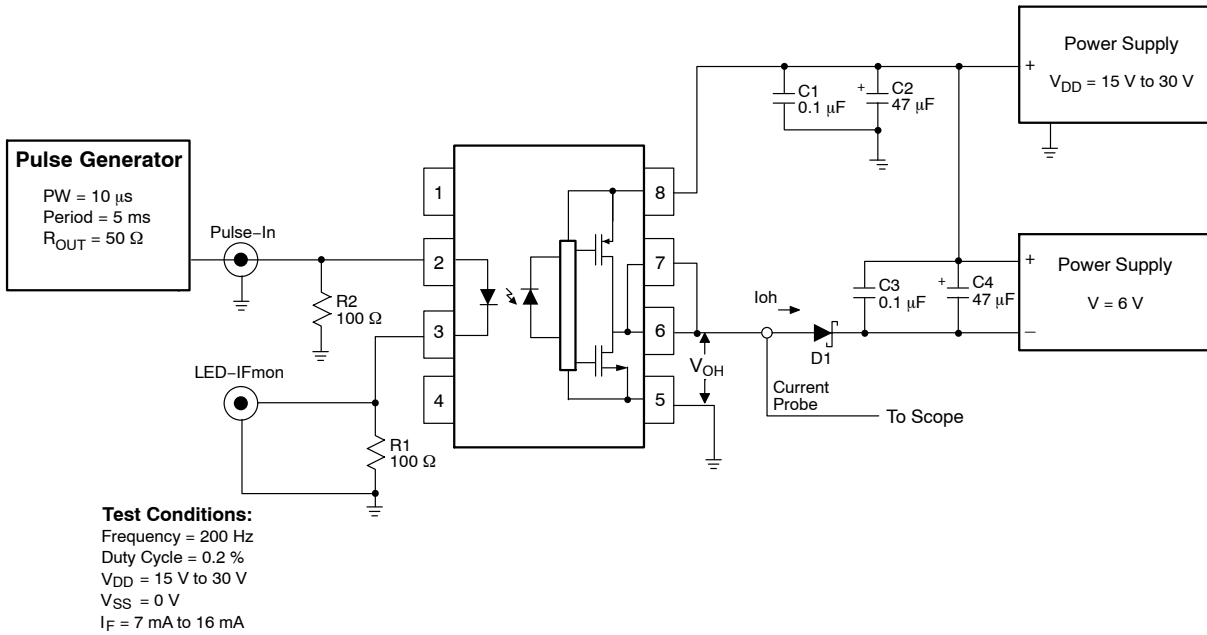

Figure 19. I_{OH} Test Circuit

FOD3125

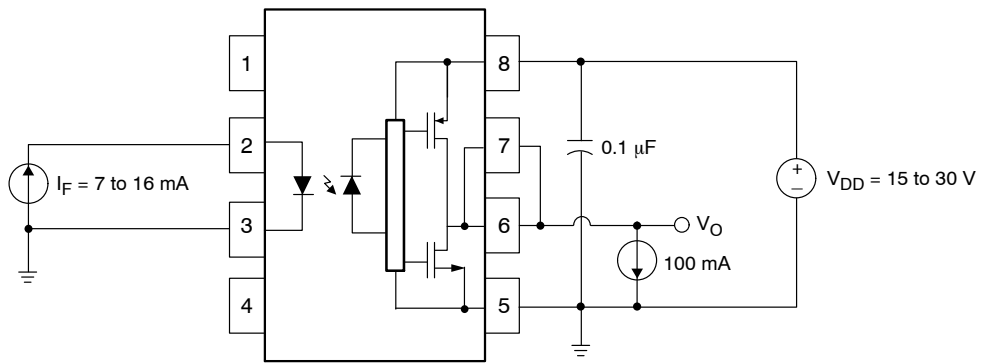

Figure 20. V_{OH} Test Circuit

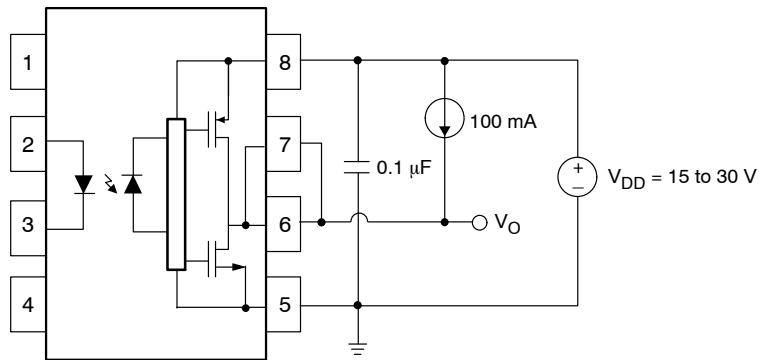

Figure 21. V_{OL} Test Circuit

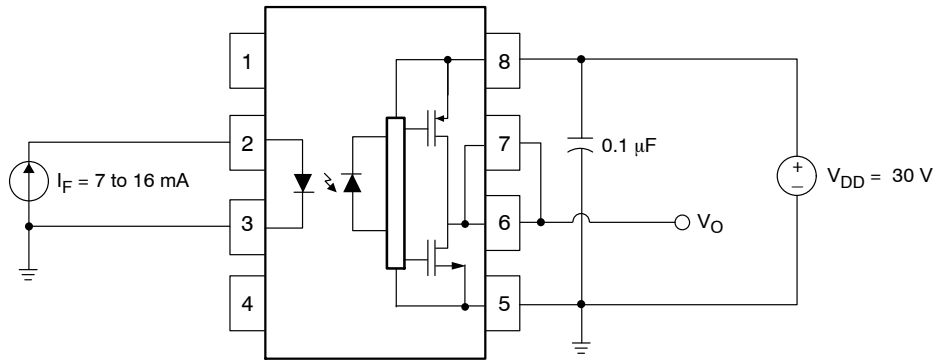

Figure 22. I_{DDH} Test Circuit

FOD3125

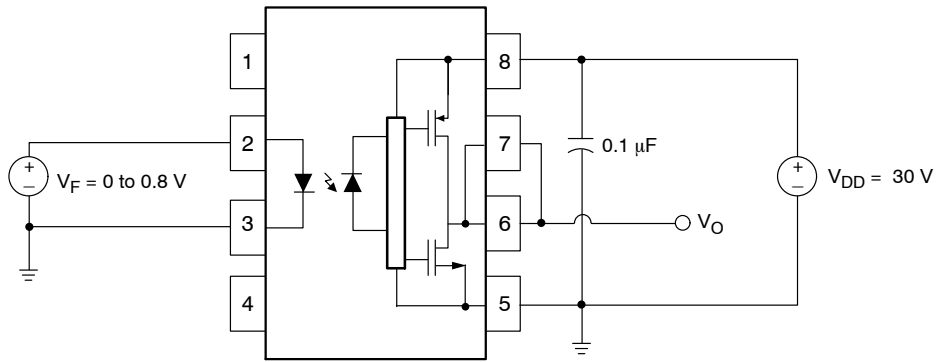

Figure 23. I_{DDL} Test Circuit

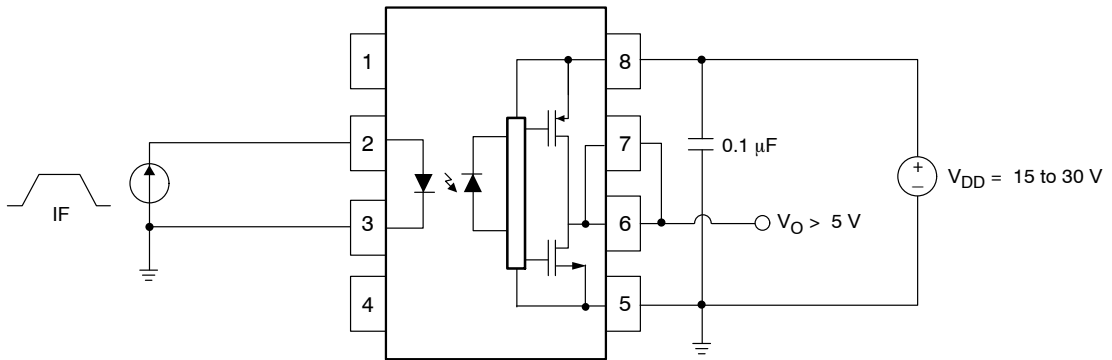

Figure 24. I_{FLH} Test Circuit

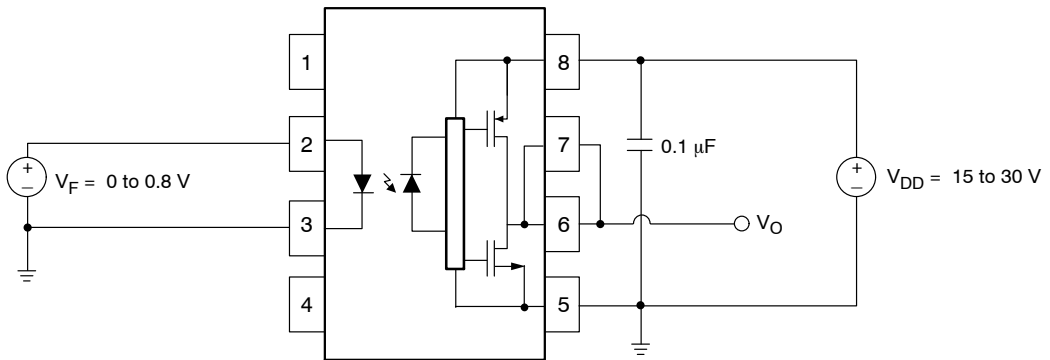

Figure 25. V_{FHL} Test Circuit

FOD3125

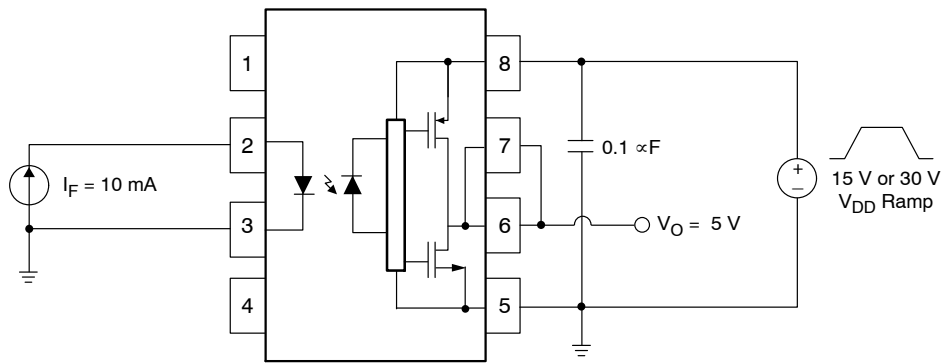

Figure 26. UVLO Test Circuit

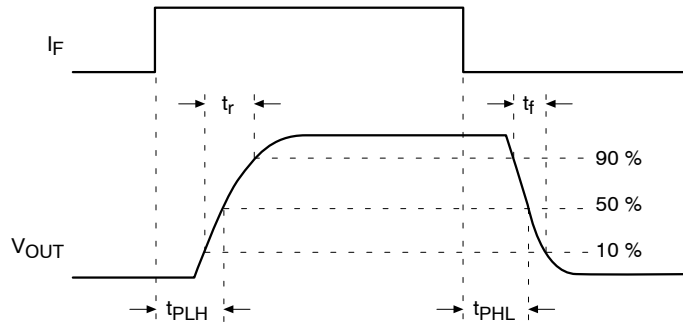
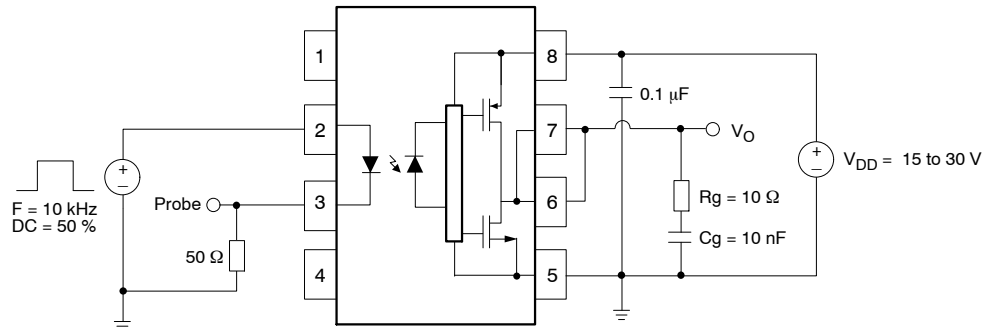

Figure 27. t_{PHL} , t_{PLH} , t_R and t_F Test Circuit and Waveforms

FOD3125

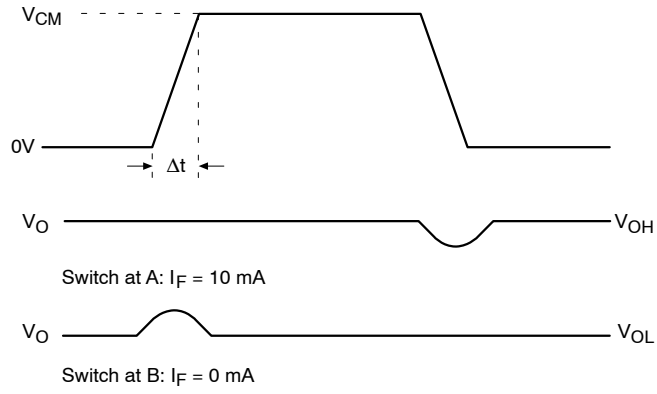
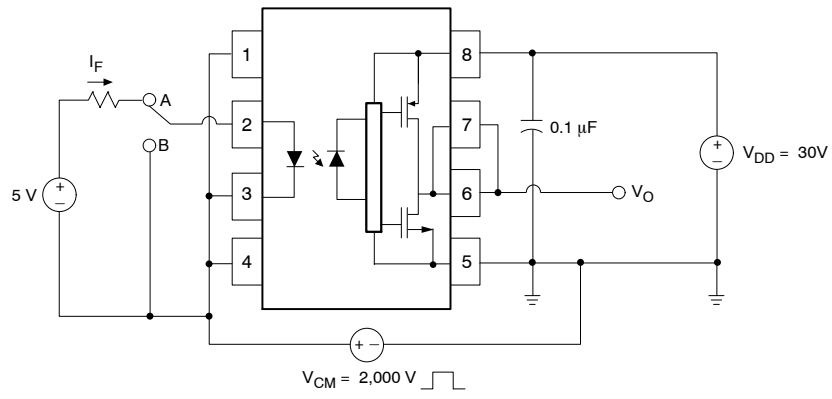
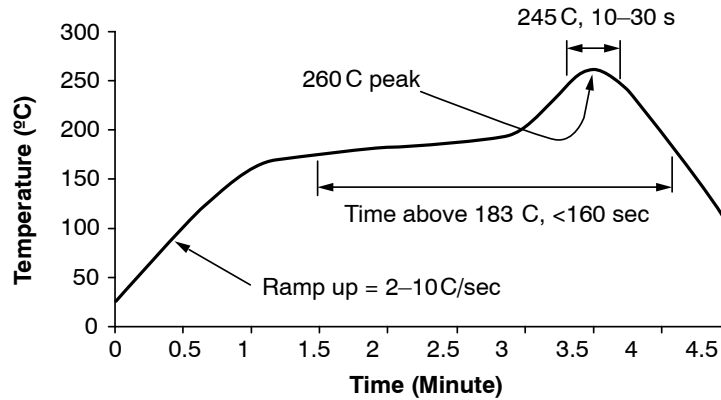

Figure 28. CMR Test Circuit and Waveforms

FOD3125

REFLOW PROFILE



Notes:

- Peak reflow temperature: 260 C (package surface temperature)
- Time of temperature higher than 183 C for 160 seconds or less
- One time soldering reflow is recommended

Figure 29. Reflow Profile

ORDERING INFORMATION

| Part Number | Package | Shipping [†] |
|--------------|--|-----------------------|
| FOD3125 | DIP 8-Pin | 50 / Tube |
| FOD3125S | SMT 8-Pin (Lead Bend) | 50 / Tube |
| FOD3125SD | SMT 8-Pin (Lead Bend) | 1,000 / Tape & Reel |
| FOD3125V | DIP 8-Pin, DIN EN/IEC 60747-5-5 option (pending approval) | 50 / Tube |
| FOD3125SV | SMT 8-Pin (Lead Bend), DIN EN/IEC 60747-5-5 option (pending approval) | 50 / Tube |
| FOD3125SDV | SMT 8-Pin (Lead Bend), DIN EN/IEC 60747-5-5 option (pending approval) | 1,000 / Tape & Reel |
| FOD3125TV | DIP 8-Pin, 0.4" Lead Spacing, DIN EN/IEC 60747-5-5 option (pending approval) | 50 / Tube |
| FOD3125TSV | SMT 8-Pin, 0.4" Lead Spacing, DIN EN/IEC 60747-5-5 option (pending approval) | 50 / Tube |
| FOD3125TSR2V | SMT 8-Pin, 0.4" Lead Spacing, DIN EN/IEC 60747-5-5 option (pending approval) | 1,000 / Tape & Reel |

[†] For information on tape and reel specifications, including part orientation and tape sizes, please refer to our Tape and Reel Packaging Specifications Brochure, [BRD8011/D](#).

MARKING INFORMATION

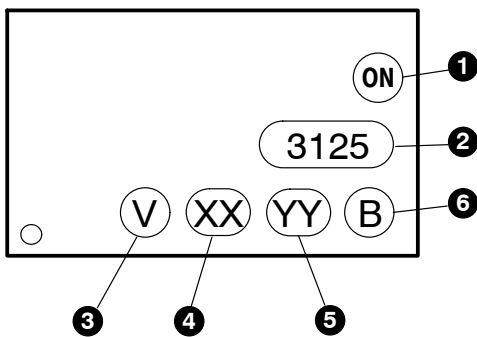

Figure 30. Device Marking

| Definitions | |
|-------------|--|
| 1 | Company logo |
| 2 | Device number |
| 3 | DIN EN/IEC60747-5-5 Option (pending approval) (only appears on component ordered with this option) |
| 4 | Two digit year code, e.g., '19' |
| 5 | Two digit work week ranging from '01' to '53' |
| 6 | Assembly package code |

CARRIER TAPE SPECIFICATIONS (OPTION SD)

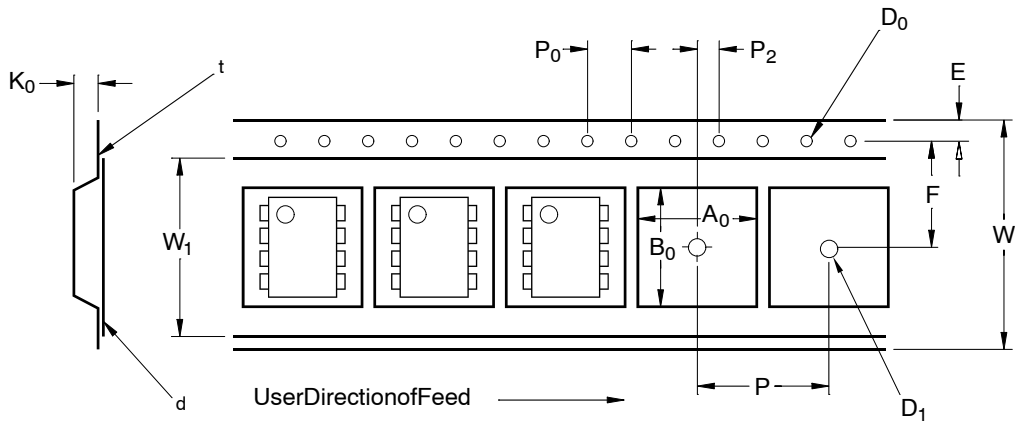

Figure 31. Carrier Tape Specifications

| Symbol | Description | Dimension in mm |
|----------------|---------------------------------|-----------------|
| W | Tape Width | 16.0 ± 0.3 |
| t | Tape Thickness | 0.30 ± 0.05 |
| P ₀ | Sprocket Hole Pitch | 4.0 ± 0.1 |
| D ₀ | Sprocket Hole Diameter | 1.55 ± 0.05 |
| E | Sprocket Hole Location | 1.75 ± 0.10 |
| F | Pocket Location | 7.5 ± 0.1 |
| P ₂ | | 2.0 ± 0.1 |
| P | Pocket Pitch | 12.0 ± 0.1 |
| A ₀ | Pocket Dimensions | 10.30 ± 0.20 |
| B ₀ | | 10.30 ± 0.20 |
| K ₀ | | 4.90 ± 0.20 |
| W ₁ | Cover Tape Width | 13.2 ± 0.2 |
| d | Cover Tape Thickness | 0.1 max |
| | Max. Component Rotation or Tilt | 10° |
| R | Min. Bending Radius | 30 |

FOD3125

REVISION HISTORY

| Revision | Description of Changes | Date |
|----------|---|------------|
| 3 | Rebranded the Data Sheet to onsemi format. | 09/05/2025 |

This document has undergone updates prior to the inclusion of this revision history table. The changes tracked here only reflect updates made on the noted approval dates.

FOD3125

PACKAGE DIMENSIONS (OPTION TS)

PDIP8 GW
CASE 709AD
ISSUE O

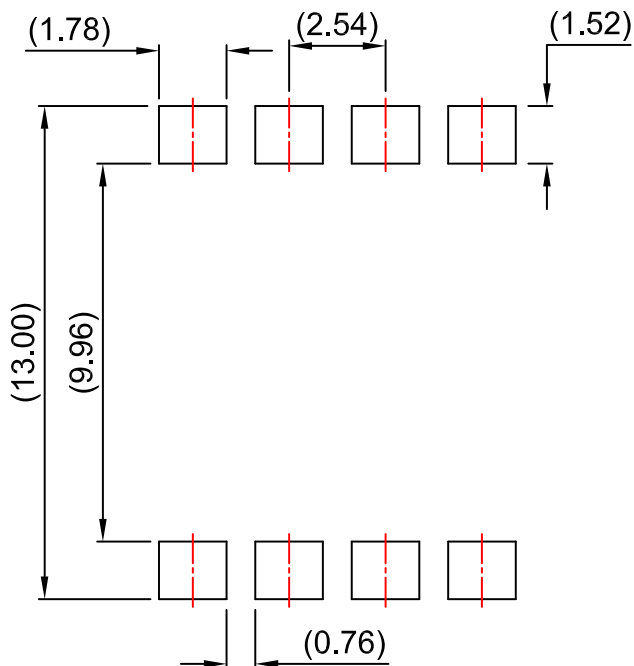
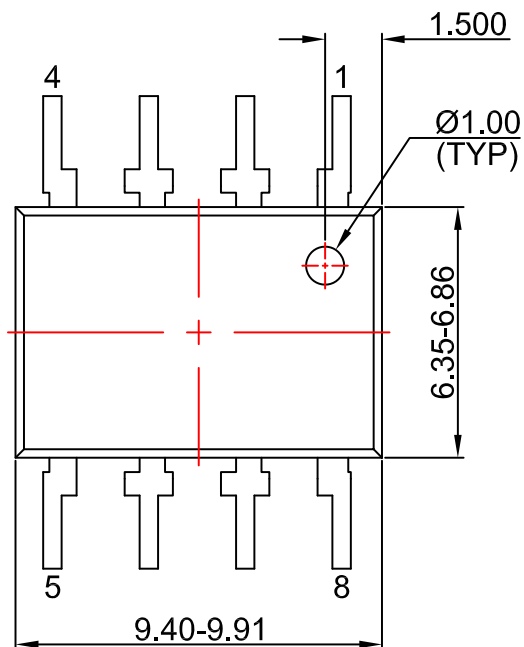

LAND PATTERN RECOMMENDATION

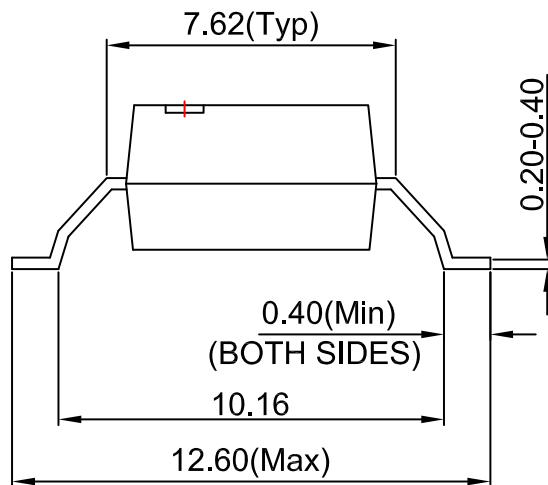
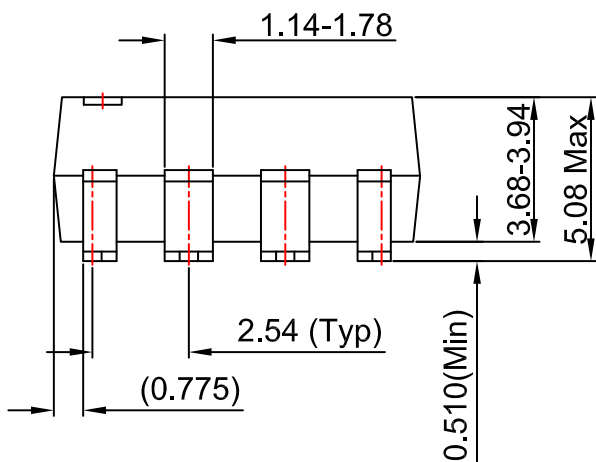

NOTES:

- A) NO STANDARD APPLIES TO THIS PACKAGE
- B) ALL DIMENSIONS ARE IN MILLIMETERS.
- C) DIMENSIONS ARE EXCLUSIVE OF BURRS, MOLD FLASH, AND TIE BAR EXTRUSION

FOD3125

PACKAGE DIMENSIONS (OPTION T)

PDIP8 6.6x3.81, 2.54P
CASE 646BW
ISSUE O

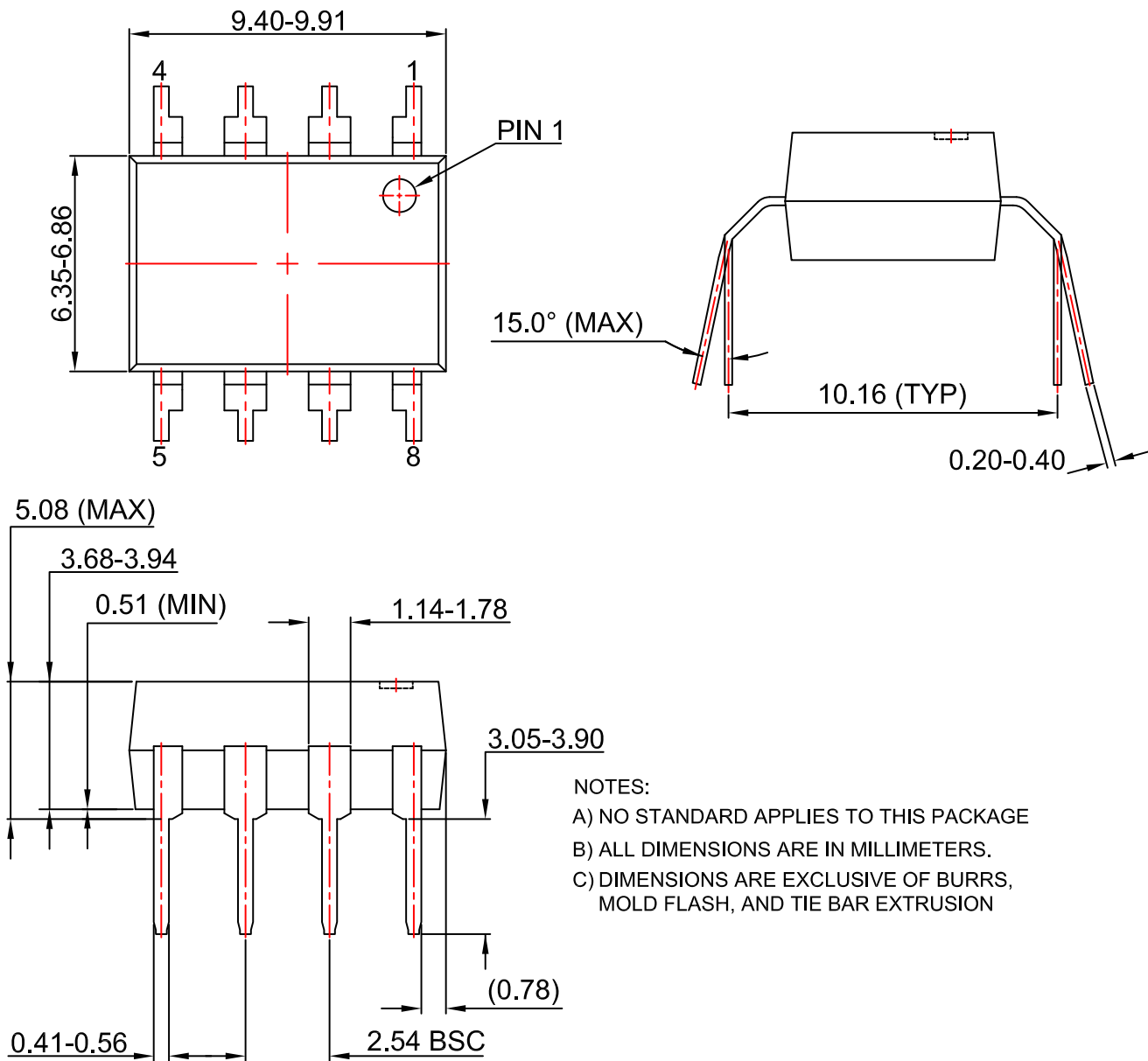

NOTES:
A) NO STANDARD APPLIES TO THIS PACKAGE
B) ALL DIMENSIONS ARE IN MILLIMETERS.
C) DIMENSIONS ARE EXCLUSIVE OF BURRS,
MOLD FLASH, AND TIE BAR EXTRUSION

PDIP8 9.655x6.6, 2.54P
CASE 646CQ
ISSUE O

DATE 18 SEP 2017

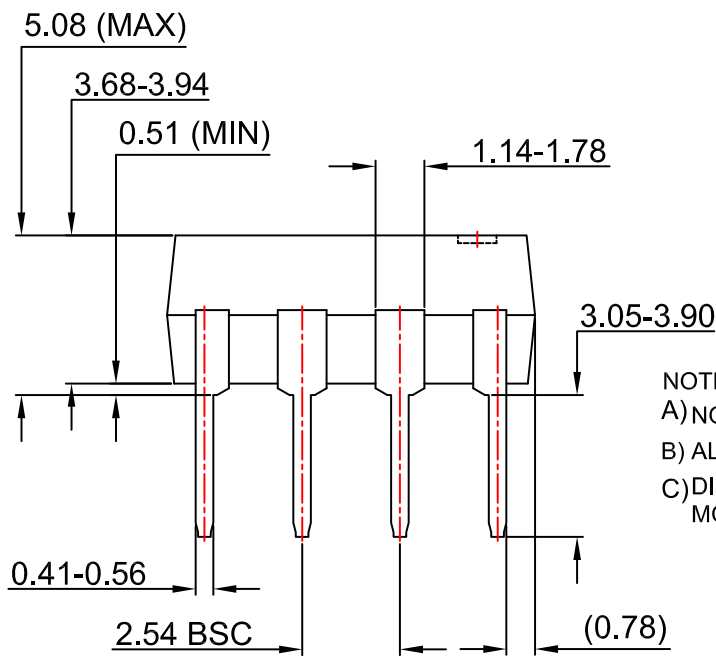
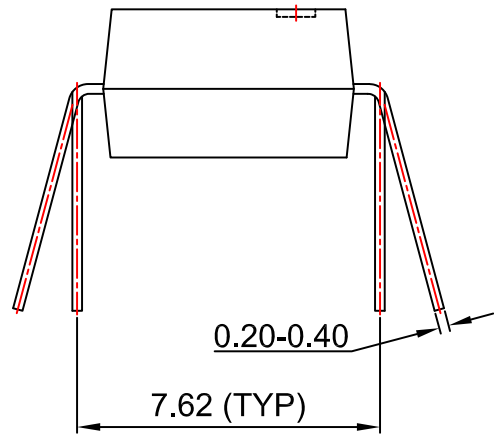
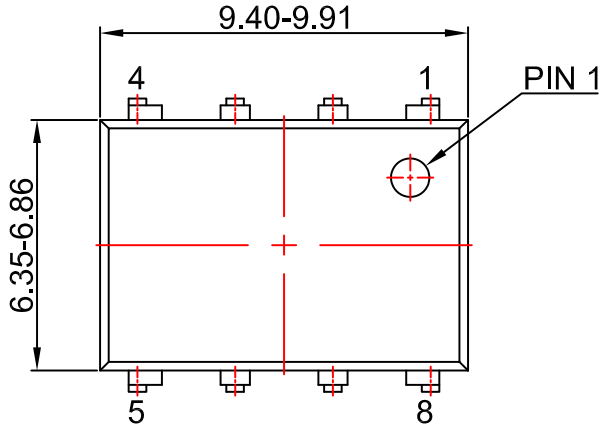

NOTES:
A) NO STANDARD APPLIES TO THIS PACKAGE
B) ALL DIMENSIONS ARE IN MILLIMETERS.
C) DIMENSIONS ARE EXCLUSIVE OF BURRS, MOLD FLASH, AND TIE BAR EXTRUSION

| | | |
|-------------------------|-------------------------------|--|
| DOCUMENT NUMBER: | 98AON13446G | Electronic versions are uncontrolled except when accessed directly from the Document Repository. Printed versions are uncontrolled except when stamped "CONTROLLED COPY" in red. |
| DESCRIPTION: | PDIP8 9.655X6.6, 2.54P | PAGE 1 OF 1 |

onsemi and ONSEMI are trademarks of Semiconductor Components Industries, LLC dba onsemi or its subsidiaries in the United States and/or other countries. onsemi reserves the right to make changes without further notice to any products herein. onsemi makes no warranty, representation or guarantee regarding the suitability of its products for any particular purpose, nor does onsemi assume any liability arising out of the application or use of any product or circuit, and specifically disclaims any and all liability, including without limitation special, consequential or incidental damages. onsemi does not convey any license under its patent rights nor the rights of others.

PDIP8 GW
CASE 709AC
ISSUE O

DATE 31 JUL 2016

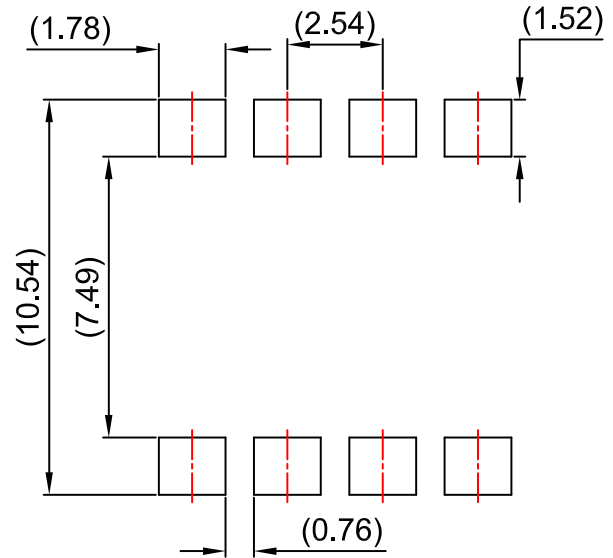
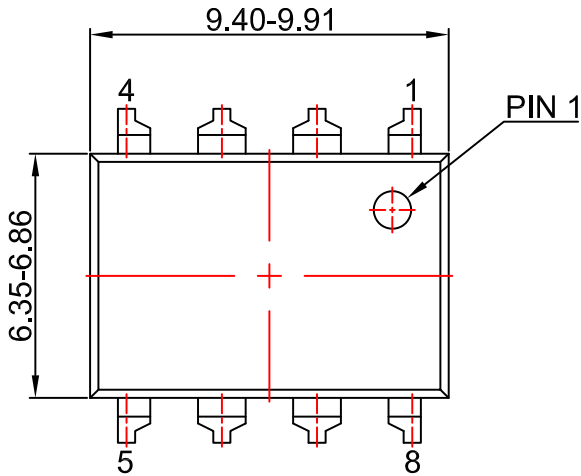

LAND PATTERN RECOMMENDATION

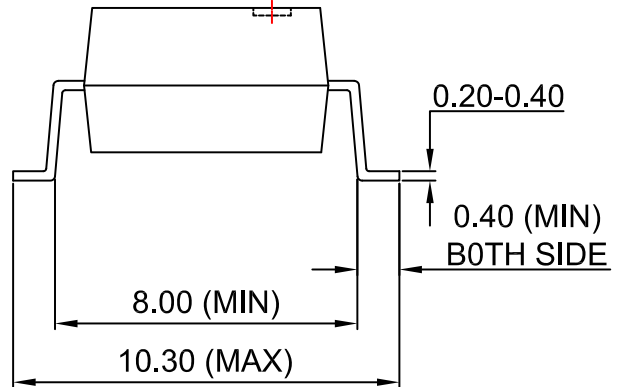
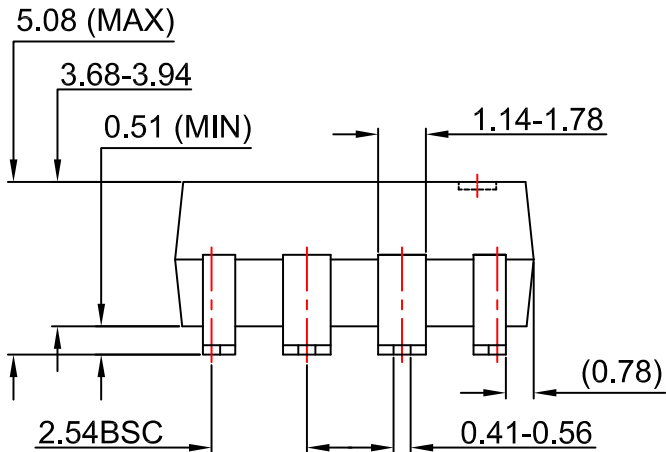

NOTES:

- A) NO STANDARD APPLIES TO THIS PACKAGE
- B) ALL DIMENSIONS ARE IN MILLIMETERS.
- C) DIMENSIONS ARE EXCLUSIVE OF BURRS, MOLD FLASH, AND TIE BAR EXTRUSION

| | | |
|-------------------------|--------------------|---|
| DOCUMENT NUMBER: | 98AON13447G | Electronic versions are uncontrolled except when accessed directly from the Document Repository. Printed versions are uncontrolled except when stamped "CONTROLLED COPY" in red. |
| DESCRIPTION: | PDIP8 GW | PAGE 1 OF 1 |

onsemi and ONSEMI are trademarks of Semiconductor Components Industries, LLC dba onsemi or its subsidiaries in the United States and/or other countries. onsemi reserves the right to make changes without further notice to any products herein. onsemi makes no warranty, representation or guarantee regarding the suitability of its products for any particular purpose, nor does onsemi assume any liability arising out of the application or use of any product or circuit, and specifically disclaims any and all liability, including without limitation special, consequential or incidental damages. onsemi does not convey any license under its patent rights nor the rights of others.

onsemi, **Onsemi**, and other names, marks, and brands are registered and/or common law trademarks of Semiconductor Components Industries, LLC dba "**onsemi**" or its affiliates and/or subsidiaries in the United States and/or other countries. **onsemi** owns the rights to a number of patents, trademarks, copyrights, trade secrets, and other intellectual property. A listing of **onsemi**'s product/patent coverage may be accessed at www.onsemi.com/site/pdf/Patent-Marking.pdf. **onsemi** reserves the right to make changes at any time to any products or information herein, without notice. The information herein is provided "as-is" and **onsemi** makes no warranty, representation or guarantee regarding the accuracy of the information, product features, availability, functionality, or suitability of its products for any particular purpose, nor does **onsemi** assume any liability arising out of the application or use of any product or circuit, and specifically disclaims any and all liability, including without limitation special, consequential or incidental damages. Buyer is responsible for its products and applications using **onsemi** products, including compliance with all laws, regulations and safety requirements or standards, regardless of any support or applications information provided by **onsemi**. "Typical" parameters which may be provided in **onsemi** data sheets and/or specifications can and do vary in different applications and actual performance may vary over time. All operating parameters, including "Typicals" must be validated for each customer application by customer's technical experts. **onsemi** does not convey any license under any of its intellectual property rights nor the rights of others. **onsemi** products are not designed, intended, or authorized for use as a critical component in life support systems or any FDA Class 3 medical devices or medical devices with a same or similar classification in a foreign jurisdiction or any devices intended for implantation in the human body. Should Buyer purchase or use **onsemi** products for any such unintended or unauthorized application, Buyer shall indemnify and hold **onsemi** and its officers, employees, subsidiaries, affiliates, and distributors harmless against all claims, costs, damages, and expenses, and reasonable attorney fees arising out of, directly or indirectly, any claim of personal injury or death associated with such unintended or unauthorized use, even if such claim alleges that **onsemi** was negligent regarding the design or manufacture of the part. **onsemi** is an Equal Opportunity/Affirmative Action Employer. This literature is subject to all applicable copyright laws and is not for resale in any manner.

ADDITIONAL INFORMATION

TECHNICAL PUBLICATIONS:

Technical Library: www.onsemi.com/design/resources/technical-documentation
onsemi Website: www.onsemi.com

ONLINE SUPPORT: www.onsemi.com/support

For additional information, please contact your local Sales Representative at www.onsemi.com/support/sales