



11A, 650V SUPER JUNCTION MOS POWER TRANSISTOR

DESCRIPTION

SVSP11N65D/F/S/FJD/K/TD2 is an N-channel enhancement mode high voltage power MOSFETs produced using Silan's super junction MOS technology. It achieves low conduction loss and switching losses. It leads the design engineers to their power converters with high efficiency, high power density, and superior thermal behavior. Furthermore, it's universal applicable, i.e., suitable for hard and soft switching topologies.

FEATURES

- ◆ 11A,650V, $R_{DS(on)(typ.)}=0.33\Omega @ V_{GS}=10V$
- ◆ New revolutionary high voltage technology
- ◆ Ultra low gate charge
- ◆ Periodic avalanche rated
- ◆ Extreme dv/dt rated
- ◆ High peak current capability

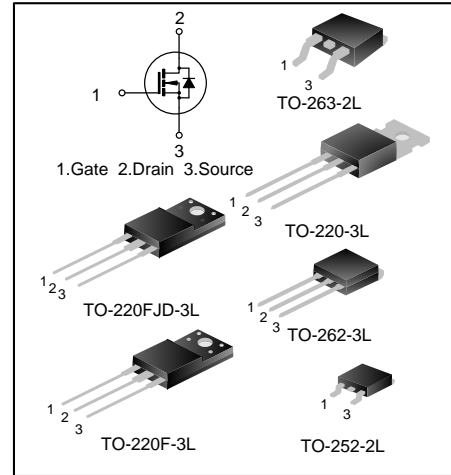

ORDERING INFORMATION

Part No.	Package	Marking	Hazardous Substance Control	Packing Type
SVSP11N65DD2TR	TO-252-2L	P11N65D	Halogen free	Tape & Reel
SVSP11N65FD2	TO-220F-3L	P11N65FD2	Halogen free	Tube
SVSP11N65SD2	TO-263-2L	P11N65SD2	Halogen free	Tube
SVSP11N65SD2TR	TO-263-2L	P11N65SD2	Halogen free	Tape & Reel
SVSP11N65FJDD2	TO-220FJD-3L	P11N65FJD	Halogen free	Tube
SVSP11N65KD2	TO-262-3L	P11N65KD2	Halogen free	Tube
SVSP11N65TD2	TO-220-3L	P11N65TD2	Halogen free	Tube



ABSOLUTE MAXIMUM RATINGS (UNLESS OTHERWISE NOTED, T_A=25°C)

Characteristics	Symbol	Ratings			Unit
		SVSP11N65 DD2	SVSP11N65 F/FJDD2	SVSP11N65 S/K/TD2	
Drain-Source Voltage	V _{DS}	650			V
Gate-Source Voltage	V _{GS}	±30			V
Drain Current	I _D	T _C =25°C			A
		T _C =100°C			
Drain Current Pulsed	I _{DM}	44			A
Power Dissipation (T _C =25°C) -Derate above 25°C	P _D	87	35	92	W
		0.70	0.28	0.74	W/°C
Single Pulsed Avalanche Energy (Note 1)	E _{AS}	250			mJ
Reverse diode dv/dt (Note 2)	dv/dt	15			V/ns
MOSFET dv/dt ruggedness (Note 3)	dv/dt	50			V/ns
Operation Junction Temperature Range	T _J	-55~+150			°C
Storage Temperature Range	T _{stg}	-55~+150			°C

THERMAL CHARACTERISTICS

Characteristics	Symbol	Ratings			Unit
		SVSP11N65 DD2	SVSP11N65 F/FJDD2	SVSP11N65 S/K/TD2	
Thermal Resistance, Junction-to-Case	R _{θJC}	1.44	3.57	1.36	°C/W
Thermal Resistance, Junction-to-Ambient	R _{θJA}	62.0	62.5	62.50	°C/W



ELECTRICAL CHARACTERISTICS (UNLESS OTHERWISE NOTED, $T_J=25^{\circ}\text{C}$)

Characteristics	Symbol	Test conditions	Min.	Typ.	Max.	Unit
Drain -Source Breakdown Voltage	BV_{DSS}	$V_{GS}=0V, I_D=250\mu A$	650	--	--	V
Drain-Source Leakage Current	I_{DSS}	$V_{DS}=650V, V_{GS}=0V$	--	--	1.0	μA
Gate-Source Leakage Current	I_{GSS}	$V_{GS}=\pm 30V, V_{DS}=0V$	--	--	± 100	nA
Gate Threshold Voltage	$V_{GS(th)}$	$V_{GS}=V_{DS}, I_D=250\mu A$	2.0	--	4.0	V
Static Drain- Source on State Resistance	$R_{DS(on)}$	$V_{GS}=10V, I_D=5.5A$	--	0.33	0.4	Ω
Gate resistance	R_g	$f=1\text{MHz}$	--	5.2	--	Ω
Input Capacitance	C_{iss}	$f=1\text{MHz}, V_{GS}=0V, V_{DS}=100V$	--	632	--	pF
Output Capacitance	C_{oss}		--	37	--	
Reverse Transfer Capacitance	C_{rss}		--	2.3	--	
Turn-on Delay Time	$t_{d(on)}$	$V_{DD}=325V, V_{GS}=10V, R_G=24\Omega, I_D=11A$ (Note 4,5)	--	12	--	ns
Turn-on Rise Time	t_r		--	35	--	
Turn-off Delay Time	$t_{d(off)}$		--	64	--	
Turn-off Fall Time	t_f		--	31	--	
Total Gate Charge	Q_g	$V_{DD}=520V, V_{GS}=10V, I_D=11A$ (Note 4,5)	--	23	--	nC
Gate-Source Charge	Q_{gs}		--	5.3	--	
Gate-Drain Charge	Q_{gd}		--	11	--	

SOURCE-DRAIN DIODE RATINGS AND CHARACTERISTICS

Characteristics	Symbol	Test conditions	Min.	Typ.	Max.	Unit
Continuous Source Current	I_S	Integral Reverse P-N Junction Diode in the MOSFET	--	--	11	A
Pulsed Source Current	I_{SM}		--	--	44	
Diode Forward Voltage	V_{SD}	$I_S=11A, V_{GS}=0V$	--	--	1.4	V
Reverse Recovery Time	T_{rr}	$I_S=11A, V_{GS}=0V, dI_f/dt=100A/\mu s$ (Note 4)	--	361	--	ns
Reverse Recovery Charge	Q_{rr}		--	3.9	--	μC

Notes:

1. $L=79\text{mH}, I_{AS}=2.4A, V_{DD}=100V, R_G=25\Omega$, starting temperature $T_J=25^{\circ}\text{C}$;
2. $V_{DS}=0\sim 400V, I_{SD}\leq 11A, T_J=25^{\circ}\text{C}$;
3. $V_{DS}=0\sim 480V$;
4. Pulse Test: Pulse width $\leq 300\mu s$, Duty cycle $\leq 2\%$;
5. Essentially independent of operating temperature.



TYPICAL CHARACTERISTICS

Figure 1. On-Region Characteristics

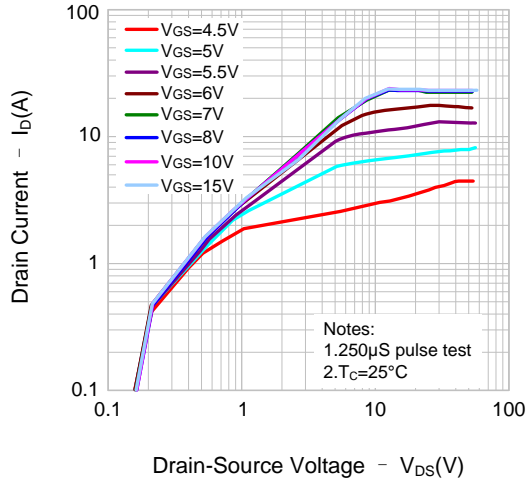

Figure 2. Transfer Characteristics

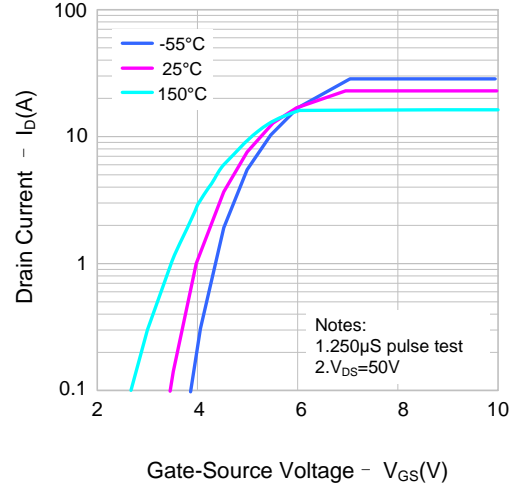

Figure 3. On-Resistance Variation vs. Drain Current

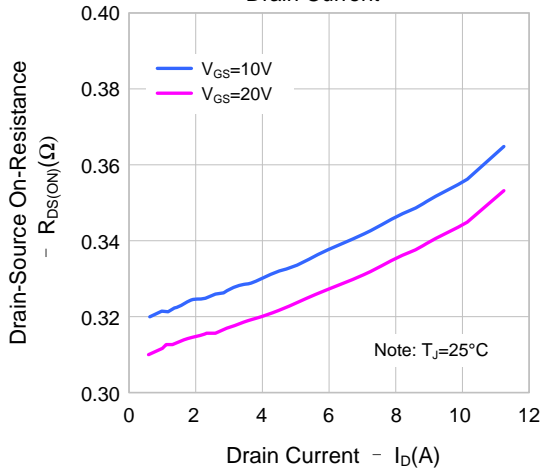

Figure 4. Body Diode Forward Voltage Variation vs. Source Current and Temperature

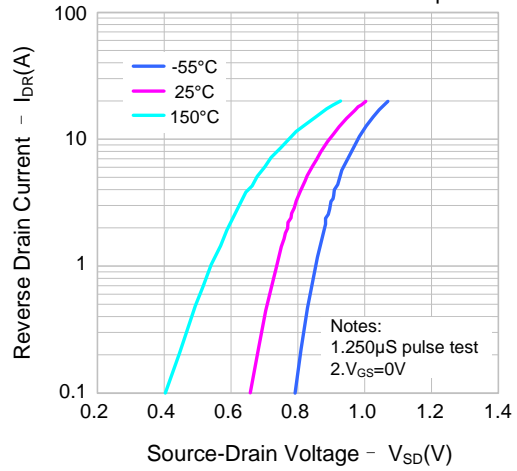

Figure 5. Capacitance Characteristics

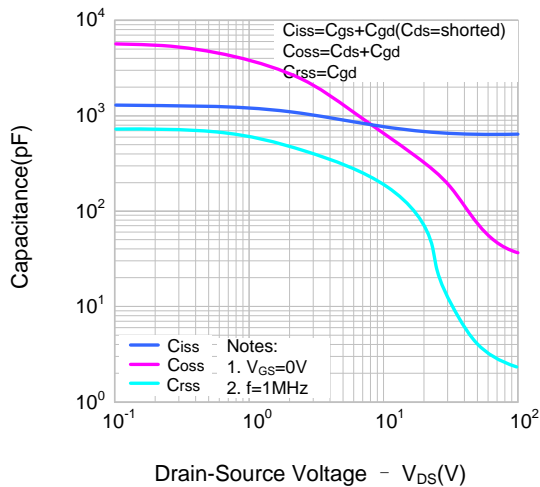
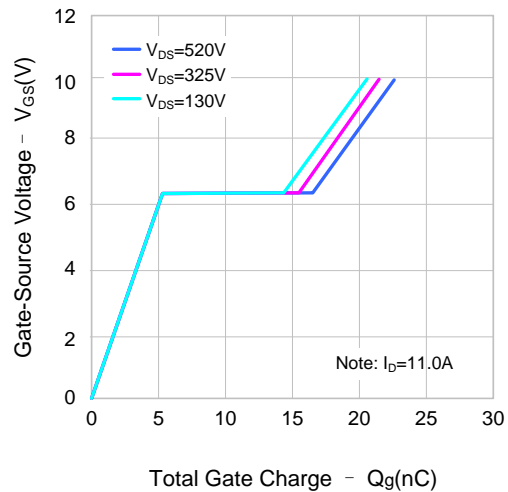

Figure 6. Gate Charge Characteristics





TYPICAL CHARACTERISTICS(CONTINUED)

Figure 7. Breakdown Voltage Variation vs. Temperature

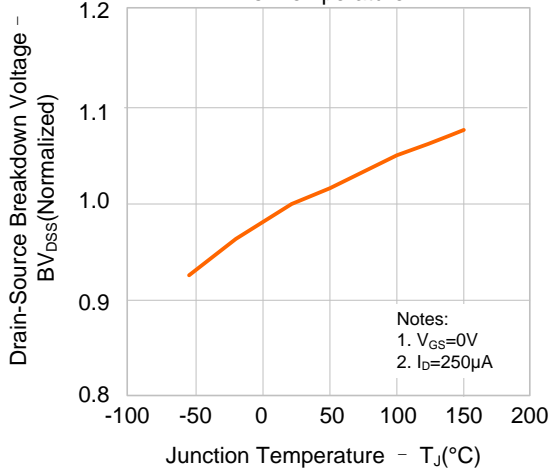

Figure 8. On-resistance Variation vs. Temperature

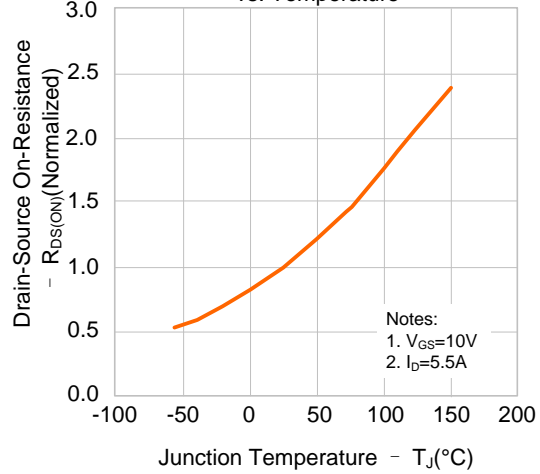

Figure 9.1. Max. Safe Operating Area(SVSP11N65DD2)

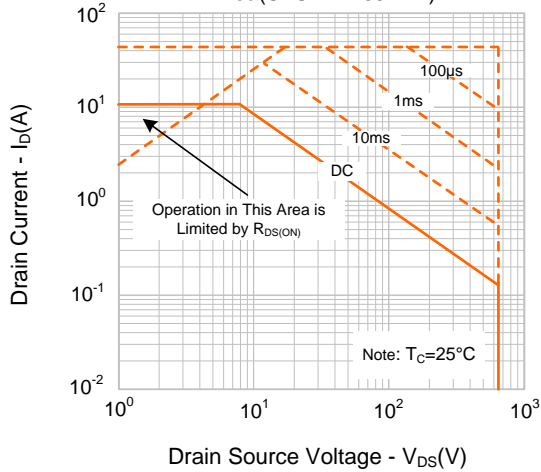

Figure 9.2. Max. Safe Operating Area(SVSP11N65F/FJDD2)

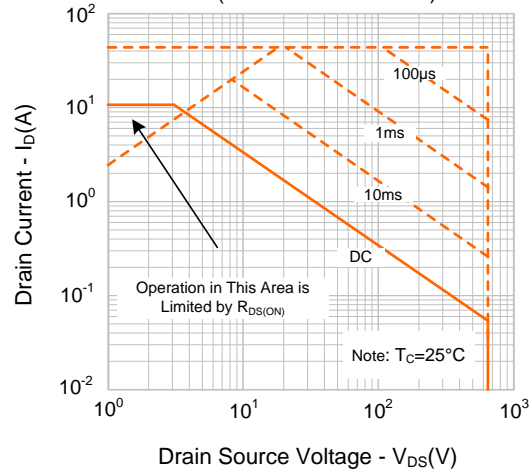
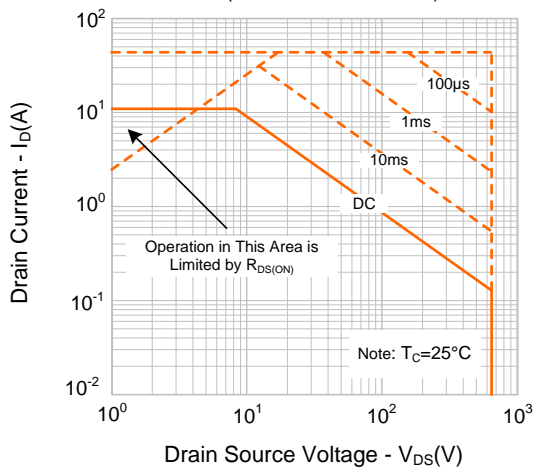
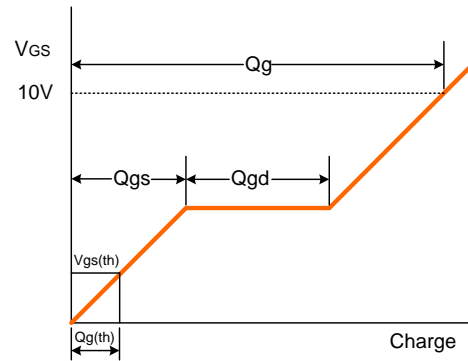
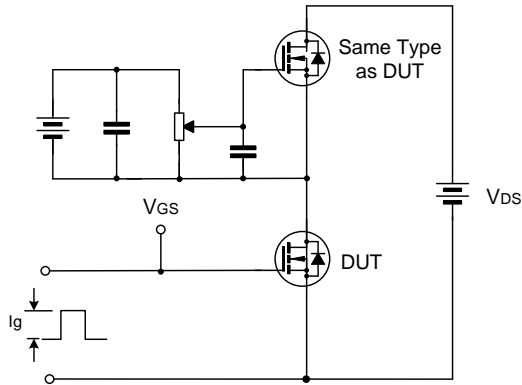

Figure 9.3. Max. Safe Operating Area(SVSP11N65S/K/TD2)





TYPICAL TEST CIRCUIT



Gate Charge Test Circuit & Waveform

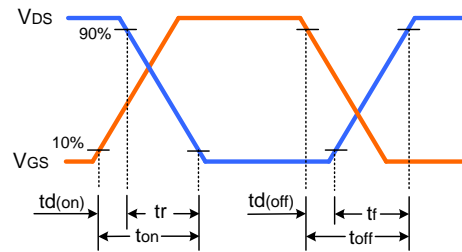
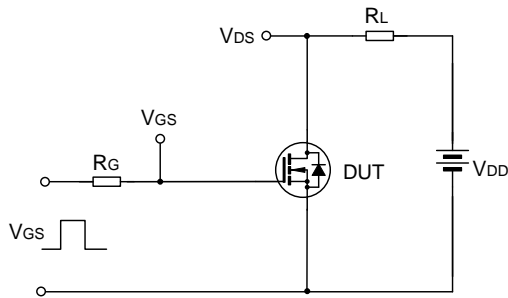

Resistive Switching Test Circuit & Waveform

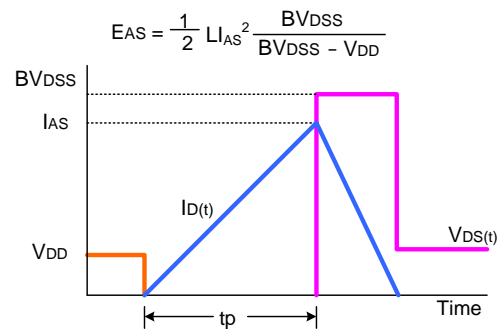
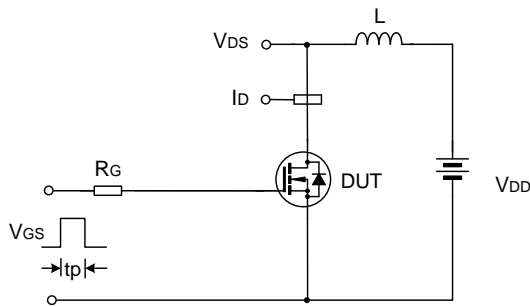

Unclamped Inductive Switching Test Circuit & Waveform



PACKAGE OUTLINE

TO-252-2L

UNIT: mm

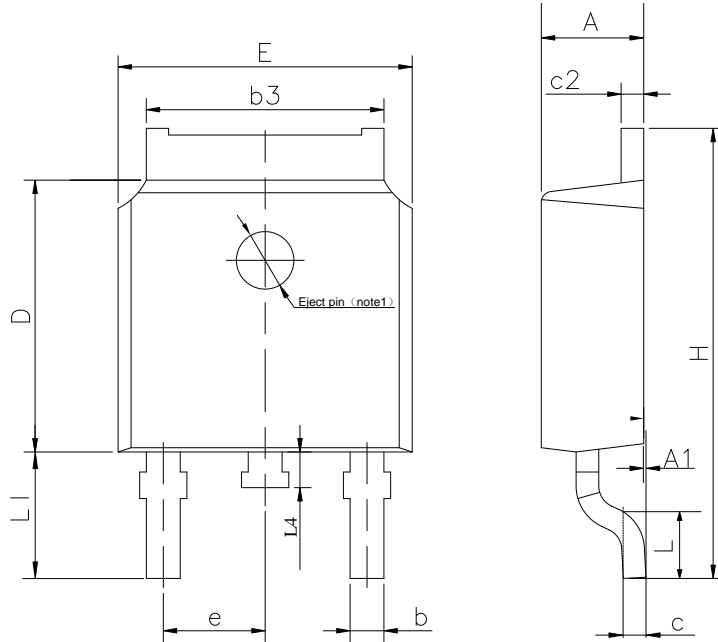

SYMBOL	MIN	NOM	MAX
A	2.10	2.30	2.50
A1	0	---	0.127
b	0.66	0.76	0.89
b3	5.10	5.33	5.46
c	0.45	---	0.65
c2	0.45	---	0.65
D	5.80	6.10	6.40
E	6.30	6.60	6.90
e	2.30TYP		
H	9.60	10.10	10.60
L	1.40	1.50	1.70
L1	2.90REF		
L4	0.60	0.80	1.00

NOTE1 : There are two conditions for this position:has an eject pin or has no eject pin.

TO-220F-3L

UNIT: mm

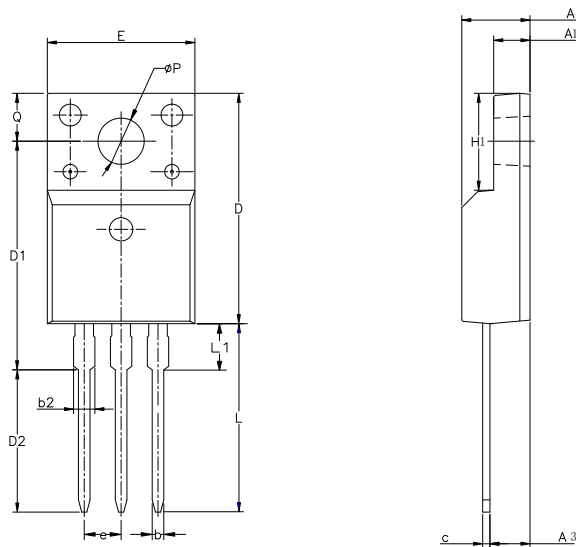

SYMBOL	MIN	NOM	MAX
A	4.42	4.70	5.02
A1	2.30	2.54	2.80
A3	2.50	2.76	3.10
b	0.70	0.80	0.90
b2	—	—	1.47
c	0.35	0.50	0.65
D	15.25	15.87	16.25
D1	15.30	15.75	16.30
D2	9.30	9.80	10.30
E	9.73	10.16	10.36
e	2.54BCS		
H1	6.40	6.68	7.00
L	12.48	12.98	13.48
L1	/	/	3.50
ϕP	3.00	3.18	3.40
Q	3.05	3.30	3.55



PACKAGE OUTLINE(CONTINUED)

TO-263-2L

UNIT: mm

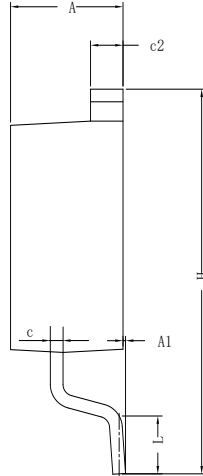
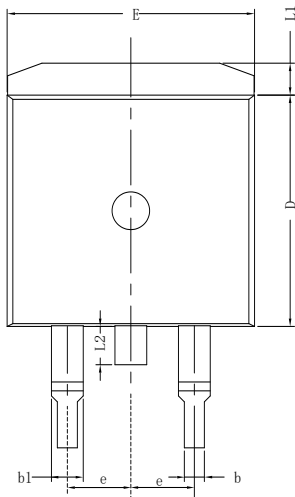

SYMBOL	MIN	NOM	MAX
A	4.30	4.57	4.72
A1	0	0.10	0.25
b	0.71	0.81	0.91
c	0.30	---	0.60
c2	1.17	1.27	1.37
D	8.50	---	9.35
E	9.80	---	10.45
e	2.54BSC		
H	14.70	---	15.75
L	2.00	2.30	2.74
L1	1.12	1.27	1.42
L2	---	---	1.75

TO-220FJD-3L

UNIT: mm

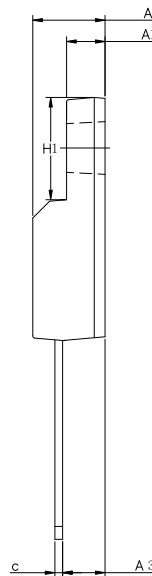
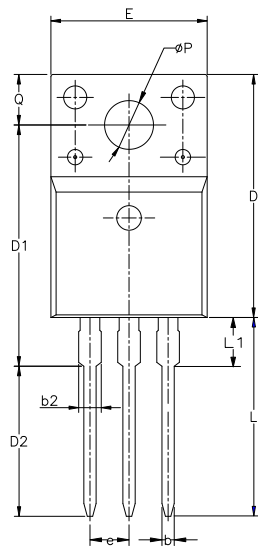

SYMBOL	MIN	NOM	MAX
A	4.42	4.70	5.02
A1	2.30	2.54	2.80
A3	2.50	2.76	3.10
b	0.55	0.70	0.85
b2	---	---	1.29
c	0.35	0.50	0.65
D	15.25	15.87	16.25
D1	13.97	14.47	14.97
D2	10.58	11.08	11.58
E	9.73	10.16	10.36
e	2.54BCS		
H1	6.40	6.68	7.00
L	12.48	12.98	13.48
L1	---	---	2.00
ØP	3.00	3.18	3.40
Q	3.05	3.30	3.55



PACKAGE OUTLINE(CONTINUED)

TO-262-3L **UNIT: mm**

SYMBOL	MIN	NOM	MAX
A	4.30	4.50	4.70
A1	2.20	---	2.92
b	0.71	0.80	0.90
b2	1.20	---	1.50
c	0.34	---	0.65
c2	1.22	1.30	1.35
D	8.38	---	9.30
E	9.80	10.16	10.54
e	2.54 BSC		
L	12.80	---	14.10
L1	---	---	0.75
L2	1.12	---	1.42

TO-220-3L **UNIT: mm**

SYMBOL	MIN	NOM	MAX
A	4.30	4.50	4.70
A1	1.00	1.30	1.50
A2	1.80	2.40	2.80
b	0.60	0.80	1.00
b1	1.00	---	1.60
c	0.30	---	0.70
D	15.10	15.70	16.10
D1	8.10	9.20	10.00
E	9.60	9.90	10.40
e	2.54BSC		
H1	6.10	6.50	7.00
L	12.60	13.08	13.60
L1	---	---	3.95
phi P	3.40	3.70	3.90
Q	2.60	---	3.20



Important notice :

- The instructions are subject to change without notice! Customers should obtain the latest relevant information before placing orders and should verify that such information is complete and current.
- Our products are consumer electronic products, and / or civil electronic products.
- When using our products, please do not exceed the maximum rating of the products, otherwise the reliability of the whole machine will be affected. There is a certain possibility of failure or malfunction of any semiconductor product under specific conditions. The buyer is responsible for complying with safety standards and taking safety measures when using our products for system design, sample and whole machine manufacturing, so as to avoid potential failure risk that may cause personal injury or property loss.
- It is strongly recommended to identify the trademark when buying our products. Please contact us if there is any question.
- When exporting, using and reselling our products, buyer must comply with the international export control laws and regulations of China, the United States, the United Kingdom, the European Union and other countries & regions.
- Product promotion is endless, our company will wholeheartedly provide customers with better products!
- Website: <http://www.silan.com.cn>

Part No.: SVSP11N65D/F/S/FJD/K/TD2

Document Type: Datasheet

Copyright: HANGZHOU SILAN MICROELECTRONICS CO.,LTD

Website: <http://www.silan.com.cn>

Rev.: 1.3

Revision History:

1. Modify Electrical schematic and TYPICAL TEST CIRCUIT
-

Rev.: 1.2

Revision History:

1. Add TO-220-3L
-

Rev.: 1.1

Revision History:

1. Add TO-262-3L
-

Rev.: 1.0

Revision History:

1. First release
-
-