

## iSSI20R02H, iSSI20R03H, iSSI20R11H, iSSI30R11H, iSSI30R12H Infineon's coreless-transformer advanced solid-state isolators

### Features

- Solid-state isolators using Infineon's coreless-transformer technology
- No isolated gate bias supply required for gate driving
- Perfect match for CoolMOS™, OptiMOS™, and TRENCHSTOP™ IGBT
- Low power, large input voltage range from 2.6 V to 3.5 V (internally clamped)
- High-impedance, CMOS input (buffered variants)
- High output voltage up to 18 V - no series or parallel configuration required for powerful gate driving
- High output peak current of 175  $\mu$ A (direct drive variants) or 400 mA (buffered variants)
- Fast turn-off for safe switches' SOA operation
- Temperature sensor and current sensor protection inputs
- Latch-off in case of a failure event (overcurrent or over-temperature)
- Dynamic Miller clamping protection
- Wide-body package with high creepage and clearance for UL 1577 and reinforced isolation according to IEC 60747-17 (planned)

### Potential applications

- Solid-state relay AC and DC applications
- Electro-mechanical relay replacements
- Programmable logic control, industrial automation, and controls
- Smart building and home automation systems (thermostat, lighting, heating control)
- Instrumentation equipment



PG-DSO-8-66



PG-DSO-16-33

### Product validation

Qualified for industrial applications according to relevant tests of JEDEC47/20/22.

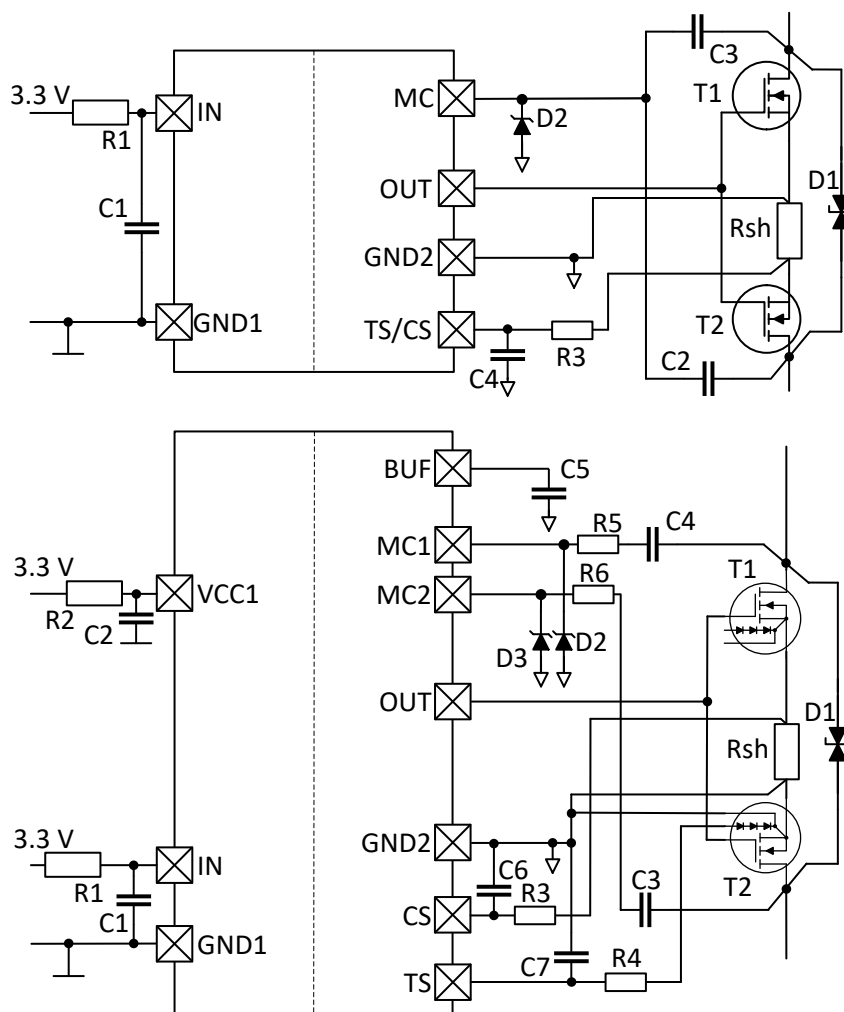
### Description

The Infineon SSI solid-state isolator family provides powerful energy transmission over a galvanic isolation barrier to drive the gates of MOS-controlled power transistors, such as CoolMOS™, OptiMOS™, or TRENCHSTOP™ IGBT. The output side of the Infineon SSI solid-state isolator family does not require a dedicated voltage supply to drive the power transistor's gate. The output side offers advanced control functions such as fast turn-on, fast turn-off, overcurrent protection and over-temperature protection to easily and safely build up solid-state relays for various applications. The Infineon SSI family includes iSSI30R12H which is tailored for CoolMOS™ S7 T-sense power MOSFETs offering an integrated temperature sensor. Other parts of the family are for use with external PTC resistors. The Infineon SSI family offers precise protection functions for building cost effective systems. The input side of the isolator is 3.3 V compatible and operates with a supply current of typically 16 mA.

The variants iSSI20R02H, iSSI20R03H, and iSSI20R11H come in a DSO-8-66 package while iSSI30R11H and iSSI30R12H come in a DSO-16-33 package.

The isolation is IEC 60747-17 (planned) certified for reinforced isolation and UL 1577 compliant.

Description



Product type	Protection features	Fast turn-on	Certification	Marking	Package
iSSI20R02H	OCP or OTP (PTC), DMC	No	IEC 60747-17, UL1577	I20R02	PG-DSO-8-66
iSSI20R03H	OCP, OTP (PTC)	No	IEC 60747-17, UL1577	I20R03	PG-DSO-8-66
iSSI20R11H	OCP or OTP (PTC)	Yes	IEC 60747-17, UL1577	I20R11	PG-DSO-8-66
iSSI30R11H	OCP, OTP (PTC), DMC	Yes	IEC 60747-17, UL1577	I30R11	PG-DSO-16-33
iSSI30R12H	OCP, OTP (diode), DMC	Yes	IEC 60747-17, UL1577	I30R12	PG-DSO-16-33

## Table of contents

	<b>Features</b> .....	1
	<b>Potential applications</b> .....	1
	<b>Product validation</b> .....	1
	<b>Description</b> .....	1
	<b>Table of contents</b> .....	3
<b>1</b>	<b>Block diagrams</b> .....	5
<b>2</b>	<b>Pin configuration</b> .....	7
2.1	Pin configuration .....	7
2.2	Pin description .....	9
<b>3</b>	<b>Electrical characteristics and parameters</b> .....	10
3.1	Absolute maximum ratings .....	10
3.2	Operating parameters .....	11
3.3	Electrical characteristics .....	12
3.3.1	IC Supply .....	12
3.3.2	Logic input (iSSI20R11H, iSSI30R11H, iSSI30R12H) .....	13
3.3.3	Gate drive .....	13
3.3.4	Fast turn-on (iSSI20R11H, iSSI30R11H, iSSI30R12H) .....	14
3.3.5	Dynamic Miller clamping .....	15
3.3.6	Over-temperature protection .....	15
3.3.7	Overcurrent protection .....	16
<b>4</b>	<b>Insulation and safety-related specification</b> .....	17
4.1	Safety-limiting values .....	17
4.2	Reinforced insulation according to IEC 60747-17 (planned) .....	17
<b>5</b>	<b>Timing diagrams</b> .....	19
<b>6</b>	<b>Functional description</b> .....	21
6.1	Input side .....	21
6.1.1	Input side supply .....	21
6.1.2	Logic input .....	21
6.2	Output side .....	21
6.2.1	Direct gate drive .....	21
6.2.2	Fast turn-on feature .....	22
6.2.3	Normal turn-off .....	22
6.2.4	Fast turn-off .....	22
6.2.5	Dynamic Miller clamping (DMC) .....	23
6.2.6	Overcurrent protection .....	23
6.2.7	Over-temperature protection .....	24

<b>7</b>	<b>Application information</b> .....	26
7.1	Adaptation of the supply voltage .....	26
7.2	Grounding reference of current and temperature sensor signals .....	27
7.3	Fast turn-on using iSSI20R11H and iSSI30R1xH .....	28
7.4	Using the overcurrent protection .....	29
7.5	Using the dynamic Miller clamping .....	30
7.6	Inductive energy clamping methods .....	31
<b>8</b>	<b>Related products</b> .....	32
<b>9</b>	<b>Package dimensions</b> .....	34
9.1	Package outline .....	34
	<b>Revision history</b> .....	36
	<b>Disclaimer</b> .....	37

## 1 Block diagrams

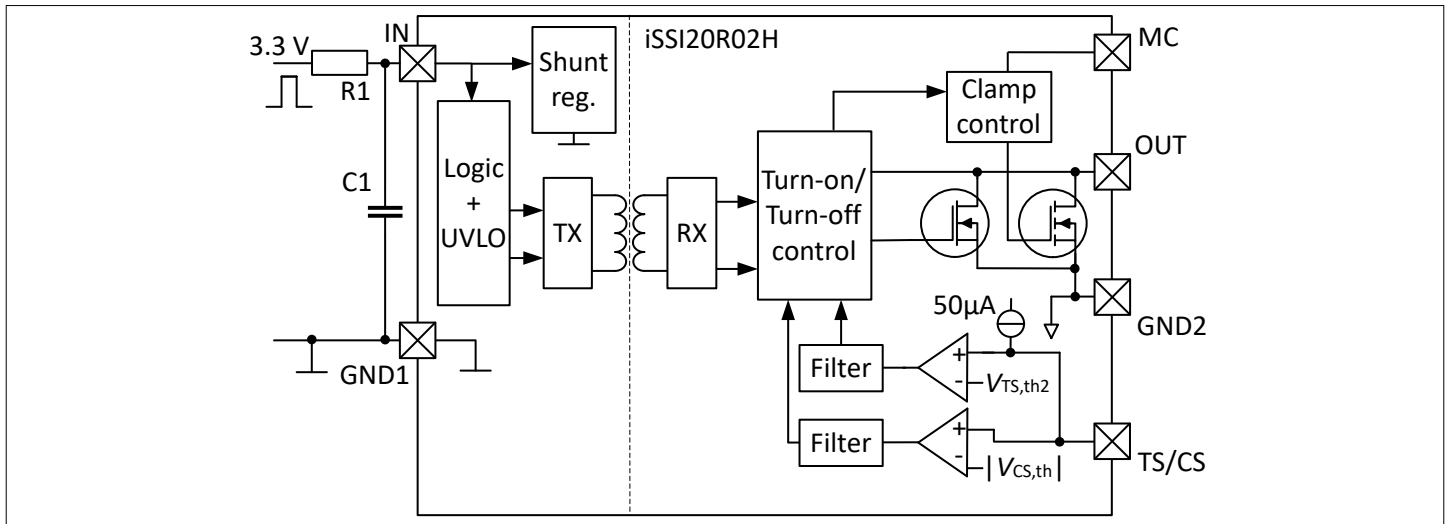


Figure 1 Block diagram of iSSI20R02H

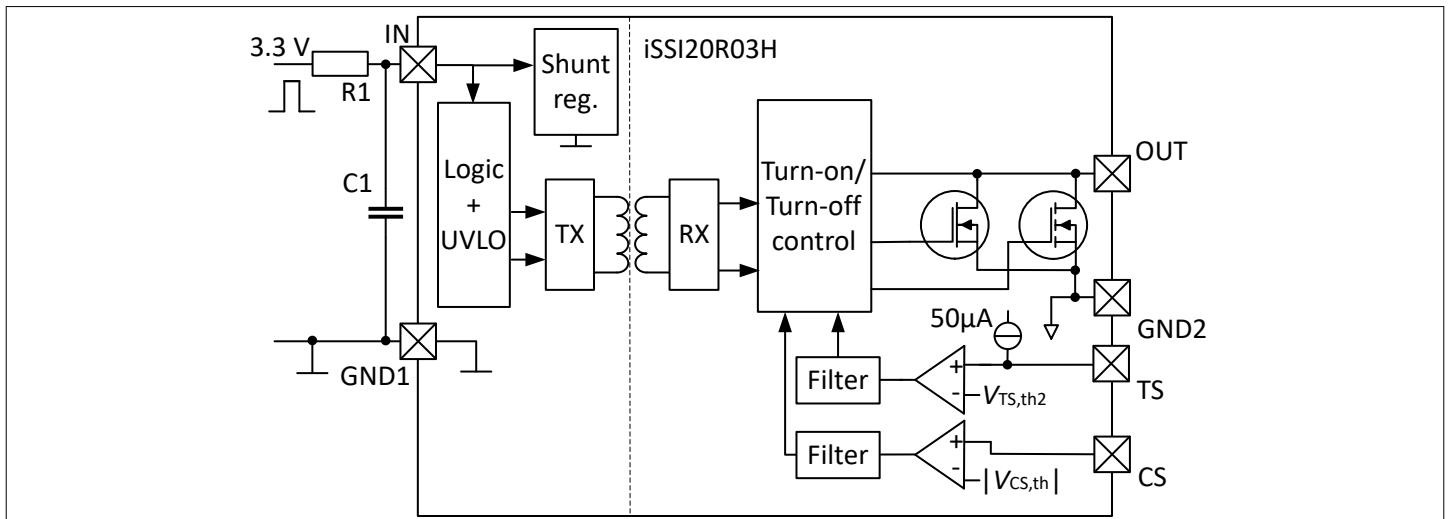


Figure 2 Block diagram of iSSI20R03H

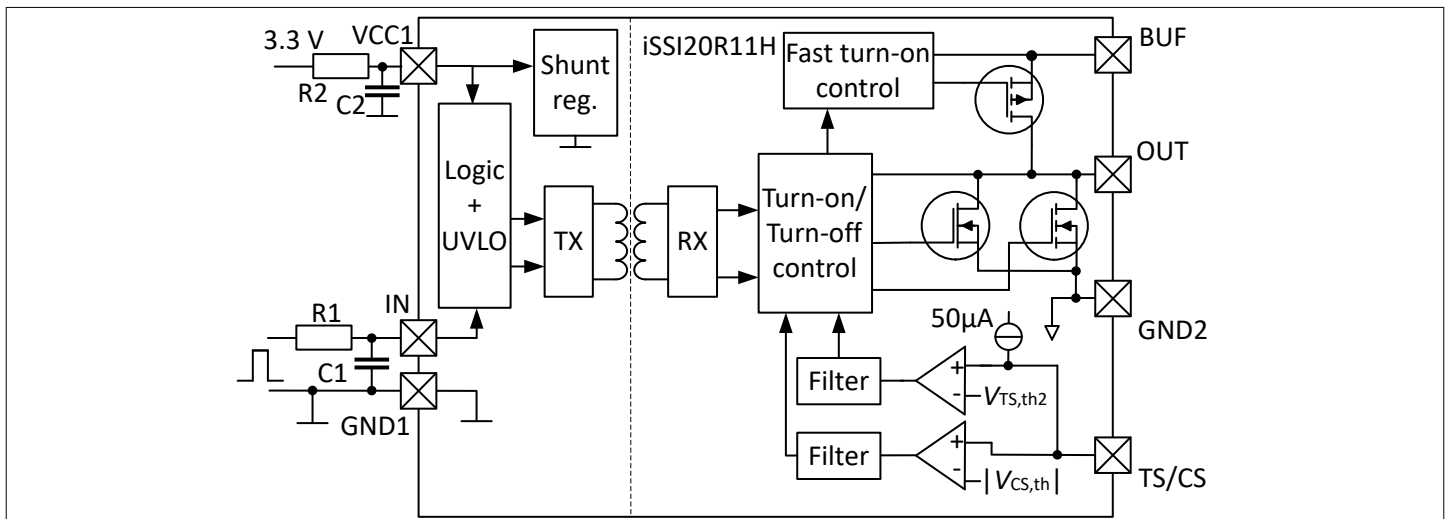


Figure 3 Block diagram of iSSI20R11H

1 Block diagrams

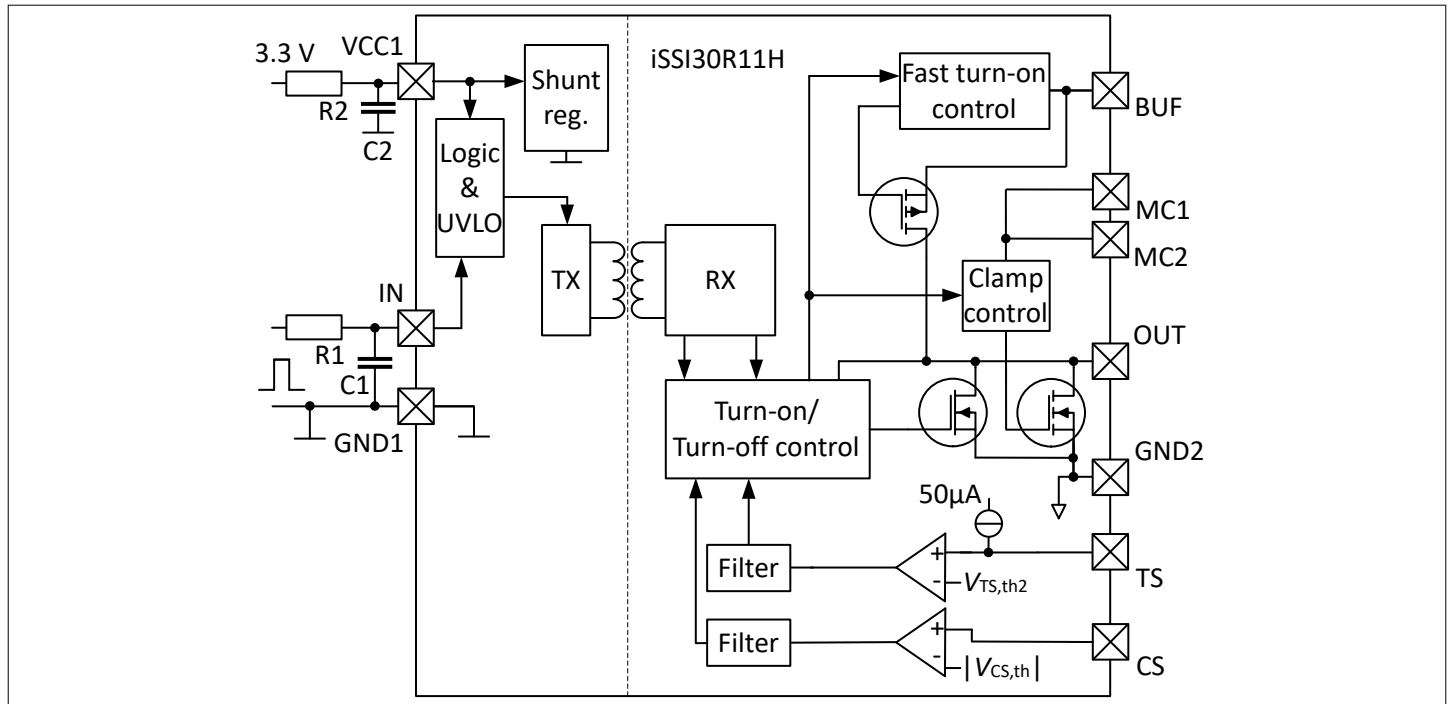


Figure 4 Block diagram of iSSI30R11H

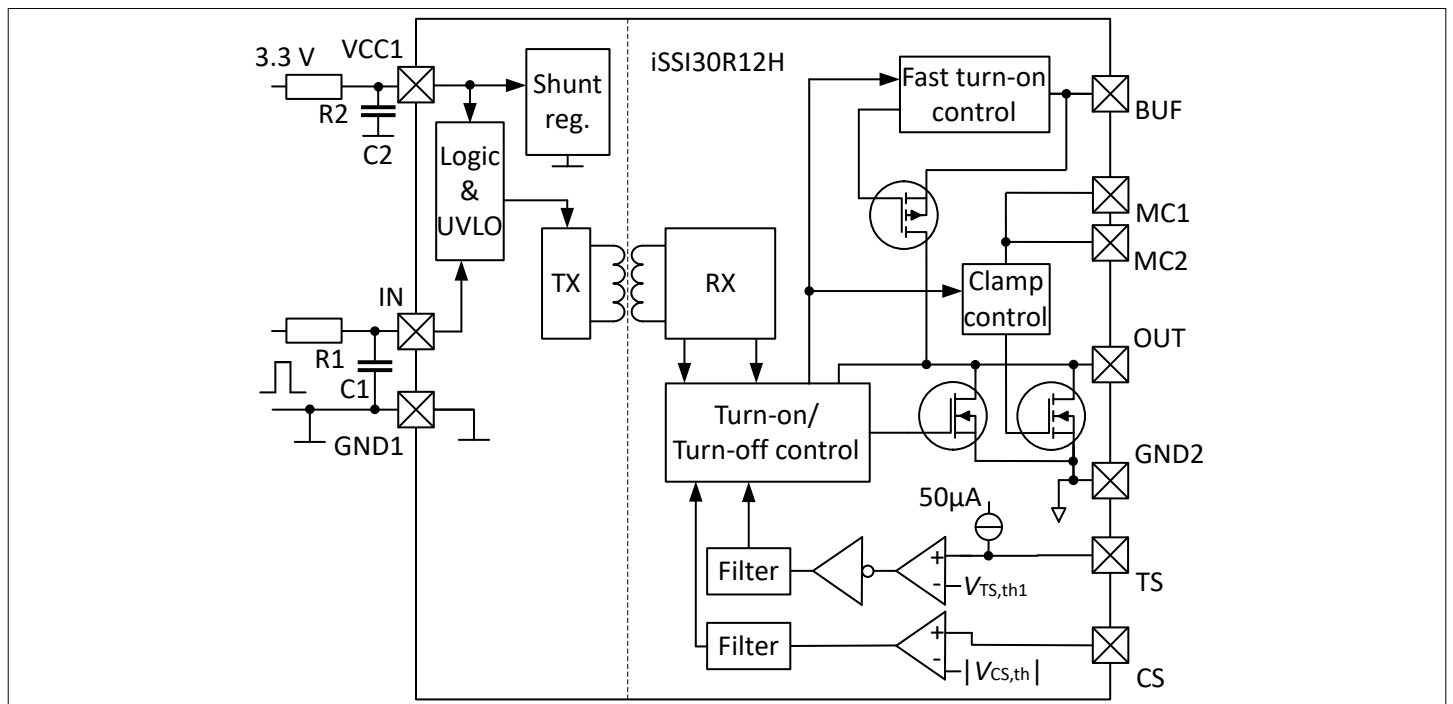
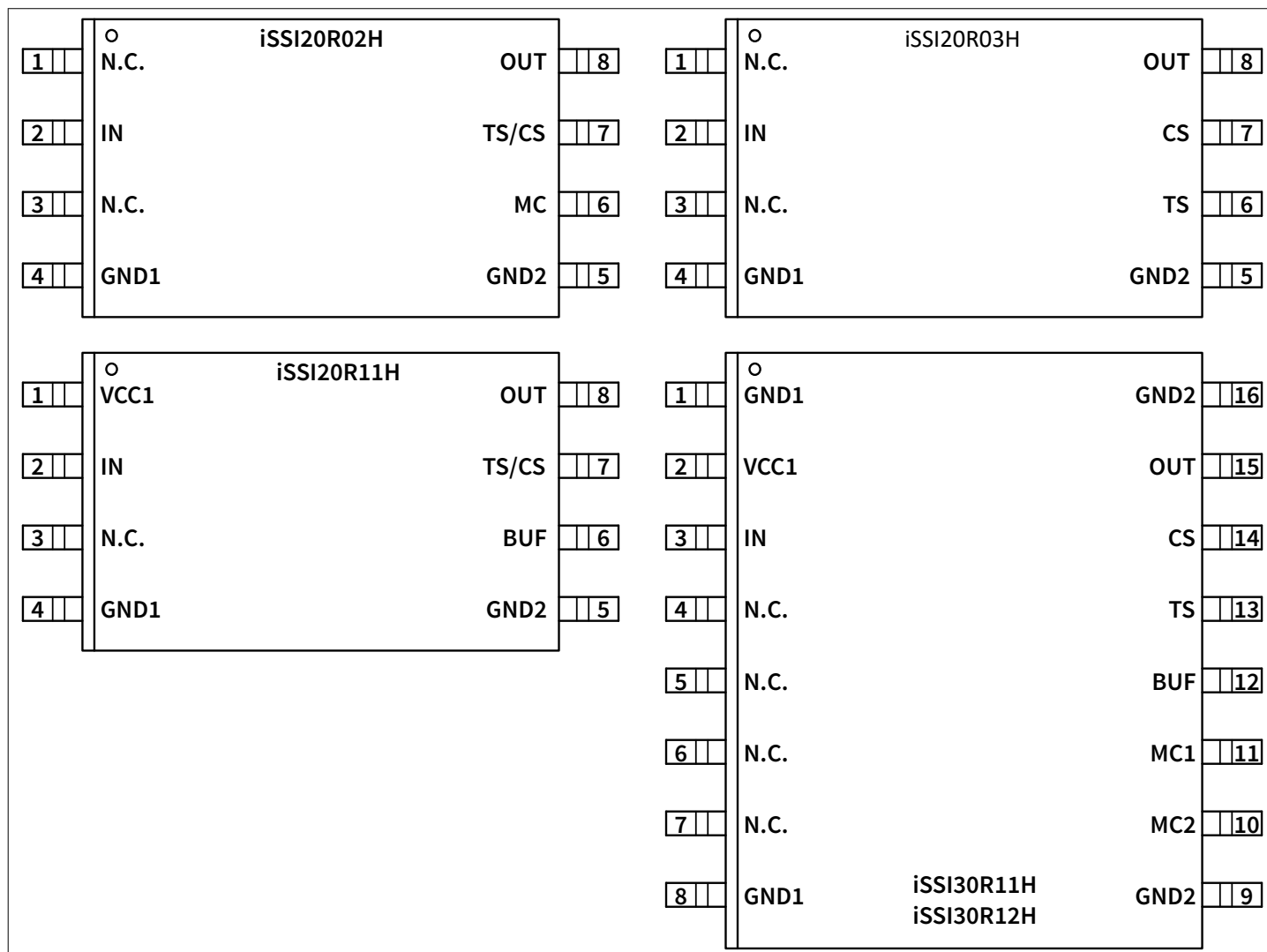


Figure 5 Block diagram of iSSI30R12H

## 2 Pin configuration

### 2.1 Pin configuration



**Figure 6** Pin configuration of Infineon SSI family

**Table 1** Pin configuration for iSSI20R02H

Pin no.	Pin name	Pin type	Function
1	N.C.	-	Not connected
2	IN	PWR	Supply and non-inverting control input
3	N.C.	-	Not connected
4	GND1	PWR	Reference of control side
5	GND2	PWR	Reference of output side
6	MC	I	Miller clamp input
7	TS/CS	I/O	Output for temperature sensor bias current and input for sensed signal
8	OUT	O	Gate drive output

2 Pin configuration

**Table 2 Pin configuration for iSSI20R03H**

Pin no.	Pin name	Pin type	Function
1	N.C.	-	Not connected
2	IN	PWR	Supply and non-inverting control input
3	N.C.	-	Not connected
4	GND1	PWR	Reference of control side
5	GND2	PWR	Reference of output side
6	TS	I/o	Output for temperature sensor bias current and input for temperature signal
7	CS	I	Input for current-sense signal
8	OUT	O	Gate drive output

**Table 3 Pin configuration for iSSI20R11H**

Pin no.	Pin name	Pin type	Function
1	VCC1	PWR	Supply input
2	IN	I	Non-inverting control input
3	N.C.	-	Not connected
4	GND1	PWR	Reference of control side
5	GND2	PWR	Reference of output side
6	BUF	I/O	Output for buffer charges and input for fast turn-on
7	TS/CS	I/O	Output for temperature sensor bias current and input for sensed signal
8	OUT	O	Gate drive output

**Table 4 Pin configuration for iSSI30R11H and iSSI30R12H**

Pin no.	Pin name	Pin type	Function
1	GND1	PWR	Reference of control side
2	VCC1	PWR	Supply input
3	IN	I	Non-inverting control input
4	N.C.	-	Not connected
5	N.C.	-	Not connected
6	N.C.	-	Not connected
7	N.C.	-	Not connected
8	GND1	PWR	Reference of control side
9	GND2	PWR	Reference of output side
10	MC2	I	Dynamic Miller clamp input 1
11	MC1	I	Dynamic Miller clamp input 2
12	BUF	I/O	Output for buffer charges and input for fast turn-on

**(table continues...)**

**Table 4** (continued) Pin configuration for iSSI30R11H and iSSI30R12H

Pin no.	Pin name	Pin type	Function
13	<i>TS</i>	I/O	Output for temperature sensor bias current and input for sensed signal
14	<i>CS</i>	I	Input for current sense signal
15	<i>OUT</i>	O	Gate drive output
16	<i>GND2</i>	PWR	Reference of output side

## 2.2 Pin description

- *VCC1*: Supply of input side; best operated with 3.3 V; can be shorted to terminal *IN*; referenced to *GND1*.
- *IN*: Logic input for variants iSSI20R11H, iSSI30R11H and iSSI30R12H, can be shorted to *VCC1*. It is the input supply pin for variants iSSI20R02H and iSSI20R03H. Pin is referenced to *GND1*
- *GND1*: Reference pin for *VCC1* and *IN*.
- *GND2*: Reference pin for *MC*, *MC1*, *MC2*, *CS*, *TS*, *TS/CS*, *OUT* and *BUF*.
- *MC*, *MC1*, *MC2*: Input pins for dynamic Miller clamp. Keep these pins unconnected for deactivating the dynamic Miller clamp. Referenced to *GND2*.
- *CS*: Current sense input. When unused, it is recommended to connect to *GND2*. Referenced to *GND2*.
- *TS*: Temperature sense input. When unused, it is recommended for variant iSSI30R12H to connect a capacitor in a range of 0.5 nF to 1.5 nF from *TS* to *GND2*; when unused for all other variants, it is recommended to connect to *GND2*. Referenced to *GND2*.
- *TS/CS*: Pin can be used either as temperature sense input or as current sense input. When unused, it is recommended to connect to *GND2*. Referenced to *GND2*.
- *OUT*: Gate drive output. Referenced to *GND2*.
- *BUF*: Gate drive buffer. Typically, a capacitor is connected to implement the fast turn-on feature. Referenced to *GND2*.

### 3 Electrical characteristics and parameters

#### 3.1 Absolute maximum ratings

**Table 5 Absolute maximum ratings**

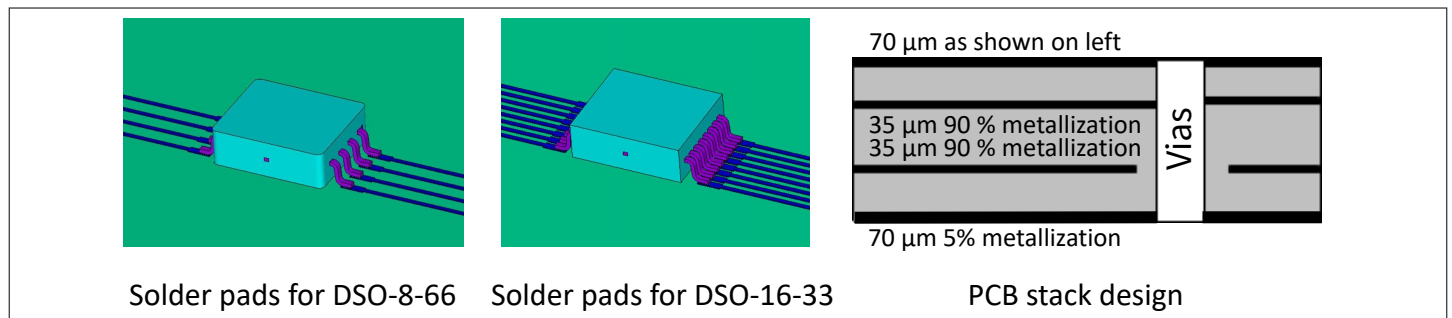
Parameter	Symbol	Values			Unit	Note or condition
		Min.	Typ.	Max.		
Input to output offset voltage	$V_{\text{OFFSET}}$	-1200	-	1200	V	$V_{\text{offset}} =  V_{\text{GND1}} - V_{\text{GND2}} $ <sup>1)</sup>
Input supply voltage	$V_{\text{IN}}$ $V_{\text{VCC1}}$	-10	-	4.25	V	iSSI20R02H, iSSI20R03H iSSI20R11H, iSSI30R11H, iSSI30R12H
Input logic voltage (terminal IN)	$V_{\text{IN,logic}}$	-10	-	15	V	Reference to GND1
Output voltage at terminal OUT	$V_{\text{OUT}}$	-0.3		20	V	<sup>2)</sup>
Voltage at terminal MC	$V_{\text{MC}}$	-0.3		3.6	V	<sup>2)</sup>
Voltage at terminals TS, CS or TS/CS (static)	$V_{\text{TS}}, V_{\text{CS}}$ $V_{\text{TS/CS}}$	-1.2		4	V	<sup>2)</sup>
Voltage at terminals CS, TS and TS/CS (positive signals, dynamic)	$V_{\text{pin,dyn}}$	0	-	6	V	<sup>2)</sup> $0 < I_{\text{pin,dyn}} < 10 \text{ mA}$ , $t_{\text{p}} < 2 \mu\text{s}$ , $d < 0.001$
Voltage at terminals CS, TS and TS/CS (negative signals, dynamic)	$V_{\text{pin,dyn}}$	-2	-	0	V	<sup>2)</sup> $0 > I_{\text{pin,dyn}} > -10 \text{ mA}$ , $t_{\text{p}} < 2 \mu\text{s}$ , $d < 0.001$
Voltage at terminal BUF	$V_{\text{BUF}}$	-0.3		20	V	<sup>2)</sup>
Input supply current	$I_{\text{IN}}$ $I_{\text{VCC1}}$	0	-	120	mA	iSSI20R02H, iSSI20R03H iSSI20R11H, iSSI30R11H, iSSI30R12H
Current at terminal OUT (static)	$I_{\text{OUT}}$	-10		10	mA	Output deactivated
Current at terminal OUT (dynamic)	$I_{\text{OUT,dyn}}$	-100	-	100	mA	Output deactivated; $t_{\text{p}} < 10 \mu\text{s}$ for negative current pulses; $t_{\text{p}} < 1 \mu\text{s}$ for positive current pulses
Current at terminal MC (static)	$I_{\text{MC}}$	-6		6	mA	<sup>2)</sup>
Current at terminal MC (dynamic)	$I_{\text{MC,dyn}}$	-100		100	mA	$t_{\text{p}} < 1 \mu\text{s}$ ; $d < 1\%$
Current at terminal TS	$I_{\text{TS}}$	-1		1	mA	<sup>2)</sup>
Current at terminal CS or TS/CS	$I_{\text{CS}}, I_{\text{TS/CS}}$	-1		1	mA	<sup>2)</sup>
Current at terminal BUF (static)	$I_{\text{BUF}}$	-10		10	mA	
Current at terminal BUF (dynamic)	$I_{\text{BUF,dyn}}$	-1		1	A	$t_{\text{p}} < 1 \mu\text{s}$
Power dissipation input part	$P_{\text{DIN}}$			200	mW	$T_{\text{A}} = 85^{\circ}\text{C}$ <sup>3) 4)</sup>
Power dissipation output part	$P_{\text{DOUT}}$			4.5	mW	$T_{\text{A}} = 85^{\circ}\text{C}$ <sup>5) 6)</sup>
Thermal resistance junction-to-ambient	$R_{\text{THJA}}$			140 96	K/W	$T_{\text{A}} = 85^{\circ}\text{C}$ , PG DSO-8-66, 2s2p footprint only $T_{\text{A}} = 85^{\circ}\text{C}$ , PG DSO-16-33, 2s2p footprint only

(table continues...)

**Table 5** (continued) Absolute maximum ratings

Parameter	Symbol	Values			Unit	Note or condition
		Min.	Typ.	Max.		
Characterization parameter junction-to-package top	$\Psi_{Jtop}$			39.77	K/W	$T_A = 85^\circ\text{C}$ , PG-DSO-8-66, 2s2p footprint only
				35.30		$T_A = 85^\circ\text{C}$ , PG-DSO-16-33, 2s2p footprint only
ESD robustness - human body model	$ V_{ESD,HBM} $	2			kV	7)
ESD robustness - charged device model	$ESD,CDM$	-	-	TC 1000	-	8)
Junction temperature	$T_J$	-40		150	$^\circ\text{C}$	
Storage temperature	$T_{ST}$	-55		150	$^\circ\text{C}$	
Maximum switching frequency	$f_{SW}$	-	-	2	kHz	$C_{Load} = 100\text{ pF}$ , $V_{IN} = 3.3\text{ V}$ , $V_{VCC1} = 3.3\text{ V}$ (where appropriate)

- 1) For functional operation only
- 2) Reference to GND2.
- 3) PG-DSO-8-66: derating of power above  $T_j = 122^\circ\text{C}$  with  $7.14\text{ mW}/^\circ\text{C}$ , layout 2s2p (JESD 51-5 / JESD 51-7).
- 4) PG-DSO-16-33: derating of power above  $T_j = 130.8^\circ\text{C}$  with  $10.42\text{ mW}/^\circ\text{C}$ , layout 2s2p (JESD 51-5 / JESD 51-7).
- 5) PG-DSO-8-66: derating of power above  $T_j = 149.3^\circ\text{C}$  with  $7.14\text{ mW}/^\circ\text{C}$ , layout 2s2p (JESD 51-5 / JESD 51-7).
- 6) PG-DSO-16-33: derating of power above  $T_j = 149.5^\circ\text{C}$  with  $10.42\text{ mW}/^\circ\text{C}$ , layout 2s2p (JESD 51-5 / JESD 51-7).
- 7) According to ANSI/ESDA/JEDEC-JS-001-2017 (discharging a 100 pF capacitor through a 1.5 k $\Omega$  series resistor).
- 8) According to ANSI/ESDA/JEDEC-JS-002-2014 (TC = highest test condition passed according to AEC-Q100-011 Rev D).



**Figure 7** Thermal reference design

## 3.2 Operating parameters

**Table 6** Operating parameters

Parameter	Symbol	Values			Unit	Note or condition
		Min.	Typ.	Max.		
Input supply voltage (terminal VCC1 (or IN if VCC1 is absent))	$V_{VCC1}$	2.85	3.3	3.5	V	-
Voltage at terminals TS, CS, or TS/CS (static)	$V_{TS}, V_{CS}$ $V_{TS/CS}$	-0.5		2.7	V	1)

(table continues...)

**Table 6** (continued) Operating parameters

Parameter	Symbol	Values			Unit	Note or condition
		Min.	Typ.	Max.		
External input supply capacitance including tolerances of the capacitor	$C_{VCC1,ext}$	-	-	4.7	nF	
External capacitance at terminal TS including tolerances of the capacitor (variant iSSI30R12H)	$C_{TS,ext}$	-	-	1.5	nF	Temperature sensor connected between terminals TS and GND2
Ambient temperature	$T_A$	-40	-	125	°C	-
Junction temperature	$T_J$	-40	-	125	°C	-
Common-mode transient immunity	$ dv_{CM}/dt $			200	V/ns	

1) Reference to GND2

### 3.3 Electrical characteristics

The minimum and maximum electrical characteristics include the spread of values over supply voltages and temperatures within the operating parameters. Electrical characteristics are tested in production at  $T_A = 25^\circ\text{C}$  and the default load at terminal OUT is 100 pF. Typical values represent the median values measured at supply voltage  $V_{IN} = 3.3\text{ V}$  (or  $V_{VCC1} = 3.3\text{ V}$  where applicable) and  $T_A = 25^\circ\text{C}$ . Minimum and maximum characteristics are verified by characterization/design. All voltages are referenced to their respective GND (GND1 for input side pins and GND2 for output side pins). This is valid for all electrical characteristics unless specified otherwise.

#### 3.3.1 IC Supply

**Table 7** IC Supply

Parameter	Symbol	Values			Unit	Note or condition
		Min.	Typ.	Max.		
UVLO threshold input side (power up)	$V_{UVLOH1}$	2.7	2.775	2.85	V	
UVLO threshold input side (power down)	$V_{UVLOL1}$	2.6	2.68	2.75	V	Reference to GND1
UVLO hysteresis input side	$V_{HYS1}$	89	-	-	mV	1) $V_{UVLOH1} - V_{UVLOL1}$
Supply current input side at terminal IN (or VCC1 where available)	$I_{IN}$	14	16	19	mA	$V_{IN} = 3.3\text{ V}, I_{OUT} = 0$
Standby input supply current at terminal VCC1	$I_{IN,STBY}$	-	1.4	2.5	mA	$V_{VCC1} = 3.3\text{ V}, V_{IN} = 0$
Integrated supply bias resistance	$R_{VCC1,bias}$	2.45		7.14	$\Omega$	
Reverse supply resistance	$R_{VCC1,rev}$ $R_{IN,rev}$	1 0.17	-	-	M $\Omega$	iSSI20R11H, iSSI30R11H and iSSI30R12H, $V_{test} = -2.5\text{ V}$ iSSI20R02H, iSSI20R03H, $V_{test} = -2.5\text{ V}$
Off-time before turn-on	$t_{OFF,IN}$ $t_{OFF,VCC1}$	25	-	-	$\mu\text{s}$	1) $V_{IN} < V_{UVLOL1}$ (or $V_{VCC1} < V_{UVLOL1}$ where applicable)

3 Electrical characteristics and parameters

1) Parameter is not subject to production test - verified by design/characterization.

### 3.3.2 Logic input (iSSI20R11H, iSSI30R11H, iSSI30R12H)

**Table 8** Logic input (iSSI20R11H, iSSI30R11H, iSSI30R12H)

Parameter	Symbol	Values			Unit	Note or condition
		Min.	Typ.	Max.		
IN logic low input threshold voltage	$V_{IL}$	1.0	1.2	-	V	Reference to GND1
IN logic high input threshold voltage	$V_{IH}$		2.1	2.3	V	
IN logic low/high hysteresis	$V_{IN,HYS}$	0.7			V	
IN logic pull down resistor	$R_{IN,PD}$	200	-	-	k $\Omega$	$V_{IN} = 2.5\text{ V}$
Off-time before turn-on	$t_{OFF,IN}$	25	-	-	$\mu\text{s}$	<sup>1)</sup> $V_{VCC1} = 3.3\text{ V}, V_{IN} < V_{IL,min}$

1) Parameter is not subject to production test - verified by design/characterization.

### 3.3.3 Gate drive

**Table 9** Gate drive

Parameter	Symbol	Values			Unit	Note or condition
		Min.	Typ.	Max.		
Output voltage	$V_{OUT}$	15.5	17.1	18.5	V	<sup>1)</sup> $V_{IN} = V_{VCC1} = 3.3\text{ V}, I_{OUT} = 0, T_J = 25^\circ\text{C}$
Output voltage	$V_{OUT}$	10	17.1	20	V	<sup>1)</sup> $V_{VCC1} = V_{IN} = 3.3\text{ V}, I_{OUT} = 0$
Output voltage	$V_{OUT}$	10	13	16	V	<sup>1)</sup> Supply at VCC1: $V_{VCC1} = 2.6\text{ V}, V_{IN} = 3.3\text{ V}, I_{OUT} = 0$ Supply at IN: $V_{IN} = 2.6\text{ V}$
Short circuit output current (iSSI20R02H, iSSI20R03H)	$I_{OUT}$	100	175	-	$\mu\text{A}$	$V_{IN} = 3.3\text{ V}, V_{OUT} = 0$
Short circuit output current (iSSI20R11H, iSSI30R11H, iSSI30R12H)	$I_{OUT}$	150	325	550	$\mu\text{A}$	$V_{IN} = 3.3\text{ V}, V_{OUT} = 0$
Turn-off current	$I_{off,sat}$	50	160	270	mA	<sup>2)</sup> $V_{IN} = 0\text{ V}, V_{OUT} = 5\text{ V}$
Fast turn-off transistor saturation current	$I_{off,fast,sat}$	488	-	-	mA	<sup>2)</sup> $V_{IN} = 3.3\text{ V}, V_{CS} = 0.3\text{ V}, V_{OUT} = 5\text{ V}$
High-level output resistance	$R_{OH}$	60	110	155	k $\Omega$	$V_{IN} = 3.3\text{ V}, \Delta V_{OUT} = 1\text{ V},$ iSSI20R02H, iSSI20R03H
High-level output resistance	$R_{OH}$	48	95	135	k $\Omega$	$V_{IN} = 3.3\text{ V}, \Delta V_{OUT} = 1\text{ V},$ iSSI20R11H, iSSI30R11H, iSSI30R12H
Low-level output resistance	$R_{OL}$	5	8.5	12	$\Omega$	$V_{VCC1} = 0, V_{OUT} < 0.5\text{ V}$

(table continues...)

**Table 9** (continued) Gate drive

Parameter	Symbol	Values			Unit	Note or condition
		Min.	Typ.	Max.		
Turn-on propagation delay terminal IN and VCC1 (where applicable) to terminal OUT or BUF (where applicable)	$t_{PDON}$	-	-	20	$\mu\text{s}$	$V_{IN} = 3.3\text{ V}$ , $V_{VCC1} = 3.3\text{ V}$ (where applicable), no load
Turn-off propagation delay	$t_{PD OFF}$	0.3	3	6	$\mu\text{s}$	$V_{IN} = 0$ , no load, $V_{VCC1} = 3.3\text{ V}$ (where applicable)
Rise time	$t_r$ , $t_{r, BUF}$	-	8	15	$\mu\text{s}$	$V_{VCC1} = 3.3\text{ V}$ (where appropriate), $V_{IN} = 3.3\text{ V}$ , no load
Fall time	$t_f$	-	1.9	4	$\mu\text{s}$	Supply at VCC1: $V_{VCC1} = 3.3\text{ V}$ , $V_{IN} \leq 1\text{ V}$ , $C_{BUF} = 3\text{ nF}$ , no load Supply at IN: $V_{IN} \leq 2.6\text{ V}$
Fall time	$t_f$	1	3.2	6.5	$\mu\text{s}$	Supply at VCC1: $V_{VCC1} = 3.3\text{ V}$ , $V_{IN} \leq 1\text{ V}$ , $C_L = 10\text{ nF}$ Supply at IN: $V_{IN} \leq 2.6\text{ V}$ , $C_L = 10\text{ nF}$

1) Reference to GND2.

2) Parameter is not subject to production test - verified by design/characterization.

### 3.3.4 Fast turn-on (iSSI20R11H, iSSI30R11H, iSSI30R12H)

**Table 10** Fast turn-on (iSSI20R11H, iSSI30R11H, iSSI30R12H)

Parameter	Symbol	Values			Unit	Note or condition
		Min.	Typ.	Max.		
Fast turn-on threshold (power up)	$V_{BUF, th}$	10.0	10.4	10.8	V	1)
Fast turn-on saturation current	$I_{on, fast, sat}$	232	400	-	mA	2) $V_{OUT} = 5\text{ V}$ , $V_{BUF} = 10.4\text{ V}$
Resistance between terminal BUF and OUT after fast turn-on	$R_{BUF-OUT}$	300	500	-	k $\Omega$	2)
Fast turn-on propagation delay input-to-output	$t_{PDON, fast}$	-	5	-	ms	2) $C_{BUF} = 33\text{ nF}$ , $C_{OUT} = 5.6\text{ nF}$ , $V_{OUT} = 1\text{ V}$
Fast turn-on rise time	$t_{r, fast}$	-	530	1000	ns	2) $C_{BUF} = 48\text{ nF}$ , $C_{OUT} = 10\text{ nF}$

1) Reference to GND2.

2) Parameter is not subject to production test - verified by design/characterization.

### 3.3.5 Dynamic Miller clamping

**Table 11** Dynamic Miller clamping

Parameter	Symbol	Values			Unit	Note or condition
		Min.	Typ.	Max.		
Dynamic Miller clamp saturation current	$I_{CLAMP}$	500	1700	-	mA	<sup>1)</sup> $V_{MC} = 2.5\text{ V}; V_{OUT} = 3\text{ V}$
Low-level output resistance during dynamic Miller clamping	$R_{OL,MC}$	0.7	1.5	3.5	$\Omega$	$V_{MC} = 2.5\text{ V}, I_{OUT} = 10\text{ mA}$
Input resistance terminal MC	$R_{MC}$	400	500	600	$\Omega$	$V_{VCC1} = 0, V_{MC} = 0.5\text{ V}$

<sup>1)</sup> Parameter is not subject to production test - verified by design/characterization.

### 3.3.6 Over-temperature protection

**Table 12** Over-temperature protection

Parameter	Symbol	Values			Unit	Note or condition
		Min.	Typ.	Max.		
Temperature sense comparator threshold (iSSI30R12H)	$V_{TS,th1}$	1.056	1.095	1.120	V	<sup>1)</sup> $V_{IN} = 3.3\text{ V}$
Temperature sense comparator threshold (other variants)	$V_{TS,th2}$	190	200	210	mV	<sup>1)</sup> $V_{IN} = 3.3\text{ V}$
Temperature sense bias current (terminals TS and TS/CS)	$I_{TS,bias}$ $I_{TS/CS,bias}$	40	50	60	$\mu\text{A}$	$V_{IN} = V_{VCC1} = 3.3\text{ V}$
Temperature sense protection propagation delay	$t_{PD,TS}$	-	-	5	$\mu\text{s}$	$V_{IN} = 3.3\text{ V}, C_{OUT} \leq 100\text{ pF}, V_{TS} = V_{TS,th1} - 20\text{ mV}$ (iSSI30R12H), $V_{TS} = V_{TS,th2} + 20\text{ mV}$ (other variants)
Temperature sense filter time	$t_{TS,filter}$	1.9 0.12	2.7 0.15	3.5 0.175	$\mu\text{s}$	<sup>2)</sup> $V_{VCC1} = 3.3\text{ V}, V_{TS} = V_{TS,th1} - 20\text{ mV}$ (iSSI30R12H), $V_{VCC1} = 3.3\text{ V}, V_{TS} = V_{TS,th2} + 20\text{ mV}$ (other variants)
Fast turn-off fall time after OTP trigger	$t_{f,TS}$	-	-	725	ns	<sup>2)</sup> $C_{OUT} = 28\text{ nF}, V_{OUT} = 12\text{ V}$

<sup>1)</sup> Reference to GND2.

<sup>2)</sup> Parameter is not subject to production test - verified by design/characterization.

### 3.3.7 Overcurrent protection

**Table 13** Overcurrent protection

Parameter	Symbol	Values			Unit	Note or condition
		Min.	Typ.	Max.		
Overcurrent comparator shut down threshold	$ V_{CS,th} $	185	200	215	mV	<sup>1)</sup> $V_{VCC1} = 3.3\text{ V}$ ; Output is active;
Overcurrent shut-down delay	$t_{CS,off}$	-	0.6	1	$\mu\text{s}$	$V_{CS} = 300\text{ mV}$ , $V_{OUT} = 2.5\text{ V}$
Overcurrent filter time	$t_{CS,filter}$	120	150	175	ns	<sup>2)</sup> $ V_{CS}  = 0.3\text{ V}$
Fast turn-off fall time after OCP trigger	$t_{f,CS}$	-	-	725	ns	<sup>2)</sup> $C_{OUT} = 28\text{ nF}$ , $V_{OUT} = 12\text{ V}$ , $ dv_{CS}/dt  > 480\text{ mV}/\mu\text{s}$

1) Reference to GND2.

2) Parameter is not subject to production test - verified by design/characterization.

## 4 Insulation and safety-related specification

### 4.1 Safety-limiting values

Note: safety-limiting values define the operating conditions under which the isolation barrier can be guaranteed to stay unaffected. This corresponds with the maximum allowed junction temperature, as temperature-induced failures might cause significant overheating and eventually damage the isolation barrier.

Parameter	Symbol	Value	Unit	Note or condition
<b>iSSI20R02H, iSSI20R03H, iSSI20R11H</b>				
Maximum ambient safety temperature	$T_S$	150	°C	
Safety input power dissipation	$P_S$	200	mW	Derating required above $T_A = 122^\circ\text{C}$ with $7.14 \text{ mW}/^\circ\text{C}$ , $T_J = 150^\circ\text{C}$
Safety input supply current	$I_{SI}$	50	mA	Derating required above $T_A = 122^\circ\text{C}$ with $1.8 \text{ mA}/^\circ\text{C}$ , $T_J = 150^\circ\text{C}$
Safety output power dissipation	$P_{SO}$	4.5	mW	Derating required above $T_A = 149.4^\circ\text{C}$ with $7.14 \text{ mW}/^\circ\text{C}$ , $T_J = 150^\circ\text{C}$

### **iSSI30R11H, iSSI30R12H**

Maximum ambient safety temperature	$T_S$	150	°C	
Safety input power dissipation	$P_{SI}$	200	mW	Derating required above $T_A = 130.8^\circ\text{C}$ with $10.42 \text{ mW}/^\circ\text{C}$ , $T_J = 150^\circ\text{C}$
Safety input supply current	$I_{SI}$	50	mA	Derating required above $T_A = 130.8^\circ\text{C}$ with $2.6 \text{ mA}/^\circ\text{C}$ , $T_J = 150^\circ\text{C}$
Safety output power dissipation	$P_{SO}$	4.5	mW	Derating required above $T_A = 149.5^\circ\text{C}$ with $10.42 \text{ mW}/^\circ\text{C}$ , $T_J = 150^\circ\text{C}$

### 4.2 Reinforced insulation according to IEC 60747-17 (planned)

Parameter	Symbol	Value	Unit	Note or condition
External clearance	$CLR$	>8	mm	Shortest distance in air from any input pin to any output pin according to IEC 60664-1 <sup>1)</sup>
External creepage	$CRP$	>8	mm	Shortest distance over package surface from any input pin to any output pin according to IEC 60664-1 <sup>1)</sup>
Comparative tracking index	$CTI$	>400	V	According to IEC 60112
Material group		II		According to IEC 60112
Pollution degree		2		According to IEC 60664-1
Overvoltage category (According to IEC 60664-1)		I - IV I - IV I - III I-II		Rated mains voltage $\leq 150 \text{ V (rms)}$ Rated mains voltage $\leq 300 \text{ V (rms)}$ Rated mains voltage $\leq 600 \text{ V (rms)}$ Rated mains voltage $\leq 1000 \text{ V (rms)}$
Climatic category		40/125/ 21		

4 Insulation and safety-related specification

Parameter	Symbol	Value	Unit	Note or condition
<b>Input-to-output isolation according to UL1577 Ed. 5</b>				
Input-to-output isolation voltage	$V_{ISO}$	5700	$V_{rms}$	$V_{TEST} = V_{ISO}$ for $t = 60$ s (qualification); $V_{TEST} = 1.2 \times V_{ISO}$ for $t = 1$ s (100% productive tests)
<b>Input-to-output isolation according to IEC 60747-17 (planned)</b>				
Maximum rated transient isolation voltage	$V_{IOTM}$	8000	$V_{pk}$	$V_{TEST} = V_{IOTM}$ for $t_{ini} = 60$ s (type test and sample test) $V_{TEST} = 1.2 \times V_{IOTM}$ for $t_{ini} = 1$ s (routine test)
Maximum rated repetitive peak isolation voltage	$V_{IORM}$	1200	$V_{pk}$	According to Time Dependent Dielectric Breakdown (TDDB) test
Apparent charge	$q_{PD}$	<5	pC	Method (b1) (routine test and type test pre-conditioning) $V_{PD(ini),b} = 1.2 \times V_{IOTM}$ for $t_{ini} = 1$ s $V_{PD(m)} = 1.875 \times V_{IORM}$ for $t_m = 1$ s  Method (a) (type test, subgroup 1 final measurements) $V_{PD(ini),a} = V_{IOTM}$ for $t_{ini} = 60$ s $V_{PD(m)} = 1.6 \times V_{IORM}$ for $t_m = 10$ s <sup>3)</sup>
Impulse voltage	$V_{IMP}$	8000	$V_{pk}$	
Maximum surge isolation voltage	$V_{IOSM}$	11000	$V_{pk}$	$V_{TEST} \geq 1.3 \times V_{IMP}$ (type test) <sup>4)</sup>
Isolation resistance	$R_{IO}$	$>10^{12}$	$\Omega$	$V_{IO} = 500 V_{dc}$ for $t = 60$ s, $T_A = 25$ °C <sup>5)</sup>
Isolation resistance	$R_{IO}$	$>10^{11}$	$\Omega$	$V_{IO} = 500 V_{dc}$ for $t = 60$ s, $T_A = 125$ °C <sup>5)</sup>
Isolation resistance	$R_{IO\_S}$	$>10^9$	$\Omega$	$V_{IO} = 500 V_{dc}$ for $t = 60$ s, $T_S = T_A = 150$ °C <sup>5)</sup>
Isolation capacitance	$C_{IO}$	1.9	pF	$f = 1$ MHz <sup>5)</sup>

1) Creepage and clearance requirements depend on the application and related end-equipment isolation standard. Care should be taken to keep the required creepage and clearance value on printed-circuit-board level.

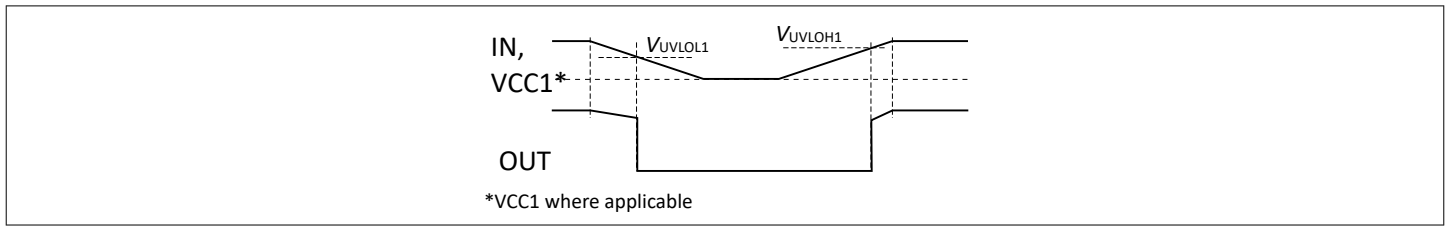
2) Safety certification pending.

3) The partial discharge voltage  $V_{PD(m)}$  applied during productive tests is greater (tbd  $V_{pk} > 1.875 \times V_{IORM}$ ) to include the  $F_4$  factor (1.1) required by end-equipment standards IEC 60664-1, IEC 62368-1, IEC 60950 ( $V_{PD(m)} = F_1 \times F_2 \times F_3 \times F_4 \times V_{IORM} = 1.875 \times F_4 \times V_{IORM}$ ). The  $F_3$  factor (1.25) is also considered for further stress of the insulation.

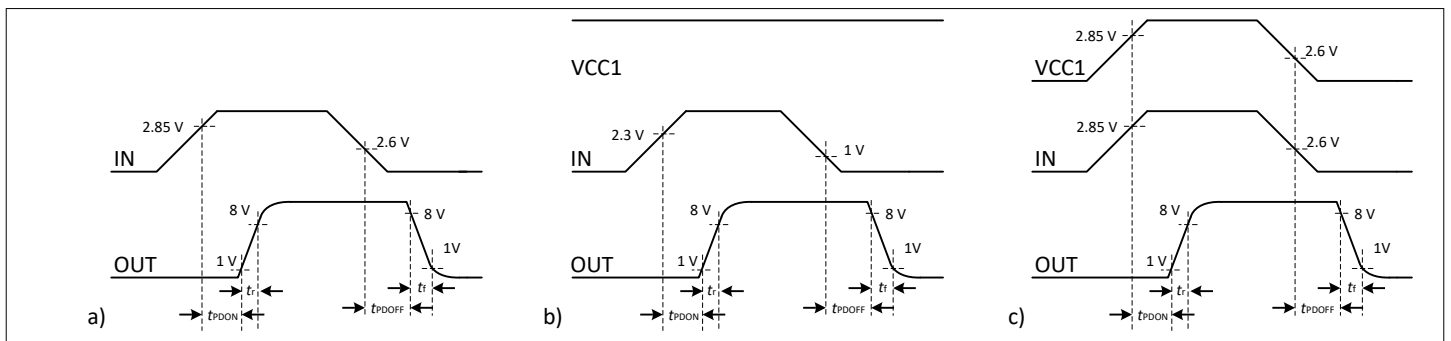
4) The surge test is performed in insulation oil to determine the intrinsic surge immunity of the insulation barrier.

5) The parameters apply to the product converted in a two terminals device with all terminals on side 1 connected together and all terminals on side 2 connected together.

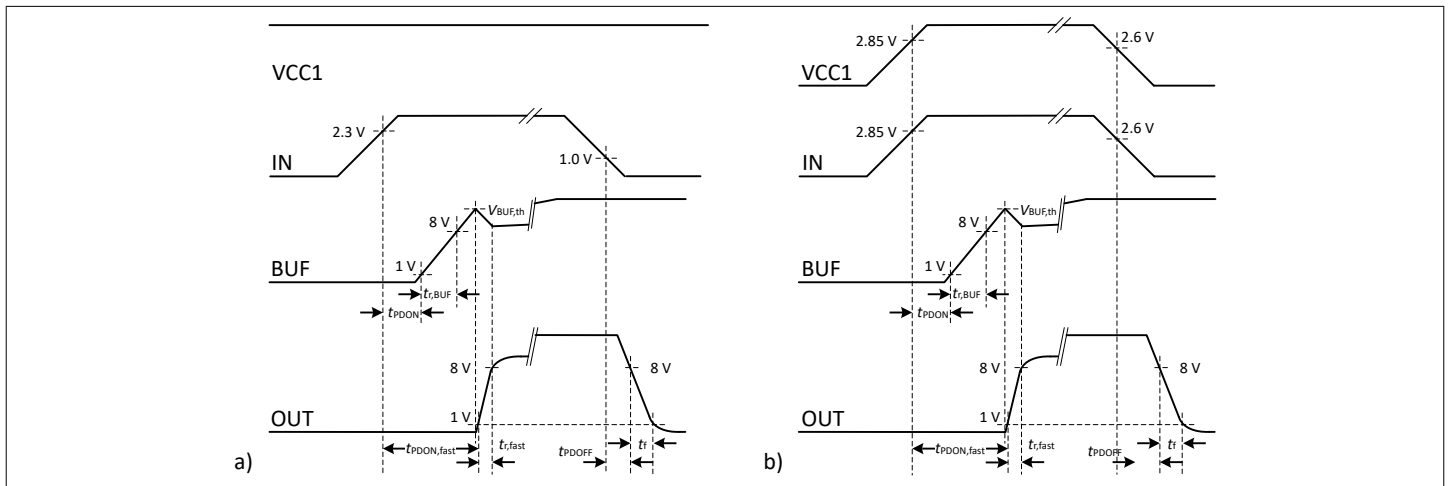
## 5 Timing diagrams



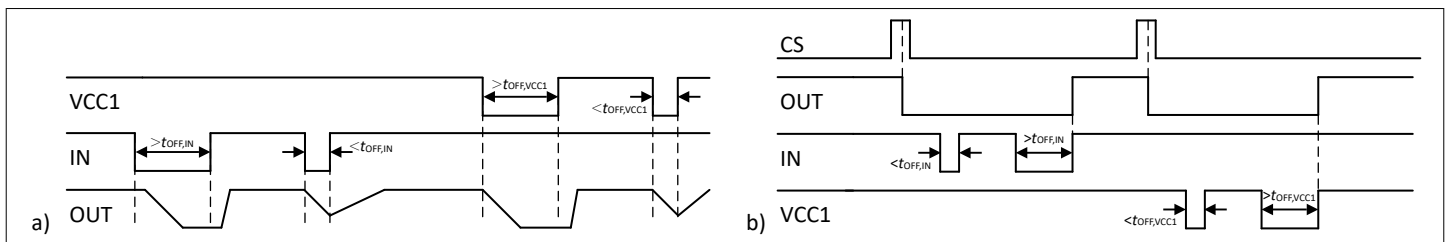
**Figure 8 UVLO behavior**



**Figure 9 Direct gate drive turn-on and turn-off propagation delay, rise and fall time: a) direct drive turn-on for variants iSSI20R02H and iSSI20R03H, b) separate VCC1 and IN using no buffer capacitor, c) VCC1 and IN shorted using no buffer capacitor**

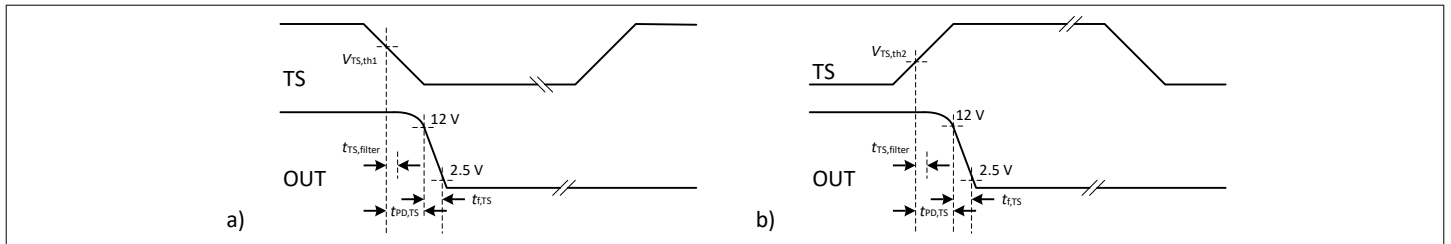


**Figure 10 Fast turn-on timing using a buffer capacitor: a) separate VCC1 and IN, b) VCC1 and IN shorted**

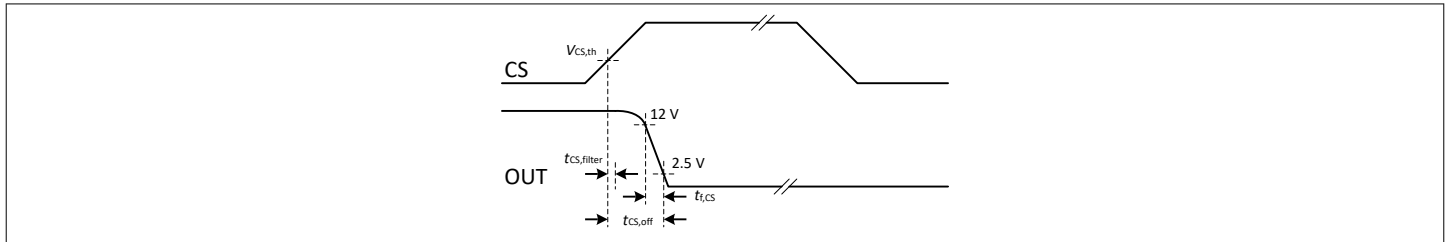


**Figure 11 a) Off-time before turn-on, b) off-time after protection (example of overcurrent protection)**

5 Timing diagrams



**Figure 12** Over-temperature protection timing: a) iSSI30R12H, b) others



**Figure 13** Overcurrent protection timing

## 6 Functional description

### 6.1 Input side

#### 6.1.1 Input side supply

The input side of the Infineon SSI family is 3.3 V compatible and operates best with an input voltage tolerance of 5%. The power-up under-voltage threshold voltage is  $V_{UVLOH1}$ . It ensures sufficient output voltage for operating the output. The power-down under-voltage threshold is  $V_{UVLOL1}$ . The integrated supply is based on a shunt regulator that emulates a diode structure to simplify designs. The device can then be supplied even by any voltage rail that exceeds the operating range by using a current limiting resistor placed in series to the supply terminal *IN* or *VCC1* (where applicable). If no suitable resistor in series to terminal *VCC1* is used for current limitation, then staying within the operating parameters is recommended to avoid unnecessary power dissipation in the IC.

The input side of the IC contains an integrated power supply buffer capacitor. External buffer capacitors for the supply voltage are not necessary, but possible. Such external buffer capacitors should not exceed  $C_{VCC1,ext}$ .

In addition, the Infineon SSI family provides a strong reverse bias capability for the supply terminals *IN* or *VCC1* (where applicable). This enables all variants to operate in differential operation with respect to their terminals *IN* and *GND1*.

A minimum off-time  $t_{OFF,IN}$  or  $t_{OFF,VCC1}$  is required between the turn-off and turn-on signals to establish a defined "off"-state on the output side of the isolator.

Variants iSSI20R02H and iSSI20R03H use the supply terminal *IN* to perform the reset procedure after the output side latch-off procedure of the protection functions. Variants iSSI20R11H, iSSI30R11H, and iSSI30R12H can perform this reset at either at terminal *VCC1* or at terminal *IN*. In any case of reset of any variant, ensure that the reset time is larger than  $t_{OFF,IN}$  or  $t_{OFF,VCC1}$  before turning on again after a protection event.

#### 6.1.2 Logic input

Variants iSSI20R11H, iSSI30R11H, and iSSI30R12H offer separate supply and control terminals. The control logic thresholds  $V_{IL}$  and  $V_{IH}$  at terminal *IN* are 3.3 V CMOS compliant and can be controlled directly from standard CMOS logic outputs. Please note that the signal level at terminal *IN* can be substantially higher than the supply voltage at terminal *VCC1*. For example, it is possible to apply signals on 5 V level while  $V_{VCC1} = 3.3$  V. The output acts in phase with the input control signal at terminal *IN*. Before turning on, a minimum off-time  $t_{OFF,IN}$  has to be considered for resetting the output side. If the equivalent MOSFET's input capacitance is larger than 100 pF longer off-times than  $t_{OFF,IN}$  might be needed.

A new reset procedure has to be performed after a protection triggered turn-off. Variants iSSI20R11H, iSSI30R11H, and iSSI30R12H can perform this reset at either at terminal *VCC1* or at terminal *IN*. In any case of reset of any variant, ensure that the reset time is larger than  $t_{OFF,IN}$  before turning on again after a protection event.

Applications using the variants iSSI20R11H, iSSI30R11H, and iSSI30R12H can use these isolators with externally shorted terminals *VCC1* and *IN*. In this case, all operating guidelines of variants iSSI20R02H and iSSI20R03H apply.

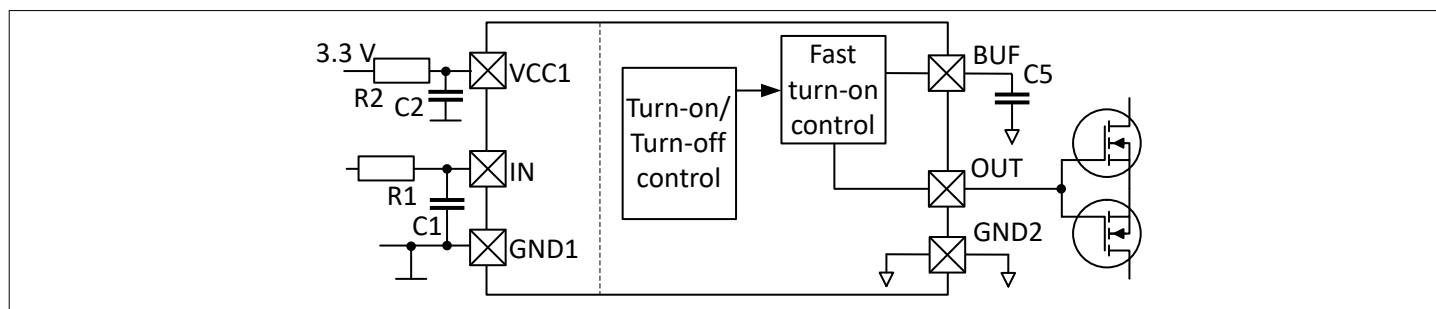
### 6.2 Output side

#### 6.2.1 Direct gate drive

Terminal *OUT* is the gate drive output. The output voltage  $V_{OUT}$  is sufficient to drive CoolMOS™, OptiMOS™, or TRENCHSTOP™ IGBT without additional, external buffers. Variants iSSI20R02 and iSSI20R03 provide the short circuit output current  $I_{OUT}$  directly to the gate. This enables a quick turn-on of MOS-controlled power transistor.

### 6.2.2 Fast turn-on feature

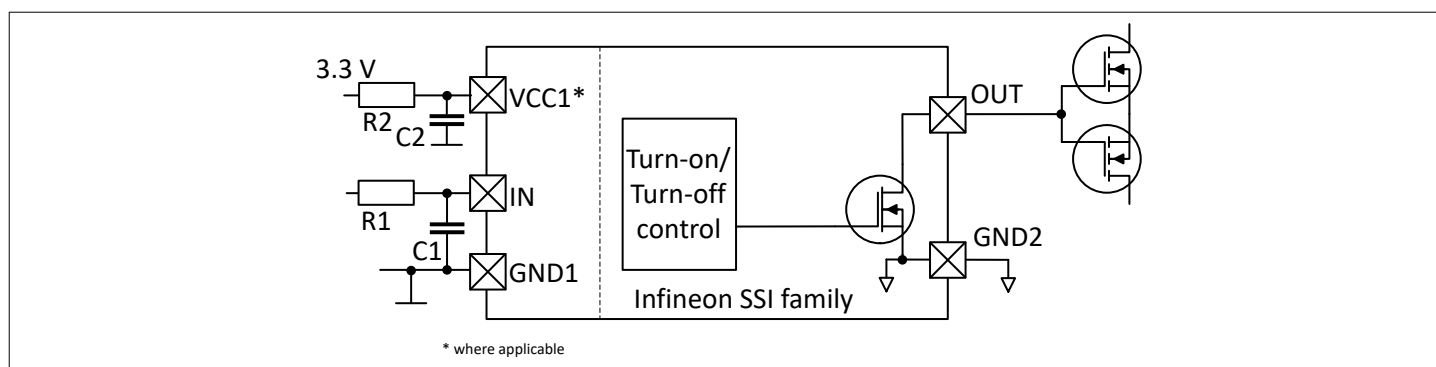
Variants iSSI20R11H, iSSI30R11H, and iSSI30R12H are designed for fast turn-on that further enforces the turn-on current by accumulating charge in an external buffer capacitor at terminal *BUF*. The accumulated charge is released to terminal *OUT*, if the voltage at terminal *BUF* equal or higher than the buffer threshold voltage  $V_{BUF,th}$  and a turn-on condition is given on the control side.



**Figure 14** Fast turn-on feature of iSSI20R11H, iSSI30R11H, and iSSI30R12H

### 6.2.3 Normal turn-off

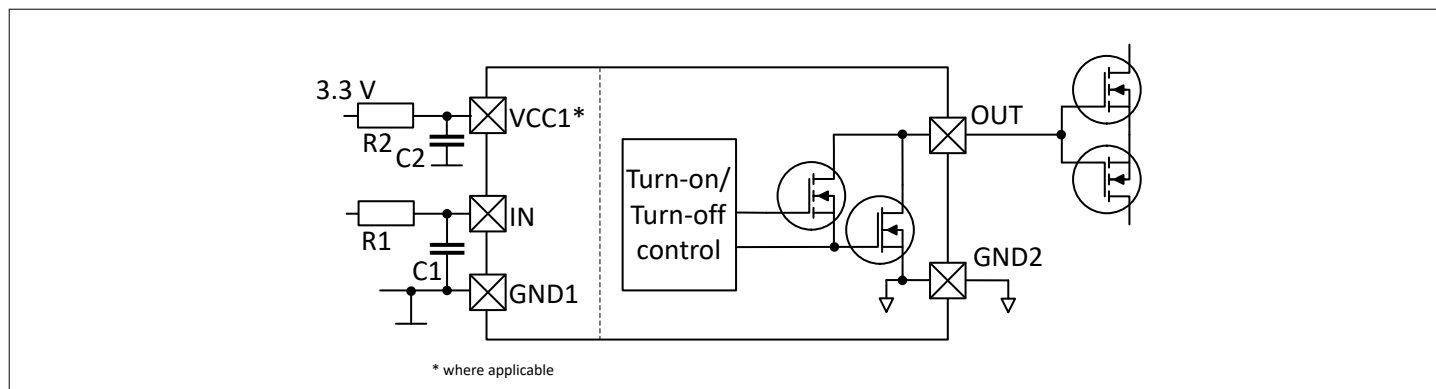
The normal turn-off feature is implemented in all variants. A turn-off signal from the input side activates the integrated depletion FET. The depletion FET discharges the gate node of the operated power transistor. The Infineon SSI family's sink saturation current  $I_{off,sat}$  is dimensioned to discharge CoolMOS™ S7 transistors within a few microseconds.



**Figure 15** Normal turn-off

### 6.2.4 Fast turn-off

Overcurrent or over-temperature events trigger the fast turn-off feature of the Infineon SSI family. The fast turn-off enables the Infineon SSI family to shut down the power transistors inside their safe operating area particularly under high load operations. The Infineon SSI family's fast turn-off sink saturation current  $I_{off,fast,sat}$  is dimensioned to discharge CoolMOS™ S7 transistors faster than a normal turn-off.



**Figure 16** Fast turn-off

### 6.2.5 Dynamic Miller clamping (DMC)

The  $dv/dt$  applied by the connected AC voltage creates capacitive displacement currents through the parasitic capacitances of a power transistor. This can lead to parasitic turn-on of the power switch by increasing the voltage at the gate node of the power switch during its "off"-state. Three major effects can cause  $dv/dt$  to occur in installations:

- surge voltages
- fast electric transients (burst)
- $dv/dt$  of line voltage

The  $dv/dt$  of line voltage results in a relatively slow  $dv/dt$  of  $320\text{ V} \cdot 2\pi \cdot 50\text{ Hz} \sim 100\text{ V/ms}$  in 230 V a.c. grids. Many power transistors are robust, by default, against parasitic turn-on under this condition. Surge voltages and fast electric transients result in a much faster  $dv/dt$  and power transistors benefit from the dynamic Miller clamping feature.

The dynamic Miller clamping feature ensures that the power switch stays in the "off" state. It is activated by connecting the power switch's drain to terminal *MC*, *MC1*, or *MC2* respectively with a suitable capacitor. The  $dv/dt$  appearing at the drain also injects a current into the related terminals *MCx* and activates of the dynamic Miller clamp FET.

Voltage clamping elements at the Miller clamping terminals may be needed to stay within the absolute maximum ratings.

### 6.2.6 Overcurrent protection

Overcurrent protection detects excessive, positive and negative current through the power transistor and uses the voltage drop at an external shunt resistor to trigger a comparator with a fixed threshold  $|V_{CS,th}|$  at terminal *CS* or *TS/CS*. Please note that  $V_{CS,th}$  can be positive or negative. Once triggered, the protection reacts quickly and is able to turn off, for example, CoolMOS™ IPT60R022S7 in very short time. Thus, it is able to support the AC-15 system tests according to IEC 60947-5-1 under appropriate operating conditions. The integrated noise filter has a filter time of  $t_{CS,filter}$  and can be backed up by an external RC-filter. However, it is recommended to have as little external filtering as possible to get a quick reaction time in case of overcurrent.

The triggering of the overcurrent protection leads to the latched turn-off of the power switch with a sinking current of  $I_{off, fast,sat}$ .

Terminal *TS/CS* sources a bias current for temperature sensing in iSSI20R02H and iSSI20R11H. As the current sensing shunt is usually very low-resistive, the effect of the biasing current  $I_{TS/CS,bias}$  with respect to the shunt signal can be neglected.

The dimensioning of the shunt follows this equation:  $R_{sh} = \frac{|V_{CS,th}|}{I_{pk,max}}$

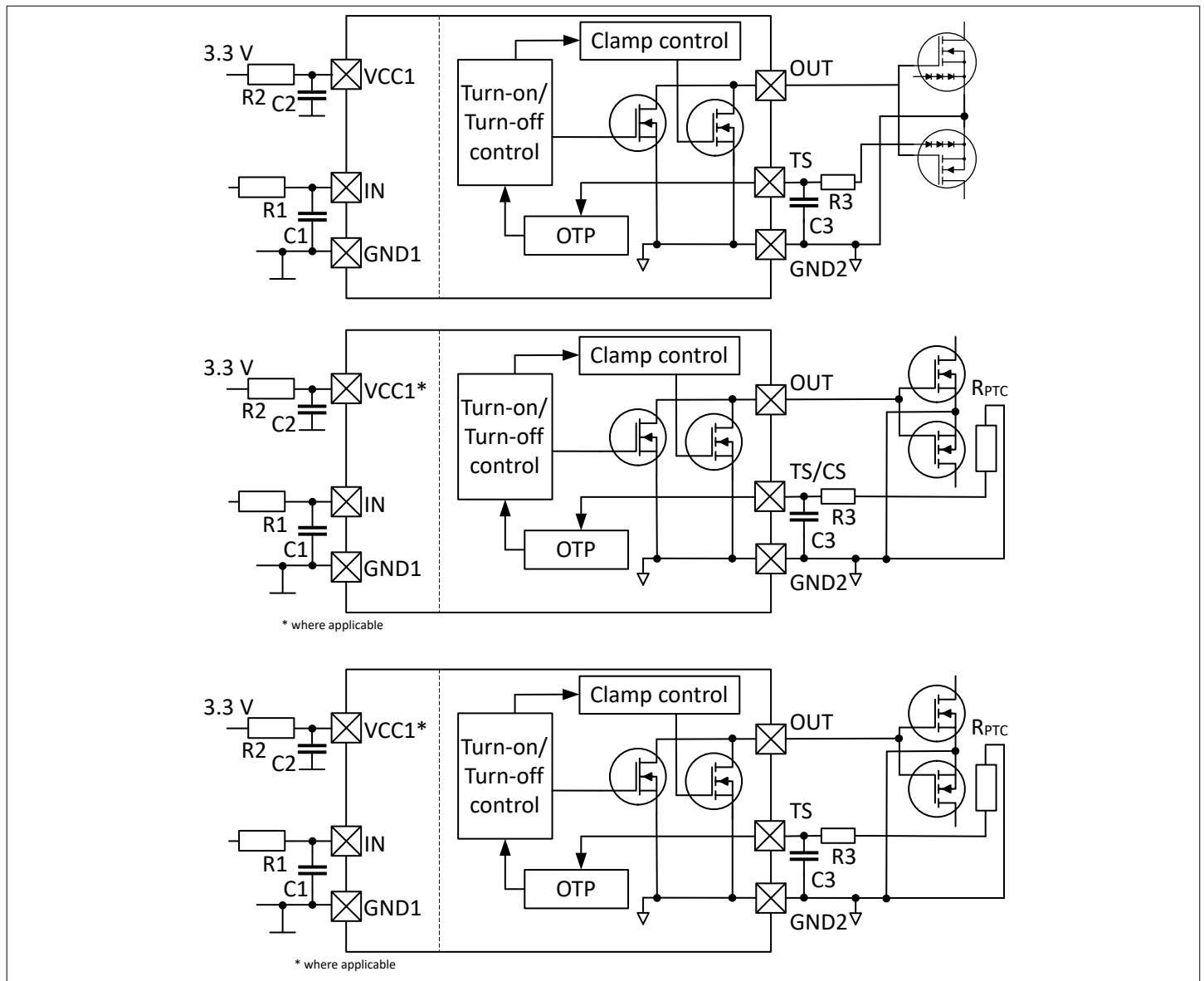
### 6.2.7 Over-temperature protection

The over-temperature protection of the Infineon SSI family offers two options to protect against excessive temperatures of the driven power transistor:

- Protection by reading a PTC resistor (iSSI20R02H, iSSI20R03H, iSSI20R11H, and iSSI30R11H)
- Protection by reading the threshold voltage of one or several diodes in series (iSSI30R12H, best matching with CoolMOS™ S7 with temperature sense)

The Infineon SSI family products provide a constant bias current  $I_{TS,bias}$  or  $I_{TS/CS,bias}$ , respectively, for the two types of temperature sensors listed above. The constant current generates a temperature dependent voltage at the temperature sensor. The sensor voltage is connected to terminal *TS* or *TS/CS*, and the terminal voltage is compared to the threshold  $V_{TS,th1}$  (iSSI30R12H) or  $V_{TS,th2}$  (other variants). The integrated comparator includes a noise filter of duration  $t_{TS,filter}$  for safe detection of the sensor signal that can be complemented by an external RC-filter. The capacitive portion of the external filter must be below the maximum value of  $C_{TS,ext}$  in combination with iSSI30R12H. The resistive portion of the filter influences the trigger temperature of the sensor, because the resistor adds a positive offset voltage to the temperature dependent voltage of the sensor. This influence can also be used to actively tune the protection feature for individual requirements. When using the over-temperature protection together with the over-current protection for example with iSSI30R11H, both sensing signals need to reference to GND2.

The triggering of the over-temperature protection leads to the latched turn-off of the power switch with a sinking current of  $I_{off, fast,sat}$ .



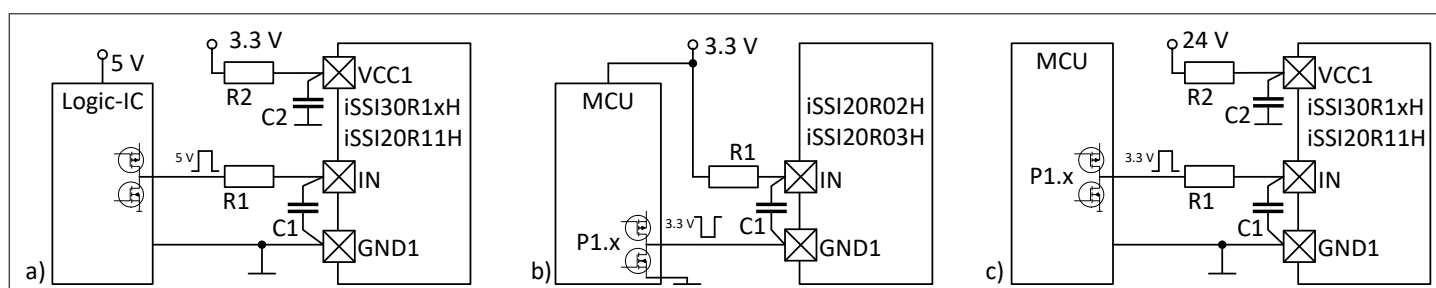
**Figure 17** Schematic examples of the over-temperature protection circuit for variant iSSI30R12H (top), variants iSSI20R02H and iSSI20R11H (middle), and variants iSSI20R03H and iSSI30R11H (bottom)

## 7 Application information

Infineon is providing this information as a courtesy only and without acknowledging any legal obligation. Information in the following application chapters is not part of the Infineon component specification, and Infineon does not warrant its accuracy or completeness. Infineon's customers are responsible for determining suitability of components for their purposes. Customers should validate and test their design implementation to confirm system functionality.

### 7.1 Adaptation of the supply voltage

The Infineon SSI-family is best operated from a voltage source of 3.3 V. This allows a direct supply from a microcontroller. Please note that normally the pull-down device of general purpose I/O-terminals or high current terminals is stronger than the pull-up device. Thus, it is better to use the pull-down device to control the voltage supply of the Infineon SSI as it is displayed in the figure below.



**Figure 18** Examples of application relevant control options

The left part in the figure shows the option of using a logic -IC that is supplied with 5 V. Therefore, the logic-IC provides a control signal with 5 V, too, while Infineon SSI is supplied with 3.3 V. This simplifies the interfacing as no downward-level-shifters are required.

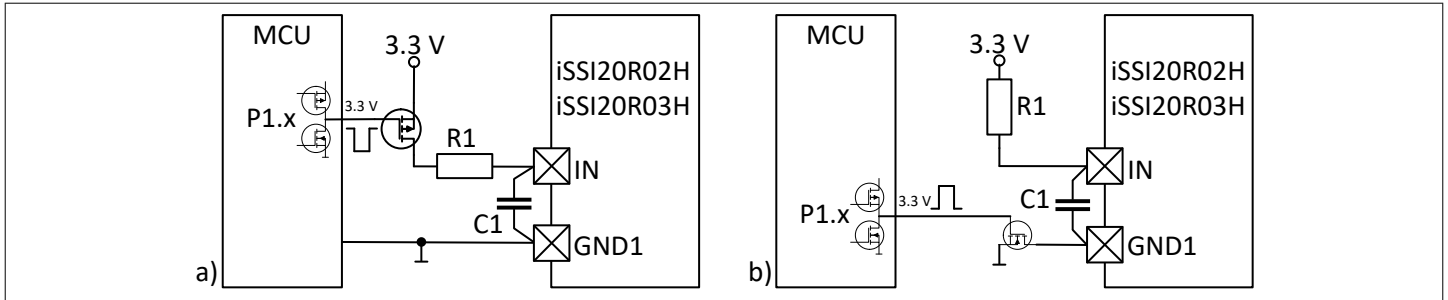
The middle part depicts a simple option for the supply scheme for iSSI20R02H, iSSI20R03H and iSSI20R11H. Terminal *IN* is connected to 3.3V and terminal *GND1* is connected to the driving port of the microcontroller. The Infineon SSI's output is inverted to the control signal at *IN*. This option requires ports that are able to sink at least the maximum value of  $I_{IN}$ , otherwise the effective supply voltage  $V_{IN} - V_{GND1}$  may not reach 3.3 V and the IC can stay in the under-voltage lockout mode.

Option c) connects the supply terminal *VCC1* to a higher voltage than 3.3 V, for example 24 V. In these cases, resistor *R2* acts as a current limiting resistor. The value for the current limit is the typical value of  $I_{VCC1}$ . This results in a limiting resistor value of

$$R2 = \frac{V_{\text{supply}} - V_{VCC1, \text{op, max}}}{I_{VCC1, \text{typ}}} = \frac{24 \text{ V} - 3.5 \text{ V}}{16 \text{ mA}} = 1281 \Omega \quad (1)$$

A selection of  $R2 = 1.3 \text{ k}\Omega$  is sufficient. Of course, worst-case conditions and tolerances of the supply voltage  $V_{\text{supply}}$  need to be considered, too. It is easy to understand that the solution using a current limiting resistor is not efficient as the resistor might dissipate noticeable power. Dimensioning *R2* according to the maximum supply current  $I_{VCC1, \text{max}}$  yields in higher losses inside the IC. Particularly when operating several Infineon SSI isolators, it is often more efficient to place a DC/DC-converter with a low-tolerance output voltage of 3.3 V instead of using a current limiting resistor for each Infineon SSI.

Very simple microcontroller have often no high current I/O-terminals. In such cases, an interface inverter is a solution for driving iSSI20R02H and iSSI20R03H. Such options using small-signal FETs are given in this figure.



**Figure 19** Interfacing with an inverter circuit

## 7.2 Grounding reference of current and temperature sensor signals

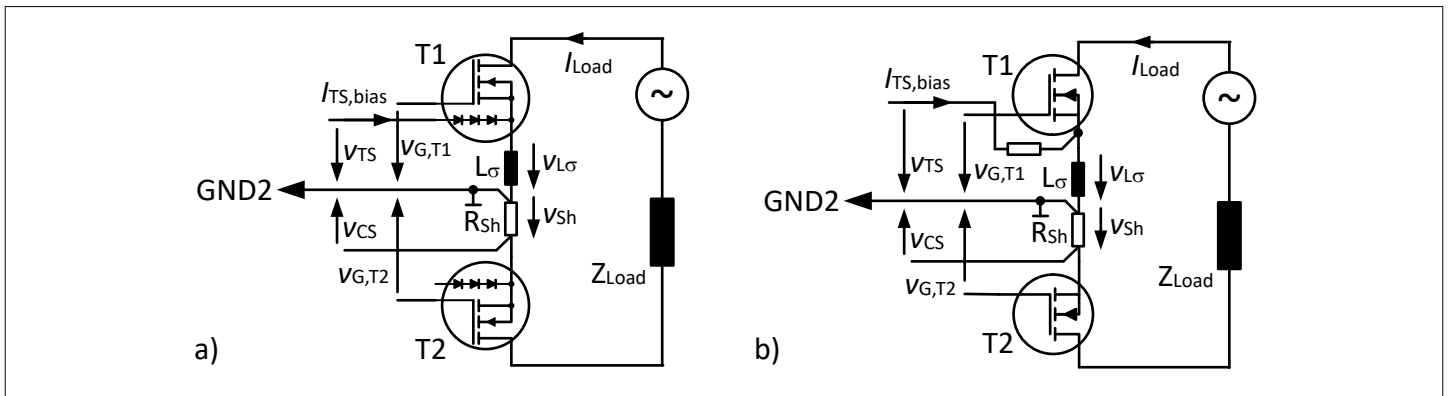
The two sensor signals of the current sensor (shunt) and the temperature sensor have to refer to a single ground reference. It is good engineering to refer the overall ground to one of the sensors.

The left part shows an AC-switch configuration using, for example, two MOSFETs with an integrated temperature sensor and with a shunt resistor for the instantaneous current measurement. The current measurement is more time critical compared to the temperature sensing as it needs to react within a few hundreds of nanoseconds. Therefore, one of the shunt terminals is taken as the reference of the sensor signals. The example utilizes the upper terminal of the shunt resistor  $R_{Sh}$  as the reference GND2. Direct connection of PCB traces from terminal GND2 to the shunt and parallel routing of the current sense signal and its reference GND2 is mandatory to achieve smallest signal distortion and filtering effort.

It is recommended to place the shunt in closest proximity to T1 in order to keep the stray inductance  $L_{\sigma}$  as small as possible. Any stray inductance of the layout is of course detrimental for the temperature sense voltage  $v_{TS}$  signal quality. However, the temperature sensing can be filtered easier because the thermal capacity of the switch allows temperature increases only in the range of hundreds of microseconds or even more. It is important in an AC-switch configuration that the temperature sensor of T2 is not connected. In case of paralleling several MOSFETs, the temperature sensor of only one MOSFET has to be connected

Please note that the gate voltage of T1  $v_{G,T1}$  is directly referenced to GND2 while the gate voltage of T2  $v_{G,T2}$  is lowered by means of the shunt voltage  $v_{Sh}$ .

The right part of the figure below depicts the option of using a PTC resistor as a temperature sensor element. All aspects for placing and routing the current sensor signals apply in the same way. The PTC resistor requires a good thermal coupling to the source pad of T1. The stray inductance  $L_{\sigma}$  is still active, but the good thermal coupling is a superior target to achieve than the minimization of the stray inductance.



**Figure 20** Grounding scheme for AC-switch with integrated temperature sensor (a) and with PTC temperature sensor (b)

In DC-switch configurations, all aspects for placing and routing the current sensor and the temperature sensor signals apply in the same way as for AC-switch configurations.



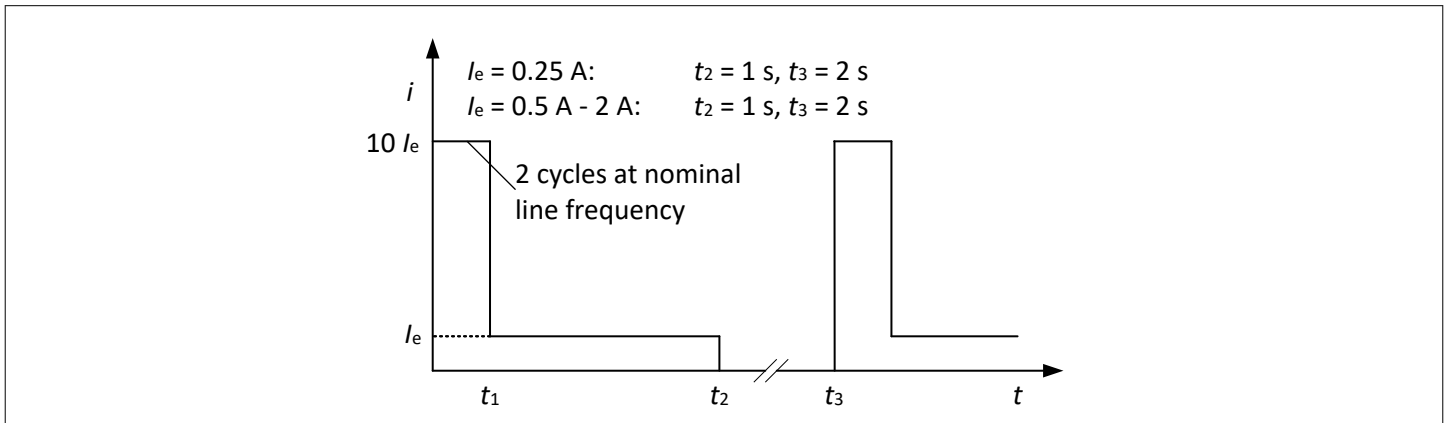
For a.c. switch using two CoolMOS™ IPT60R022S7, a drain-source voltage of 300 V, and a minimum gate-source voltage  $V_{G,min} = 7\text{ V}$ , the minimum buffer capacitance  $C_{BUF,min}$  yields in:

$$C_{BUF,min} = 1.2 \cdot \frac{100\text{ nC} + 70\text{ nC}}{10\text{ V} - 7\text{ V}} = 68\text{ nF} \quad (3)$$

## 7.4 Using the overcurrent protection

The overcurrent protection is designed to react fast on the detection of excessive current using a shunt. This chapter explains how to use this feature for the example of a relay that is able to operate AC-15 loads.

The AC-15 test is a generic test for electromechanical relays and for solid-state relays. Its test scheme is shown in the figure below. It brings demanding requirements for the dimensioning of the overcurrent protection. The protection should not trigger during the first interval of the AC-15 test when a load current of 10 x of the nominal current is applied to the device under test followed by the interval  $t_2 - t_1$  with nominal load current.



**Figure 23 AC-15 test (source: IEC 60947-1:2021)**

In addition, there are test requirements for the power factor at make and break for various conditions and tests. The power factor itself does not influence the current amplitude and is therefore not considered. This is an example for the shunt calculation for use in a solid-state relay with a current rating of 2 A supporting AC-15 tests.

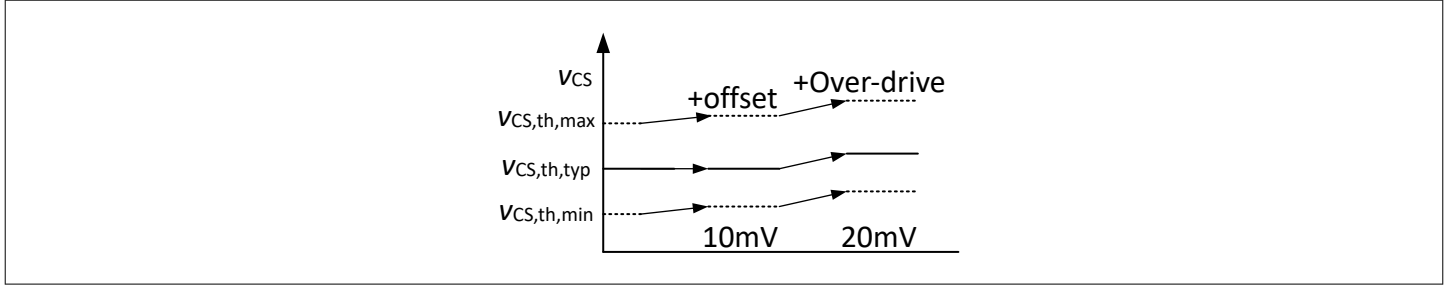
The maximum load current in the AC-15 test is 10 x the nominal and might appear at the maximum tolerated grid voltage which is 10% above nominal.

$$I_{pk,max} = 1.1 \cdot \sqrt{2} \cdot 2\text{ A} \cdot 10 = 31.1\text{ A peak} \quad (4)$$

The worst-case analysis needs a margin of the target protection trigger current with respect to the calculated value  $I_{pk,max,max}$ . The target protection trigger current is selected for  $I_{pk,trig} = 32\text{ A peak}$ . The overcurrent protection comparator is tolerated with +/- 15mV around the typical value of  $v_{CS,th}$  and an offset of 10 mV according to the figure below. Together with the assumed overdrive of the comparator of 20 mV, the minimum and maximum trigger currents are

$$I_{pk,trig,min} = I_{pk,trig} \frac{v_{CS,th,min} + 10\text{ mV} + 20\text{ mV}}{v_{CS,th,typ} + 20\text{ mV}} = 31.27\text{ A peak}$$

$$I_{pk,trig,max} = I_{pk,trig} \frac{v_{CS,th,max} + 10\text{ mV} + 20\text{ mV}}{v_{CS,th,typ} + 20\text{ mV}} = 35.64\text{ A peak} \quad (5)$$



**Figure 24** Worst-case current sense trigger thresholds

The dimensioning of the minimum shunt resistance follows this equation using the lowest trigger threshold including offset and overdrive and the maximum peak trigger current  $I_{pk, trig, max}$

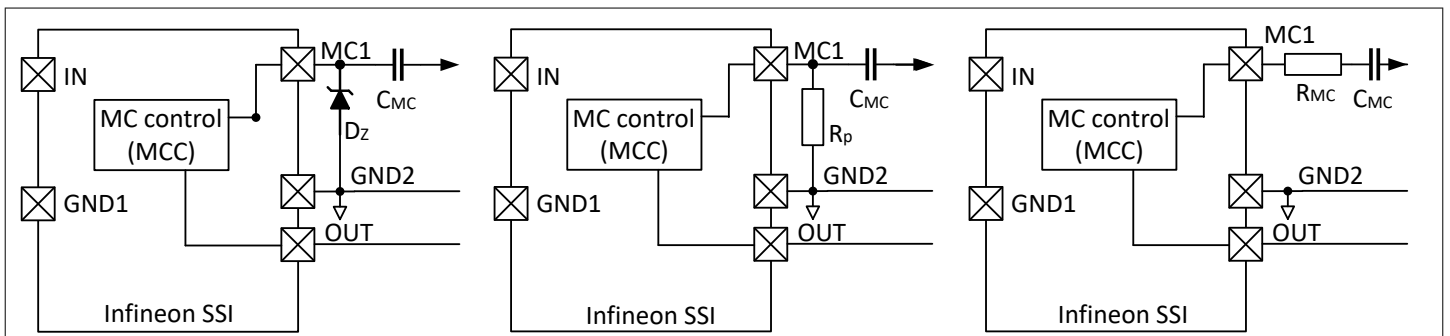
$$R_{Sh, max} = \frac{V_{CS, th, min} + 10 \text{ mV} + 20 \text{ mV}}{I_{pk, trig, max}} = \frac{215 \text{ mV}}{35.64 \text{ A}} = 6.033 \text{ m}\Omega \quad (6)$$

The above equation results in a selected resistance of  $R_{Sh} = 6 \text{ m}\Omega$ .

### 7.5 Using the dynamic Miller clamping

Connecting a capacitor between the input terminals  $MC$ ,  $MC1$  or  $MC2$  and the drain terminals of the switching transistor activates the dynamic Miller clamping feature that is available in variants iSSI20R02H and iSSI30R1xH. Let terminals  $MC$ ,  $MC1$  or  $MC2$  float to deactivate the feature. The dynamic Miller clamp reinforces the strong, yet limited pull-down capability of Infineon SSI in case that high  $dv_{DS}/dt$  events occur at the switched transistors. This is in particular important during off-state, if fast electric transients (bursts) occur. Even though there is usually no dedicated gate resistor in use, transients might lead to a parasitic turn-on of the switched transistor by pulling the gate higher than its gate-source threshold voltage.

The dimensioning of the coupling capacitors considers the fastest occurring  $dv_{DS}/dt$ -rates that appear in the application. In a.c. applications, bursts according to IEC 61000-4-4 can be a reference that specifies very steep pulses. However, the resulting pulses that stress the device-under-test have a lower amplitude and slope due to the cabling inductance and capacitance. An assumption for  $dv_{DS}/dt$  can be, for example, 10 V/ns and the coupling capacitance may be 1 pF. Please note that one of the two capacitors is shorted bypassed to GND2 by the related switched transistor in parallel. Thus, the only one capacitor is coupling the  $dv_{DS}/dt$  signal.



**Figure 25** Dynamic Miller clamp options with zener diode (left), parallel resistor (middle) and series resistor (right)

In the above mentioned example, the coupled capacitive current into terminal  $MC$  is  $10 \text{ V/ns} * 1 \text{ pF} = 10 \text{ nA}$ . This would generate a voltage at terminal  $MC$  of  $10 \text{ nA} * R_{MC} = 5 \text{ V}$ . Even though the static absolute maximum voltage rating at  $MC$  is  $V_{MC} = 3.6 \text{ V}$ , the dynamic current  $I_{MC, dyn}$  for sporadic events (duty cycle < 1%, pulse duration < 1  $\mu\text{s}$ ) that is injected into this terminal can be applied for pulsed stress. Therefore, clamping elements, such as a 3.3 V clamping zener diode at terminal  $MC$  to reduce voltages above the zener voltage might not be needed. However, special needs

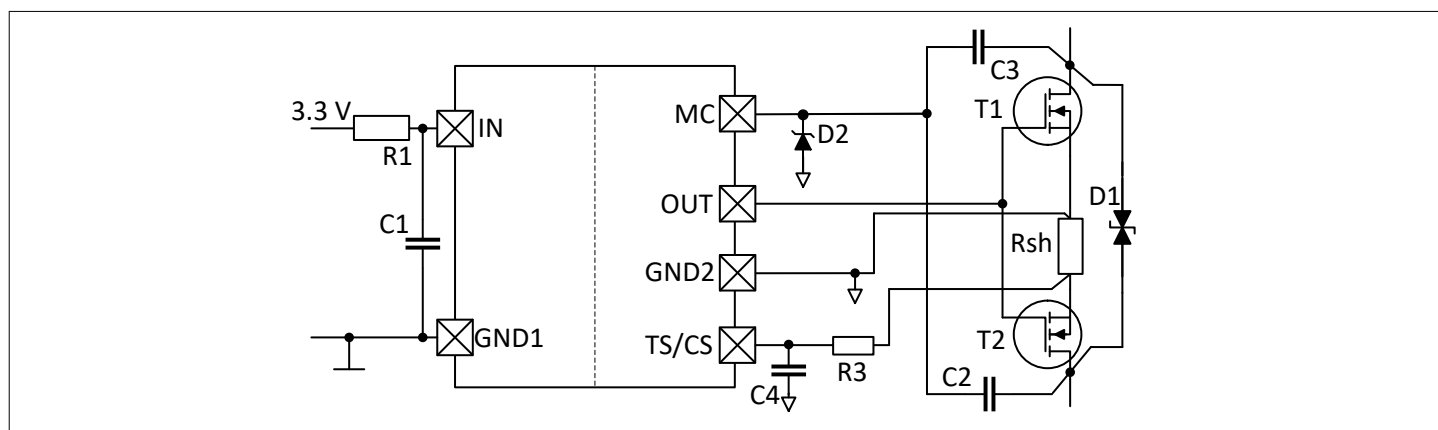
to be taken at the evaluation of the highest  $dv/dt$  in systems. Other clamping options are a resistor between terminal *MC* and *GND2* that would take a portion of the coupled capacitive current or applying a series resistor that generates enough voltage to keep the limits according to the figure above.

## 7.6 Inductive energy clamping methods

Solid-state relays are often used in combination with loads that have an inductive portion. The inductive portion generates an over-voltage, if the isolator's output is turned off. The amplitude of the over-voltage can exceed the switching transistor's maximum breakdown voltage. Therefore, a clamping element is needed to limit the drain-source voltage of the switching transistor. Various options are possible:

- TVS (transient voltage suppressor) diodes,
- varistors,
- snubbers and
- others

Special care is required for the dimensioning and selection of the related components depending on the application's operating range. For example, two or even more TVS diodes can be required to fulfill the datasheet of the clamping element. Also combinations of the above mentioned options can help for a optimized clamping solution.



**Figure 26** Example of a drain-to-drain TVS-diode D1 as a clamping element in an AC-switch configuration using iSSI20R02H

## 8 Related products

Infineon is providing this information as a courtesy only and without acknowledging any legal obligation. Information in the this chapter is not part of the Infineon component specification, and Infineon does not warrant its accuracy or completeness. Infineon's customers are responsible for determining suitability of components for their purposes. Customers should validate and test their design implementation to confirm system functionality.

Product group	Product name	Description
Infineon SSI solid-state isolators	<a href="#">Eval-iSSI30R12H</a>	Solid-state relay featuring over-temperature protection, overcurrent protection, dynamic miller clamping and fast turn-on with 600 V, 22 mΩ CoolMOS™ S7 (integrated temperature sensor)
Infineon SSI solid-state isolators	<a href="#">Eval-iSSI30R11H</a>	Solid-state relay featuring over-temperature protection (PTC), overcurrent protection, dynamic miller clamping and fast turn-on with 600 V, 10 mΩ CoolMOS™ S7
Infineon SSI solid-state isolators	<a href="#">Eval-iSSI20R11H</a>	solid-state relay featuring overcurrent protection and fast turn-on and 600 V, 65 mΩ CoolMOS™ S7
Infineon SSI solid-state isolators	<a href="#">Eval-iSSI20R03H</a>	Solid-state relay featuring over-temperature protection (PTC), overcurrent protection, and standard turn-on with 100 V, 3.5 mΩ MOSFETs in source-to-source configuration
Infineon SSI solid-state isolators	<a href="#">Eval-iSSI20R02HCS</a>	Solid-state relay featuring overcurrent protection, dynamic miller clamping and standard turn-on with 60 V, 1.5 mΩ MOSFETs in source-to-source configuration
Infineon SSI solid-state isolators	<a href="#">Eval-iSSI20R02HTS</a>	Solid-state relay featuring over-temperature protection (PTC), dynamic miller clamping and standard turn-on with 100 V, 3.5 mΩ MOSFETs in source-to-source configuration
CoolMOS™ S7 discrete MOSFETs with and without integrated temperature sensor	<a href="#">IPT60R065S7 / IPT60T065S7</a>	600 V, 65 mΩ MOSFET in TO-leadless (HSOF-8) / incl. integrated temperature sensor
	<a href="#">IPT60R040S7 / IPT60T040S7</a>	600 V, 40 mΩ MOSFET in TO-leadless (HSOF-8) / incl. integrated temperature sensor
	<a href="#">IPT60R022S7 / IPT60T022S7</a>	600 V, 22 mΩ MOSFET in TO-leadless (HSOF-8) / incl. integrated temperature sensor
	<a href="#">IPQC60R022S7 / IPQC60T022S7</a>	600 V, 22 mΩ MOSFET in QDPAK bottom-side cooled package (HDSOP) / incl. integrated temperature sensor
	<a href="#">IPQC60R017S7 / IPQC60T017S7</a>	600 V, 17 mΩ MOSFET in QDPAK bottom-side cooled package (HDSOP) / incl. integrated temperature sensor
	<a href="#">IPQC60R010S7 / IPQC60T010S7</a>	600 V, 10 mΩ MOSFET in QDPAK bottom-side cooled package (HDSOP) / incl. integrated temperature sensor
	<a href="#">IPDQ60R010S7 / IPDQ60T010S7</a>	600 V, 10 mΩ MOSFET in QDPAK top-side cooled package (HDSOP) / incl. integrated temperature sensor
	<a href="#">IPDQ60R017S7 / IPDQ60T017S7</a>	600 V, 17 mΩ MOSFET in QDPAK top-side cooled package (HDSOP) / incl. integrated temperature sensor
	<a href="#">IPDQ60R022S7 / IPDQ60T022S7</a>	600 V, 22 mΩ MOSFET in QDPAK top-side cooled package (HDSOP) / incl. integrated temperature sensor
	<a href="#">IPDQ60R040S7</a>	600 V, 40 mΩ MOSFET in QDPAK top-side cooled package (HDSOP)
	<a href="#">IPDQ60R065S7</a>	600 V, 65 mΩ MOSFET in QDPAK top-side cooled package (HDSOP)

**8 Related products**

<b>Product group</b>	<b>Product name</b>	<b>Description</b>
OptiMOS™ Linear FET, discrete MOSFETs	<a href="#">IPT008N06NM5LF</a>	60 V, 0.8 mΩ MOSFET in TO-leadless (HSOF-8)
	<a href="#">IPT013N08NM5LF</a>	80 V, 1.3 mΩ MOSFET in TO-leadless (HSOF-8)
	<a href="#">IPB017N10N5LF</a>	100 V, 1.7 mΩ MOSFET in D2PAK 7pin (TO-263 7pin)
	<a href="#">IPB020N10N5LF</a>	100 V, 2.0 mΩ MOSFET in D2PAK 7pin (TO-263 7pin)
	<a href="#">IPB033N10N5LF</a>	100 V, 3.3 mΩ MOSFET in D2PAK (PG-TO263-3)
	<a href="#">IPB048N15N5LF</a>	150 V, 4.8 mΩ MOSFET in D2PAK (PG-TO263-3)
	<a href="#">IPB083N15N5LF</a>	150 V, 8.3 mΩ MOSFET in D2PAK (PG-TO263-3)
	<a href="#">IPB110N20N3LF</a>	200 V, 11 mΩ MOSFET in D2PAK (PG-TO263-3)

## 9 Package dimensions

### 9.1 Package outline

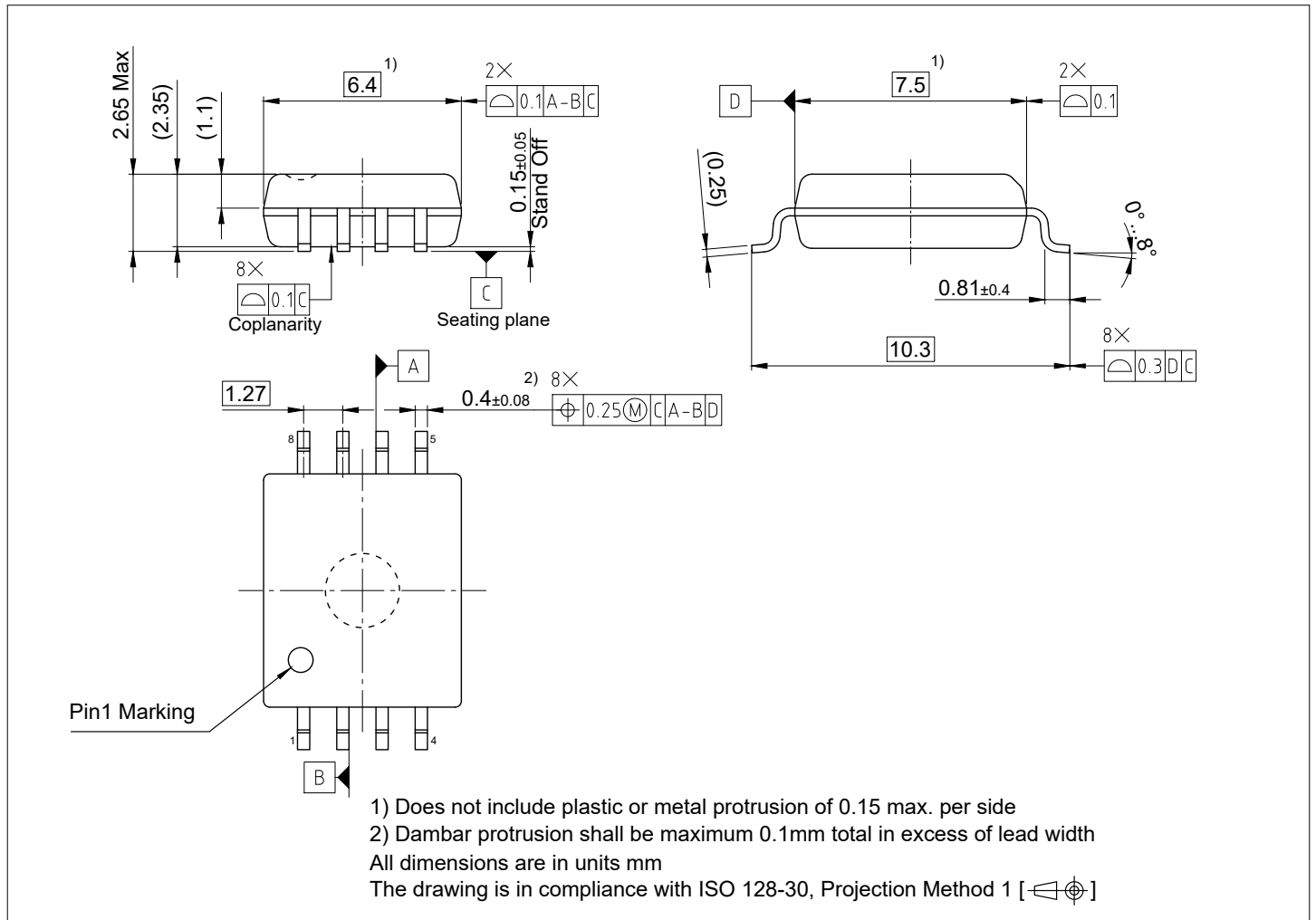
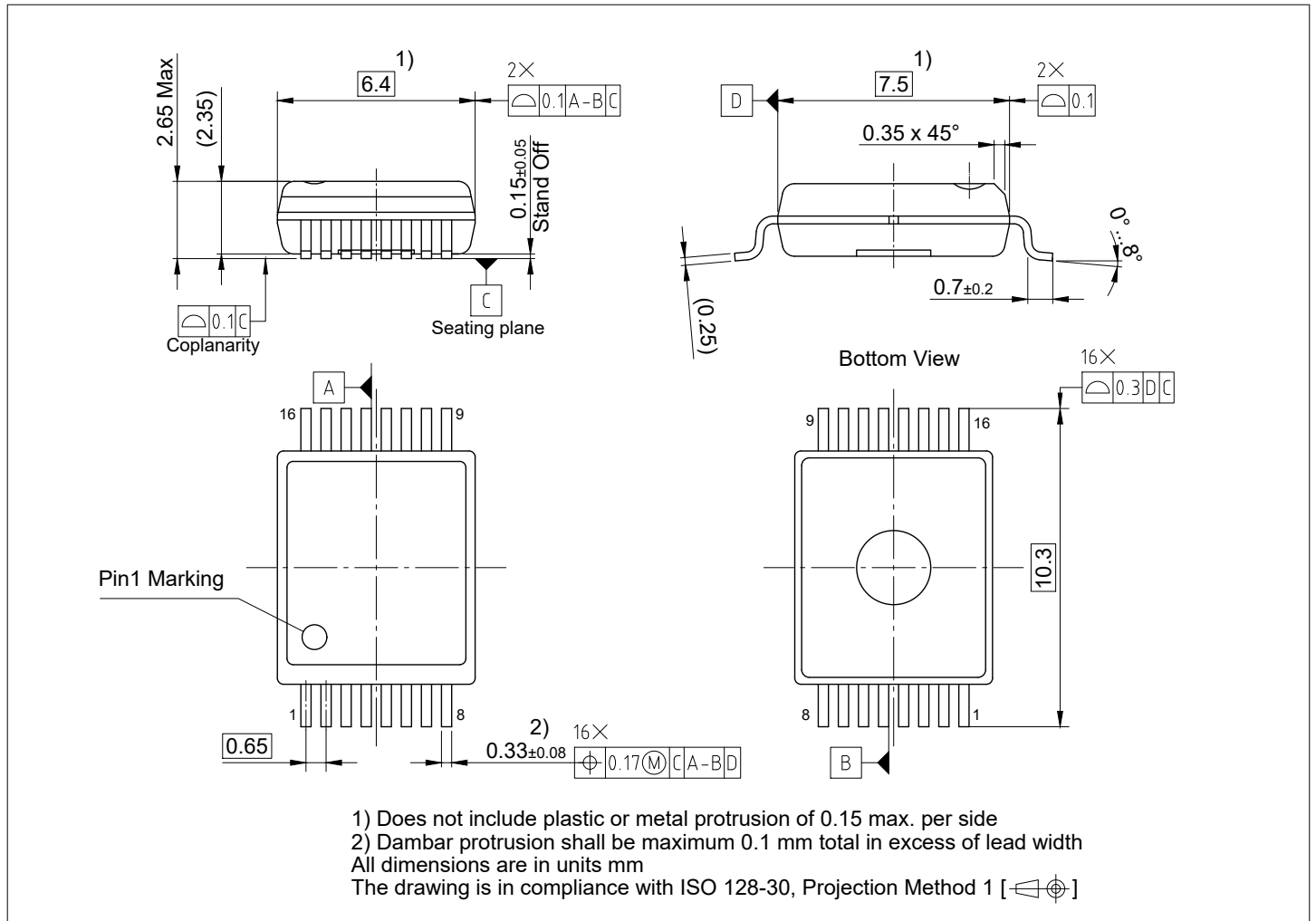


Figure 27 PG-DSO-8-66



**Figure 28** PG-DSO-16-33

## Revision history

Document version	Date of release	Description of changes
v1.00	2024-01-29	<ul style="list-style-type: none"><li>Initial release</li></ul>
v1.10	2024-08-28	<ul style="list-style-type: none"><li>Short circuit output current value for iSSI20R02H and iSSI20R03H update</li><li>Certification information update (UL certification)</li><li>Term “iSSI” replace with “Infineon SSI”</li><li>Timing diagrams update</li></ul>
v1.11	2025-04-01	<ul style="list-style-type: none"><li>Description update</li><li>Timing diagram update</li><li>Clarification of test conditions and output voltage update</li><li>Pin description update</li><li>Added note to parameter <math>C_{TS,ext}</math></li><li>Fig. 19 update</li></ul>

## Trademarks

All referenced product or service names and trademarks are the property of their respective owners.

**Edition 2025-04-16**

**Published by**

**Infineon Technologies AG**

**81726 Munich, Germany**

**© 2025 Infineon Technologies AG**

**All Rights Reserved.**

**Do you have a question about any aspect of this document?**

**Email: [erratum@infineon.com](mailto:erratum@infineon.com)**

**Document reference**

**IFX-tpr1651059224683**

## Important notice

The information given in this document shall in no event be regarded as a guarantee of conditions or characteristics ("Beschaffheitsgarantie").

With respect to any examples, hints or any typical values stated herein and/or any information regarding the application of the product, Infineon Technologies hereby disclaims any and all warranties and liabilities of any kind, including without limitation warranties of non-infringement of intellectual property rights of any third party.

In addition, any information given in this document is subject to customer's compliance with its obligations stated in this document and any applicable legal requirements, norms and standards concerning customer's products and any use of the product of Infineon Technologies in customer's applications.

The data contained in this document is exclusively intended for technically trained staff. It is the responsibility of customer's technical departments to evaluate the suitability of the product for the intended application and the completeness of the product information given in this document with respect to such application.

## Warnings

Due to technical requirements products may contain dangerous substances. For information on the types in question please contact your nearest Infineon Technologies office.

Except as otherwise explicitly approved by Infineon Technologies in a written document signed by authorized representatives of Infineon Technologies, Infineon Technologies' products may not be used in any applications where a failure of the product or any consequences of the use thereof can reasonably be expected to result in personal injury.