

FEATURES

- High Reliability Proven Design
- DCR4160A42
- Forced Air Cooling
- Redundant Fan (Optional)
- RC Snubber
- Pressure Switch
- IR Temperature Sensor (Optional)
- DC Fuse (Optional)
- Gate Drive (Optional)
- Easily Maintainable Design

APPLICATIONS

- Power Generation
- Renewables

The Dynex Standard Assemblies range consists of proven high reliability Heatsink Assemblies for a challenging range of applications.

The DSS1300AP1-B6C-1700 is a controlled bridge rectifier spread across 3 individual phase arm assemblies. The forced air-cooled design has been optimised for high reliability operation for deployment in applications that require continuous operation and long lifetime. The Thyristor characteristics have been tailored specifically to lower the overall losses of the assembly to improve reliability as well as increase efficiency.

The design can be altered to suit a specific application requirement. Contact your local representative to find out more.

KEY PARAMETERS

I_{dc}	(max)	1300A
V_{ac}		1200V
P	(max)	2250kVA

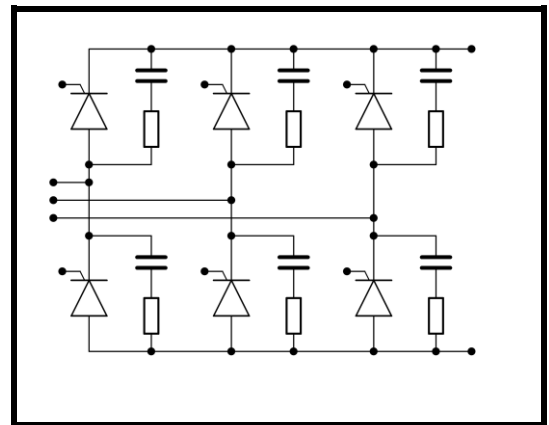
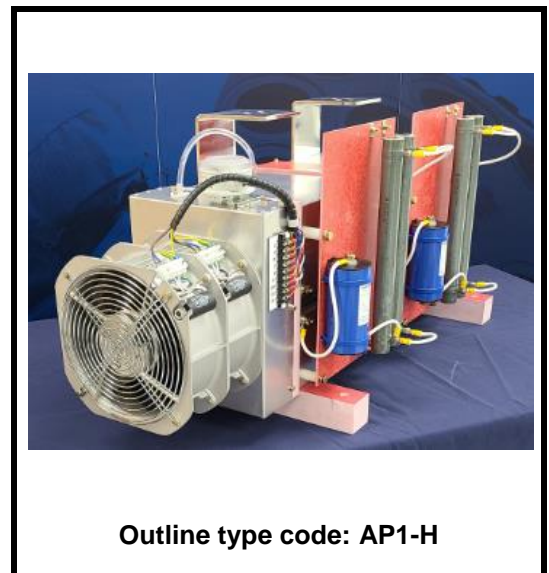

Fig. 1 Circuit configuration



Outline type code: AP1-H

**Fig. 2 Package
(Image shows 1 phase arm)**

Symbol	Parameter	Min.	Typ.	Max.	Units
	Electrical Characteristics				
I_{dc}	DC Current Continuous (50 Hz) - $T_{Air Inlet} = 40^{\circ}C$			1300	A
V_{AC}			1200		V
V_{DC}				1700	V
P_{Total}				2250	kVA
V_{ISO}	50Hz 1min			6.0	kV _{ac}
X	Assumed Transformer Reactance	6			%
	Mechanical/Environmental				
Weight	Per phase		50		Kg
PD	Pollution Degree (EN 50178)		2		
	Fan Noise		59		dB
IP	Ingress Protection (EN 60529)		00		
	Pressure Switch Aux Contact Current (230V _{ac})			0.5	A
	Fan Data				
V_{Fan}	Fan voltage		230		V _{ac}
f_{Fan}	Fan Frequency		50 / 60		Hz
P_{Fan}	Fan Power		74 / 80		W
	Snubber – per Thyristor				
R			55		Ω
C			0.33		μF

PACKAGE DETAILS

For further package information, please visit our website or contact Customer Services.
 All dimensions in mm, unless stated otherwise.
DO NOT SCALE.

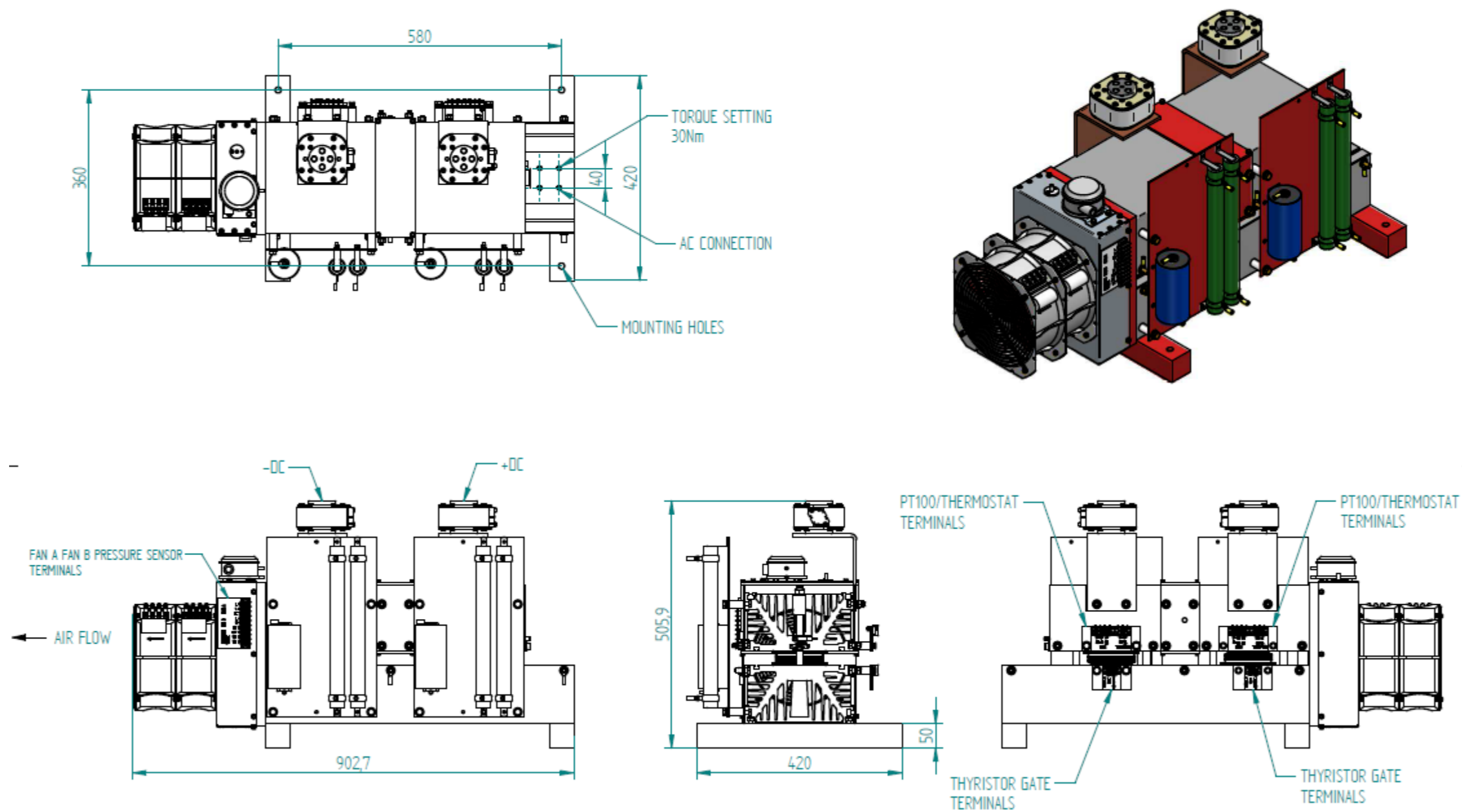

Nominal Weight: 50kg

Module Outline Type Code: AP1-H

Fig. 3 Outline drawing of one Phase Arm (3 assemblies required per Bridge)

IMPORTANT INFORMATION:

This publication is provided for information only and not for resale.

The products and information in this publication are intended for use by appropriately trained technical personnel.

Due to the diversity of product applications, the information contained herein is provided as a general guide only and does not constitute any guarantee of suitability for use in a specific application. The user must evaluate the suitability of the product and the completeness of the product data for the application. The user is responsible for product selection and ensuring all safety and any warning requirements are met. Should additional product information be needed please contact Customer Service.

Although we have endeavoured to carefully compile the information in this publication it may contain inaccuracies or typographical errors. The information is provided without any warranty or guarantee of any kind.

This publication is an uncontrolled document and is subject to change without notice. When referring to it please ensure that it is the most up to date version and has not been superseded.

The products are not intended for use in applications where a failure or malfunction may cause loss of life, injury or damage to property. The user must ensure that appropriate safety precautions are taken to prevent or mitigate the consequences of a product failure or malfunction.

The products must not be touched when operating because there is a danger of electrocution or severe burning. Always use protective safety equipment such as appropriate shields for the product and wear safety glasses. Even when disconnected any electric charge remaining in the product must be discharged and allowed to cool before safe handling using protective gloves.

Extended exposure to conditions outside the product ratings may affect reliability leading to premature product failure. Use outside the product ratings is likely to cause permanent damage to the product. In extreme conditions, as with all semiconductors, this may include potentially hazardous rupture, a large current to flow or high voltage arcing, resulting in fire or explosion. Appropriate application design and safety precautions should always be followed to protect persons and property.

Product Status & Product Ordering:

We annotate datasheets in the top right hand corner of the front page, to indicate product status if it is not yet fully approved for production. The annotations are as follows:

Target Information:	This is the most tentative form of information and represents a very preliminary specification. No actual design work on the product has been started.
Provisional Information:	Some initial development work has been performed. The datasheet represents a view of the end product based on very limited information. Certain details will change.
Preliminary Information:	The product design is complete and final characterisation for volume production is in progress. The datasheet represents the product as it is now understood but details may change.
No Annotation:	The product has been approved for production and unless otherwise notified by Dynex any product ordered will be supplied to the current version of the data sheet prevailing at the time of our order acknowledgement.

All products and materials are sold and services provided subject to Dynex's conditions of sale, which are available on request.

Any brand names and product names used in this publication are trademarks, registered trademarks or trade names of their respective owners.

HEADQUARTERS OPERATIONS

DYNEX SEMICONDUCTOR LIMITED
Doddington Road, Lincoln, Lincolnshire. LN6 3LF
United Kingdom.
Phone: +44 (0) 1522 500500
Fax: +44 (0) 1522 500550
Web: <http://www.dynexsemi.com>

CUSTOMER SERVICE

Phone: +44 (0) 1522 502753 / 502901
e-mail: powersolutions@dynexsemi.com