

Product Overview

The NSI823x devices are high reliability triple-channel digital isolators. The NSI823x device is safety certified by UL1577 support several insulation withstand voltages (3kVrms, 3.75kVrms, 5kVrms, 8kVrms), while providing high electromagnetic immunity and low emissions at low power consumption. The data rate of the NSI823x is up to 150Mbps, and the common-mode transient immunity (CMTI) is up to 250kV/us. The NSI823x device provides digital channel direction configuration and the default output level configuration when the input power is lost. Wide supply voltage of the NSI823x device supports to connect with most digital interface directly, easy to do the level shift. High system level EMC performance enhance reliability and stability of use.

Key Features

- Up to 8000V_{rms} Insulation voltage
- Data rate: DC to 150Mbps
- Power supply voltage: 2.5V to 5.5V
- High CMTI: 250kV/us
- Chip level ESD: HBM: ±8kV
- Robust Electromagnetic Compatibility (EMC)
 - System-Level ESD, EFT, and Surge Immunity
 - Low Emissions
- Default output high level or low level option
- Low power consumption: 1.5mA/ch (1 Mbps)
- Low propagation delay: <15ns
- Operation temperature: -55°C~125°C
- RoHS-compliant packages:
 - SOP16(150mil)
 - SOP16(300mil)
 - SOP16(600mil)
 - SSOP16

Safety Regulatory Approvals

- UL recognition: up to 8000V_{rms} for 1 minute per UL1577
- CQC certification per GB4943.1
- CSA component notice 5A
- DIN EN IEC 60747-17 (VDE 0884-17)

Applications

- Industrial automation system
- Isolated SPI, RS232, RS485
- General-purpose multichannel isolation
- Motor control

Device Information

Part Number	Package	Body Size
NSI823xNx-DSPNR	SOP16(150mil)	9.90mm x 3.90mm
NSI823xSx-DSSR	SSOP16	4.90mm x 3.90mm
NSI823xWx-DSWR	SOP16(300mil)	10.30mm x 7.50mm
NSI823xWx-DSWWR	SOP16(600mil)	10.52mm x 14.0mm

Functional Block Diagrams

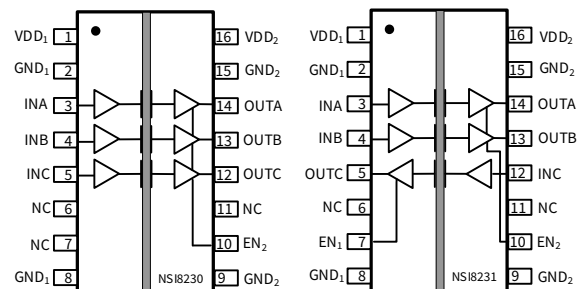

Figure 1. NSI823x Block Diagram

INDEX

1. PIN CONFIGURATION AND FUNCTIONS	3
2. ABSOLUTE MAXIMUM RATINGS	3
3. RECOMMENDED OPERATING CONDITIONS	4
4. THERMAL INFORMATION	4
5. SPECIFICATIONS	5
5.1. ELECTRICAL CHARACTERISTICS	5
5.2. SUPPLY CURRENT CHARACTERISTICS – 5V SUPPLY	6
5.3. SUPPLY CURRENT CHARACTERISTICS –3.3V SUPPLY	7
5.4. SUPPLY CURRENT CHARACTERISTICS–2.5V SUPPLY	8
5.5. SWITCHING CHARACTERISTICS - 5V SUPPLY	9
5.6. SWITCHING CHARACTERISTICS - 3.3V SUPPLY	9
5.7. SWITCHING CHARACTERISTICS - 2.5V SUPPLY	10
5.8. TYPICAL PERFORMANCE CHARACTERISTICS	11
5.9. PARAMETER MEASUREMENT INFORMATION	12
6. HIGH VOLTAGE FEATURE DESCRIPTION	13
6.1. INSULATION AND SAFETY RELATED SPECIFICATIONS	13
6.2. INSULATION CHARACTERISTICS	14
6.3. SAFETY-LIMITING VALUES	16
6.4. REGULATORY INFORMATION	18
7. FUNCTION DESCRIPTION	19
7.1. OVERVIEW	20
7.2. OOK MODULATION	21
8. APPLICATION NOTE	22
8.1. TYPICAL APPLICATION CIRCUIT	22
8.2. PCB LAYOUT	22
8.3. HIGH SPEED PERFORMANCE	23
8.4. TYPICAL SUPPLY CURRENT EQUATIONS	23
9. PACKAGE INFORMATION	24
10. ORDER INFORMATION	28
11. DOCUMENTATION SUPPORT	29
12. TAPE AND REEL INFORMATION	30
13. REVISION HISTORY	35

1. Pin Configuration and Functions

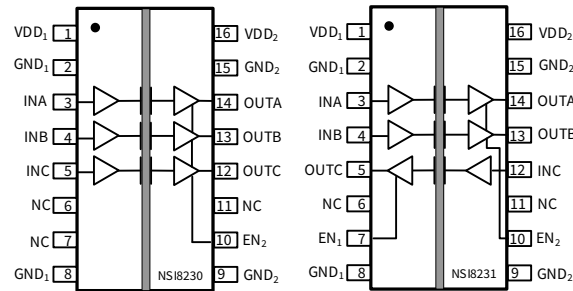

Figure 1.1 NSI823x Package

Table 1.1 NSI823x Pin Configuration and Description

NSI8230 PIN NO.	NSI8231 PIN NO.	SYMBOL	FUNCTION
1	1	VDD ₁	Power Supply for Isolator Side 1
2	2	GND ₁	Ground 1, the ground reference for Isolator Side 1
3	3	INA	Logic Input A
4	4	INB	Logic Input B
5	12	INC	Logic Input C
6	6	NC	No Connection.
7	7	NC /EN ₁	No Connection. Or Output Enable 1. Active high logic input. When EN ₁ is high or NC, the output of Side 1 is enabled. When EN ₁ is low, the output of Side 1 is disabled to high impedance state.
8	8	GND ₁	Ground 1, the ground reference for Isolator Side 1
9	9	GND ₂	Ground 2, the ground reference for Isolator Side 2
10	10	EN ₂	Output Enable 2. Active high logic input. When EN ₂ is high or NC, the output of Side 2 is enabled. When EN ₂ is low, the output of Side 2 is disabled to high impedance state.
11	11	NC	No Connection.
12	5	OUTC	Logic Output C
13	13	OUTB	Logic Output B
14	14	OUTA	Logic Output A
15	15	GND ₂	Ground 2, the ground reference for Isolator Side 2
16	16	VDD ₂	Power Supply for Isolator Side 2

2. Absolute Maximum Ratings

Parameters	Symbol	Min	Typ	Max	Unit	Comments
Power Supply Voltage	VDD1, VDD2	-0.5		6.5	V	
Maximum Input Voltage	VINA, VINB, VINC	-0.4		VDD+0.4	V	The maximum voltage must not exceed 6.5V
Maximum Output Voltage	VOUTA, VOUTB, VOUTC	-0.4		VDD+0.4	V	The maximum voltage must not exceed 6.5V
Maximum Input/Output Pulse Voltage	VINA, VINB, VINC, VOUTA, VOUTB, VOUTC	-0.8		VDD+0.8	V	Pulse width should be less than 100ns, and the duty cycle should be less than 10%
Output current	Io	-15		15	mA	
Operating Temperature	T _{opr}	-55		125	°C	
Junction Temperature	T _j			150	°C	
Storage Temperature	T _{stg}	-65		150	°C	
Electrostatic discharge	HBM			±8000	V	
	CDM			±2000	V	

3. Recommended Operating Conditions

Parameters	Symbol	min	typ	max	unit
Power Supply Voltage	VDD1, VDD2	2.5		5.5	V
Operating Temperature	T _{opr}	-55		125	°C
High Level Input Voltage	VIH	2			V
Low Level Input Voltage	VIL			0.8	V
Data rate	DR			150	Mbps

4. Thermal Information

Parameters	Symbol	SSOP16	SOP16(150mil)	SOP16(300mil)	SOP16(600mil)	Unit
IC Junction-to-Air Thermal Resistance	θ _{JA}	140	78.9	78.9	78.9	°C/W

Parameters	Symbol	SSOP16	SOP16(150mil)	SOP16(300mil)	SOP16(600mil)	Unit
Junction-to-case (top) thermal resistance	$\theta_{JC (top)}$	54.4	41.1	41.6	41.1	°C/W
Junction-to-board thermal resistance	θ_{JB}	51.9	49.5	43.6	49.5	°C/W

5. Specifications

5.1. Electrical Characteristics

(VDD1=2.5V~5.5V, VDD2=2.5V~5.5V, Ta=-55°C to 125°C. Unless otherwise noted, Typical values are at VDD1 = 5V, VDD2 = 5V, Ta = 25°C)

Parameters	Symbol	Min	Typ	Max	Unit	Comments
Power on Reset	VDD _{POR}	2	2.2	2.4	V	POR threshold as during power-up
	VDD _{HYS}		0.1		V	POR threshold Hysteresis
Rising input switching threshold	V _{IT+}		1.6	2	V	
Falling input switching threshold	V _{IT-}	0.8	1.2		V	
Input threshold voltage hysteresis	V _{I(HYS)}		0.4		V	
High Level Output Voltage	V _{OH}	VDD-0.4			V	I _{OH} = - 4mA
Low Level Output Voltage	V _{OL}			0.4	V	I _{OL} = 4mA
Output Impedance	R _{out}		50		ohm	
Input Pull high or low Current	I _{pull}		8	15	uA	
Start Up Time after POR	t _{rs}		10		us	
Common Mode Transient Immunity	CMTI	±200	±250		kV/us	See Figure 5.9 , C _L = 15pF

5.2. Supply Current Characteristics – 5V Supply

(VDD1=5V± 10%, VDD2=5V± 10%, Ta=-55°C to 125°C. Unless otherwise noted, Typical values are at **VDD1 = 5V, VDD2 = 5V, Ta = 25°C**)

Parameters	Symbol	Min	Typ.	Max	Unit	Comments
Supply current	NSI8230					
	I _{DD1} (Q0)		1.24	2.04	mA	All Input 0V for NSI8230x0 Or All Input at supply for NSI8230x1
	I _{DD2} (Q0)		2.94	4.84	mA	
	I _{DD1} (Q1)		4.25	7.02	mA	All Input at supply for NSI8230x0 Or All Input 0V for NSI8230x1
	I _{DD2} (Q1)		3.00	4.95	mA	
	I _{DD1} (1M)		2.43	4.00	mA	All Input with 1Mbps, C _L =15pF
	I _{DD2} (1M)		2.45	4.27	mA	
	I _{DD1} (10M)		2.92	4.82	mA	All Input with 10Mbps, C _L =15pF
	I _{DD2} (10M)		3.06	5.99	mA	
	I _{DD1} (100M)		3.97	7.93	mA	All Input with 100Mbps, C _L =15pF
	I _{DD2} (100M)		12.47	29.28	mA	
	NSI8231					
	I _{DD1} (Q0)		1.66	2.74	mA	All Input 0V for NSI8231x0 Or All Input at supply for NSI8231x1
	I _{DD2} (Q0)		2.51	4.14	mA	
	I _{DD1} (Q1)		3.69	6.09	mA	All Input at supply for NSI8231x0 Or All Input 0V for NSI8231x1
	I _{DD2} (Q1)		3.56	5.87	mA	
	I _{DD1} (1M)		2.31	3.81	mA	All Input with 1Mbps, C _L =15pF
	I _{DD2} (1M)		2.40	4.17	mA	
	I _{DD1} (10M)		2.75	4.53	mA	All Input with 10Mbps, C _L =15pF
	I _{DD2} (10M)		3.40	5.61	mA	
I _{DD1} (100M)		6.69	13.38	mA	All Input with 100Mbps, C _L = 15pF	
I _{DD2} (100M)		12.47	24.94	mA		

5.3. Supply Current Characteristics –3.3V Supply

(VDD1=3.3V± 10%, VDD2=3.3V± 10%, Ta=-55°C to 125°C. Unless otherwise noted, Typical values are at VDD1 = 3.3V, VDD2 = 3.3V, Ta = 25°C)

Parameters	Symbol	Min	Typ.	Max	Unit	Comments
Supply current	NSI8230					
	I _{DD1} (Q0)		1.19	1.96	mA	All Input 0V for NSI8230x0 Or All Input at supply for NSI8230x1
	I _{DD2} (Q0)		2.87	4.74	mA	
	I _{DD1} (Q1)		4.20	6.93	mA	All Input at supply for NSI8230x0 Or All Input 0V for NSI8230x1
	I _{DD2} (Q1)		2.93	4.83	mA	
	I _{DD1} (1M)		2.38	3.92	mA	All Input with 1Mbps, C _L =15pF
	I _{DD2} (1M)		2.37	4.14	mA	
	I _{DD1} (10M)		2.81	4.64	mA	All Input with 10Mbps, C _L =15pF
	I _{DD2} (10M)		2.66	5.27	mA	
	I _{DD1} (100M)		3.30	6.59	mA	All Input with 100Mbps, C _L =15pF
	I _{DD2} (100M)		10.01	20.01	mA	
	NSI8231					
	I _{DD1} (Q0)		1.61	2.66	mA	All Input 0V for NSI8231x0 Or All Input at supply for NSI8231x1
	I _{DD2} (Q0)		2.45	4.04	mA	
	I _{DD1} (Q1)		3.64	6.00	mA	All Input at supply for NSI8231x0 Or All Input 0V for NSI8231x1
	I _{DD2} (Q1)		3.49	5.76	mA	
	I _{DD1} (1M)		2.25	3.71	mA	All Input with 1Mbps, C _L =15pF
	I _{DD2} (1M)		2.34	4.06	mA	
	I _{DD1} (10M)		2.53	4.18	mA	All Input with 10Mbps, C _L =15pF
	I _{DD2} (10M)		3.00	4.94	mA	
I _{DD1} (100M)		5.42	10.84	mA	All Input with 100Mbps, C _L = 15pF	
I _{DD2} (100M)		10.01	20.01	mA		

5.4. Supply Current Characteristics–2.5V Supply

(VDD1=2.5V± 10%, VDD2=2.5V± 10%, Ta=-55°C to 125°C. Unless otherwise noted, Typical values are at VDD1 = 2.5V, VDD2 = 2.5V, Ta = 25°C)

Parameters	Symbol	Min	Typ.	Max	Unit	Comments
Supply current	NSI8230					
	I _{DD1} (Q0)		1.17	1.92	mA	All Input 0V for NSI8230x0 Or All Input at supply for NSI8230x1
	I _{DD2} (Q0)		2.83	4.66	mA	
	I _{DD1} (Q1)		4.14	6.83	mA	All Input at supply for NSI8230x0 Or All Input 0V for NSI8230x1
	I _{DD2} (Q1)		2.87	4.74	mA	
	I _{DD1} (1M)		2.30	3.80	mA	All Input with 1Mbps, C _L =15pF
	I _{DD2} (1M)		2.31	4.05	mA	
	I _{DD1} (10M)		2.70	4.46	mA	All Input with 10Mbps, C _L =15pF
	I _{DD2} (10M)		2.46	4.90	mA	
	I _{DD1} (100M)		2.85	5.70	mA	All Input with 100Mbps, C _L =15pF
	I _{DD2} (100M)		8.22	16.44	mA	
	NSI8231					
	I _{DD1} (Q0)		1.58	2.61	mA	All Input 0V for NSI8231x0 Or All Input at supply for NSI8231x1
	I _{DD2} (Q0)		2.41	3.98	mA	
	I _{DD1} (Q1)		3.58	5.90	mA	All Input at supply for NSI8231x0 Or All Input 0V for NSI8231x1
	I _{DD2} (Q1)		3.43	5.67	mA	
	I _{DD1} (1M)		2.18	3.60	mA	All Input with 1Mbps, C _L =15pF
	I _{DD2} (1M)		2.29	3.95	mA	
	I _{DD1} (10M)		2.39	3.95	mA	All Input with 10Mbps, C _L =15pF
	I _{DD2} (10M)		2.80	4.61	mA	
I _{DD1} (100M)		4.53	9.05	mA	All Input with 100Mbps, C _L = 15pF	
I _{DD2} (100M)		8.22	16.44	mA		

5.5. Switching Characteristics - 5V Supply

(VDD1=5V± 10%, VDD2=5V± 10%, Ta=-55°C to 125°C. Unless otherwise noted, Typical values are at VDD1 = 5V, VDD2 = 5V, Ta = 25°C)

Parameters	Symbol	Min	Typ.	Max	Unit	Comments
Data Rate	DR	0		150	Mbps	
Minimum Pulse Width	PW			5.0	ns	
Propagation Delay	t _{PLH}	2.5	6.54	15	ns	See Figure 5.7 , C _L = 15pF
	t _{PHL}	2.5	8.30	15	ns	See Figure 5.7 , C _L = 15pF
Pulse Width Distortion t _{PHL} - t _{PLH}	PWD			5.0	ns	See Figure 5.7 , C _L = 15pF
Rising Time	t _r			5.0	ns	See Figure 5.7 , C _L = 15pF
Falling Time	t _f			5.0	ns	See Figure 5.7 , C _L = 15pF
Peak Eye Diagram Jitter	t _{JIT(PK)}		350		ps	
Channel-to-Channel Delay Skew	t _{SK(c2c)}			2.5	ns	
Part-to-Part Delay Skew	t _{SK(p2p)}			5.0	ns	
Disable high to Tri-State	t _{PHZ}		10.0	30	ns	See Figure 5.8 , C _L = 15pF, R _L =1k
Enable to Data high Valid	t _{PZH}		8.3	30	ns	See Figure 5.8 , C _L = 15pF, R _L =1k
Disable low to Tri-State	t _{PLZ}		10.2	30	ns	See Figure 5.8 , C _L = 15pF, R _L =1k
Enable to Data low Valid	t _{PZL}		8.6	30	ns	See Figure 5.8 , C _L = 15pF, R _L =1k

5.6. Switching Characteristics - 3.3V Supply

(VDD1=3.3V± 10%, VDD2=3.3V± 10%, Ta=-55°C to 125°C. Unless otherwise noted, Typical values are at VDD1 = 3.3V, VDD2 = 3.3V, Ta = 25°C)

Parameters	Symbol	Min	Typ	Max	Unit	Comments
Data Rate	DR	0		150	Mbps	
Minimum Pulse Width	PW			5.0	ns	
Propagation Delay	t _{PLH}	2.5	7.5	15	ns	See Figure 5.7 , C _L = 15pF
	t _{PHL}	2.5	8.7	15	ns	See Figure 5.7 , C _L = 15pF
Pulse Width Distortion	PWD			5.0	ns	See Figure 5.7 , C _L = 15pF

Parameters	Symbol	Min	Typ	Max	Unit	Comments
$ t_{PHL} - t_{PLH} $						
Rising Time	t_r			5.0	ns	See Figure 5.7 , $C_L = 15pF$
Falling Time	t_f			5.0	ns	See Figure 5.7 , $C_L = 15pF$
Peak Eye Diagram Jitter	$t_{JIT}(PK)$		350		ps	
Channel-to-Channel Delay Skew	$t_{SK}(c2c)$			2.5	ns	
Part-to-Part Delay Skew	$t_{SK}(p2p)$			5.0	ns	
Disable high to Tri-State	t_{PHZ}		11.6	30	ns	See Figure 5.8 , $C_L = 15pF$, $R_L=1k$
Enable to Data high Valid	t_{PZH}		11.7	30	ns	See Figure 5.8 , $C_L = 15pF$, $R_L=1k$
Disable low to Tri-State	t_{PLZ}		14.5	30	ns	See Figure 5.8 , $C_L = 15pF$, $R_L=1k$
Enable to Data low Valid	t_{PZL}		11.8	30	ns	See Figure 5.8 , $C_L = 15pF$, $R_L=1k$

5.7. Switching Characteristics - 2.5V Supply

($VDD1=2.5V \pm 10\%$, $VDD2=2.5V \pm 10\%$, $T_a=-55^\circ C$ to $125^\circ C$. Unless otherwise noted, Typical values are at $VDD1 = 2.5V$, $VDD2 = 2.5V$, $T_a = 25^\circ C$)

Parameters	Symbol	Min	Typ	Max	Unit	Comments
Data Rate	DR	0		150	Mbps	
Minimum Pulse Width	PW			5.0	ns	
Propagation Delay	t_{PLH}	2.5	9.0	15	ns	See Figure 5.7 , $C_L = 15pF$
	t_{PHL}	2.5	9.3	15	ns	See Figure 5.7 , $C_L = 15pF$
Pulse Width Distortion $ t_{PHL} - t_{PLH} $	PWD			5.0	ns	See Figure 5.7 , $C_L = 15pF$
Rising Time	t_r			5.0	ns	See Figure 5.7 , $C_L = 15pF$
Falling Time	t_f			5.0	ns	See Figure 5.7 , $C_L = 15pF$
Peak Eye Diagram Jitter	$t_{JIT}(PK)$		350		ps	
Channel-to-Channel Delay Skew	$t_{SK}(c2c)$			2.5	ns	
Part-to-Part Delay Skew	$t_{SK}(p2p)$			5.0	ns	
Disable high to Tri-State	t_{PHZ}		12.2	30	ns	See Figure 5.8 , $C_L = 15pF$, $R_L=1k$

Parameters	Symbol	Min	Typ	Max	Unit	Comments
Enable to Data high Valid	t_{PZH}		17.0	30	ns	See Figure 5.8 , $C_L = 15\text{pF}$, $R_L=1\text{k}$
Disable low to Tri-State	t_{PLZ}		17.2	30	ns	See Figure 5.8 , $C_L = 15\text{pF}$, $R_L=1\text{k}$
Enable to Data low Valid	t_{PZL}		17.8	30	ns	See Figure 5.8 , $C_L = 15\text{pF}$, $R_L=1\text{k}$

5.8. Typical Performance Characteristics

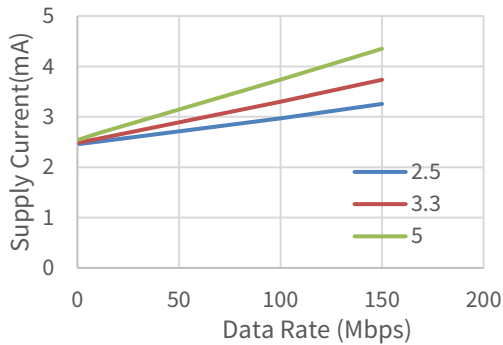

Figure 5.1 NSI8130 VDD1 Supply Current vs Data Rate
Data Rate

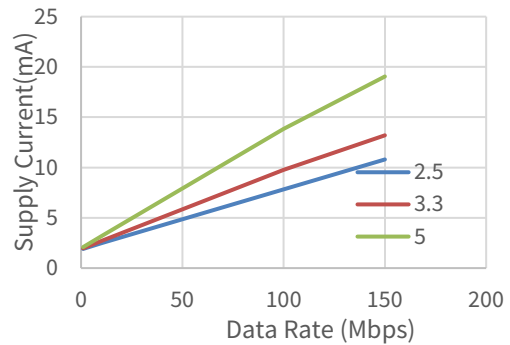

Figure 5.2 NSI8130 VDD2 Supply Current vs Data Rate

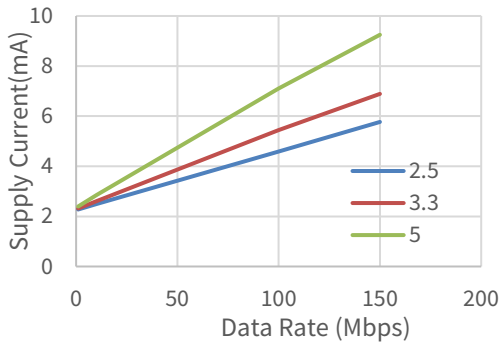

Figure 5.3 NSI8131 VDD1 Supply Current vs Data Rate
vs Data Rate

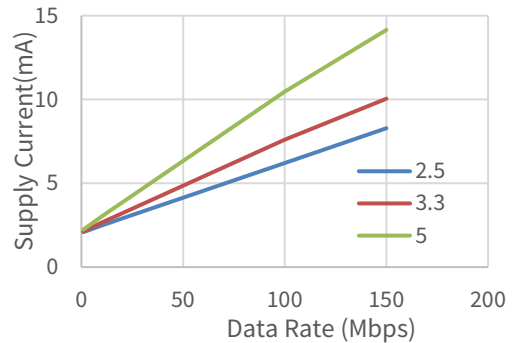

Figure 5.4 NSI8131 VDD2 Supply Current vs Data Rate

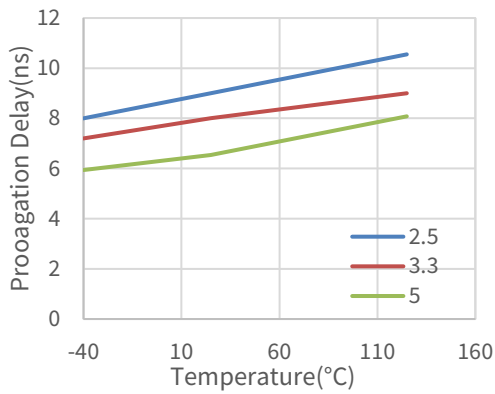

Figure 5.5 Rising Edge Propagation Delay Vs Temp Vs Temp

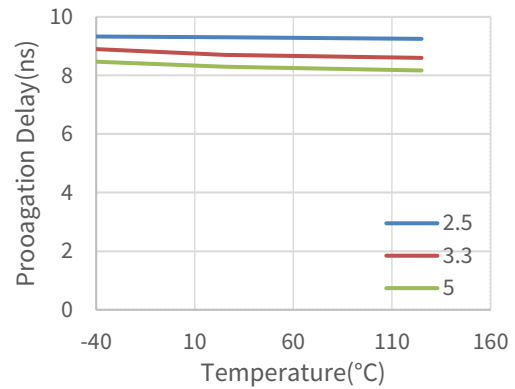
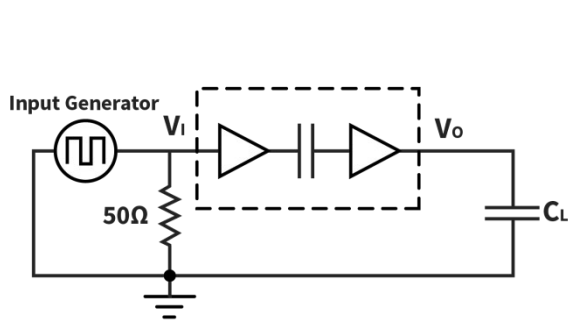

Figure 5.6 Falling Edge Propagation Delay Vs Temp Vs Temp

5.9. Parameter Measurement Information



(1) Input Generator Characteristics : PRR ≤ 50kHz, tr ≤ 3ns, tf ≤ 3ns, Duty cycle = 50%, Zo = 50 Ω.

Figure 5.7 Switching Characteristics Test Circuit and Waveform

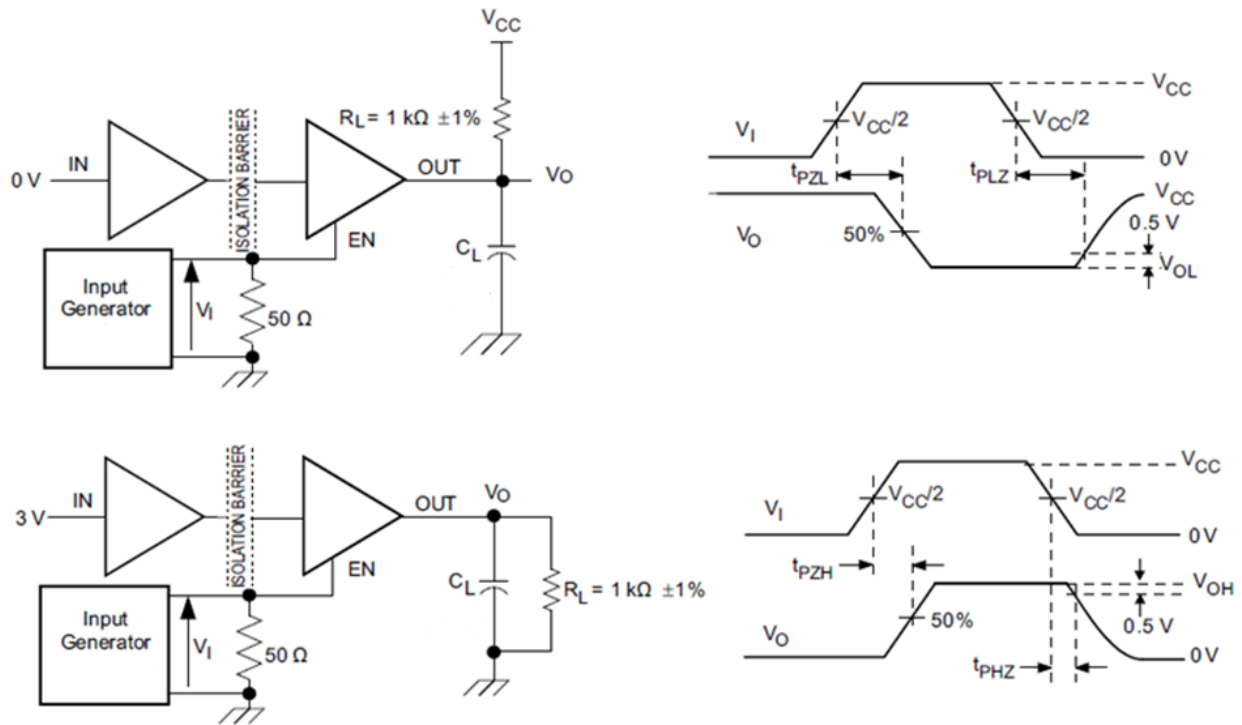

Figure 5.8 Enable/Disable Propagation Delay Time Test Circuit and Waveform

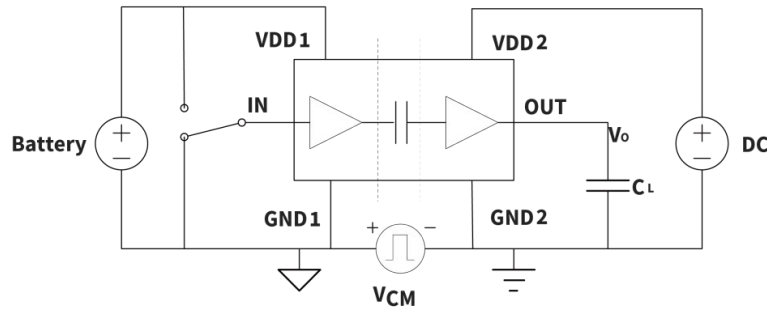

Figure 5.9 Common-Mode Transient Immunity Test Circuit

6. high voltage Feature Description

6.1. Insulation and Safety Related Specifications

Parameters	Symbol	Value				Unit	Comments
		SOP16 (300mil)	SOP16 (600mil)	SSOP16	SOP16 (150mil)		
Minimum External Clearance	CLR	8	15	3.9	4	mm	IEC 60664-1:2007
Minimum External Creepage	CPG	8	15	3.9	4	mm	IEC 60664-1:2007

Parameters	Symbol	Value				Unit	Comments
		SOP16 (300mil)	SOP16 (600mil)	SSOP16	SOP16 (150mil)		
Distance Through Insulation	DTI	28				µm	Distance through insulation
Tracking Resistance (Comparative Tracking Index)	CTI	>600	>600	>600	>600	V	DIN EN 60112 (VDE 0303-11); IEC 60112
Material Group		I	I	I	I		IEC 60664-1

Description	Test Condition	Value			
		SOP16 (300mil)	SOP16 (600mil)	SSOP16	SOP16 (150mil)
Overvoltage Category per IEC60664-1	For Rated Mains Voltage ≤ 150Vrms	I to IV	I to IV	I to IV	I to IV
	For Rated Mains Voltage ≤ 300Vrms	I to IV	I to IV	I to III	I to III
	For Rated Mains Voltage ≤ 600Vrms	I to IV	I to IV	I to II	I to II
	For Rated Mains Voltage ≤ 1000Vrms	I to III	I to IV	I	I to II
Climatic Classification		40/125/21			
Pollution Degree per DIN VDE 0110		2			

6.2. Insulation Characteristics

Description	Test Condition	Symbol	Value				Unit
			SOP16 (300mil)	SOP16 (600mil)	SSOP16	SOP16 (150mil)	
Maximum repetitive isolation voltage		V _{IORM}	2121	2121	565	565	V _{PEAK}
Maximum working isolation voltage	AC Voltage	V _{IOWM}	1500	1500	400	400	V _{RMS}
	DC Voltage		2121	2121	565	565	V _{DC}
Apparent Charge	Method a, after Input/output safety test subgroup 2/3,	q _{pd}	<5	<5	\	\	pC

Description	Test Condition	Symbol	Value				Unit
			SOP16 (300mil)	SOP16 (600mil)	SSOP16	SOP16 (150mil)	
	$V_{ini}=V_{IOTM}$, $t_{ini} = 60\text{ s}$, $V_{pd(m)}=1.2*V_{IORM}$, $t_m=10\text{s}$.						pC
	Method a, after environmental tests subgroup 1, $V_{ini}=V_{IOTM}$, $t_{ini}=60\text{s}$, $V_{pd(m)}=1.6*V_{IORM}$, $t_m=10\text{s}$						
	Method b, routine test (100% production) and preconditioning (type test); $V_{ini}=1.2*V_{IOTM}$, $t_{ini}=1\text{s}$ $V_{pd(m)}=1.875*V_{IORM}$, $t_m=1\text{s}$ (method b1) or $V_{pd(m)}=V_{ini}$, $t_m=t_{ini}$ (method b2)						
Apparent Charge	Method a, after Input/output safety test subgroup 2/3, $V_{ini}=V_{IOTM}$, $t_{ini} = 60\text{ s}$, $V_{pd(m)}=1.2*V_{IORM}$, $t_m=10\text{s}$.	q_{pd}	\	\	<5	<5	pC
	Method a, after environmental tests subgroup 1, $V_{ini}=V_{IOTM}$, $t_{ini}=60\text{s}$, $V_{pd(m)}=1.3*V_{IORM}$, $t_m=10\text{s}$						pC
	Method b, routine test (100% production) and preconditioning (type test); $V_{ini}=1.2*V_{IOTM}$, $t_{ini}=1\text{s}$ $V_{pd(m)}=1.5*V_{IORM}$, $t_m=1\text{s}$ (method b1) or $V_{pd(m)}=V_{ini}$, $t_m=t_{ini}$ (method b2)						pC
Maximum transient isolation voltage	$t = 60\text{ sec}$	V_{IOTM}	8000	12000	5000	5000	V_{PEAK}
Maximum impulse voltage	Tested in air, 1.2/50-us waveform per IEC62368-1	V_{IMP}	6250	8000	5384	5384	V_{PEAK}

Description	Test Condition	Symbol	Value				Unit
			SOP16 (300mil)	SOP16 (600mil)	SSOP16	SOP16 (150mil)	
Maximum Surge Isolation Voltage	Test method per IEC62368-1, 1.2/50us waveform, $V_{IOSM} \geq V_{IMP} \times 1.3$	V_{IOSM}	10000	12800	7000	7000	V_{PEAK}
Isolation resistance	$V_{IO} = 500V, T_{amb} = 25^{\circ}C$	R_{IO}	$>10^{12}$	$>10^{12}$	$>10^{12}$	$>10^{12}$	Ω
	$V_{IO} = 500V, 100^{\circ}C \leq T_{amb} \leq 125^{\circ}C$	R_{IO}	$>10^{11}$	$>10^{11}$	$>10^{11}$	$>10^{11}$	Ω
	$V_{IO} = 500V, T_{amb} = T_s$	R_{IO}	$>10^9$	$>10^9$	$>10^9$	$>10^9$	Ω
Isolation capacitance	$f = 1MHz$	C_{IO}	0.8	0.8	0.8	0.8	pF
UL1577							
Insulation voltage per UL	$V_{TEST} = V_{ISO}, t = 60 s$ (qualification), $V_{TEST} = 1.2 \times V_{ISO}, t = 1 s$ (100% production test)	V_{ISO}	5000	8500	3000	3750	V_{RMS}

6.3. Safety-Limiting Values

Reinforced isolation safety-limiting values as outlined in VDE-0884-11 of NSI823x-DSWxR (SOP16(300mil)/SOP16(600mil))

Description	Test Condition	Value	Unit
Safety Supply Power	$R_{\theta JA} = 78.9^{\circ}C/W^1), T_J = 150^{\circ}C, T_A = 25^{\circ}C$	1584	mW
Safety Supply Current	$R_{\theta JA} = 78.9^{\circ}C/W^1), V_I = 5V, T_J = 150^{\circ}C, T_A = 25^{\circ}C$	316.8	mA
Safety Temperature ²⁾		150	$^{\circ}C$

- 1) Calculate with the junction-to-air thermal resistance, $R_{\theta JA}$, of SOP16(300mil)/SOP16(600mil) package ([Thermal Information Table](#)) which is that of a device installed on a low effective thermal conductivity test board (1s) according to JESD51-3.
- 2) The maximum safety temperature has the same value as the maximum junction temperature (T_J) specified for the device.

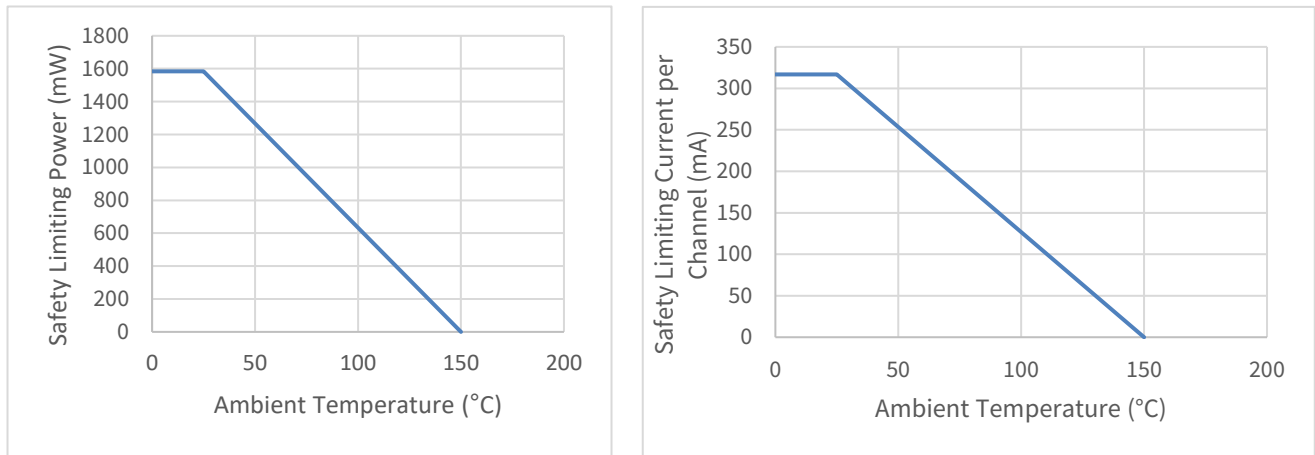

Figure 6.1 NSI823xW Thermal Derating Curve, Dependence of Safety Limiting Values with Case Temperature per DIN VDE V 0884-11

Basic isolation safety-limiting values as outlined in VDE-0884-11 of NSI823x-DSSR (SSOP16)

Description	Test Condition	Value	Unit
Safety Supply Power	$R_{\theta JA} = 140^{\circ}\text{C}/\text{W}^{(1)}$, $T_J = 150^{\circ}\text{C}$, $T_A = 25^{\circ}\text{C}$	880	mW
Safety Supply Current	$R_{\theta JA} = 140^{\circ}\text{C}/\text{W}^{(1)}$, $V_I = 5\text{V}$, $T_J = 150^{\circ}\text{C}$, $T_A = 25^{\circ}\text{C}$	176	mA
Safety Temperature ²⁾		150	°C

- 1) Calculate with the junction-to-air thermal resistance, $R_{\theta JA}$, of SSOP16 package ([Thermal Information Table](#)) which is that of a device installed on a low effective thermal conductivity test board (1s) according to JESD51-3.
- 2) The maximum safety temperature has the same value as the maximum junction temperature (T_J) specified for the device.

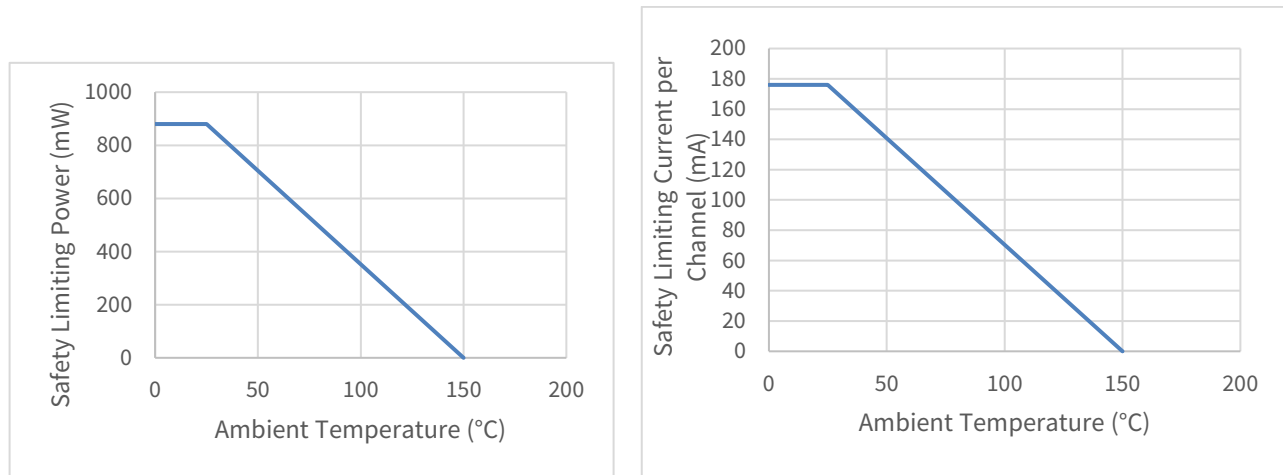

Figure 6.2 NSI823xS Thermal derating Curve, Dependence of Safety Limiting Values with Case Temperature per DIN VDE V 0884-11

Basic isolation safety-limiting values as outlined in VDE-0884-11 of NSI823x-DSPNR (SOP16)

Description	Test Condition	Value	Unit
Safety Supply Power	$R_{\theta JA} = 78.9^{\circ}\text{C}/\text{W}^{(1)}$, $T_J = 150^{\circ}\text{C}$, $T_A = 25^{\circ}\text{C}$	1584	mW
Safety Supply Current	$R_{\theta JA} = 78.9^{\circ}\text{C}/\text{W}^{(1)}$, $V_I = 5\text{V}$, $T_J = 150^{\circ}\text{C}$, $T_A = 25^{\circ}\text{C}$	316	mA
Safety Temperature ²⁾		150	$^{\circ}\text{C}$

- 1) Calculate with the junction-to-air thermal resistance, $R_{\theta JA}$, of SOP16(150mil) package ([Thermal Information Table](#)) which is that of a device installed on a low effective thermal conductivity test board (1s) according to JESD51-3.
- 2) The maximum safety temperature has the same value as the maximum junction temperature (T_J) specified for the device.

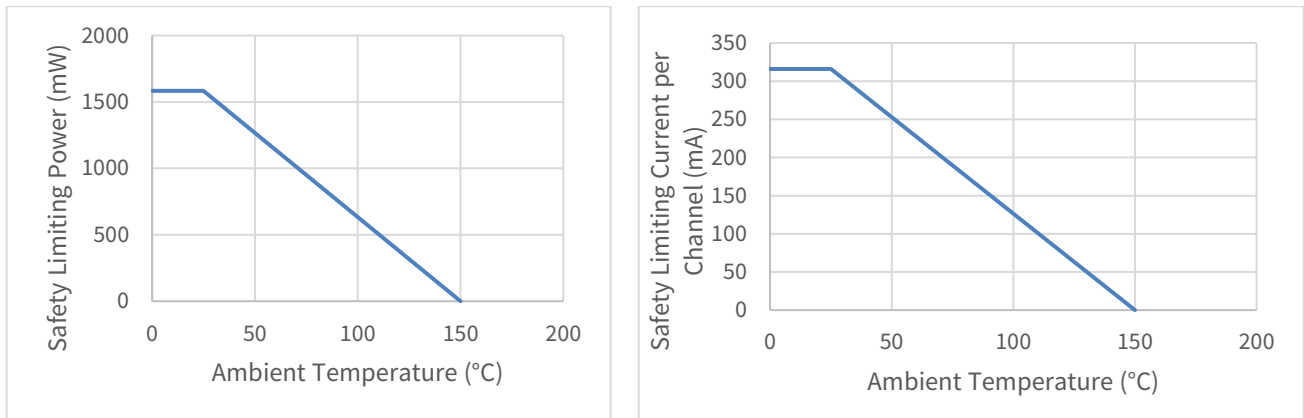

Figure 6.2 NSI823xN Thermal derating Curve, Dependence of Safety Limiting Values with Case Temperature per DIN VDE V 0884-11

6.4. Regulatory Information

The NSI823xWx-DSWR are approved or pending approval by the organizations listed in table.

CUL		VDE	CQC	TUV
UL 1577 Component Recognition Program	Approved under CSA Component Acceptance Notice 5A	DIN EN IEC 60747-17 (VDE 0884-17)	Certified according to GB4943.1-2022	Certified According to EN IEC 62368-1
Single Protection, 5000V _{rms} Isolation voltage	Single Protection, 5000V _{rms} Isolation voltage	Reinforced Insulation $V_{IORM}=2121\text{Vpeak}$ $V_{IOTM}=8000\text{Vpeak}$ $V_{IOSM}=10000\text{Vpeak}$	Reinforced insulation	5000Vrms for 1min
E500602	E500602	File (40052820)	CQC20001264939	R50574061

The NSI823xWx-DSWWR are approved or pending approval by the organizations listed in table.

CUL		VDE	CQC	TUV
UL 1577 Component Recognition Program	Approved under CSA Component Acceptance Notice 5A	DIN EN IEC 60747-17 (VDE 0884-17)	Certified according to GB4943.1-2022	Certified According to EN IEC 62368-1
Single Protection, 8500V _{rms} Isolation voltage	Single Protection, 8500V _{rms} Isolation voltage	Reinforced Insulation V _{IORM} =2121V _{peak} V _{IOTM} =12000V _{peak} V _{IOSM} =12800V _{peak}	Reinforced insulation	5000Vrms for 1min
E500602	E500602	File (40052820)	CQC23001379406	R50574061

The NSI823xSx-DSSR are approved or pending approval by the organizations listed in table.

CUL		VDE	CQC	TUV
UL 1577 Component Recognition Program	Approved under CSA Component Acceptance Notice 5A	DIN EN IEC 60747-17 (VDE 0884-17)	Certified according to GB4943.1-2022	Certified According to EN IEC 62368-1
Single Protection, 3000V _{rms} Isolation voltage	Single Protection, 3000V _{rms} Isolation voltage	Basic Insulation V _{IORM} =565V _{peak} V _{IOTM} =5000V _{peak} V _{IOSM} =7000V _{peak}	Basic insulation	5000Vrms for 1min
E500602	E500602	File (40057024)	CQC23001391258	R50574061

The NSI823xNx--DSPNR are approved or pending approval by the organizations listed in table.

CUL		VDE	CQC	TUV
UL 1577 Component Recognition Program	Approved under CSA Component Acceptance Notice 5A	DIN EN IEC 60747-17 (VDE 0884-17)	Certified according to GB4943.1-2022	Certified According to EN IEC 62368-1
Single Protection, 3750V _{rms} Isolation voltage	Single Protection, 3750V _{rms} Isolation voltage	Basic Insulation V _{IORM} =565V _{peak} V _{IOTM} =5000V _{peak} V _{IOSM} =7000V _{peak}	Basic insulation	3000Vrms for 1min
E500602	E500602	File (40057024)	CQC21001289931	R50574061

7. Function Description

7.1. Overview

The NSI823x is a Triple-channel digital isolator based on a capacitive isolation barrier technique. The digital signal is modulated with RF carrier generated by the internal oscillator at the Transmitter side. Then it is transferred through the capacitive isolation barrier and demodulated at the Receiver side.

The NSI823x devices are high reliability Triple-channel digital isolator. The NSI823x device is safety certified by UL1577 support $5kV_{rms}$ insulation withstand voltages, while providing high electromagnetic immunity and low emissions at low power consumption. The data rate of the NSI823x is up to 150Mbps, and the common-mode transient immunity (CMTI) is up to 250kV/us. The NSI823x device provides digital channel direction configuration and the default output level configuration when the input power is lost. Wide supply voltage of the NSI823x device support to connect with most digital interface directly, easy to do the level shift. High system level EMC performance enhance reliability and stability of use.

The NSI823x has a default output status when VDDIN is unready and VDDOUT is ready as shown in Table 7.1, which helps for diagnosis when power is missing at the transmitter side. The output B follows the same status with the input A after powering up.

Table 7.1 Output status vs. power status

<i>Input¹</i>	<i>EN_x²</i>	<i>VDD1 status</i>	<i>VDD2 status</i>	<i>Output</i>	<i>Comment</i>
H	H or NC	Ready	Ready	H	Normal operation.
L	H or NC	Ready	Ready	L	
X	L	Ready	Ready	Z	Output Disabled, the output is high impedance
X	H or NC	Unready	Ready	L(NSI823xx0) H(NSI823xx1)	The output follows the same status with the input after input side VDD is powered on.
X	L	Unready	Ready	Z	Output Disabled, the output is high impedance
X	X	Ready	Unready	Undetermined	The output follows the same status with the input after output side VDD2 is powered on.

Note: H=Logic high; L=Logic low; X=Logic low or logic high
VDD1 is input side power; VDD2 is outside power.

(1) There is a protection diode between the input and the VDDIN. When the VDDIN is floating, the strong drive signal through the input pin will put the VDDIN in an indeterminate state.

(2) The EN_x is output side enable.

7.2. OOK Modulation

NSI823x is based on a capacitive isolation barrier technique and the digital signal is modulated with RF carrier generated by the internal oscillator at the transmitter side, as shown in Figure 7.1 to Figure 7.2, then it is transferred through the capacitive isolation barrier and demodulated at the receiver side. The modulation uses OOK modulation technique with key benefits of high noise immunity and low radiation EMI.

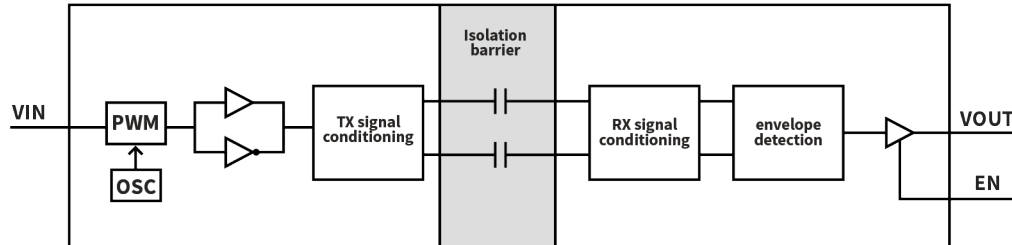

Figure 7.1 Single Channel Function Block Diagram

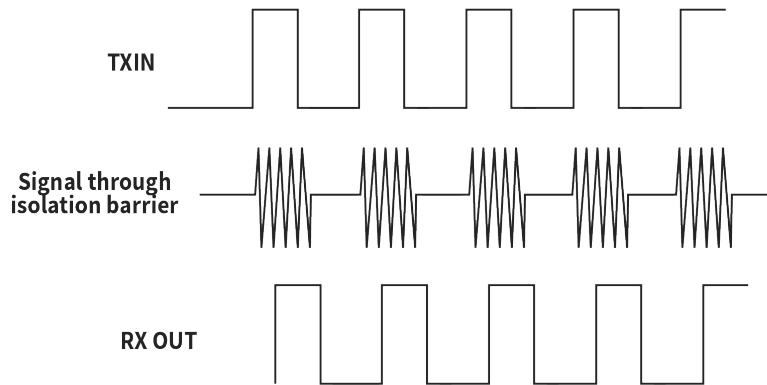

Figure 7.2 OOK Modulation

8. Application Note

8.1. Typical Application Circuit

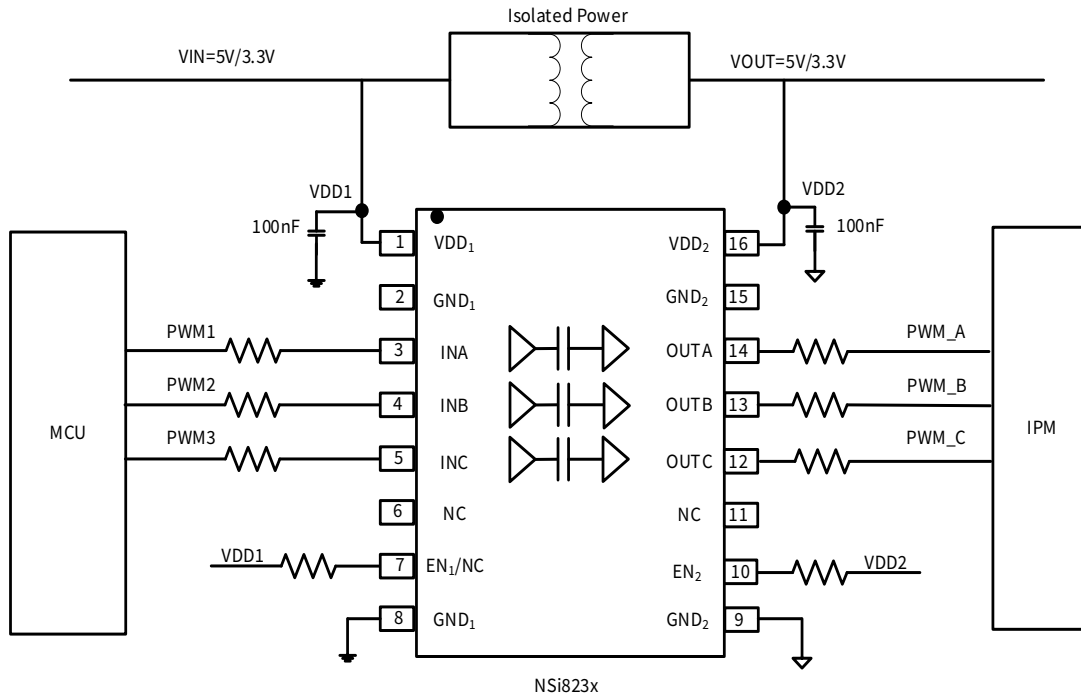

Figure 8.1 Typical PWM isolation circuit for IPM

8.2. PCB Layout

The NSI823x requires a 0.1 μF bypass capacitor between VDD1 and GND1, VDD2 and GND2. The capacitor should be placed as close as possible to the package. Figure 8.2 to Figure 8.3 show the recommended PCB layout, make sure the space under the chip should keep free from planes, traces, pads and via. To enhance the robustness of a design, the user may also include resistors (50–300 Ω) in series with the inputs and outputs if the system is excessively noisy. The series resistors also improve the system reliability such as latch-up immunity.

The typical output impedance of an isolator driver channel is approximately 50 Ω , $\pm 40\%$. When driving loads where transmission line effects will be a factor, output pins should be appropriately terminated with controlled impedance PCB traces.

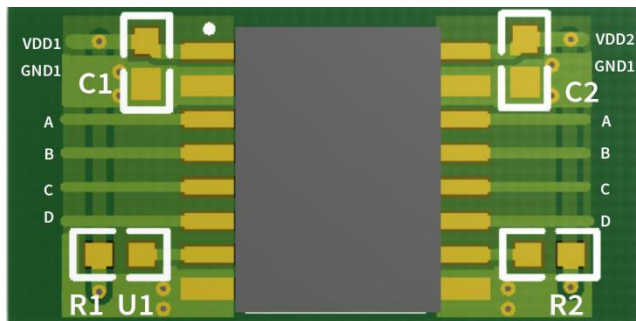

Figure8.2 Recommended PCB Layout — Top Layer

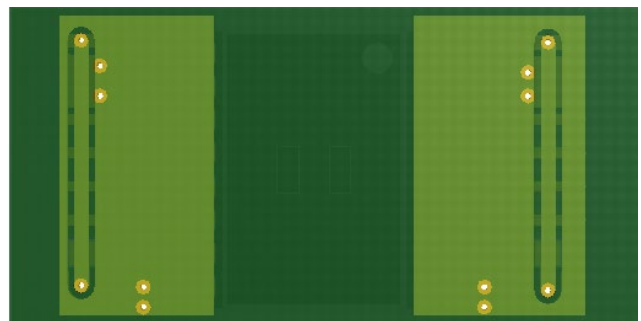

Figure8.3 Recommended PCB Layout — Bottom Layer

8.3. High Speed Performance

Figure 8.4 shows the eye diagram of NSI823x at 50Mbps data rate output. The result shows a typical measurement on NSI823x with low jitter and wide open eye characteristics.

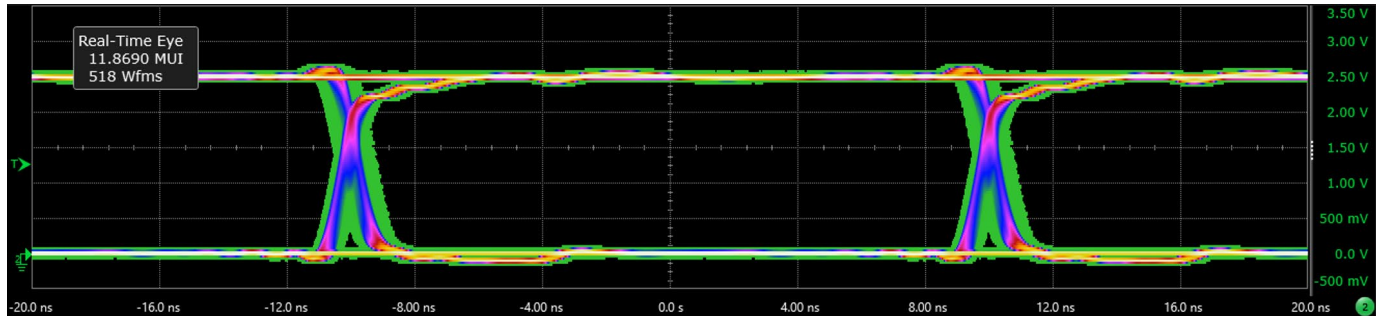

Figure 8.4 Eye Diagram at 50Mbps PRBS $2^{16}-1$, 2.5V and 25°C

8.4. Typical Supply Current Equations

The typical supply current of NSI823x can be calculated using below equations. I_{DD1} and I_{DD2} are typical supply currents measured in mA, f is data rate measured in Mbps, C_L is the capacitive load measured in pF

NSI8230:

$$I_{DD1} = 0.19 * a1 + 1.45 * b1 + 0.82 * c1.$$

$$I_{DD2} = 1.36 + VDD2 * f * C_L * c1 * 10^{-9}$$

When $a1$ is the channel number of low input at side 1, $b1$ is the channel number of high input at side 1, $c1$ is the channel number of switch signal input at side 1.

NSI8231:

$$I_{DD1} = 0.87 + 1.26 * b1 + 0.63 * c1 + VDD1 * f * C_L * c2 * 10^{-9}$$

$$I_{DD2} = 0.87 + 1.26 * b2 + 0.63 * c2 + VDD2 * f * C_L * c1 * 10^{-9}$$

When $b1$ is the channel number of high input at side 1, $c1$ is the channel number of switch signal input at side 1, $b2$ is the channel number of high input at side 2, $c2$ is the channel number of switch signal input at side 2.

9. Package Information

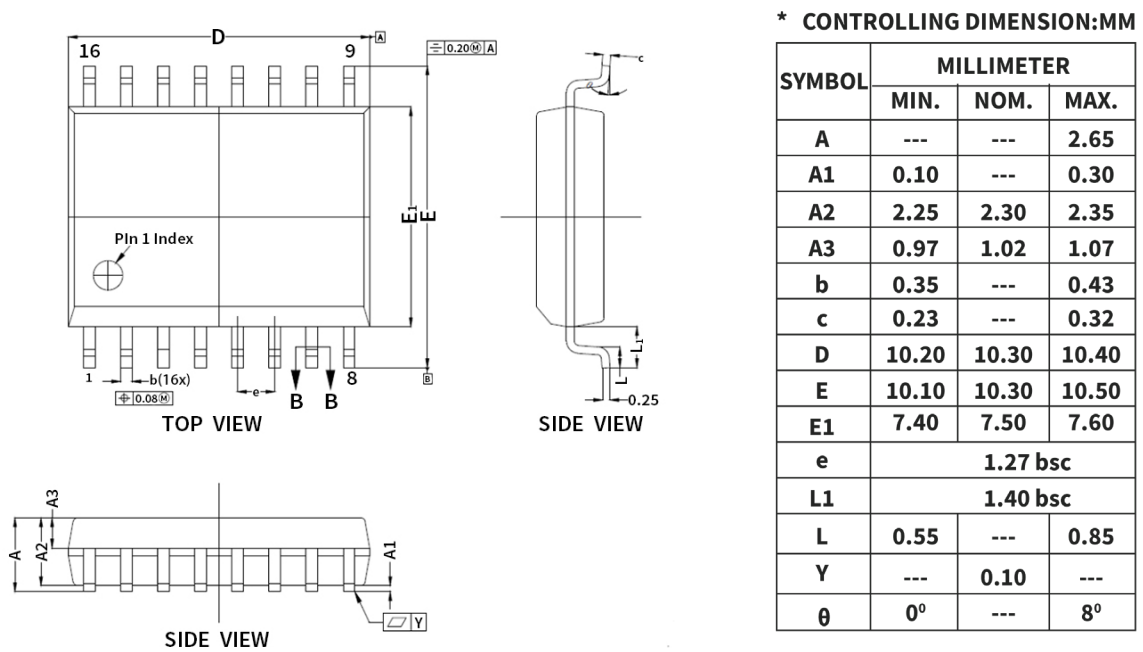

Figure 9.1 SOP16(300mil)/SOW16 Package Shape and Dimension in millimeters

NOTE: This dimension does not include mold flash, protrusions, or gate burrs. Mold flash, protrusions, or gate burrs shall not exceed 0.15 mm, per side.

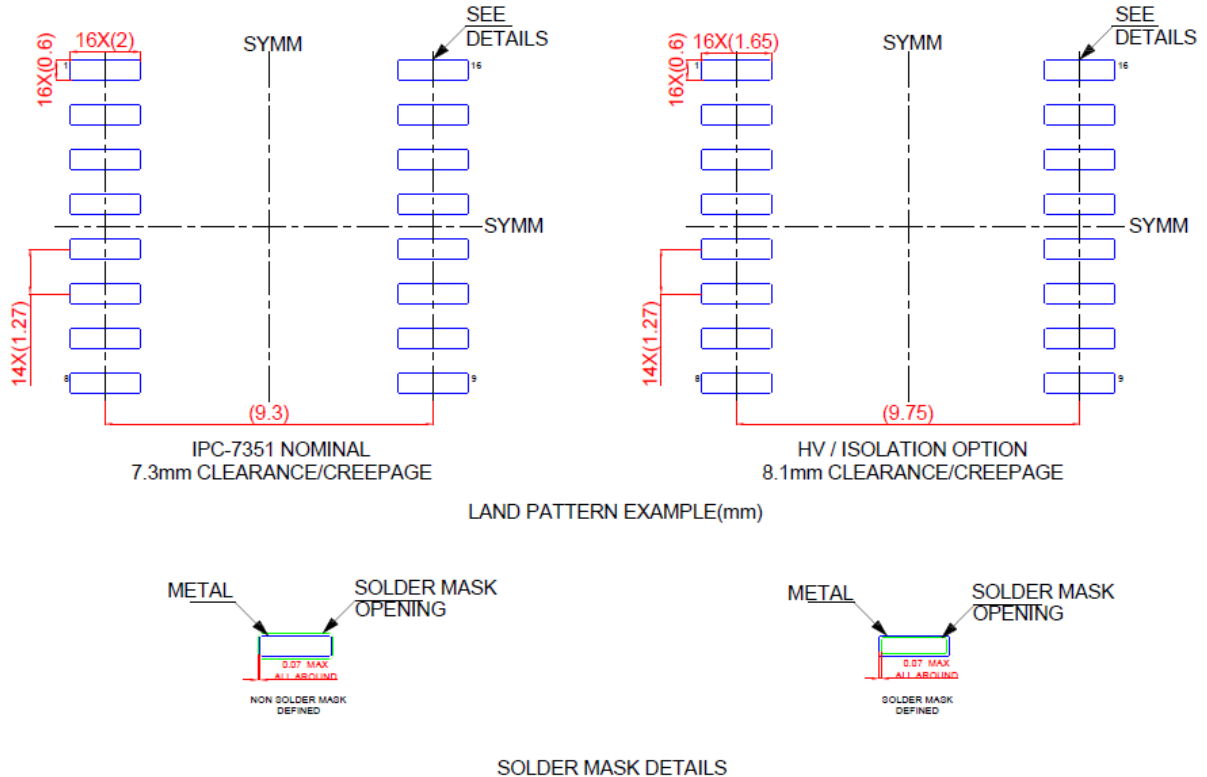
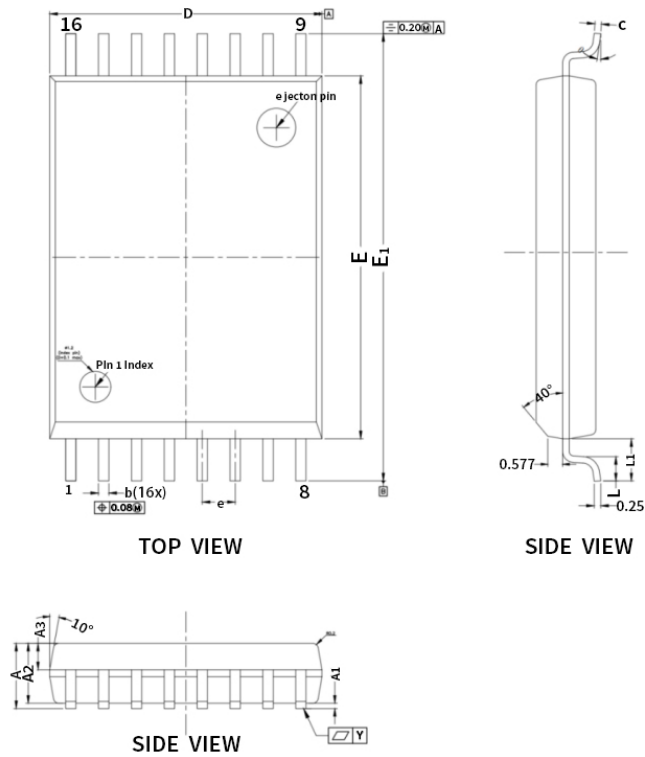

Figure 9.2 SOP16(300mil)/SOW16 Package Board Layout Example



* CONTROLLING DIMENSION:MM

SYMBOL	MILLIMETER		
	MIN.	NOM.	MAX.
A	---	---	2.65
A1	0.10	---	0.30
A2	2.25	2.30	2.35
A3	0.97	1.02	1.07
b	0.35	---	0.43
c	0.23	---	0.32
D	10.42	10.52	10.62
E	13.9	14.0	14.1
E1	17.1	---	17.4
e	1.27 bsc		
L1	1.625 bsc		
L	0.6	---	1.1
Y	---	0.10	---
θ	0°	---	8°

NOTES
 1.0 COPWNRITY APPLIES TO LEADS, CORNER LEADS AND DIE ATTACH PAD.

Figure 9.3 SOP16(600mil)/SOWW16 Package Shape and Dimension in millimeters

NOTE: This dimension does not include mold flash, protrusions, or gate burrs. Mold flash, protrusions, or gate burrs shall not exceed 0.15 mm, per side.

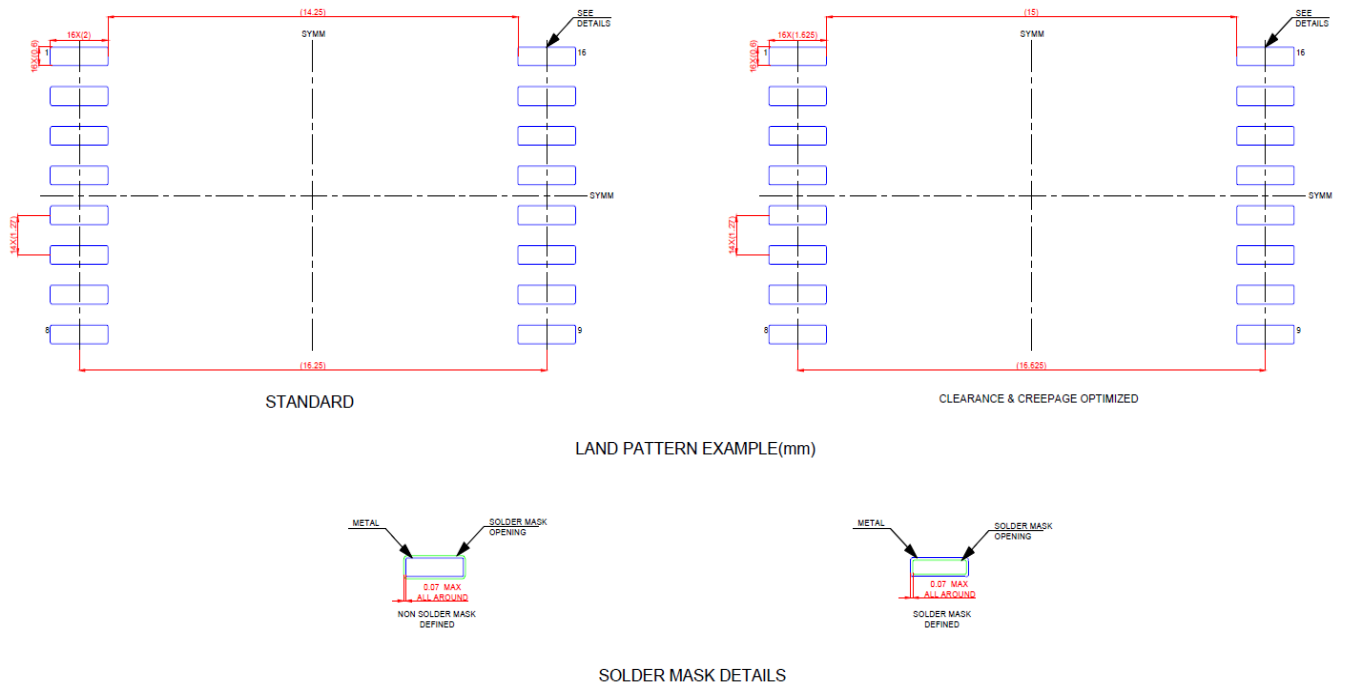
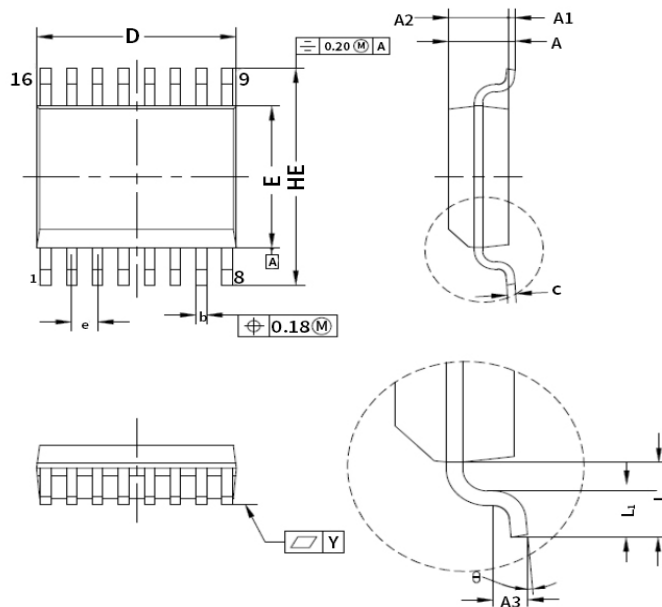

Figure 9.4 SOP16(600mil)/SOWW16 Package Board Layout Example



* CONTROLLING DIMENSION:MM

SYMBOL	MILLIMETER			INCH		
	MIN.	NOM.	MAX.	MIN.	NOM.	MAX.
A	---	---	1.73	---	---	0.068
A1	0.10	---	0.25	0.004	---	0.010
A2	1.40	---	1.55	0.055	---	0.061
b	0.20	---	0.31	0.008	---	0.012
c	0.18	---	0.25	0.007	---	0.010
D	4.80	---	5.00	0.189	---	0.197
E	3.80	---	4.00	0.150	---	0.157
HE	5.80	---	6.20	0.228	---	0.244
e	0.635 bsc			0.025 bsc		
L	1.00 bsc			0.039 bsc		
L1	0.41	---	0.89	0.016	---	0.035
Y	---	0.09	---	---	0.004	---
A3	---	0.25	---	---	0.010	---
θ	0°	---	8°	0°	---	8°

Figure 9.5 SSOP16 Package Shape and Dimension in millimeters

NOTE: This dimension does not include mold flash, protrusions, or gate burrs. Mold flash, protrusions, or gate burrs shall not exceed 0.15 mm, per side.

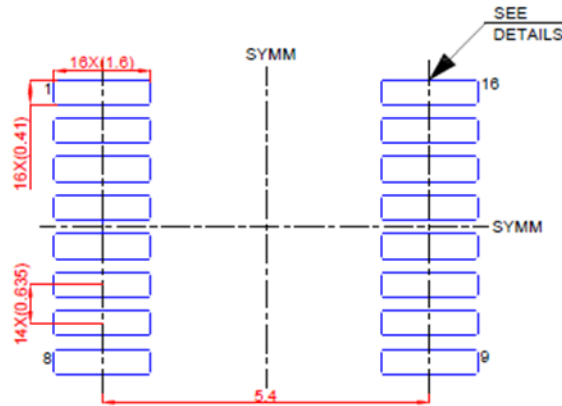

LAND PATTERN EXAMPLE(mm)

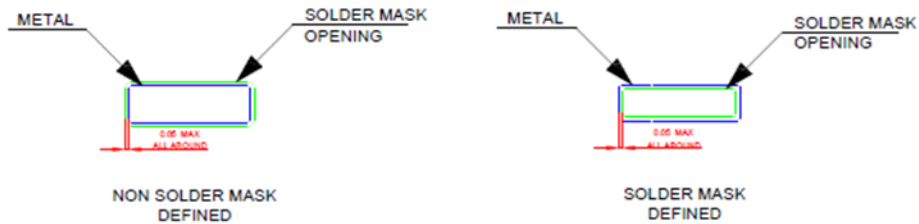

Figure 9.6 SSOP16 Package Board Layout Example

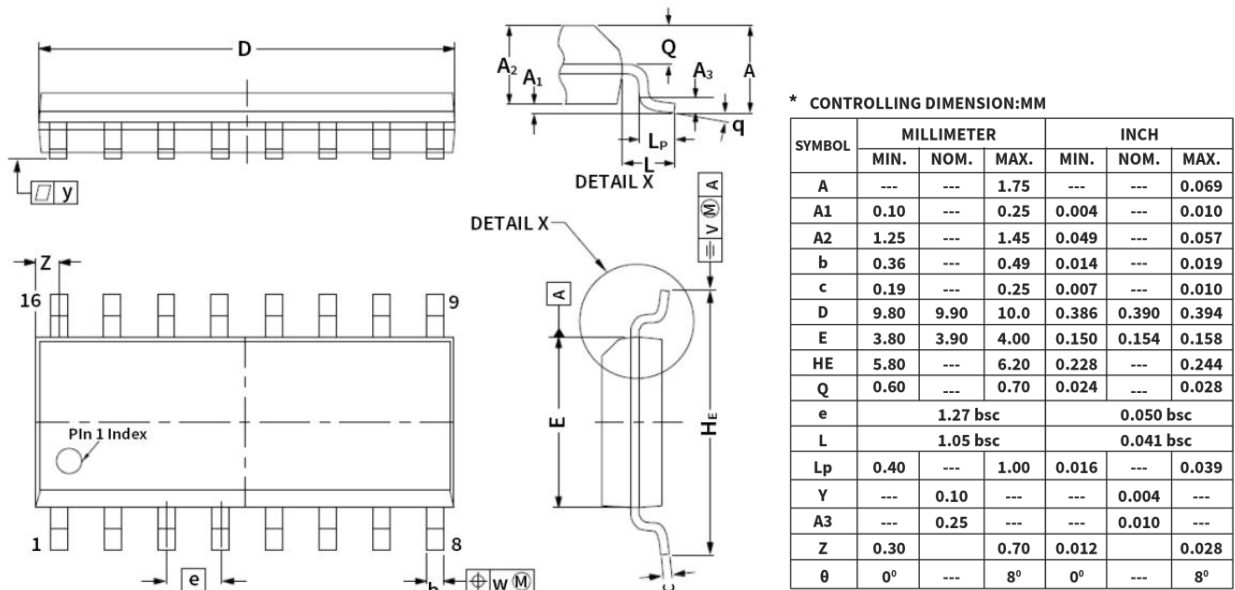

Figure 9.7 SOP16(150mil) Package Shape and Dimension in millimeters

NOTE: This dimension does not include mold flash, protrusions, or gate burrs. Mold flash, protrusions, or gate burrs shall not exceed 0.15 mm, per side.

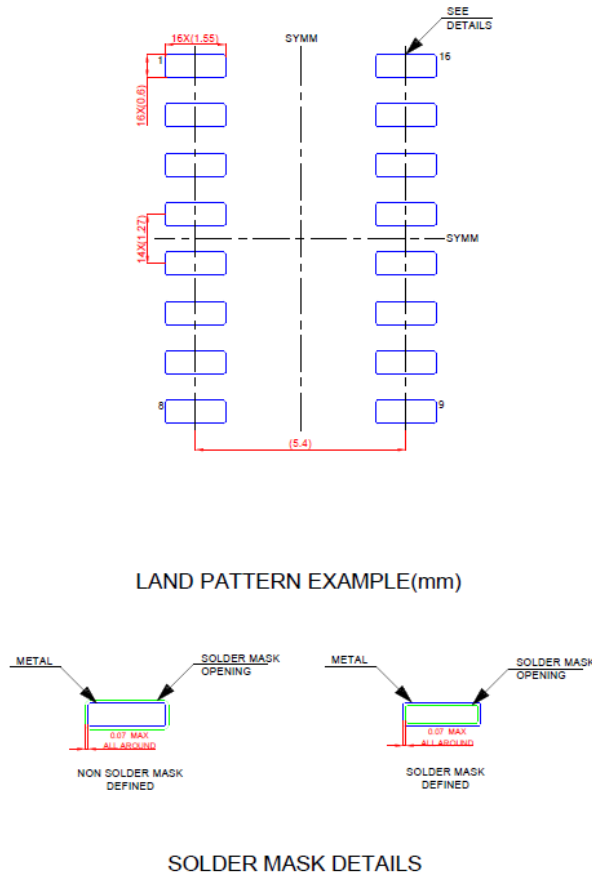

Figure 9.8 SOP16(150mil) Package Board Layout Example

10. Order Information

Part Number	Isolation Rating (kV)	Number of side 1 inputs	Number of side 2 inputs	Max Data Rate (Mbps)	Default Output State	Temperature	MSL	Package Type	Package Drawing	SPQ
NSI8230W0-DSWR	5	3	0	150	Low	-55 to 125°C	2	SOP16 (300mil)	SOW16	1000
NSI8230W1-DSWR	5	3	0	150	High	-55 to 125°C	2	SOP16 (300mil)	SOW16	1000
NSI8231W0-DSWR	5	2	1	150	Low	-55 to 125°C	2	SOP16 (300mil)	SOW16	1000
NSI8231W1-DSWR	5	2	1	150	High	-55 to 125°C	2	SOP16 (300mil)	SOW16	1000
NSI8230W0-DSWWR	8	3	0	150	Low	-55 to 125°C	3	SOP16 (600mil)	SOWW16	1000
NSI8230W1-DSWWR	8	3	0	150	High	-55 to 125°C	3	SOP16 (600mil)	SOWW16	1000
NSI8231W0-DSWWR	8	2	1	150	Low	-55 to 125°C	3	SOP16 (600mil)	SOWW16	1000
NSI8231W1-DSWWR	8	2	1	150	High	-55 to 125°C	3	SOP16 (600mil)	SOWW16	1000
NSI8230S0-DSSR	3	3	0	150	Low	-55 to 125°C	1	SSOP16	SSOP16	2500
NSI8230S1-DSSR	3	3	0	150	High	-55 to 125°C	1	SSOP16	SSOP16	2500
NSI8231S0-DSSR	3	2	1	150	Low	-55 to 125°C	1	SSOP16	SSOP16	2500
NSI8231S1-DSSR	3	2	1	150	High	-55 to 125°C	1	SSOP16	SSOP16	2500
NSI8230N0-DSPNR	3	3	0	150	Low	-55 to 125°C	1	SOP16 (150mil)	SOP16	2500
NSI8230N1-DSPNR	3	3	0	150	High	-55 to 125°C	1	SOP16 (150mil)	SOP16	2500
NSI8231N0-DSPNR	3	2	1	150	Low	-55 to 125°C	1	SOP16 (150mil)	SOP16	2500
NSI8231N1-DSPNR	3	2	1	150	High	-55 to 125°C	1	SOP16 (150mil)	SOP16	2500

NOTE: All packages are RoHS-compliant with peak reflow temperatures of 260 °C according to the JEDEC industry standard classifications and peak solder temperatures.

Part Number Rule:

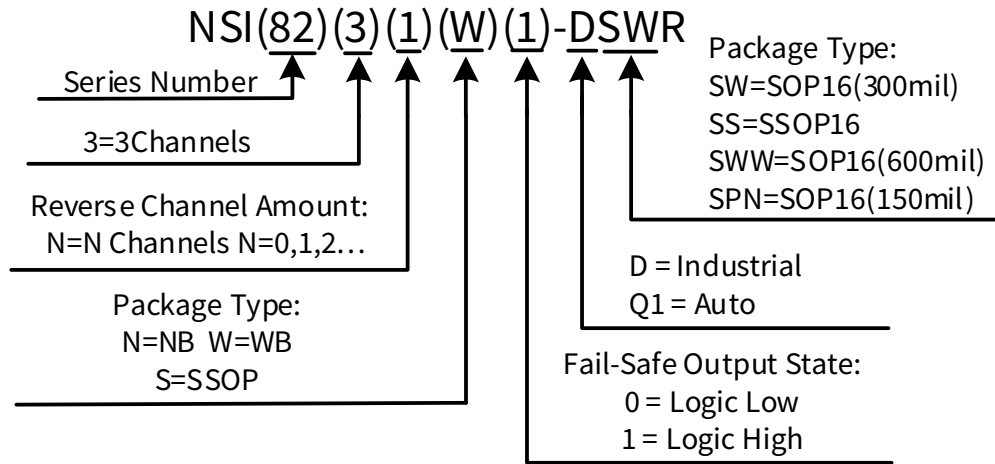

11. Documentation Support

<i>Part Number</i>	<i>Product Folder</i>	<i>Datasheet</i>	<i>Technical Documents</i>	<i>Isolator selection guide</i>
NSI823x	tbd	tbd	tbd	tbd

12. Tape and Reel Information

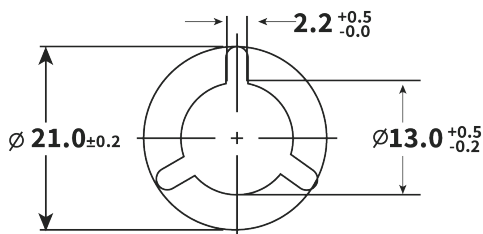
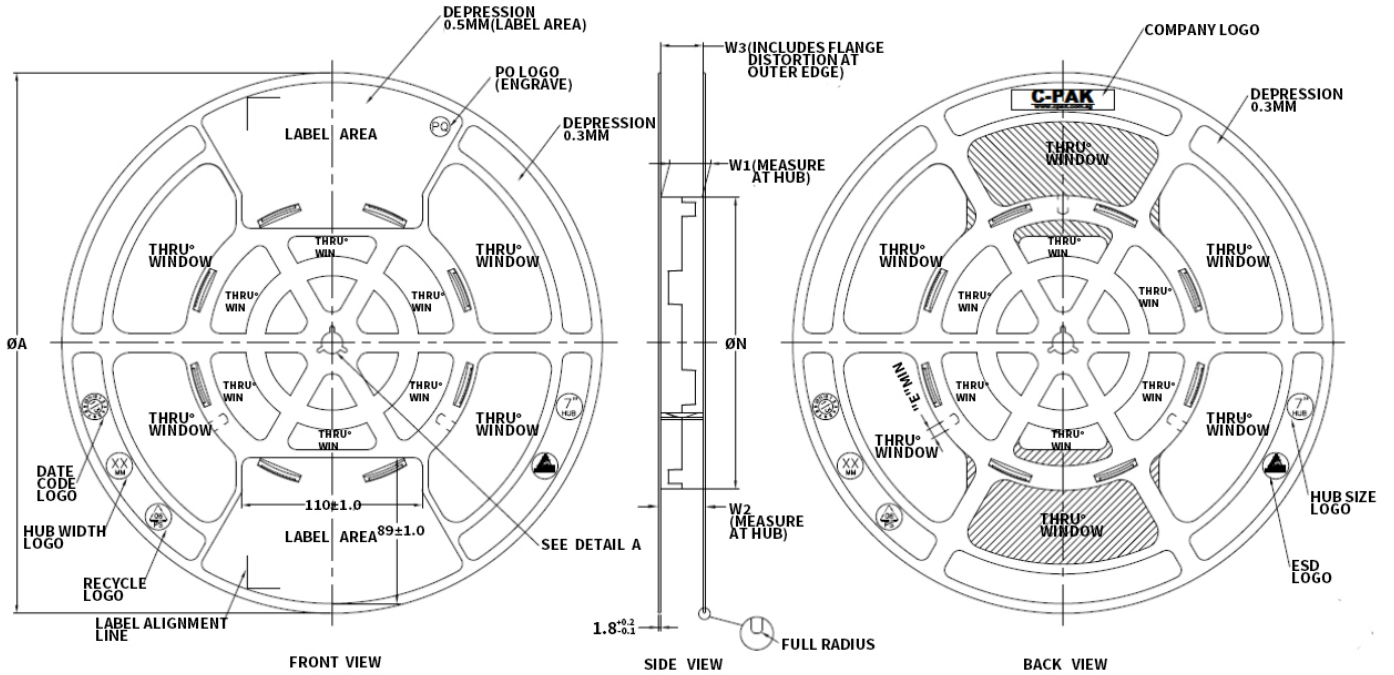

**ARBOR HOLE
DETAIL A
SCALE: 3:1**

PRODUCT SPECIFICATION						
TAPE WIDTH	$\varnothing A$ ± 2.0	$\varnothing N$ ± 2.0	W1	W2 (Max)	W3	E (MIN)
08MM	330	178	$8.4^{+1.5}_{-0.0}$	14.4	SHALL ACCOMMODATE TAPE WIDTH WITHOUT INTERFERENCE	5.5
12MM	330	178	$12.4^{+2.0}_{-0.0}$	18.4		5.5
16MM	330	178	$16.4^{+2.0}_{-0.0}$	22.4		5.5
24MM	330	178	$24.4^{+2.0}_{-0.0}$	30.4		5.5
32MM	330	178	$32.4^{+2.0}_{-0.0}$	38.4		5.5

SURFACE RESISTIVITY			
LEGEND	SR RANGE	TYPE	COLOUR
A	BELOW 10^{12}	ANTISTATIC	ALL TYPES
B	10^5 TO 10^{11}	STATIC DISSIPATIVE	BLACK ONLY
C	10^5 & BELOW 10^5	CONDUCTIVE(GENERIC)	BLACK ONLY
E	10^9 TO 10^{11}	ANTISTATIC(COATED)	ALL TYPES

Figure 12.1 Reel Information (for all packages)

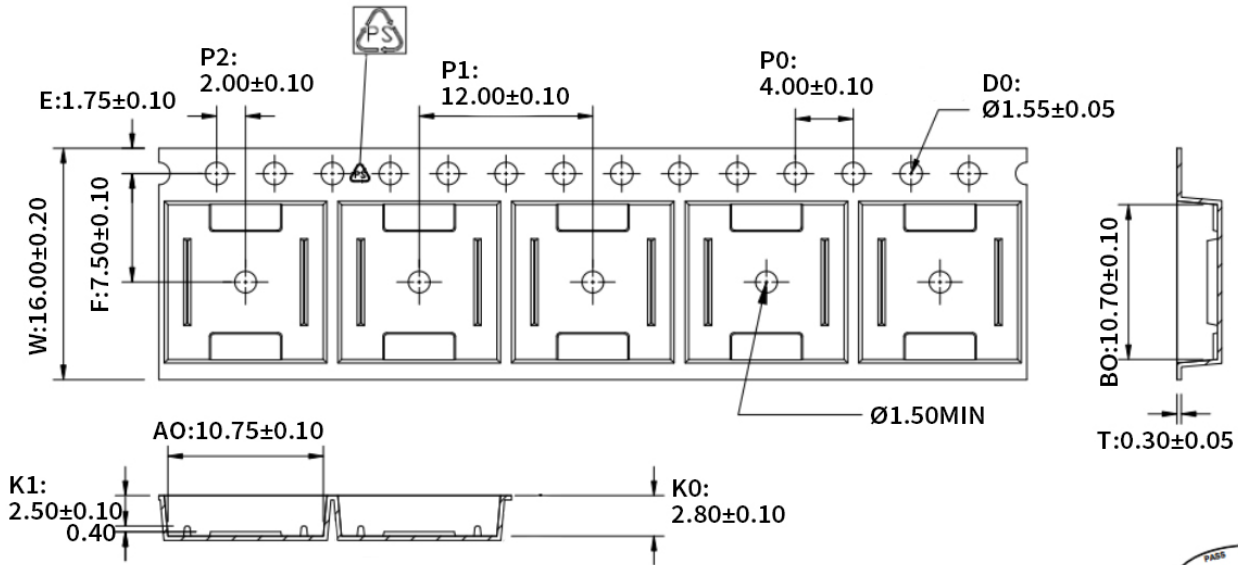

1. 1.10 sprocket hole pitch cumulative tolerance ± 0.20 .
2. Carrier camber is within 1 mm in 250 mm.
3. Material : Black Conductive Polystyrene Alloy.
4. All dimensions meet EIA-481 requirements.
5. Thickness: 0.30 ± 0.05 mm.
6. Packing length per 22" reel: 378 Meters.(Rewind N=122)
7. Component load per 13" reel: 1000 pcs.
8. Surface resistivity: $10^5 \sim 10^{10} \Omega/\square$

W	16.00±0.20
A0	10.75±0.10
B0	10.70±0.10
K0	2.80±0.10
K1	2.50±0.10

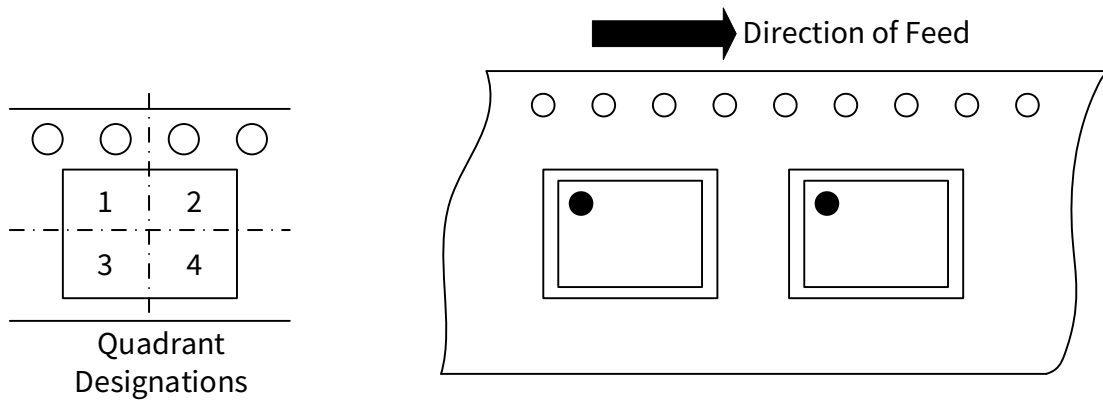

Figure 12.2 Tape Information of SOP16(300mil)

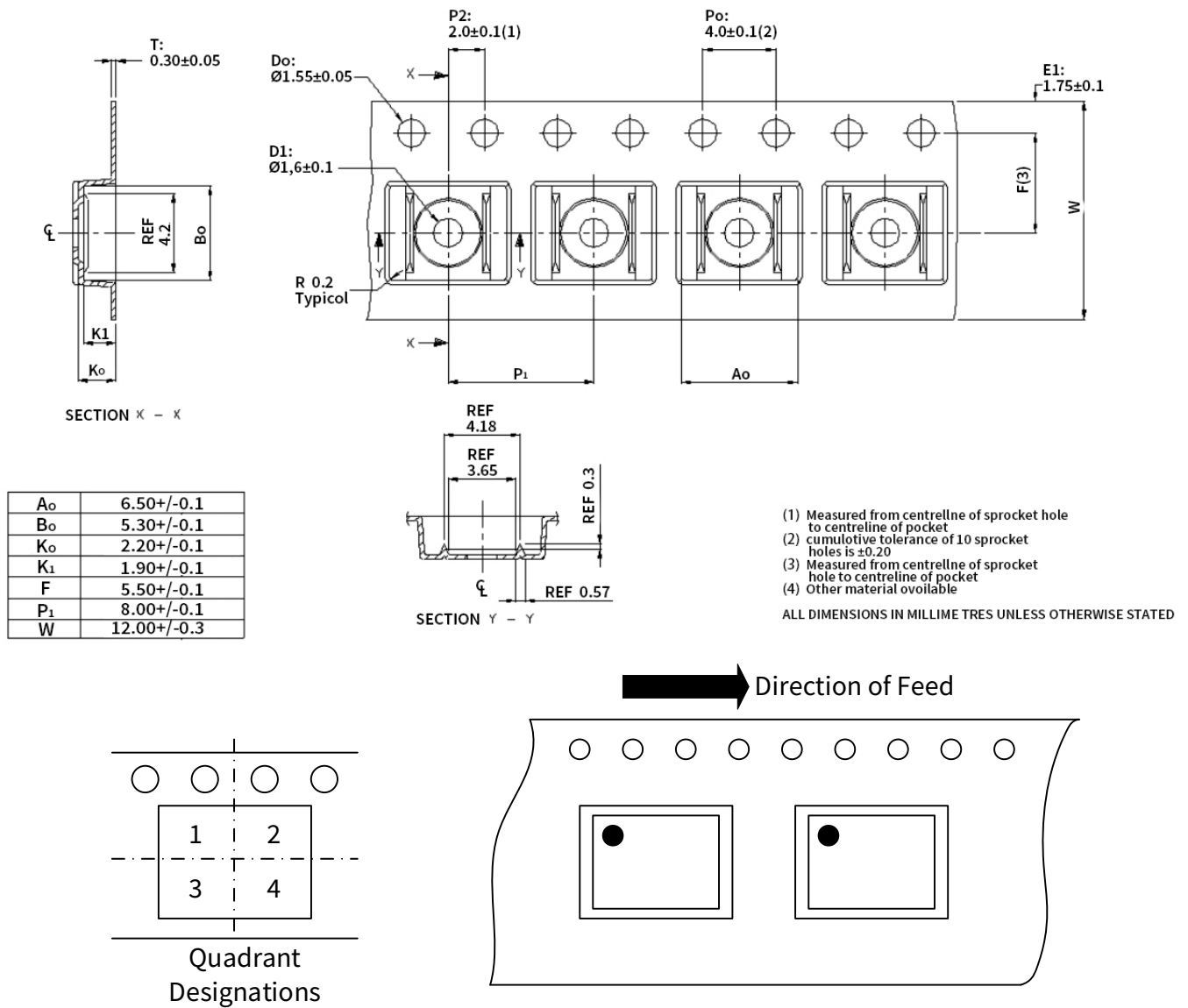
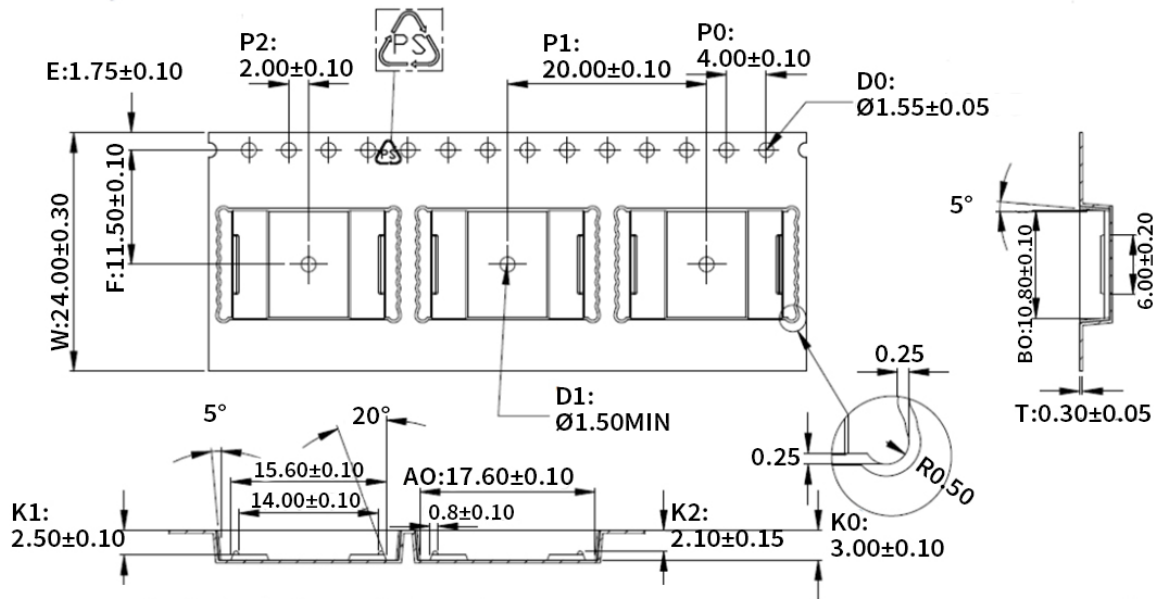

Figure 12.3 Tape Information of SSOP16



1. 10 sprocket hole pitch cumulative tolerance ± 0.20 .
2. Carrier camber is within 1 mm in 250 mm.
3. Material : Black Conductive Polystyrene Alloy.
4. All dimensions meet EIA-481 requirements.
5. Thickness: 0.30 ± 0.05 mm.
6. Packing length per 19" reel: 246.0 Meters.(Rewind 1:13)
7. Component load per 13" reel: 5000 pcs.
8. Surface resistivity: $10^5 \sim 10^{10} \Omega / \square$

W	24.00±0.30
A0	17.60±0.10
B0	10.80±0.10
K0	3.00±0.10
K1	2.50±0.10

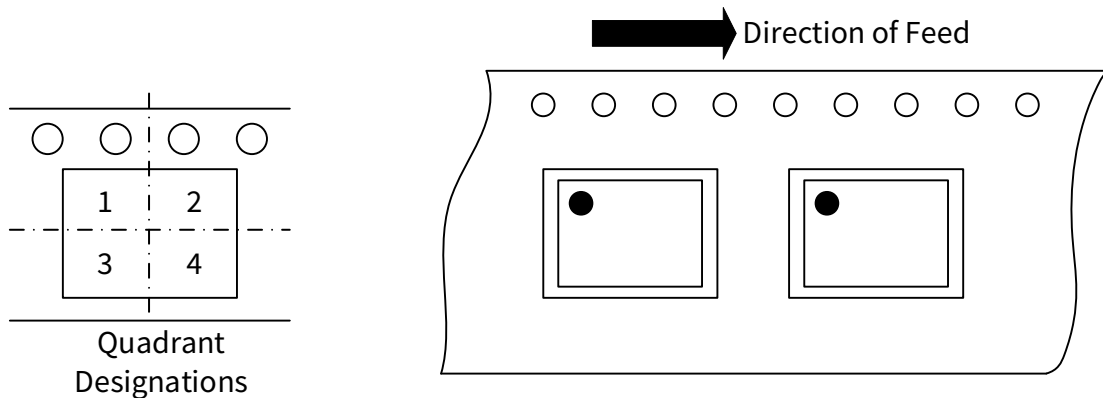

Figure 12.4 Tape Information of SOP16(600mil)

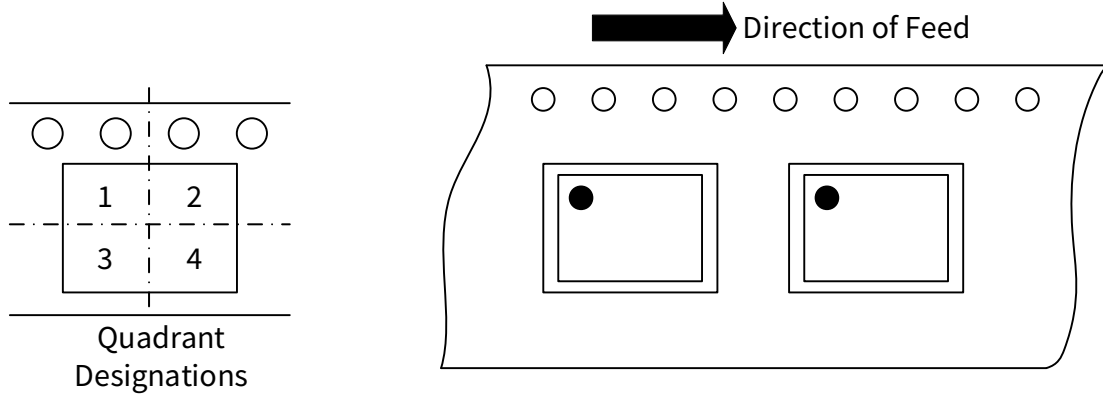
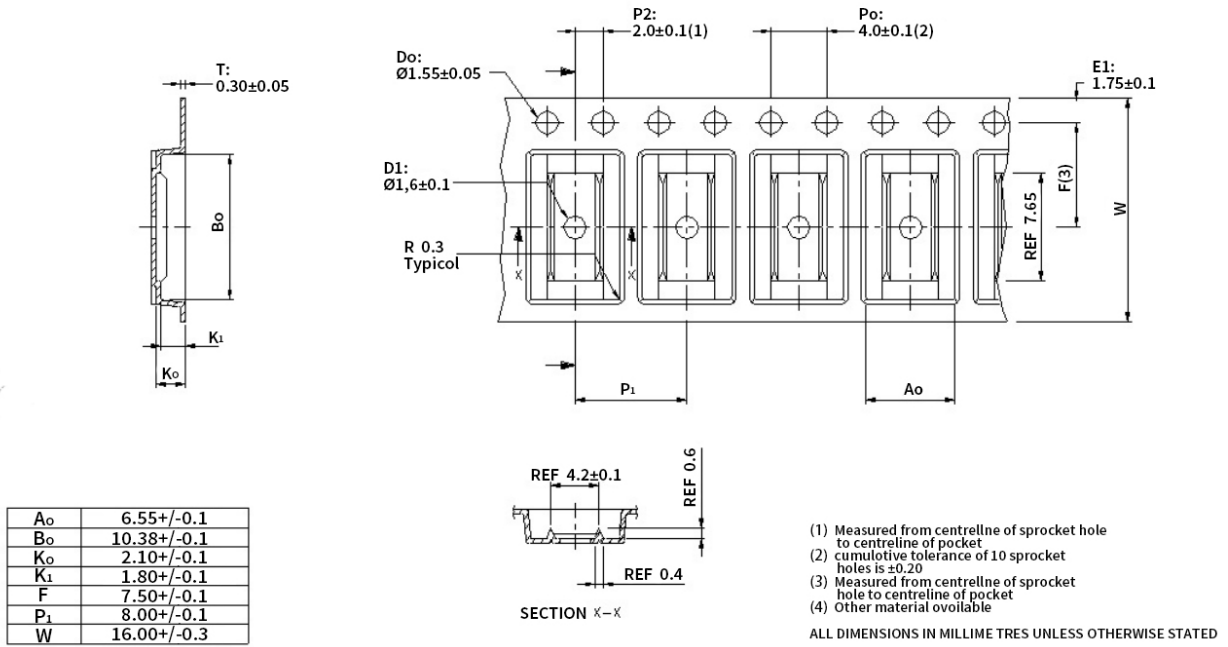

Figure 12.5 Tape Information of SOP16(150mil)

13. Revision history

Revision	Description	Date
1.0	Initial version	2020/11/20
1.1	Changed tape and reel information, changed format.	2021/2/4
1.2	Operating temperature support -55 to 125°C	2021/7/7
1.3	Add SSOP16 and SOP16 package. Update Part Number Rule, Package Board Layout Example. Update SOWW16 VISO.	2022/8/16
1.4	Update SOWW16 body size, CQC certification version	2023/2/14
1.5	Correct formatting and images. Delete NSI823xBWx. Update Input characteristics. Update Safety certification info throughout the document. Update eye diagram. Update Package Information. Update Function Description.	2025/1/21

IMPORTANT NOTICE

The information given in this document shall in no event be regarded as any warranty or authorization of, express or implied, including but not limited to accuracy, completeness, merchantability, fitness for a particular purpose or infringement of any third party's intellectual property rights.

You are solely responsible for your use of Novosense' products and applications, and for the safety thereof. You shall comply with all laws, regulations and requirements related to Novosense's products and applications, although information or support related to any application may still be provided by Novosense.

The resources are intended only for skilled developers designing with Novosense' products. Novosense reserves the rights to make corrections, modifications, enhancements, improvements or other changes to the products and services provided. Novosense authorizes you to use these resources exclusively for the development of relevant applications designed to integrate Novosense's products. Using these resources for any other purpose, or any unauthorized reproduction or display of these resources is strictly prohibited. Novosense shall not be liable for any claims, damages, costs, losses or liabilities arising out of the use of these resources.

For further information on applications, products and technologies, please contact Novosense (www.novosns.com).

Suzhou Novosense Microelectronics Co., Ltd