

USB PD and Other Fast Charging Protocol Sink Controller CH224

Datasheet
Version: 1F
<http://wch.cn>

1. Overview

CH224 integrates multiple fast charging protocols such as USB PD3.0/2.0, BC1.2, automatically detects VCONN and simulates E-Mark chips, and supports up to 100W power. CH224 has a built-in PD communication module, with features of high integration and streamlined peripherals. It integrates output voltage detection function, and provides over-temperature and over-voltage protection functions, etc. It can be widely used in various electronic equipment to expand high-power input, such as wireless charger, electric toothbrush, rechargeable shaver, lithium battery power tools and other application scenarios.

2. Features

- Supports 4V to 22V input voltage
- Supports fast charging protocols such as PD3.0/2.0 and BC1.2.
- Supports USB Type-C PD. Supports forward and reverse plug detection and automatic switching
- Supports E-Mark simulation and automatic detection of VCONN, and supports 100W power PD request
- The requested voltage can be dynamically adjusted by a variety of methods
- The single chip has features of high integration, simplified peripherals and low costs
- Built-in over-voltage protection module and over-temperature protection module

3. Applications

- Wireless charger
- Laptop charging cable
- Lithium battery minor electric appliances
- Lithium battery electric tool
- Power bank

4. Pinouts and pin description

4.1. CH224 pinouts

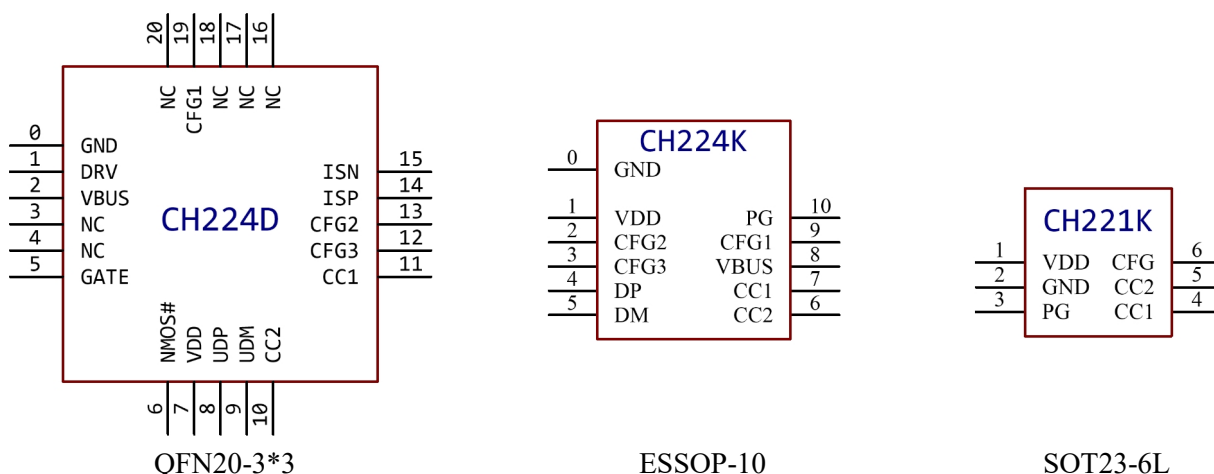

4.2. CH221K pin description

Pin No.	Pin name	Pin type	Pin description
1	VDD	Power	Operating power input. An external 1uF decoupling capacitor is required. Connected in series with a resistor to VBUS.
2	GND	Power	Ground
3	PG	Open-drain output	Indicate Power Good by default. Active low. Customized functions.
4, 5	CC1, CC2	Input/Output	Type-C CC data line
6	CFG	Analog input	Power configuration input

4.3. CH224K pin description

Pin No.	Pin name	Pin type	Pin description
0	GND	Power	Ground. Heat dissipation EPAD.
1	VDD	Power	Operating power input. An external 1uF decoupling capacitor is required. Connected in series with a resistor to VBUS.
4, 5	DP, DM	Input/Output	USB data line
6, 7	CC1, CC2	Input/Output	Type-C CC data line
2, 3, 9	CFG1, CFG2, CFG3	Analog input	Power configuration input
8	VBUS	Analog input	Voltage detection input. It is required to be connected in series with a resistor to external input VBUS.
10	PG	Open-drain output	Indicate Power Good by default. Active low. Customized functions.

4.4. CH224D pin description

Pin No.	Pin name	Pin type	Pin description
CH224D			
0	GND	Power	Ground. Heat dissipation EPAD
2	VBUS	Power	Operating power input
7	VDD	Power	Internal voltage regulator output. An external 1uF decoupling capacitor is required.
8, 9	DP, DM	Input/Output	USB data line
10, 11	CC1, CC2	Input/Output	Type-C CC data line
19, 13, 12	CFG1~3	Input	CFG1 is analog input. CFG2 and CFG3 are digital inputs, with built-in pull-down resistors.
1	DRV	Analog output	Weak driving output. Used to drive configuration resistor.
14, 15	ISP, ISN	Differential input	Used to detect operating current. Customized functions.
5	GATE	HV output	Used to drive high-side power channel NMOS. Customized functions.
6	NMOS#	Digital input	GATE pin drive NMOS enable. Active low.

5. Functional specification

5.1. Overview

CH224 is a USB PD sink controller, supports fast charge protocols such as PD3.0/2.0 and BC1.2, supports 4V to 22V, and can dynamically configure the request-voltage through multiple methods.

CH221K only supports PD3.0/2.0 protocols.

CH224K/CH224D supports resistance configuration mode and level configuration mode. CH221K only supports resistance configuration mode.

5.2. Request-voltage configuration (CH224K/CH224D)

5.2.1 Resistance configuration mode

It is suitable for applications to achieve different request-voltages by modifying the value of the resistor in a single PCB.

CFG1 is connected with a resistor to GND. Different request-voltages are available by configuring different resistance values. In resistor configuration mode, the CFG2 and CFG3 pins cannot be connected. The resistances and the corresponding request-voltages are shown in the table below.

Resistance on CFG1	Request-voltage
6.8K Ω	9V
24K Ω	12V
56K Ω	15V
NC	20V

5.2.2 Level configuration mode

It is suited when an MCU is used to dynamically adjust the request-voltage, or when the PCB circuit is not changed.

CFG1, CFG2 and CFG3 can be directly connected to the external MCU IO ports, or directly connected to the VDD/GND pin on CH224K/CH224D. Different request-voltages are available by configuring the level on the 3 pins, as shown in the table below.

CFG1	CFG2	CFG3	Request-voltage
1	-	-	5V
0	0	0	9V
0	0	1	12V
0	1	1	15V
0	1	0	20V

In level configuration mode, the voltage on IO ports and default states should be noted.

For CH224K, the input voltage on CFG2/CFG3 cannot be higher than 3.7V. For CH224D, the input voltage on CFG2/CFG3 cannot be higher than 5V.

If the back-end circuits such as MCU start slowly, or if the MCU pins have a specific default state, CFG1 may be in floating state or in IO configuration mode before MCU starts working. In this case, 20V may be requested. If the system cannot withstand 20V input, a configuration resistor should be added to the CFG1 pin to ensure that CH224K/CH224D can request a suitable voltage by configuring the resistor before MCU starts working.

5.3. CH221K voltage configuration

CFG is connected with a resistor to VDD. Different request voltages are available by configuring different resistances, as shown in the table below.

Resistance on CFG to VDD	Request-voltage
10KΩ	5V
20KΩ	9V
47KΩ	12V
100KΩ	15V
200KΩ	20V

5.4. E-Mark simulation function

If you need to simulate E-Mark function to request voltage higher than 20V or power higher than 60W, you must use a Type-C male plug, and connect the CC2 pin with a 1 KΩ resistor to GND. (Please contact us for technical support)

5.5. Only PD protocol used

If there is no need to use A-port protocols (varies protocols realized by DP.DM communication), CH221K can be selected.

If you want to block these protocols on CH224K/CH224D, the DP/DM pin on CH224K/CH224D is required to be disconnected from the DP/DM on the Type-C connector, and the DP pin on CH224 is required to be shorted to the DM on CH224. For CH224K, the VBUS pin can be NC.

6. Reference schematic diagram

6.1. Connect CH224K/CH224D with a Type-C female port

9/12/15/20V request-voltage configuration by resistance (In the figures below, a 6.8 KΩ resistor is used to configure 9V request voltage)

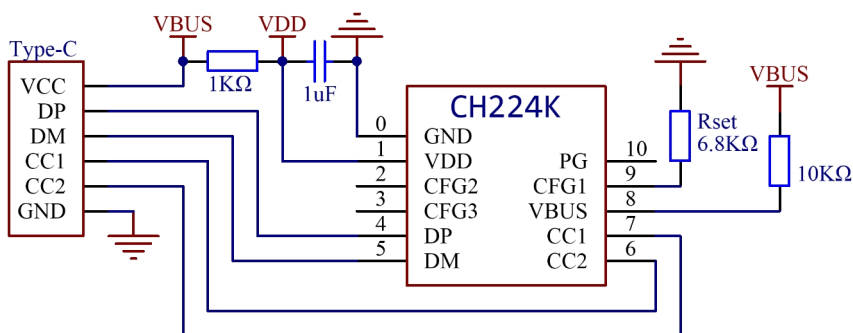

Rset	Request-voltage
6.8 KΩ	9V
24 KΩ	12V
56 KΩ	15V
NC	20V

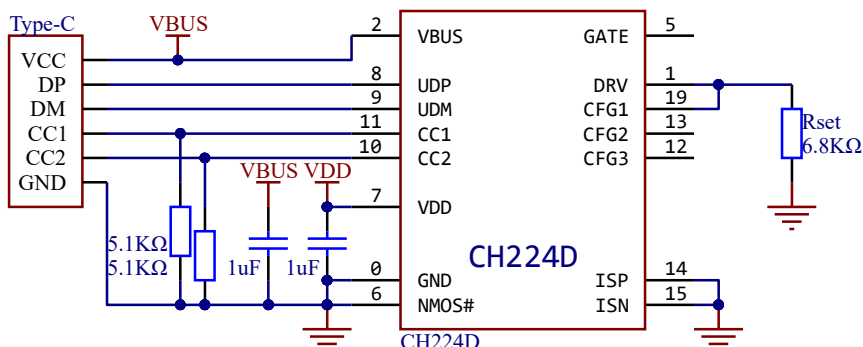

6.2. Connect CH224K with a Type-C female port

5/9/12/15/20V request-voltage configuration by level (In the figure below, the request voltage is configured to 12V by level)

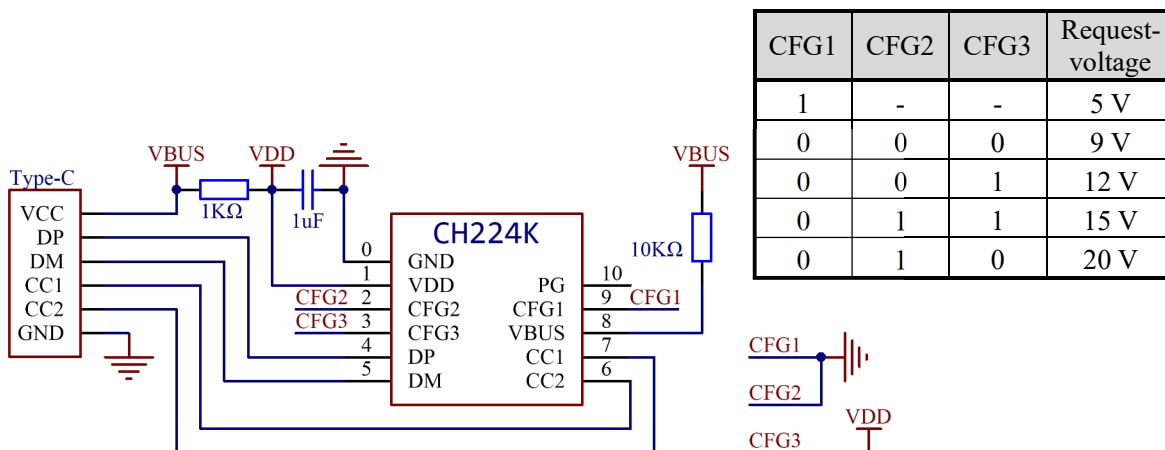

6.3. Connect CH224K with a Type-C male port

Only PD protocol is used, with E-Mark simulation function (In the figure below, the request voltage is configured to 20V with the resistor NC)

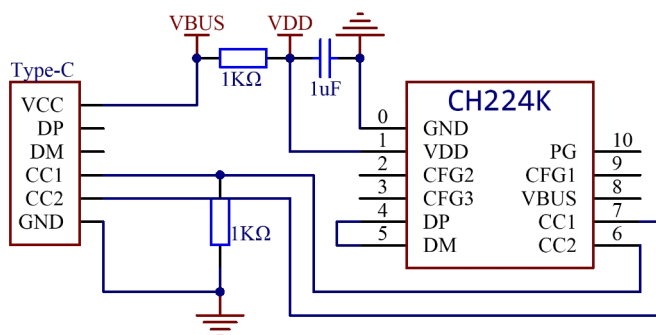

6.4. Connect CH221K with a Type-C male port

20V request-voltage configuration by level

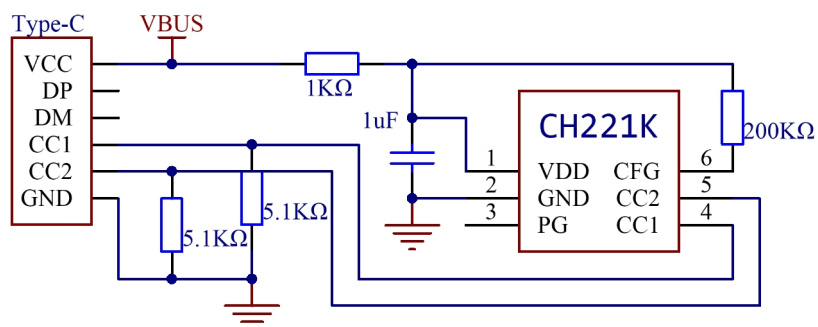

7. Parameters

7.1. Absolute maximum ratings of CH221K

Operating in critical ratings or exceeding the absolute maximum ratings may cause the chip to work abnormally or even be damaged.

Symbol	Parameter description	Min.	Max.	Unit
TA	Operating ambient temperature	-40	105	°C
TS	Storage ambient temperature	-55	150	°C
VDD	Operating supply voltage (VDD is connected to power, GND to ground)	-0.5	5.8	V
VODHV	Voltage on high-voltage open-drain output pin PG	-0.5	13.5	V
VIOCC	Voltage on CC1 and CC2	-0.5	8	V
VIOUX	Voltage on CFG	-0.5	VDD+0.5	V
PD	Maximum power consumption of the entire chip (VDD voltage * current)		250	mW

7.2. Absolute maximum ratings of CH224K

Operating in critical ratings or exceeding the absolute maximum ratings may cause the chip to work abnormally or even be damaged.

Symbol	Parameter description	Min.	Max.	Unit
TA	Operating ambient temperature	-40	90	°C
TS	Storage ambient temperature	-55	105	°C
VDD	Operating supply voltage (VDD is connected to power, GND to ground)	3.0	3.6	V
VIOHV	Voltage on CFG and VBUS which support high voltage	-0.5	13.5	V
VIOCC	Voltage on CC1, CC2 and CFG1	-0.5	8	V
VIOUX	Voltage on DP, DM, CFG, CFG2 and CFG3	-0.5	VDD+0.5	V
VIOLV	Voltage on CFGHV		0.8	V
PD	Maximum power consumption of the entire chip (VDD voltage * current)		400	mW

7.3. Absolute maximum ratings of CH224D

Operating in critical ratings or exceeding the absolute maximum ratings may cause the chip to work abnormally or even be damaged.

Symbol	Parameter description	Min.	Max.	Unit
TA	Operating ambient temperature	-40	100	°C
TS	Storage ambient temperature	-55	125	°C
VDD	Operating supply voltage (VDD is connected to power, GND to ground)	-0.5	6	V
VIOHV	Voltage on VBUS	-0.5	24	V
VIOCC	Voltage on CC1 and CC2	-0.5	20	V
VIOUX	Voltage on DP, DM, CFG1, CFG2, CFG3, DRV, NMOS#, ISP and ISN	-0.5	VDD+0.5	V
VIOHX	Voltage on GATE	-0.5	VIOHV+6.5	V
PD	Maximum power consumption of the entire chip (VDD voltage * current)		300	mW

7.4. Electrical characteristics of CH221K

Test condition: TA=25°C

Symbol	Parameter description	Min.	Typ.	Max.	Unit
VLDOK	CH221K internal power regulator VDD parallel voltage	3.0	3.3	3.6	V
ILDO	Draw current on VDD pin	0		30	mA
VR	Voltage threshold of power-on reset	2.2	2.4	2.6	V

7.5. Electrical characteristics of CH224K

Test condition: TA=25°C

Symbol	Parameter description	Min.	Typ.	Max.	Unit
VLDOK	CH224K internal power regulator VDD parallel voltage	3.24	3.3	3.36	V
ILDO	Draw current on VDD pin	0		30	mA
TOTA	Reference threshold of the over-temperature module (OTA)	90	105	120	°C
VR	Power-on reset threshold	2.2	2.4	2.6	V

7.6. Electrical characteristics of CH224D

Test condition: TA=25°C

Symbol	Parameter description	Min.	Typ.	Max.	Unit
VLDO	Internal power regulator VDD output voltage	4.65	4.7	4.75	V
ILDO	Internal power regulator VDD out-load capability			10	mA
VR	Power-on reset threshold	2.2	2.4	2.6	V

8. Package

Package	Body size		Lead pitch		Description	Part No.
QFN20	3*3mm	118mil	0.40mm	15.7mil	Quad flat no-lead package	CH224D
ESSOP10	3.9mm	150mil	1.00mm	39mil	Shrink small outline package with EPAD 10-pin patch	CH224K
SOT23-6L	1.6mm	63mil	0.95mm	37mil	Small outline 6-pin patch	CH221K

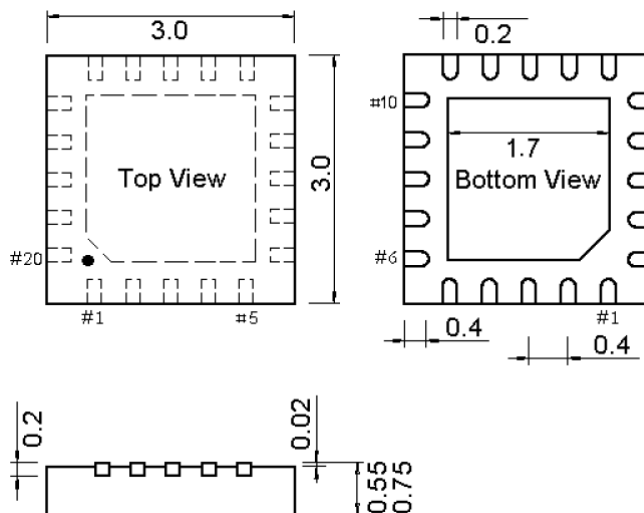

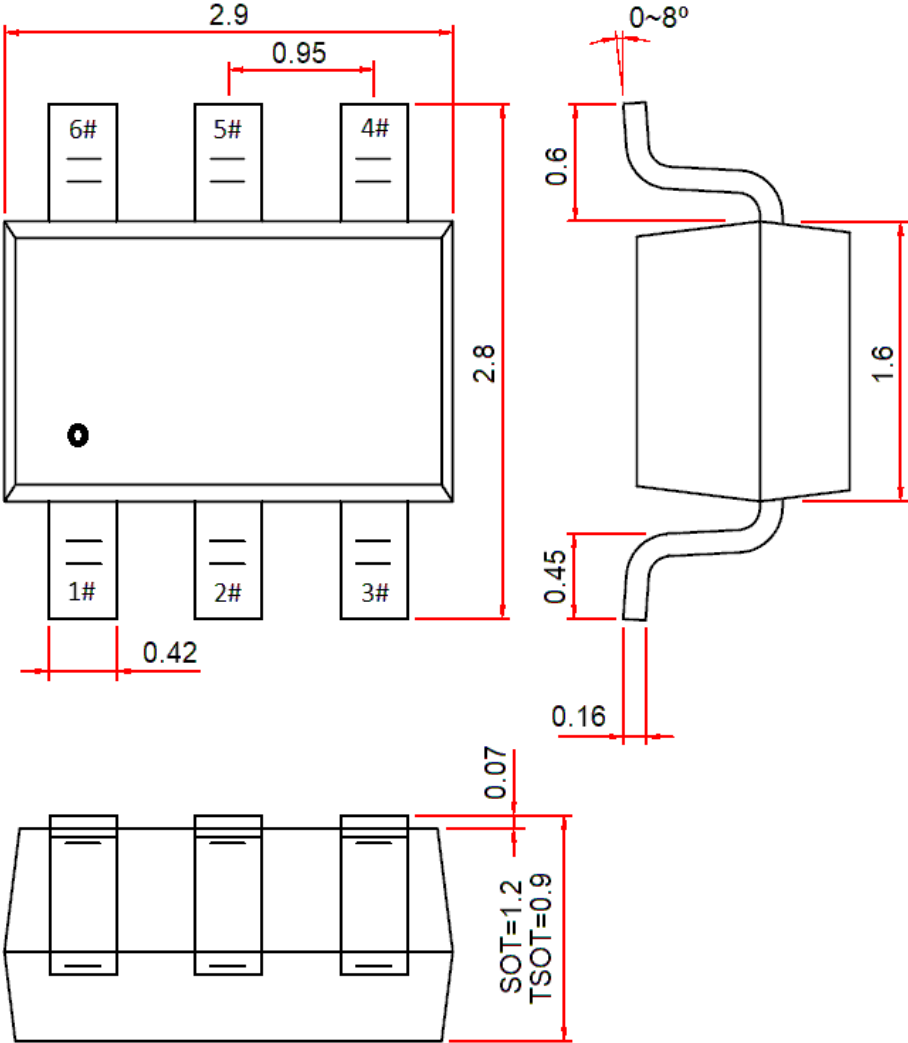
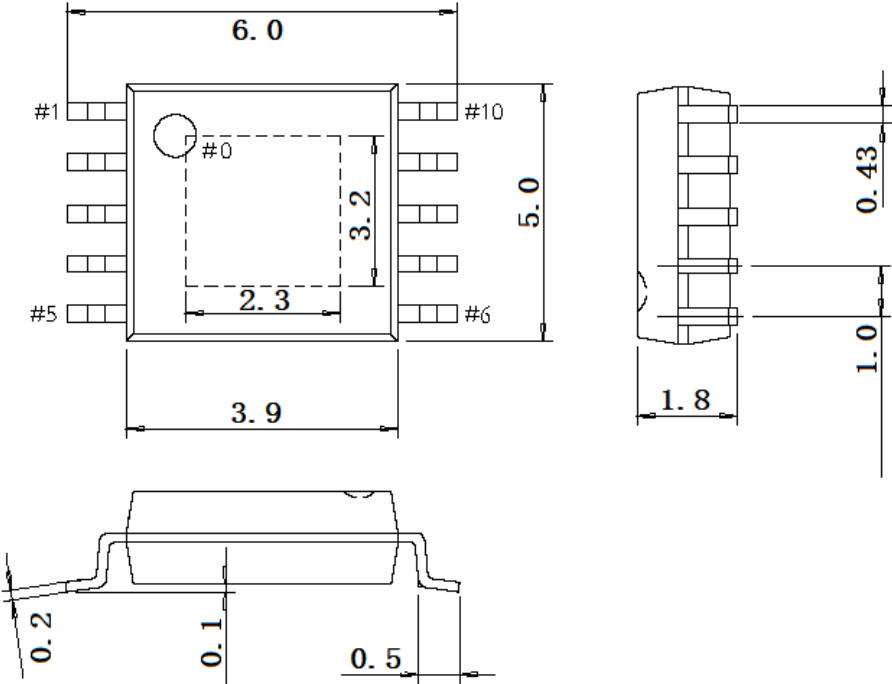

Note: All dimensions are in millimeters.