

1/4-inch 2 MP CMOS Digital Image Sensor

AR0246

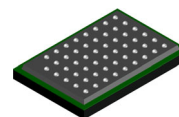

ODCSP53
CASE 570AA

General Description

The **onsemi** AR0246 is a stacked 1/4-inch back side illuminated (BSI) CMOS active-pixel digital image sensor with a pixel array of 1920 (H) x 1080 (V). The sensor has enhanced NIR response. It captures images in either linear or high dynamic range modes with a rolling shutter readout, and includes sophisticated camera functions such as binning, windowing and both video and single frame modes. It is designed for both low light and high dynamic range performance. AR0246 can combine on chip up to three exposures and compand to 12-bit HDR output (eHDR) or it could provide line interleaved output of two exposures to support off chip HDR (LI-HDR) in an ISP chip. It could also provide enhanced Dynamic Range (eDR) from single exposure. The AR0246 produces extraordinarily clear, sharp digital pictures, and its ability to capture both continuous video and single frame enhanced NIR response makes it the perfect choice for security applications.

Table 1. KEY PERFORMANCE PARAMETERS

Parameter	Typical Value
Optical Format	1/4-inch (4.41 mm Diagonal, 16:9)
Active Pixels	1920 (H) x 1080 (V)
Pixel Size	2.0 μm x 2.0 μm , BSI
Color Filter Array	RGB
Chief Ray Angle	10°, 32°
Shutter Type	ERS and GRR
One-Time Programmable Memory (OTPM)	160 Bytes
Input Clock Range	6 ~ 48 MHz
Output Interface	2-lane MIPI (2 lanes, 1 Gbps/lane)
ADC Resolution	12-bit on die
Global Gain Range Analog Gain: Digital Gain:	0 dB to 42 dB (in steps of 0.375 dB) 0-18 dB 18-42 dB
Frame Rate	Linear: 1080p @ 60 fps LI-HDR (2exp): 1080p @ 30 fps eHDR (3 exp): 1080p @ 30 fps eDR (1 exp): 1080p @ 30 fps
Subsampling	Bin2, skip2
Multi-camera Support	Frame Rate and Exposure Synchronization
Responsivity	18 ke-/lux*s
SNR _{MAX}	39 dB
Dynamic Range	80 dB – eDR Mode Dynamic Range 120 dB – eHDR Mode Dynamic Range 96 dB – LI-HDR Mode Dynamic Range

Non-NDA Data Sheet

Interested in what you see? If you would like more detailed information, please request the full version of our data sheet.

[Request Full Data Sheet](#)

Features

- 1080p (1920 x 1080, Full Resolution of 2 MP) at 60 fps Linear Mode Video Capture
- Full Resolution at 30 fps, 3-exposure embedded High Dynamic Range (eHDR) Video Capture with Exposure Ratio Control
- Full Resolution at 45 fps, enhanced Dynamic Range (eDR) Video Capture for enhanced Dynamic Range from Single Exposure with No Motion Artifacts from Multiple Exposures
 - ◆ Full Resolution at 30 fps, 2-exposure Line Interleaved enhanced Dynamic Range (LI-eDR) Video Capture
- Full Resolution at 30 fps, 2-exposure Line Interleave HDR (LI-HDR) Video Capture. T1/T2 Readout to Enable HDR Processing in ISP Chip
- Adaptive Local Tone Mapping (ALTM) Supported to Compress High Dynamic Range Image to Available Display Device Range
- Super Low Power Mode (SLP)
- Wake on Motion (WOM)/Motion Detection
 - ◆ Motion Detection, Auto Wake Up from Standby Mode (240 x 135 full Resolution)
- Context Switching
- Electronic Rolling Shutter (ERS) and Global Reset Release (GRR) Modes Supported
- Triggered Integration and Readout Control

Table 1. KEY PERFORMANCE PARAMETERS (continued)

Parameter	Typical Value
Supply Voltage I/O	1.8 V (1.7 V < V _{supply} < 1.9 V) or 2.8 V (2.7 V < V _{supply} < 2.9 V)
Digital	1.05 V (1 V < V _{supply} < 1.1 V)
Analog	2.8 V (2.7 V < V _{supply} < 2.9 V)
Power Consumption (Typical)	Linear 60 fps: 180 mW (Note 1) eHDR 30 fps: 281 mW (Note 1)
Operating Temperature	(-30 °C < T _J < +85 °C)
Optimal Performance Temperature	(0 °C < T _J < +60 °C)
Package Options	5.31 mm x 3.61 mm 53-pin CSP package Bare Die
θ _{JA} (Note 2)	41.65 °C/W (Note 2)
θ _{JB}	13.45 °C/W

1. Power consumption numbers are estimated values.
2. θ_{JA} is dependent on the customer module design and should not be used for calculating junction temperature.

Applications

- Security
- IoT
- Car DVR

Table 2. 12-bit MODE OF OPERATION AND POWER

Mode Name	Mode Description	Resolution	Frame Rate
Native	1080p Linear	1920 x 1080	60
Native	1080p Linear, Lower Frame Rate	1920 x 1080	30
eHDR Native	1080p eHDR 2exp	1920 x 1080	45
eHDR 3exp Native	1080p eHDR 3exp	1920 x 1080	30
eHDR 3exp ALTM Native	1080p eHDR 3exp ALTM	1920 x 1080	30
LI Native	1080p LI-HDR 2exp	1920 x 1080	30
WoM bin4skip2 (Note 3)	Wake on Motion w/ Streaming	240 x 135	1
Bin2	0.5 MP Linear	960 x 540	180
eDR Native	1080p eDR	1920 x 1080	45
eDR ALTM Native	1080p eDR ALTM	1920 x 1080	45
LI-eDR Native	1080p LI-eDR	1920 x 1080	30
SLP Native	1080p SLP	1920 x 1080	1

3. Actual resolution of sensor is 480 x 135 with every alternate col being dummy pixel output, active resolution is 240 x 135.

AR0246

Table 3. ORDERING INFORMATION

Part Number	Product Description				Orderable Product Attribute Description
AR0246NPSC10SMKA1-CP	2 MP	RGB	10° CRA	Production Part	Chip Tray with Protective Film
AR0246NPSC10SMKA1-CP2	2 MP	RGB	10° CRA	Production Part	Chip Tray with Protective Film Low MOQ
AR0246NPSC10SMKA1-CR	2 MP	RGB	10° CRA	Production Part	Chip Tray without Protective Film

AR0246NPSC32SMKA1-CP	2 MP	RGB	32° CRA	Production Part	Chip Tray with Protective Film
AR0246NPSC32SMKA1-CP2	2 MP	RGB	32° CRA	Production Part	Chip Tray with Protective Film Low MOQ
AR0246NPSC32SMKA1-CR	2 MP	RGB	32° CRA	Production Part	Chip Tray without Protective Film

AR0246NPSC10SMKAH3-GEVB	2 MP	RGB	10° CRA		Demo Headboard
AR0246NPSC32SMKAH3-GEVB	2 MP	RGB	32° CRA		Demo Headboard

NOTE: Refer to AR0246 Die Data Sheet for Die Part Numbers & Ordering Information.

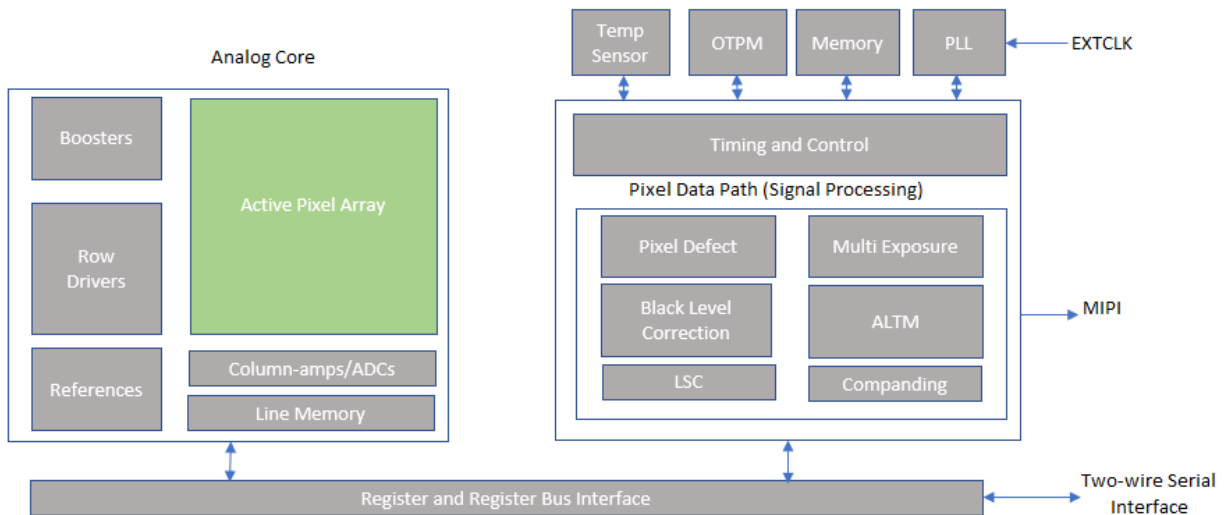
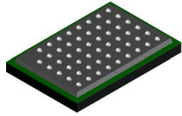

Figure 1. Block Diagram

AR0246

REVISION HISTORY

Revision	Description of Changes	Date
5	Updated maximum number of contexts in context switching section.	05/20/2025



**ODCSP53 5.31x3.61x0.63, 0.5P
CASE 570AA
ISSUE C**

DATE 03 APR 2024

NOTES:

1. DIMENSIONING AND TOLERANCING PER ASME Y14.5M, 2018.
2. CONTROLLING DIMENSION: MILLIMETERS [mm].
3. SOLDER BALL DIAMETER IS MEASURED AT THE MAXIMUM SOLDER BALL DIAMETER PARALLEL TO DATUM C.
4. COPLANARITY APPLIES TO THE SPHERICAL CROWNS OF THE SOLDER BALLS.
5. DATUM C, THE SEATING PLANE IS DEFINED BY THE SPHERICAL CROWNS OF THE SOLDER BALLS.
6. GLASS: 0.400 THICKNESS; REFRACTIVE INDEX = 1.52.
7. AIR GAP BETWEEN GLASS AND PIXEL ARRAY: 0.040 THICKNESS.
8. PARALLELISM APPLIES ONLY TO THE ACTIVE ARRAY.
9. MAXIMUM ROTATION OF ACTIVE ARRAY RELATIVE TO DATUMS A AND B IS ±0.1°.
10. REFER TO THE DEVICE DATA SHEET FOR TOTAL PIXEL ARRAY DEFINITIONS.
11. PACKAGE CENTER (X, Y) = (0.000, 0.000).
12. OPTICAL CENTER RELATIVE TO PACKAGE CENTER (X, Y) = (0.000, 0.000).

MILLIMETERS			
DIM	MIN	NOM	MAX
A	---	---	0.762
A1	0.081	0.101	0.121
A2	0.631 REF		
A3	0.426	0.440	0.454
A4	0.180	0.191	0.202
b	0.184	0.204	0.224
D	5.290	5.315	5.340
D1	3.840 REF		
D2	2.633	2.658	2.683
E	3.590	3.615	3.640
E1	2.160 REF		
E2	1.783	1.808	1.833
e	0.500 BSC		
e/2	0.250 BSC		

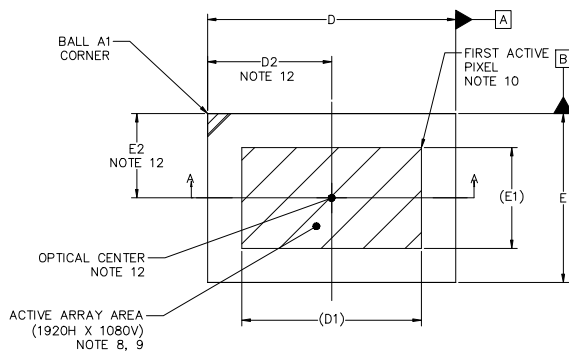

TOP VIEW

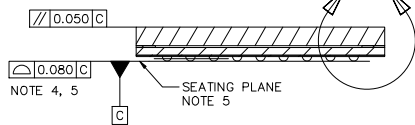

SECTION A-A

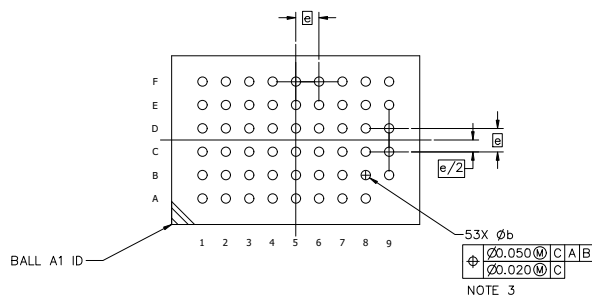

BOTTOM VIEW

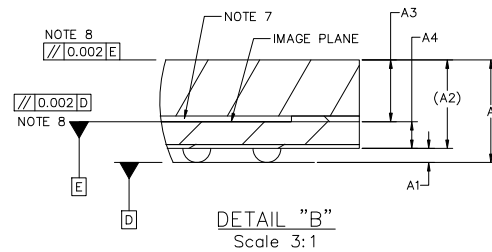

DETAIL "B"
Scale 3:1

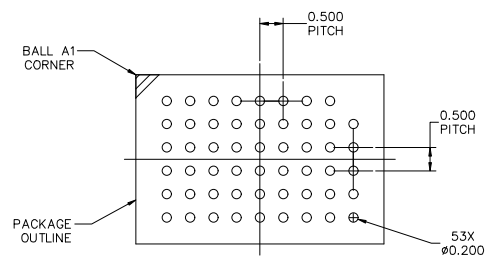

RECOMMENDED MOUNTING FOOTPRINT*

*FOR ADDITIONAL INFORMATION ON OUR Pb-FREE STRATEGY AND SOLDERING DETAILS, PLEASE DOWNLOAD THE ON SEMICONDUCTOR SOLDERING AND MOUNTING TECHNIQUES REFERENCE MANUAL, SOLDERRM/D.

DOCUMENT NUMBER:	98AON83888G	Electronic versions are uncontrolled except when accessed directly from the Document Repository. Printed versions are uncontrolled except when stamped "CONTROLLED COPY" in red.
DESCRIPTION:	ODCSP53 5.31x3.61x0.63, 0.5P	PAGE 1 OF 1

onsemi and ONSEMI are trademarks of Semiconductor Components Industries, LLC dba onsemi or its subsidiaries in the United States and/or other countries. onsemi reserves the right to make changes without further notice to any products herein. onsemi makes no warranty, representation or guarantee regarding the suitability of its products for any particular purpose, nor does onsemi assume any liability arising out of the application or use of any product or circuit, and specifically disclaims any and all liability, including without limitation special, consequential or incidental damages. onsemi does not convey any license under its patent rights nor the rights of others.

onsemi, **Onsemi**, and other names, marks, and brands are registered and/or common law trademarks of Semiconductor Components Industries, LLC dba "**onsemi**" or its affiliates and/or subsidiaries in the United States and/or other countries. **onsemi** owns the rights to a number of patents, trademarks, copyrights, trade secrets, and other intellectual property. A listing of **onsemi**'s product/patent coverage may be accessed at www.onsemi.com/site/pdf/Patent-Marking.pdf. **onsemi** reserves the right to make changes at any time to any products or information herein, without notice. The information herein is provided "as-is" and **onsemi** makes no warranty, representation or guarantee regarding the accuracy of the information, product features, availability, functionality, or suitability of its products for any particular purpose, nor does **onsemi** assume any liability arising out of the application or use of any product or circuit, and specifically disclaims any and all liability, including without limitation special, consequential or incidental damages. Buyer is responsible for its products and applications using **onsemi** products, including compliance with all laws, regulations and safety requirements or standards, regardless of any support or applications information provided by **onsemi**. "Typical" parameters which may be provided in **onsemi** data sheets and/or specifications can and do vary in different applications and actual performance may vary over time. All operating parameters, including "Typicals" must be validated for each customer application by customer's technical experts. **onsemi** does not convey any license under any of its intellectual property rights nor the rights of others. **onsemi** products are not designed, intended, or authorized for use as a critical component in life support systems or any FDA Class 3 medical devices or medical devices with a same or similar classification in a foreign jurisdiction or any devices intended for implantation in the human body. Should Buyer purchase or use **onsemi** products for any such unintended or unauthorized application, Buyer shall indemnify and hold **onsemi** and its officers, employees, subsidiaries, affiliates, and distributors harmless against all claims, costs, damages, and expenses, and reasonable attorney fees arising out of, directly or indirectly, any claim of personal injury or death associated with such unintended or unauthorized use, even if such claim alleges that **onsemi** was negligent regarding the design or manufacture of the part. **onsemi** is an Equal Opportunity/Affirmative Action Employer. This literature is subject to all applicable copyright laws and is not for resale in any manner.

ADDITIONAL INFORMATION

TECHNICAL PUBLICATIONS:

Technical Library: www.onsemi.com/design/resources/technical-documentation
onsemi Website: www.onsemi.com

ONLINE SUPPORT: www.onsemi.com/support

For additional information, please contact your local Sales Representative at www.onsemi.com/support/sales