



**Battery Charger Flash MCU**

**HT45F5Q-3**

Revision: V1.30 Date: September 05, 2025

[www.holtek.com](http://www.holtek.com)

## Features

### CPU Features

- Operating voltage
  - ♦  $f_{SYS}=8\text{MHz}$ : 2.2V~5.5V
- Up to 0.5 $\mu\text{s}$  instruction cycle with 8MHz system clock at  $V_{DD}=5\text{V}$
- Power down and wake-up functions to reduce power consumption
- Oscillator types
  - ♦ Internal High Speed 8MHz RC – HIRC
  - ♦ Internal Low Speed 32kHz RC – LIRC
- Multi-mode operation: FAST, SLOW, IDLE and SLEEP
- Fully integrated internal high speed and low speed RC oscillators require no external components
- All instructions executed in one or two instruction cycles
- Table read instructions
- 61 powerful instructions
- 6-level subroutine nesting
- Bit manipulation instruction

### Peripheral Features

- Flash Program Memory: 4K $\times$ 15
- RAM Data Memory: 256 $\times$ 8
- Emulated EEPROM Memory: 32 $\times$ 15
- Watchdog Timer function
- 23 bidirectional I/O lines
- Two pin-shared external interrupts
- Multiple Timer Modules for time measurement, input capture, compare match output or PWM output or single pulse output function
- Universal Serial Interface Module – USIM for SPI, I<sup>2</sup>C or UART communication
- Dual Time-Base functions for generation of fixed time interrupt signals
- 10 external channel 12-bit resolution A/D converter
- Battery charger circuit
  - ♦ 14-bit D/A Converter and OPA0 are used for constant current control
  - ♦ 12-bit D/A Converter and OPA1 are used for constant voltage control
  - ♦ OPA2 is 20 times amplifier for current sense
- Software controlled 4-SCOM lines LCD driver with 1/2 bias
- 16-bit Cyclic Redundancy Check Unit
- Low voltage reset function
- Package types: 24/28-pin SSOP

## Development Tools

For rapid product development and to simplify device parameter setting, Holtek has provided relevant development tools which users can download from the following link:

[https://www.holtek.com/page/tool-detail/dev\\_plat/power/Charger\\_Development\\_Workshop](https://www.holtek.com/page/tool-detail/dev_plat/power/Charger_Development_Workshop)

[https://www.holtek.com/page/tool-detail/dev\\_plat/power/Charger\\_Volume\\_Production\\_Fixture](https://www.holtek.com/page/tool-detail/dev_plat/power/Charger_Volume_Production_Fixture)

## General Description

The HT45F5Q-3 is a Flash Memory A/D type 8-bit high performance RISC architecture microcontroller especially designed for battery charger applications.

For memory features, the Flash Memory offers users the convenience of multi-programming features. Other memory includes an area of RAM Data Memory as well as an area of Emulated EEPROM memory for storage of non-volatile data such as serial numbers, calibration data etc.

Analog feature includes a multi-channel 12-bit A/D converter function. An extremely flexible Timer Module provides timing, pulse generation and PWM generation functions. Communication with the outside world is catered for by including fully integrated SPI, I<sup>2</sup>C and UART interface functions, three popular interfaces which provide designers with a means of easy communication with external peripheral hardware. Protective features such as an internal Watchdog Timer and Low Voltage Reset coupled with excellent noise immunity and ESD protection ensure that reliable operation is maintained in hostile electrical environments.

A full choice of internal low and high speed oscillator functions is provided including a fully integrated system oscillator which requires no external components for its implementation. The ability to operate and switch dynamically between a range of operating modes using different clock sources gives users the ability to optimise microcontroller operation and minimise power consumption.

For AC/DC charger applications, the device includes a battery charger management module, which can be used for the constant voltage and constant current closed loop charging control. The device therefore reduces the need for the usually required external TL431 component, operational amplifier and resistance analogic D/A Converter in traditional battery charging circuits. Therefore the peripheral circuit is more reduced, resulting in a smaller PCB area.

The charger management module is composed of two parts. The first part contains two groups of OPAs and D/A Converters, which are used to control the charging voltage and current. The upper limit value of the charger constant current and constant voltage can be obtained by configuring the D/A Converters in the software. The 14-bit D/A Converter is used for constant current control while the 12-bit D/A Converter is used for constant voltage control. The second part of the charger management contains a fixed gain operational amplifier which is used for current amplification. This improves the current resolution and allows the use of smaller current detection resistors thus reducing the resistor power consumption.

The D/A Converter in the charger management module is not only used for setting charging voltage and current, but also can be used together with the specific charger production fixtures for improving the traditional manual calibration techniques. By using the external production fixtures, the charger current voltage/current conditions can be confirmed. If the margin of errors is exceeded, the MCU will correct the error by fine tuning the D/A Converter, and store the corrected parameters to Emulated EEPROM. When the charger is recharged, the D/A Converter will be given a new correction value to implement correction purpose. Refer to the Holtek application notes for more details.

The inclusion of flexible I/O programming features, Time-Base functions along with many other features, further enhance device functionality and flexibility for wide range of application possibilities.



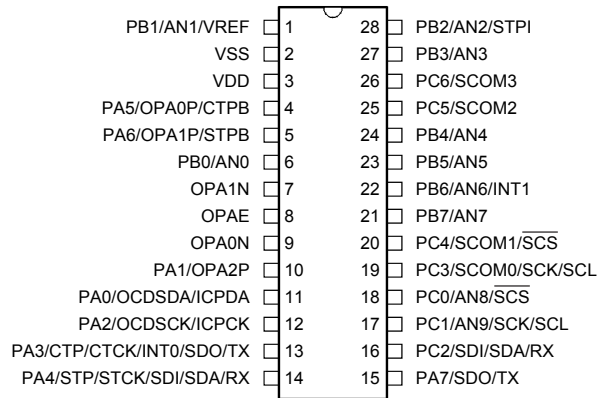

**HT45F5Q-3/HT45V5Q-3**  
**28 SSOP-A**

- Note: 1. If the pin-shared pin functions have multiple outputs simultaneously, the desired pin-shared function is determined by the corresponding software control bits.
2. The OCSDSA and OCDSCK pins are supplied for the OCDS dedicated pins and as such only available for the HT45V5Q-3 device which is the OCDS EV chip for the HT45F5Q-3 device.
3. For the less pin count package type there will be unbounded pins which should be properly configured to avoid unwanted power consumption resulting from floating input conditions. Refer to the “Standby Current Considerations” and “Input/Output Ports” sections.

## Pin Description

The function of each pin is listed in the following table, however the details behind how each pin is configured is contained in other sections of the datasheet. As the Pin Description table shows the situation for the package with the most pins, not all pins in the table will be available on smaller package sizes.

Pin Name	Function	OPT	I/T	O/T	Description
PA0/OCSDSA/ICPDA	PA0	PAPU PAWU	ST	CMOS	General purpose I/O. Register enabled pull-up and wake-up
	OCSDSA	—	ST	CMOS	OCDS address/data, for EV chip only
	ICPDA	—	ST	CMOS	ICP address/data
PA1/OPA2P	PA1	PAPU PAWU PAS0	ST	CMOS	General purpose I/O. Register enabled pull-up and wake-up
	OPA2P	PAS0	AN	—	Operational amplifier 2 positive input
PA2/OCDSCK/ICPCK	PA2	PAPU PAWU	ST	CMOS	General purpose I/O. Register enabled pull-up and wake-up
	OCDSCK	—	ST	—	OCDS clock, for EV chip only
	ICPCK	—	ST	—	ICP clock
PA3/CTP/CTCK/INT0/SDO/TX	PA3	PAPU PAWU PAS0	ST	CMOS	General purpose I/O. Register enabled pull-up and wake-up
	CTP	PAS0	—	CMOS	CTM output
	CTCK	PAS0	ST	—	CTM clock input
	INT0	PAS0 INTEG INTC0	ST	—	External interrupt 0 input
	SDO	PAS0	—	CMOS	SPI serial data output
TX	PAS0	—	CMOS	UART TX serial data output	

Pin Name	Function	OPT	I/T	O/T	Description
PA4/STP/STCK/SDI/SDA/RX	PA4	PAPU PAWU PAS1	ST	CMOS	General purpose I/O. Register enabled pull-up and wake-up
	STP	PAS1	—	CMOS	STM output
	STCK	PAS1	ST	—	STM clock input
	SDI	PAS1 IFS	ST	—	SPI serial data input
	SDA	PAS1 IFS	ST	NMOS	I <sup>2</sup> C data line
	RX	PAS1 IFS	ST	—	UART RX serial data input
PA5/OPA0P/CTPB	PA5	PAPU PAWU PAS1	ST	CMOS	General purpose I/O. Register enabled pull-up and wake-up
	OPA0P	PAS1	AN	—	Operational amplifier 0 positive input
	CTPB	PAS1	—	CMOS	CTM inverting output
PA6/OPA1P/STPB	PA6	PAPU PAWU PAS1	ST	CMOS	General purpose I/O. Register enabled pull-up and wake-up
	OPA1P	PAS1	AN	—	Operational amplifier 1 positive input
	STPB	PAS1	—	CMOS	STM inverting output
PA7/SDO/TX	PA7	PAPU PAWU PAS1	ST	CMOS	General purpose I/O. Register enabled pull-up and wake-up
	SDO	PAS1	—	CMOS	SPI serial data output
	TX	PAS1	—	CMOS	UART TX serial data output
PB0/AN0	PB0	PBPU PBS0	ST	CMOS	General purpose I/O. Register enabled pull-up
	AN0	PBS0	AN	—	A/D Converter external input 0
PB1/AN1/VREF	PB1	PBPU PBS0	ST	CMOS	General purpose I/O. Register enabled pull-up
	AN1	PBS0	AN	—	A/D Converter external input 1
	VREF	PBS0	AN	—	A/D Converter external reference voltage input
PB2/AN2/STPI	PB2	PBPU PBS0	ST	CMOS	General purpose I/O. Register enabled pull-up
	AN2	PBS0	AN	—	A/D Converter external input 2
	STPI	PBS0	ST	—	STM capture input
PB3/AN3	PB3	PBPU PBS0	ST	CMOS	General purpose I/O. Register enabled pull-up
	AN3	PBS0	AN	—	A/D Converter external input 3
PB4/AN4	PB4	PBPU PBS1	ST	CMOS	General purpose I/O. Register enabled pull-up
	AN4	PBS1	AN	—	A/D Converter external input 4
PB5/AN5	PB5	PBPU PBS1	ST	CMOS	General purpose I/O. Register enabled pull-up
	AN5	PBS1	AN	—	A/D Converter external input 5
PB6/AN6/INT1	PB6	PBPU PBS1	ST	CMOS	General purpose I/O. Register enabled pull-up
	AN6	PBS1	AN	—	A/D Converter external input 6
	INT1	PBS1 INTEG INTC0	ST	—	External interrupt 1 input

Pin Name	Function	OPT	I/T	O/T	Description
PB7/AN7	PB7	PBPU PBS1	ST	CMOS	General purpose I/O. Register enabled pull-up
	AN7	PBS1	AN	—	A/D Converter external input 7
PC0/AN8/ $\overline{\text{SCS}}$	PC0	PCPU PCS0	ST	CMOS	General purpose I/O. Register enabled pull-up
	AN8	PCS0	AN	—	A/D Converter external input 8
	$\overline{\text{SCS}}$	PCS0 IFS	ST	CMOS	SPI slave select
PC1/AN9/SCK/SCL	PC1	PCPU PCS0	ST	CMOS	General purpose I/O. Register enabled pull-up
	AN9	PCS0	AN	—	A/D Converter external input 9
	SCK	PCS0 IFS	ST	CMOS	SPI serial clock
	SCL	PCS0 IFS	ST	NMOS	I <sup>2</sup> C clock line
PC2/SDI/SDA/RX	PC2	PCPU PCS0	ST	CMOS	General purpose I/O. Register enabled pull-up
	SDI	PCS0 IFS	ST	—	SPI serial data input
	SDA	PCS0 IFS	ST	NMOS	I <sup>2</sup> C data line
	RX	PCS0 IFS	ST	—	UART RX serial data input
PC3/SCOM0/SCK/SCL	PC3	PCPU PCS0	ST	CMOS	General purpose I/O. Register enabled pull-up
	SCOM0	PCS0	—	AN	Software LCD COM output
	SCK	PCS0 IFS	ST	CMOS	SPI serial clock
	SCL	PCS0 IFS	ST	NMOS	I <sup>2</sup> C clock line
PC4/SCOM1/ $\overline{\text{SCS}}$	PC4	PCPU PCS1	ST	CMOS	General purpose I/O. Register enabled pull-up
	SCOM1	PCS1	—	AN	Software LCD COM output
	$\overline{\text{SCS}}$	PCS1 IFS	ST	CMOS	SPI slave select
PC5/SCOM2	PC5	PCPU PCS1	ST	CMOS	General purpose I/O. Register enabled pull-up
	SCOM2	PCS1	—	AN	Software LCD COM output
PC6/SCOM3	PC6	PCPU PCS1	ST	CMOS	General purpose I/O. Register enabled pull-up
	SCOM3	PCS1	—	AN	Software LCD COM output
OPA0N	OPA0N	—	AN	—	Operational amplifier 0 negative input
OPA1N	OPA1N	—	AN	—	Operational amplifier 1 negative input
OPAE	OPAE	—	—	AN	Operational amplifier output
VDD	VDD	—	PWR	—	Positive power supply
VSS	VSS	—	PWR	—	Negative power supply, ground

Legend: I/T: Input type;

OPT: Optional by register option;

ST: Schmitt Trigger input;

NMOS: NMOS output;

O/T: Output type;

PWR: Power;

CMOS: CMOS output;

AN: Analog signal.

## Absolute Maximum Ratings

Supply Voltage .....	$V_{SS}-0.3V$ to $6.0V$
Input Voltage .....	$V_{SS}-0.3V$ to $V_{DD}+0.3V$
Storage Temperature.....	$-50^{\circ}C$ to $125^{\circ}C$
Operating Temperature.....	$-40^{\circ}C$ to $85^{\circ}C$
$I_{OH}$ Total .....	$-80mA$
$I_{OL}$ Total .....	$80mA$
Total Power Dissipation .....	$500mW$

Note: These are stress ratings only. Stresses exceeding the range specified under “Absolute Maximum Ratings” may cause substantial damage to the device. Functional operation of the device at other conditions beyond those listed in the specification is not implied and prolonged exposure to extreme conditions may affect device reliability.

## D.C. Characteristics

For data in the following tables, note that factors such as oscillator type, operating voltage, operating frequency, pin load conditions, temperature and program instruction type, etc., can all exert an influence on the measured values.

### Operating Voltage Characteristics

 $T_a = -40^{\circ}C \sim 85^{\circ}C$ 

Symbol	Parameter	Test Conditions	Min.	Typ.	Max.	Unit
$V_{DD}$	Operating Voltage – HIRC	$f_{SYS} = f_{HIRC} = 8MHz$	2.2	—	5.5	V
	Operating Voltage – LIRC	$f_{SYS} = f_{LIRC} = 32kHz$	2.2	—	5.5	V

### Operating Current Characteristics

 $T_a = -40^{\circ}C \sim 85^{\circ}C$ 

Symbol	Operating Mode	Test Conditions		Min.	Typ.	Max.	Unit
		$V_{DD}$	Conditions				
$I_{DD}$	SLOW Mode – LIRC	5V	$f_{SYS} = 32kHz$ , OPA0/1 enable	—	0.6	1.2	mA
	FAST Mode – HIRC	5V	$f_{SYS} = 8MHz$ , OPA0/1 enable	—	2.2	3.6	mA

Note: When using the characteristic table data, the following notes should be taken into consideration:

1. Any digital inputs are setup in a non-floating condition.
2. All measurements are taken under conditions of no load and with all peripherals in an off state.
3. There are no DC current paths.
4. All Operating Current values are measured using a continuous NOP instruction program loop.

### Standby Current Characteristics

 $T_a = 25^{\circ}C$ , unless otherwise specified

Symbol	Standby Mode	Test Conditions		Min.	Typ.	Max.	Max. @85°C	Unit
		$V_{DD}$	Conditions					
$I_{STB}$	SLEEP Mode	5V	WDT on	—	0.6	1.2	1.2	mA
	IDLE0 Mode – LIRC	5V	$f_{SUB}$ on	—	0.6	1.2	1.2	mA
	IDLE1 Mode – HIRC	5V	$f_{SUB}$ on, $f_{SYS} = 8MHz$	—	1.2	2.0	2.0	mA

Note: When using the characteristic table data, the following notes should be taken into consideration:

1. Any digital inputs are setup in a non-floating condition.
2. All measurements are taken under conditions of no load and with all peripherals in an off state.
3. There are no DC current paths.
4. All Standby Current values are taken after a HALT instruction execution thus stopping all instruction execution.

## A.C. Characteristics

For data in the following tables, note that factors such as oscillator type, operating voltage, operating frequency and temperature etc., can all exert an influence on the measured values.

### High Speed Internal Oscillator – HIRC – Frequency Accuracy

During the program writing operation the writer will trim the HIRC oscillator at a user selected HIRC frequency and user selected voltage of either 3V or 5V.

Symbol	Parameter	Test Conditions		Min.	Typ.	Max.	Unit
		V <sub>DD</sub>	Temp.				
f <sub>HIRC</sub>	8MHz Writer Trimmed HIRC Frequency	3V/5V	25°C	-1%	8	+1%	MHz
			-40°C~85°C	-2%	8	+2%	
		2.2V~5.5V	25°C	-2.5%	8	+2.5%	
			-40°C~85°C	-3%	8	+3%	

- Note: 1. The 3V/5V values for V<sub>DD</sub> are provided as these are the two selectable fixed voltages at which the HIRC frequency is trimmed by the writer.
2. The row below the 3V/5V trim voltage row is provided to show the values for the full V<sub>DD</sub> range operating voltage. It is recommended that the trim voltage is fixed at 3V for application voltage ranges from 2.2V to 3.6V and fixed at 5V for application voltage ranges from 3.3V to 5.5V.
3. The minimum and maximum tolerance values provided in the table are only for the frequency at which the writer trims the HIRC oscillator. After trimming at this chosen specific frequency any change in HIRC oscillator frequency using the oscillator register control bits by the application program will give a frequency tolerance to within ±20%.

### Low Speed Internal Oscillator Characteristics – LIRC

Symbol	Parameter	Test Conditions		Min.	Typ.	Max.	Unit
		V <sub>DD</sub>	Temp.				
f <sub>LIRC</sub>	LIRC Frequency	5V	25°C	25.6	32.0	38.4	kHz
		2.2V~5.5V	25°C	12.8	32.0	41.6	
			-40°C~85°C	8	32	60	kHz
t <sub>START</sub>	LIRC Start Up Time	—	25°C	—	—	100	μs

### Operating Frequency Characteristic Curves

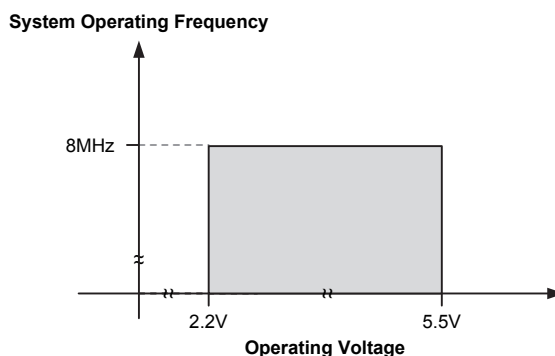

### System Start Up Time Characteristics

Ta=-40°C~85°C

Symbol	Parameter	Test Conditions		Min.	Typ.	Max.	Unit
		V <sub>DD</sub>	Conditions				
t <sub>SST</sub>	System Start-up Time (Wake-up from condition where f <sub>SYS</sub> is off)	—	f <sub>SYS</sub> =f <sub>H</sub> ~f <sub>H</sub> /64, f <sub>H</sub> =f <sub>HIRC</sub>	—	16	—	t <sub>HIRC</sub>
		—	f <sub>SYS</sub> =f <sub>SUB</sub> =f <sub>LIRC</sub>	—	2	—	t <sub>LIRC</sub>
	System Start-up Time (Wake-up from condition where f <sub>SYS</sub> is on)	—	f <sub>SYS</sub> =f <sub>H</sub> ~f <sub>H</sub> /64, f <sub>H</sub> =f <sub>HIRC</sub>	—	2	—	t <sub>H</sub>
		—	f <sub>SYS</sub> =f <sub>SUB</sub> =f <sub>LIRC</sub>	—	2	—	t <sub>SUB</sub>
	System Speed Switch Time (FAST to SLOW Mode or SLOW to FAST Mode)	—	f <sub>HIRC</sub> switches from off → on	—	16	—	t <sub>HIRC</sub>
t <sub>RSTD</sub>	System Reset Delay Time (Reset source from Power-on Reset or LVR Hardware Reset)	—	RR <sub>POR</sub> =5V/ms	8.3	16.7	50.0	ms
	System Reset Delay Time (LVR/WDT Software Reset)	—	—				
	System Reset Delay Time (Reset source from WDT Overflow)	—	—	8.3	16.7	50.0	ms
t <sub>SRESET</sub>	Minimum Software Reset Width to Reset	—	—	45	90	375	μs

- Note: 1. For the System Start-up time values, whether f<sub>SYS</sub> is on or off depends upon the mode type and the chosen f<sub>SYS</sub> system oscillator. Details are provided in the System Operating Modes section.
2. The time units, shown by the symbol t<sub>HIRC</sub> etc. are the inverse of the corresponding frequency values as provided in the frequency tables. For example t<sub>HIRC</sub>=1/f<sub>HIRC</sub>, t<sub>SYS</sub>=1/f<sub>SYS</sub> etc.
3. If the LIRC is used as the system clock and if it is off when in the SLEEP Mode, then an additional LIRC start up time, t<sub>START</sub>, as provided in the LIRC frequency table, must be added to the t<sub>SST</sub> time in the table above.
4. The System Speed Switch Time is effectively the time taken for the newly activated oscillator to start up.

### Input/Output Characteristics

Ta=-40°C~85°C

Symbol	Parameter	Test Conditions		Min.	Typ.	Max.	Unit
		V <sub>DD</sub>	Conditions				
V <sub>IL</sub>	Input Low Voltage for I/O Ports or Input Pins	5V	—	0	—	1.5	V
		—	—	0	—	0.2V <sub>DD</sub>	
V <sub>IH</sub>	Input High Voltage for I/O Ports or Input Pins	5V	—	3.5	—	5.0	V
		—	—	0.8V <sub>DD</sub>	—	V <sub>DD</sub>	
I <sub>OL</sub>	Sink Current for I/O Ports	3V	V <sub>OL</sub> =0.1V <sub>DD</sub>	16	32	—	mA
		5V		32	65	—	
I <sub>OH</sub>	Source Current for I/O Ports	3V	V <sub>OH</sub> =0.9V <sub>DD</sub>	-4	-8	—	mA
		5V		-8	-16	—	
R <sub>PH</sub>	Pull-high Resistance for I/O Ports <sup>(Note)</sup>	3V	—	20	60	100	kΩ
		5V	—	10	30	50	
I <sub>LEAK</sub>	Input Leakage Current	5V	V <sub>IN</sub> =V <sub>DD</sub> or V <sub>IN</sub> =V <sub>SS</sub>	—	—	±1	μA
t <sub>TCK</sub>	TM Clock Input Minimum Pulse Width	—	—	0.3	—	—	μs
t <sub>TPI</sub>	TM Capture Input Minimum Pulse Width	—	—	0.3	—	—	μs
t <sub>INT</sub>	External Interrupt Input Minimum Pulse Width	—	—	0.3	—	—	μs

Note: The R<sub>PH</sub> internal pull high resistance value is calculated by connecting to ground and enabling the input pin with a pull-high resistor and then measuring the pin current at the specified supply voltage level. Dividing the voltage by this measured current provides the R<sub>PH</sub> value.

## Memory Characteristics

Ta=-40°C~85°C, unless otherwise specified

Symbol	Parameter	Test Conditions		Min.	Typ.	Max.	Unit
		V <sub>DD</sub>	Conditions				
<b>Flash Program / Emulated EEPROM Memory</b>							
V <sub>DD</sub>	Operating Voltage for Read	—	—	2.2	—	5.5	V
	Operating Voltage for Erase/Write	—	—	4.5	5.0	5.5	
t <sub>DEW</sub>	Erase / Write Time – Flash Program Memory	5V	—	—	2	3	ms
	Erase / Write Cycle Time – Emulated EEPROM Memory	—	EWRTS[1:0]=00B	—	2	3	
		—	EWRTS[1:0]=01B	—	4	6	
		—	EWRTS[1:0]=10B	—	8	12	
—	EWRTS[1:0]=11B	—	16	24			
I <sub>DDPGM</sub>	Programming / Erase Current on V <sub>DD</sub>	5V	—	—	—	5.0	mA
E <sub>P</sub>	Cell Endurance	—	—	10K	—	—	E/W
t <sub>RETD</sub>	ROM Data Retention time	—	Ta=25°C	—	40	—	Year
<b>RAM Data Memory</b>							
V <sub>DD</sub>	Operating Voltage for Read/Write	—	—	V <sub>DDmin</sub>	—	V <sub>DDmax</sub>	V
V <sub>DR</sub>	RAM Data Retention Voltage	—	Device in SLEEP Mode	1.0	—	—	V

Note: The Emulated EEPROM erase/write operation can only be executed when the f<sub>sys</sub> clock frequency is equal to or greater than 2MHz.

## LVR Electrical Characteristics

Ta=-40°C~85°C

Symbol	Parameter	Test Conditions		Min.	Typ.	Max.	Unit
		V <sub>DD</sub>	Conditions				
V <sub>LVR</sub>	Low Voltage Reset Voltage	—	LVR enable	-5%	2.1	+5%	V
t <sub>LVR</sub>	Minimum Low Voltage Width to Reset	—	—	120	240	480	μs
I <sub>LVR</sub>	Additional Current for LVR Enable	5V	—	—	—	90	μA

## A/D Converter Electrical Characteristics

Ta=-40°C~85°C

Symbol	Parameter	Test Conditions		Min.	Typ.	Max.	Unit
		V <sub>DD</sub>	Conditions				
V <sub>DD</sub>	A/D Converter Operating Voltage	—	—	V <sub>LVR</sub>	—	5.5	V
V <sub>ADI</sub>	A/D Converter Input Voltage	—	—	0	—	V <sub>REF</sub>	V
V <sub>REF</sub>	A/D Converter Reference Voltage	—	—	2	—	V <sub>DD</sub>	V
N <sub>R</sub>	A/D Converter Resolution	—	—	—	—	12	Bit
DNL	A/D Converter Differential Non-linearity	—	V <sub>REF</sub> =V <sub>DD</sub> , t <sub>ADCK</sub> =0.5μs	-3	—	3	LSB
INL	A/D Converter Integral Non-linearity	—	V <sub>REF</sub> =V <sub>DD</sub> , t <sub>ADCK</sub> =0.5μs	-4	—	4	LSB
I <sub>ADC</sub>	Additional Current for A/D Converter Enable	2.2V	No load, t <sub>ADCK</sub> =0.5μs	—	300	420	μA
		3V		—	340	500	μA
		5V		—	500	700	μA
t <sub>ADCK</sub>	A/D Converter Clock Period	—	—	0.5	—	10.0	μs
t <sub>ON2ST</sub>	A/D Converter On-to-Start Time	—	—	4	—	—	μs
t <sub>ADS</sub>	A/D Sampling Time	—	—	—	4	—	t <sub>ADCK</sub>

Symbol	Parameter	Test Conditions		Min.	Typ.	Max.	Unit
		V <sub>DD</sub>	Conditions				
t <sub>ADC</sub>	A/D Conversion Time (Including A/D Sample and Hold Time)	—	—	—	16	—	t <sub>ADCK</sub>
GERR	A/D Conversion Gain Error	—	V <sub>REF</sub> =V <sub>DD</sub>	-4	—	4	LSB
OSRR	A/D Conversion Offset Error	—	V <sub>REF</sub> =V <sub>DD</sub>	-4	—	4	LSB

## D/A Converter Electrical Characteristics

Ta=-40°C~85°C

Symbol	Parameter	Test Conditions		Min.	Typ.	Max.	Unit
		V <sub>DD</sub>	Conditions				
V <sub>DACO</sub>	D/A Converter Output Voltage Range	—	—	V <sub>SS</sub>	—	V <sub>DD</sub>	V
I <sub>DAC</sub>	Additional Current for D/A Converter 0 Enable	5V	—	—	600	800	μA
	Additional Current for D/A Converter 1 Enable	5V	—	—	500	600	μA
t <sub>ST</sub>	D/A Converter Settling Time	5V	C <sub>LOAD</sub> =50pF	—	—	5	μs
DNL	D/A Converter 0 Differential Non-linearity	5V	V <sub>REF</sub> =V <sub>DD</sub>	—	±6	±12	LSB
	D/A Converter 1 Differential Non-linearity			—	±4	±10	
INL	D/A Converter 0 Integral Non-linearity	5V	V <sub>REF</sub> =V <sub>DD</sub>	—	±8	±16	LSB
	D/A Converter 1 Integral Non-linearity			—	±6	±12	
R <sub>o</sub>	D/A Converter 0/1 R2R Output Resistor	5V	—	—	13	—	kΩ

## Operational Amplifier Electrical Characteristics

Ta=-40°C~85°C, unless otherwise specified

Symbol	Parameter	Test Conditions		Min.	Typ.	Max.	Unit
		V <sub>DD</sub>	Conditions				
I <sub>OPA</sub>	Additional Current for Each OPA	5V	No load	—	300	600	μA
V <sub>OS</sub>	Input Offset Voltage	5V	OPA0/1 without calibration Ta=25°C	-7	5	7	mV
		5V	OPA2 without calibration (OOF[5:0]=100000B)	-15	—	15	mV
		5V	OPA2 with calibration	-2	—	2	mV
V <sub>CM</sub>	Common Mode Voltage Range	5V	—	V <sub>SS</sub>	—	V <sub>DD</sub> -1.4	V
I <sub>SINK</sub>	Output Sink Current	3V	V <sub>OL</sub> =0.3V	0.7	1.2	—	mA
		5V	V <sub>OL</sub> =0.5V	1.6	2.8	—	mA

## Software Controlled LCD Driver Electrical Characteristics

Ta=-40°C~85°C

Symbol	Parameter	Test Conditions		Min.	Typ.	Max.	Unit
		V <sub>DD</sub>	Conditions				
I <sub>BIAS</sub>	V <sub>DD</sub> /2 Bias Current for LCD	3V	ISEL[1:0]=00B	10.5	15.0	19.5	μA
		5V		17.5	25.0	32.5	
		3V	ISEL[1:0]=01B	21	30	39	
		5V		35	50	65	
		3V	ISEL[1:0]=10B	42	60	78	
		5V		70	100	130	
		3V	ISEL[1:0]=11B	82.6	118.0	153.4	
		5V		140	200	260	
V <sub>SCOM</sub>	V <sub>DD</sub> /2 Voltage for LCD COM Ports	2.2V~5.5V	No load	0.475 V <sub>DD</sub>	0.500 V <sub>DD</sub>	0.525 V <sub>DD</sub>	V

## Power-on Reset Characteristics

Ta=-40°C~85°C

Symbol	Parameter	Test Conditions		Min.	Typ.	Max.	Unit
		V <sub>DD</sub>	Conditions				
V <sub>POR</sub>	V <sub>DD</sub> Start Voltage to Ensure Power-on Reset	—	—	—	—	100	mV
RR <sub>POR</sub>	V <sub>DD</sub> Rising Rate to Ensure Power-on Reset	—	—	0.035	—	—	V/ms
t <sub>POR</sub>	Minimum Time for V <sub>DD</sub> Stays at V <sub>POR</sub> to Ensure Power-on Reset	—	—	1	—	—	ms

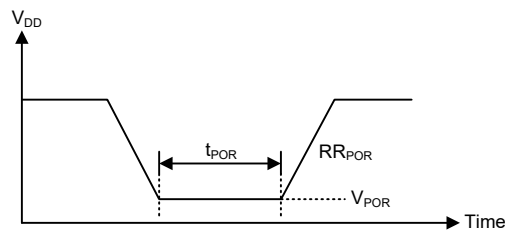

## System Architecture

A key factor in the high-performance features of the Holtek range of microcontrollers is attributed to their internal system architecture. The device takes advantage of the usual features found within RISC microcontrollers providing increased speed of operation and Periodic performance. The pipelining scheme is implemented in such a way that instruction fetching and instruction execution are overlapped, hence instructions are effectively executed in one cycle, with the exception of branch or call instructions. An 8-bit wide ALU is used in practically all instruction set operations, which carries out arithmetic operations, logic operations, rotation, increment, decrement, branch decisions, etc. The internal data path is simplified by moving data through the Accumulator and the ALU. Certain internal registers are implemented in the Data Memory and can be directly or indirectly addressed. The simple addressing methods of these registers along with additional architectural features ensure that a minimum of external components is required to provide a functional I/O and A/D control system with maximum reliability and flexibility. This makes the device suitable for low-cost, high-volume production for controller applications.

### Clocking and Pipelining

The main system clock, derived from either an HIRC or LIRC oscillator is subdivided into four internally generated non-overlapping clocks, T1~T4. The Program Counter is incremented at the beginning of the T1 clock during which time a new instruction is fetched. The remaining T2~T4 clocks carry out the decoding and execution functions. In this way, one T1~T4 clock cycle forms one instruction cycle. Although the fetching and execution of instructions takes place in consecutive instruction cycles, the pipelining structure of the microcontroller ensures that instructions are effectively executed in one instruction cycle. The exception to this are instructions where the contents of the Program Counter are changed, such as subroutine calls or jumps, in which case the instruction will take one more instruction cycle to execute.

For instructions involving branches, such as jump or call instructions, two machine cycles are required to complete instruction execution. An extra cycle is required as the program takes one cycle to first obtain the actual jump or call address and then another cycle to actually execute the branch. The requirement for this extra cycle should be taken into account by programmers in timing sensitive applications.

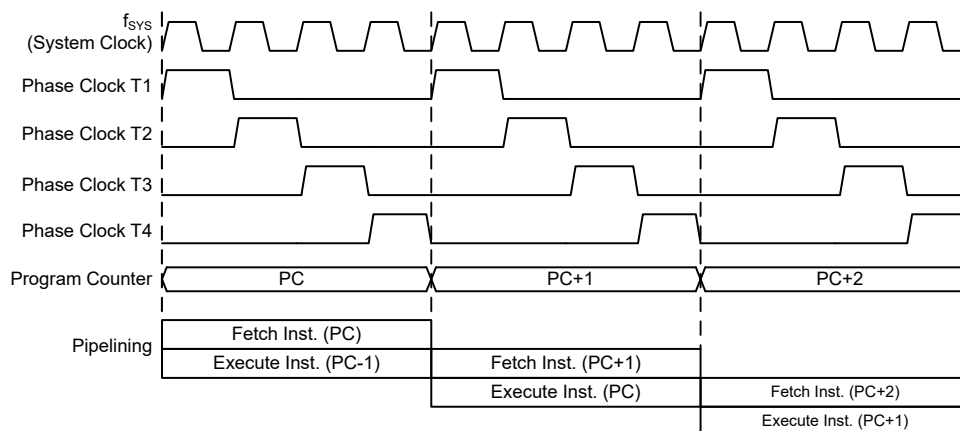

**System Clocking and Pipelining**

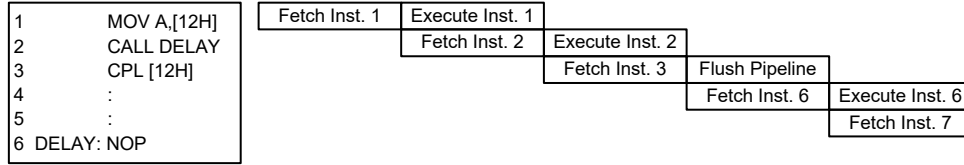

**Instruction Fetching**

**Program Counter**

During program execution, the Program Counter is used to keep track of the address of the next instruction to be executed. It is automatically incremented by one each time an instruction is executed except for instructions, such as “JMP” or “CALL” that demand a jump to a non-consecutive Program Memory address. Only the lower 8 bits, known as the Program Counter Low Register, are directly addressable by the application program.

When executing instructions requiring jumps to non-consecutive addresses such as a jump instruction, a subroutine call, interrupt or reset, etc., the microcontroller manages program control by loading the required address into the Program Counter. For conditional skip instructions, once the condition has been met, the next instruction, which has already been fetched during the present instruction execution, is discarded and a dummy cycle takes its place while the correct instruction is obtained.

Program Counter	
Program Counter High Byte	PCL Register
PC11~PC8	PCL7~PCL0

**Program Counter**

The lower byte of the Program Counter, known as the Program Counter Low register or PCL, is available for program control and is a readable and writeable register. By transferring data directly into this register, a short program jump can be executed directly; however, as only this low byte is available for manipulation, the jumps are limited to the present page of memory that is 256 locations. When such program jumps are executed it should also be noted that a dummy cycle will be inserted. Manipulating the PCL register may cause program branching, so an extra cycle is needed to pre-fetch.

**Stack**

This is a special part of the memory which is used to save the contents of the Program Counter only. The stack is organized into 6 levels and neither part of the data nor part of the program space, and is neither readable nor writeable. The activated level is indexed by the Stack Pointer, and is neither readable nor writeable. At a subroutine call or interrupt acknowledge signal, the contents of the Program Counter are pushed onto the stack. At the end of a subroutine or an interrupt routine, signaled by a return instruction, RET or RETI, the Program Counter is restored to its previous value from the stack. After a device reset, the Stack Pointer will point to the top of the stack.

If the stack is full and an enabled interrupt takes place, the interrupt request flag will be recorded but the acknowledge signal will be inhibited. When the Stack Pointer is decremented, by RET or RETI, the interrupt will be serviced. This feature prevents stack overflow allowing the programmer to use the structure more easily. However, when the stack is full, a CALL subroutine instruction can still be executed which will result in a stack overflow. Precautions should be taken to avoid such cases which might cause unpredictable program branching.

If the stack is overflow, the first Program Counter save in the stack will be lost.

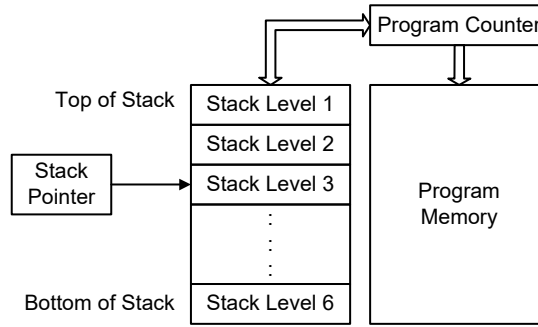

### Arithmetic and Logic Unit – ALU

The arithmetic-logic unit or ALU is a critical area of the microcontroller that carries out arithmetic and logic operations of the instruction set. Connected to the main microcontroller data bus, the ALU receives related instruction codes and performs the required arithmetic or logical operations after which the result will be placed in the specified register. As these ALU calculation or operations may result in carry, borrow or other status changes, the status register will be correspondingly updated to reflect these changes. The ALU supports the following functions:

- Arithmetic operations:  
ADD, ADDM, ADC, ADCM, SUB, SUBM, SBC, SBCM, DAA,
- Logic operations:  
AND, OR, XOR, ANDM, ORM, XORM, CPL, CPLA,
- Rotation:  
RRA, RR, RRCA, RRC, RLA, RL, RLCA, RLC,
- Increment and Decrement:  
INCA, INC, DECA, DEC,
- Branch decision:  
JMP, SZ, SZA, SNZ, SIZ, SDZ, SIZA, SDZA, CALL, RET, RETI

### Flash Program Memory

The Program Memory is the location where the user code or program is stored. For the device the Program Memory is Flash type, which means it can be programmed and re-programmed a large number of times, allowing the user the convenience of code modification on the same device. By using the appropriate programming tools, the Flash device offers users the flexibility to conveniently debug and develop their applications while also offering a means of field programming and updating.

#### Structure

The Program Memory has a capacity of 4K×15 bits. The Program Memory is addressed by the Program Counter and also contains data, table information and interrupt entries. Table data, which can be setup in any location within the Program Memory, is addressed by a separate table pointer register.

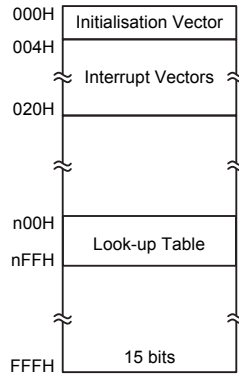

**Program Memory Structure**

**Special Vectors**

Within the Program Memory, certain locations are reserved for the reset and interrupts. The location 000H is reserved for use by the device reset for program initialisation. After a device reset is initiated, the program will jump to this location and begin execution.

**Look-up Table**

Any location within the Program Memory can be defined as a look-up table where programmers can store fixed data. To use the look-up table, the table pointer must first be setup by placing the address of the look up data to be retrieved in the table pointer registers, TBLP and TBHP. These registers define the total address of the look-up table.

After setting up the table pointer, the table data can be retrieved from the Program Memory using the “TABRD [m]” or “TABRDL [m]” instructions, respectively. When the instruction is executed, the lower order table byte from the Program Memory will be transferred to the user defined Data Memory register [m] as specified in the instruction. The higher order table data byte from the Program Memory will be transferred to the TBLH special register. Any unused bits in this transferred higher order byte will be read as 0.

The accompanying diagram illustrates the addressing data flow of the look-up table.

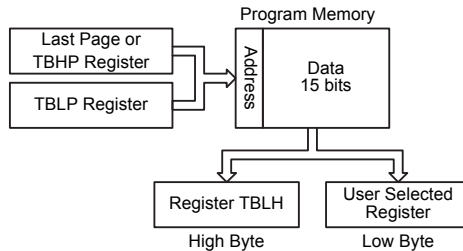

**Table Program Example**

The following example shows how the table pointer and table data is defined and retrieved from the microcontroller. This example uses raw table data located in the Program Memory which is stored there using the ORG statement. The value at this ORG statement is “0F00H” which refers to the start address of the last page within the 4K words Program Memory of the microcontroller. The table pointer low byte register is setup here to have an initial value of “06H”. This will ensure that the first data read from the data table will be at the Program Memory address “0F06H” or 6 locations after the start of the last page. Note that the value for the table pointer is referenced to the specified address pointed by the TBLP and TBHP registers if the “TABRD [m]” instruction is being used. The

high byte of the table data which in this case is equal to zero will be transferred to the TBLH register automatically when the “TABRD [m]” instruction is executed.

Because the TBLH register is a read-only register and cannot be restored, care should be taken to ensure its protection if both the main routine and Interrupt Service Routine use table read instructions. If using the table read instructions, the Interrupt Service Routines may change the value of the TBLH and subsequently cause errors if used again by the main routine. As a rule it is recommended that simultaneous use of the table read instructions should be avoided. However, in situations where simultaneous use cannot be avoided, the interrupts should be disabled prior to the execution of any main routine table-read instructions. Note that all table related instructions require two instruction cycles to complete their operation.

**Table Read Program Example**

```

tempreg1 db? ; temporary register #1
tempreg2 db? ; temporary register #2
:
:
mov a,06h ; initialise low table pointer - note that this address is referenced
mov tblp,a ; to the last page or the page that tblp pointed
mov a,0Fh ; initialise high table pointer
mov tbhp,a ; it is not necessary to set tbhp if executing tabrdl
:
:
tabrd tempreg1 ; transfers value in table referenced by table pointer
; data at program memory address “0F06H” transferred to tempreg1 and TBLH
dec tblp ; reduce value of table pointer by one
tabrd tempreg2 ; transfers value in table referenced by table pointer
; data at program memory address “0F05H” transferred to tempreg2 and TBLH
; in this example the data “1AH” is transferred to
; tempreg1 and data “0FH” to tempreg2
; the value “00H” will be transferred to the high byte register TBLH
:
:
org 0F00h ; set initial address of last page
dc 00Ah,00Bh,00Ch,00Dh,00Eh,00Fh,01Ah,01Bh

```

**In Circuit Programming – ICP**

The provision of Flash type Program Memory provides the user with a means of convenient and easy upgrades and modifications to their programs on the same device.

As an additional convenience, Holtek has provided a means of programming the microcontroller in-circuit using a 4-pin interface. This provides manufacturers with the possibility of manufacturing their circuit boards complete with a programmed or un-programmed microcontroller, and then programming or upgrading the program at a later stage. This enables product manufacturers to easily keep their manufactured products supplied with the latest program releases without removal and re-insertion of the device.

Holtek Writer Pins	MCU Programming Pins	Pin Description
ICPDA	PA0	Programming Serial Data/Address
ICPCK	PA2	Programming Clock
VDD	VDD	Power Supply
VSS	VSS	Ground

The Program Memory can be programmed serially in-circuit using this 4-wire interface. Data is downloaded and uploaded serially on a single pin with an additional line for the clock. Two additional lines are required for the power supply. The technical details regarding the in-circuit programming of the device is beyond the scope of this document and will be supplied in supplementary literature.

During the programming process, the user must take care of the ICPDA and ICPCCK pins for data and clock programming purposes to ensure that no other outputs are connected to these two pins.

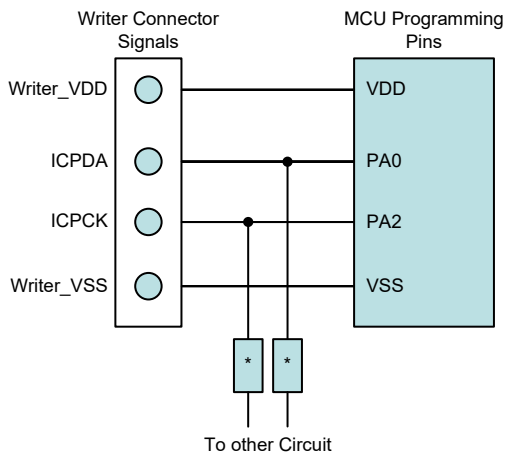

Note: \* may be resistor or capacitor. The resistance of \* must be greater than 1kΩ or the capacitance of \* must be less than 1nF.

### On-Chip Debug Support – OCDS

There is an EV chip named HT45V5Q-3 which is used to emulate the HT45F5Q-3 device. This EV chip device also provides an “On-Chip Debug” function to debug the real MCU device during the development process. The EV chip and the real MCU device are almost functionally compatible except for “On-Chip Debug” function. Users can use the EV chip device to emulate the real chip device behavior by connecting the OCSDA and OCDSCK pins to the Holtek HT-IDE development tools. The OCSDA pin is the OCDS Data/Address input/output pin while the OCDSCK pin is the OCDS clock input pin. When users use the EV chip for debugging, other functions which are shared with the OCSDA and OCDSCK pins in the device will have no effect in the EV chip. However, the two OCDS pins which are pin-shared with the ICP programming pins are still used as the Flash Memory programming pins for ICP. For more detailed OCDS information, refer to the corresponding document named “Holtek e-Link for 8-bit MCU OCDS User’s Guide”.

Holtek e-Link Pins	EV Chip Pins	Pin Description
OCSDA	OCSDA	On-Chip Debug Support Data/Address input/output
OCDSCK	OCDSCK	On-Chip Debug Support Clock input
VDD	VDD	Power Supply
VSS	VSS	Ground

## Data Memory

The Data Memory is a volatile area of 8-bit wide RAM internal memory and is the location where temporary information is stored.

### Structure

Divided into two types, the first of these is an area of RAM, known as the Special Function Data Memory. Here are located registers which are necessary for correct operation of the device. Many of these registers can be read from and written to directly under program control, however, some remain protected from user manipulation. The second area of Data Memory is known as the General Purpose Data Memory, which is reserved for general purpose use. All locations within this area are read and write accessible under program control.

The overall Data Memory is subdivided into two banks, which are Bank 0 and Bank 1 and implemented in 8-bit wide Memory. Switching between the different Data Memory banks is achieved by setting the Bank Pointer to the correct value. The address range of the Special Purpose Data Memory for the device is from 00H to 7FH in Bank 0 while the General Purpose Data Memory address range is from 80H to FFH in Bank 0 and Bank 1.

Special Purpose Data Memory	General Purpose Data Memory	
Located Banks	Capacity	Bank: Address
Bank 0	256×8	Bank 0: 80H~FFH Bank 1: 80H~FFH

**Data Memory Summary**

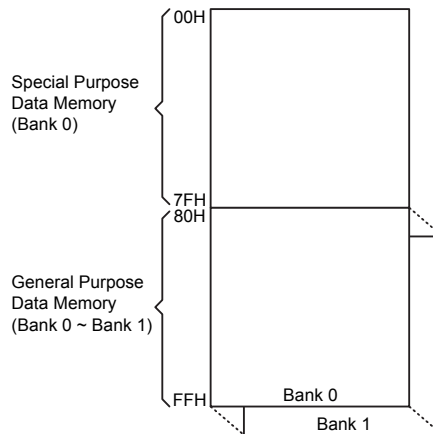

**Data Memory Structure**

### General Purpose Data Memory

All microcontroller programs require an area of read/write memory where temporary data can be stored and retrieved for use later. It is this area of RAM memory that is known as General Purpose Data Memory. This area of Data Memory is fully accessible by the user programming for both reading and writing operations. By using the bit operation instructions individual bits can be set or reset under program control giving the user a large range of flexibility for bit manipulation in the Data Memory.

### Special Purpose Data Memory

This area of Data Memory is where registers, necessary for the correct operation of the microcontroller, are stored. Most of the registers are both readable and writeable but some are protected and are readable only, the details of which are located under the relevant Special Function Register section. Note that for locations that are unused, any read instruction to these addresses will return the value “00H”.

Bank 0		Bank 0	
00H	IAR0	30H	ECR
01H	MP0	31H	EAR
02H	IAR1	32H	ED0L
03H	MP1	33H	ED0H
04H	BP	34H	ED1L
05H	ACC	35H	ED1H
06H	PCL	36H	ED2L
07H	TBLP	37H	ED2H
08H	TBLH	38H	ED3L
09H	TBHP	39H	ED3H
0AH	STATUS	3AH	LVRC
0BH		3BH	WDTL
0CH		3CH	SCC
0DH		3DH	HIRCC
0EH		3EH	PSCR
0FH	RSTFC	3FH	STMC0
10H	SADOL	40H	STMC1
11H	SAD0H	41H	STMDL
12H	SADC0	42H	STMDH
13H	SADC1	43H	STMAL
14H	PA	44H	STMAH
15H	PAC	45H	TB0C
16H	PAPU	46H	TB1C
17H	PAWU	47H	SIMC0
18H	IECC	48H	SIMC1/UUCR1
19H	PB	49H	SIMD/UTXR_RXR
1AH	PBC	4AH	SIMA/SIMC2/UUCR2
1BH	PBPU	4BH	SIMTOC/UBRG
1CH	PC	4CH	UUSR
1DH	PCC	4DH	INTC0
1EH	PCPU	4EH	INTC1
1FH	SCOMC	4FH	INTC2
20H	DA0L	50H	MF10
21H	DA0H	51H	MF11
22H	DA1L	52H	INTEG
23H	DA1H	53H	IFS
24H	DAOPC	54H	PAS0
25H	OPVOS	55H	PAS1
26H	CRCCR	56H	PBS0
27H	CRCIN	57H	PBS1
28H	CRCDL	58H	PCS0
29H	CRCDH	59H	PCS1
2AH	CTMC0	.....	
2BH	CTMC1	.....	
2CH	CTMDL	.....	
2DH	CTMDH	.....	
2EH	CTMAL	.....	
2FH	CTMAH	7FH	

☐ : Unused, read as 00H

### Special Purpose Data Memory

## Special Function Register Description

Most of the Special Function Register details will be described in the relevant functional section; however several registers require a separate description in this section.

### Indirect Addressing Registers – IAR0, IAR1

The Indirect Addressing Registers, IAR0 and IAR1, although having their locations in normal RAM register space, do not actually physically exist as normal registers. The method of indirect addressing for RAM data manipulation uses these Indirect Addressing Registers and Memory Pointers, in contrast to direct memory addressing, where the actual memory address is specified. Actions on the IAR0 and IAR1 registers will result in no actual read or write operation to these registers but rather to the memory location specified by their corresponding Memory Pointers, MP0 or MP1. Acting as a pair, IAR0 and MP0 can together access data from Bank 0 while the IAR1 and MP1 register pair can access data from any bank. As the Indirect Addressing Registers are not physically implemented, reading the Indirect Addressing Registers indirectly will return a result of “00H” and writing to the registers indirectly will result in no operation.

### Memory Pointers – MP0, MP1

Two Memory Pointers, known as MP0 and MP1 are provided. These Memory Pointers are physically implemented in the Data Memory and can be manipulated in the same way as normal registers providing a convenient way with which to address and track data. When any operation to the relevant Indirect Addressing Registers is carried out, the actual address that the microcontroller is directed to is the address specified by the related Memory Pointer. MP0, together with Indirect Addressing Register, IAR0, are used to access data from Bank 0, while MP1 and IAR1 are used to access data from all banks according to BP register. Direct Addressing can only be used with Bank 0, all other Banks must be addressed indirectly using MP1 and IAR1.

The following example shows how to clear a section of four Data Memory locations already defined as locations adres1 to adres4.

### Indirect Addressing Program Example

```
data .section 'data'
adres1 db ?
adres2 db ?
adres3 db ?
adres4 db ?
block db ?
code .section at 0 'code'
org 00h
start:
    mov a, 04h           ; setup size of block
    mov block, a
    mov a, offset adres1 ; Accumulator loaded with first RAM address
    mov mp0, a          ; setup memory pointer with first RAM address
loop:
    clr IAR0            ; clear the data at address defined by MP0
    inc mp0             ; increment memory pointer
    sdz block           ; check if last memory location has been cleared
    jmp loop
continue:
```

The important point to note here is that in the examples shown above, no reference is made to specific Data Memory addresses.

### Bank Pointer – BP

For this device, the Data Memory is divided into two banks, Bank0 and Bank1. Selecting the required Data Memory area is achieved using the Bank Pointer. Bit 0 of the Bank Pointer is used to select Data Memory Bank 0~1.

The Data Memory is initialised to Bank 0 after a reset, except for a WDT time-out reset in the SLEEP or IDLE Mode, in which case, the Data Memory bank remains unaffected. It should be noted that the Special Function Data Memory is not affected by the bank selection, which means that the Special Function Registers can be accessed from within any bank. Directly addressing the Data Memory will always result in Bank 0 being accessed irrespective of the value of the Bank Pointer. Accessing data from banks other than Bank 0 must be implemented using Indirect Addressing.

#### • BP Register

Bit	7	6	5	4	3	2	1	0
Name	—	—	—	—	—	—	—	DMBP0
R/W	—	—	—	—	—	—	—	R/W
POR	—	—	—	—	—	—	—	0

Bit 7~1 Unimplemented, read as “0”

Bit 0 **DMBP0**: Select Data Memory Banks  
 0: Bank 0  
 1: Bank 1

### Accumulator – ACC

The Accumulator is central to the operation of any microcontroller and is closely related with operations carried out by the ALU. The Accumulator is the place where all intermediate results from the ALU are stored. Without the Accumulator it would be necessary to write the result of each calculation or logical operation such as addition, subtraction, shift, etc., to the Data Memory resulting in higher programming and timing overheads. Data transfer operations usually involve the temporary storage function of the Accumulator; for example, when transferring data between one user-defined register and another, it is necessary to do this by passing the data through the Accumulator as no direct transfer between two registers is permitted.

### Program Counter Low Register – PCL

To provide additional program control functions, the low byte of the Program Counter is made accessible to programmers by locating it within the Special Purpose area of the Data Memory. By manipulating this register, direct jumps to other program locations are easily implemented. Loading a value directly into this PCL register will cause a jump to the specified Program Memory location, however, as the register is only 8-bit wide, only jumps within the current Program Memory page are permitted. When such operations are used, note that a dummy cycle will be inserted.

### Look-up Table Registers – TBLP, TBHP, TBLH

These three special function registers are used to control operation of the look-up table which is stored in the Program Memory. TBLP and TBHP are the table pointers and indicate the location where the table data is located. Their value must be setup before any table read commands are executed. Their value can be changed, for example using the “INC” or “DEC” instructions, allowing for easy table data pointing and reading. TBLH is the location where the high order byte of the table data is stored after a table read data instruction has been executed. Note that the lower order table data byte is transferred to a user defined location.

### Status Register – STATUS

This 8-bit register contains the zero flag (Z), carry flag (C), auxiliary carry flag (AC), overflow flag (OV), power down flag (PDF), and watchdog time-out flag (TO). These arithmetic/logical operation and system management flags are used to record the status and operation of the microcontroller.

With the exception of the TO and PDF flags, bits in the status register can be altered by instructions like most other registers. Any data written into the status register will not change the TO or PDF flag. In addition, operations related to the status register may give different results due to the different instruction operations. The TO flag can be affected only by a system power-up, a WDT time-out or by executing the “CLR WDT” or “HALT” instruction. The PDF flag is affected only by executing the “HALT” or “CLR WDT” instruction or during a system power-up.

The Z, OV, AC, and C flags generally reflect the status of the latest operations.

- **C** is set if an operation results in a carry during an addition operation or if a borrow does not take place during a subtraction operation; otherwise C is cleared. C is also affected by a rotate through carry instruction.
- **AC** is set if an operation results in a carry out of the low nibbles in addition, or no borrow from the high nibble into the low nibble in subtraction; otherwise AC is cleared.
- **Z** is set if the result of an arithmetic or logical operation is zero; otherwise Z is cleared.
- **OV** is set if an operation results in a carry into the highest-order bit but not a carry out of the highest-order bit, or vice versa; otherwise OV is cleared.
- **PDF** is cleared by a system power-up or executing the “CLR WDT” instruction. PDF is set by executing the “HALT” instruction.
- **TO** is cleared by a system power-up or executing the “CLR WDT” or “HALT” instruction. TO is set by a WDT time-out.

In addition, on entering an interrupt sequence or executing a subroutine call, the status register will not be pushed onto the stack automatically. If the contents of the status registers are important and if the subroutine can corrupt the status register, precautions must be taken to correctly save it.

#### • STATUS Register

Bit	7	6	5	4	3	2	1	0
Name	—	—	TO	PDF	OV	Z	AC	C
R/W	—	—	R	R	R/W	R/W	R/W	R/W
POR	—	—	0	0	x	x	x	x

“x”: unknown

- Bit 7~6      Unimplemented, read as “0”
- Bit 5      **TO**: Watchdog Time-out flag  
0: After power up or executing the “CLR WDT” or “HALT” instruction  
1: A watchdog time-out occurred.
- Bit 4      **PDF**: Power down flag  
0: After power up or executing the “CLR WDT” instruction  
1: By executing the “HALT” instruction
- Bit 3      **OV**: Overflow flag  
0: No overflow  
1: An operation results in a carry into the highest-order bit but not a carry out of the highest-order bit or vice versa.
- Bit 2      **Z**: Zero flag  
0: The result of an arithmetic or logical operation is not zero  
1: The result of an arithmetic or logical operation is zero

- Bit 1      **AC:** Auxiliary flag  
             0: No auxiliary carry  
             1: An operation results in a carry out of the low nibbles in addition, or no borrow from the high nibble into the low nibble in subtraction
- Bit 0      **C:** Carry flag  
             0: No carry-out  
             1: An operation results in a carry during an addition operation or if a borrow does not take place during a subtraction operation
- The “C” flag is also affected by a rotate through carry instruction.

## Emulated EEPROM Data Memory

The device contains an Emulated EEPROM Data Memory, which is by its nature a non-volatile form of re-programmable memory, with data retention even when its power supply is removed. By incorporating this kind of data memory, a whole new host of application possibilities are made available to the designer. The availability of the Emulated EEPROM storage allows information such as product identification numbers, calibration values, specific user data, system setup data or other product information to be stored directly within the product microcontroller.

### Emulated EEPROM Data Memory Structure

The Emulated EEPROM Data Memory capacity is 32×15 bits for the device. The Emulated EEPROM Erase operation is carried out in a page format while the Write operation is carried out in 4-word format and the Read operation in a word format. The page size is assigned with a capacity of 16 words. Note that the Erase operation should be executed before the Write operation is executed.

Operations	Format
Erase	1 page/time
Write	4 words/time
Read	1 word/time

Note: Page size = 16 words

#### Emulated EEPROM Erase/Write/Read Format

Erase Page	EAR4	EAR[3:0]
0	0	xxxx
1	1	xxxx

“x”: don't care

#### Erase Page Number and Selection

Write Unit	EAR[4:2]	EAR[1:0]
0	000	xx
1	001	xx
2	010	xx
3	011	xx
4	100	xx
5	101	xx
6	110	xx
7	111	xx

“x”: don't care

#### Write Unit Number and Selection

## Emulated EEPROM Registers

Several registers control the overall operation of the Emulated EEPROM Data Memory. These are the address register, EAR, the data registers, ED0L/ED0H ~ ED3L/ED3H, and a single control register, ECR.

Register Name	Bit							
	7	6	5	4	3	2	1	0
EAR	—	—	—	EAR4	EAR3	EAR2	EAR1	EAR0
ED0L	D7	D6	D5	D4	D3	D2	D1	D0
ED0H	—	D14	D13	D12	D11	D10	D9	D8
ED1L	D7	D6	D5	D4	D3	D2	D1	D0
ED1H	—	D14	D13	D12	D11	D10	D9	D8
ED2L	D7	D6	D5	D4	D3	D2	D1	D0
ED2H	—	D14	D13	D12	D11	D10	D9	D8
ED3L	D7	D6	D5	D4	D3	D2	D1	D0
ED3H	—	D14	D13	D12	D11	D10	D9	D8
ECR	EWRTS1	EWRTS0	EEREN	EER	EWREN	EWR	ERDEN	ERD

**Emulated EEPROM Register List**

### • EAR Register

Bit	7	6	5	4	3	2	1	0
Name	—	—	—	EAR4	EAR3	EAR2	EAR1	EAR0
R/W	—	—	—	R/W	R/W	R/W	R/W	R/W
POR	—	—	—	0	0	0	0	0

Bit 7~5 Unimplemented, read as “0”

Bit 4~0 **EAR4~EAR0**: Emulated EEPROM address bit 4 ~ bit 0

### • ED0L Register

Bit	7	6	5	4	3	2	1	0
Name	D7	D6	D5	D4	D3	D2	D1	D0
R/W	R/W	R/W	R/W	R/W	R/W	R/W	R/W	R/W
POR	0	0	0	0	0	0	0	0

Bit 7~0 **D7~D0**: The first Emulated EEPROM data bit 7 ~ bit 0

### • ED0H Register

Bit	7	6	5	4	3	2	1	0
Name	—	D14	D13	D12	D11	D10	D9	D8
R/W	—	R/W	R/W	R/W	R/W	R/W	R/W	R/W
POR	—	0	0	0	0	0	0	0

Bit 7 Unimplemented, read as “0”

Bit 6~0 **D14~D8**: The first Emulated EEPROM data bit 14 ~ bit 8

### • ED1L Register

Bit	7	6	5	4	3	2	1	0
Name	D7	D6	D5	D4	D3	D2	D1	D0
R/W	R/W	R/W	R/W	R/W	R/W	R/W	R/W	R/W
POR	0	0	0	0	0	0	0	0

Bit 7~0 **D7~D0**: The second Emulated EEPROM data bit 7 ~ bit 0

• ED1H Register

Bit	7	6	5	4	3	2	1	0
Name	—	D14	D13	D12	D11	D10	D9	D8
R/W	—	R/W	R/W	R/W	R/W	R/W	R/W	R/W
POR	—	0	0	0	0	0	0	0

Bit 7 Unimplemented, read as “0”

Bit 6~0 **D14~D8**: The second Emulated EEPROM data bit 14 ~ bit 8

• ED2L Register5

Bit	7	6	5	4	3	2	1	0
Name	D7	D6	D5	D4	D3	D2	D1	D0
R/W	R/W	R/W	R/W	R/W	R/W	R/W	R/W	R/W
POR	0	0	0	0	0	0	0	0

Bit 7~0 **D7~D0**: The third Emulated EEPROM data bit 7 ~ bit 0

• ED2H Register

Bit	7	6	5	4	3	2	1	0
Name	—	D14	D13	D12	D11	D10	D9	D8
R/W	—	R/W	R/W	R/W	R/W	R/W	R/W	R/W
POR	—	0	0	0	0	0	0	0

Bit 7 Unimplemented, read as “0”

Bit 6~0 **D14~D8**: The third Emulated EEPROM data bit 14 ~ bit 8

• ED3L Register

Bit	7	6	5	4	3	2	1	0
Name	D7	D6	D5	D4	D3	D2	D1	D0
R/W	R/W	R/W	R/W	R/W	R/W	R/W	R/W	R/W
POR	0	0	0	0	0	0	0	0

Bit 7~0 **D7~D0**: The fourth Emulated EEPROM data bit 7 ~ bit 0

• ED3H Register

Bit	7	6	5	4	3	2	1	0
Name	—	D14	D13	D12	D11	D10	D9	D8
R/W	—	R/W	R/W	R/W	R/W	R/W	R/W	R/W
POR	—	0	0	0	0	0	0	0

Bit 7 Unimplemented, read as “0”

Bit 6~0 **D14~D8**: The fourth Emulated EEPROM data bit 14 ~ bit 8

• ECR Register

Bit	7	6	5	4	3	2	1	0
Name	EWRTS1	EWRTS0	EEREN	EER	EWREN	EWR	ERDEN	ERD
R/W	R/W	R/W	R/W	R/W	R/W	R/W	R/W	R/W
POR	0	0	0	0	0	0	0	0

Bit 7~6 **EWRTS1~EWRTS0**: Emulated EEPROM Erase/Write time selection  
 00: 2ms  
 01: 4ms  
 10: 8ms  
 11: 16ms

Bit 5	<b>EEREN</b> : Emulated EEPROM Erase enable 0: Disable 1: Enable  This bit is used to enable the Emulated EEPROM erase function and must be set high before erase operations are carried out. This bit will be automatically reset to zero by the hardware after the erase cycle has finished. Clearing this bit to zero will inhibit the Emulated EEPROM erase operations.
Bit 4	<b>EER</b> : Emulated EEPROM Erase control 0: Erase cycle has finished 1: Activate an erase cycle  When this bit is set high by the application program, an erase cycle will be activated. This bit will be automatically reset to zero by the hardware after the erase cycle has finished. Setting this bit high will have no effect if the EEREN has not first been set high.
Bit 3	<b>EWREN</b> : Emulated EEPROM Write enable 0: Disable 1: Enable  This bit is used to enable the Emulated EEPROM write function and must be set high before write operations are carried out. This bit will be automatically reset to zero by the hardware after the write cycle has finished. Clearing this bit to zero will inhibit the Emulated EEPROM write operations.
Bit 2	<b>EWR</b> : Emulated EEPROM Write control 0: Write cycle has finished 1: Activate a write cycle  When this bit is set high by the application program, a write cycle will be activated. This bit will be automatically reset to zero by the hardware after the write cycle has finished. Setting this bit high will have no effect if the EWREN has not first been set high.
Bit 1	<b>ERDEN</b> : Emulated EEPROM Read enable 0: Disable 1: Enable  This bit is used to enable the Emulated EEPROM read function and must be set high before read operations are carried out. Clearing this bit to zero will inhibit the Emulated EEPROM read operations.
Bit 0	<b>ERD</b> : Emulated EEPROM Read control 0: Read cycle has finished 1: Activate a read cycle  When this bit is set high by the application program, a read cycle will be activated. This bit will be automatically reset to zero by the hardware after the read cycle has finished. Setting this bit high will have no effect if the ERDEN has not first been set high.

- Note: 1. The EEREN, EER, EWREN, EWR, ERDEN and ERD cannot be set to “1” at the same time in one instruction.
2. Note that the CPU will be stopped when a read, write or erase operation is successfully activated.
  3. Ensure that the  $f_{SYS}$  clock frequency is equal to or greater than 2MHz and the  $f_{SUB}$  clock is stable before executing the erase or write operation.
  4. Ensure that the read, write or erase operation is totally complete before executing other operations.

## **Erasing the Emulated EEPROM**

For Emulated EEPROM erase operation the desired erase page address should first be placed in the EAR register. The number of the erase operation is 16 words per page each time, therefore, the available page erase address is only specified by the EAR4 bit in the EAR register and the content of EAR3~EAR0 in the EAR register is not used to specify the page address. To erase the Emulated EEPROM page, the EEREN bit in the ECR register must first be set high to enable the erase function. After this the EER bit in the ECR register must be immediately set high to initiate an erase cycle. These two instructions must be executed in two consecutive instruction cycles to activate an erase operation successfully. The global interrupt bit EMI should also first be cleared before implementing any erase operations, and then set high again after a valid erase activation procedure has completed. Note that the CPU will be stopped when an erase operation is successfully activated. When the erase cycle terminates, the CPU will resume executing the application program. And the EER bit will be automatically cleared to zero by the microcontroller, informing the user that the data has been erased. The Emulated EEPROM erased page content will all be zero after an erase operation.

## **Writing Data to the Emulated EEPROM**

For Emulated EEPROM write operation the desired write unit address should first be placed in the EAR register and the data placed in the ED0L/ED0H~ED3L/ED3H registers. The number of the write operation is 4 words each time, therefore, the available write unit address is only specified by the EAR4~EAR2 bits in the EAR register and the content of EAR1~EAR0 in the EAR register is not used to specify the unit address. To write data to the Emulated EEPROM, the EWREN bit in the ECR register must first be set high to enable the write function. After this the EWR bit in the ECR register must be immediately set high to initiate a write cycle. These two instructions must be executed in two consecutive instruction cycles to activate a write operation successfully. The global interrupt bit EMI should also first be cleared before implementing any write operations, and then set high again after a valid write activation procedure has completed. Note that the CPU will be stopped when a write operation is successfully activated. When the write cycle terminates, the CPU will resume executing the application program. And the EWR bit will be automatically cleared to zero by the microcontroller, informing the user that the data has been written to the Emulated EEPROM.

## **Reading Data from the Emulated EEPROM**

For Emulated EEPROM read operation the desired read address should first be placed in the EAR register. To read data from the Emulated EEPROM, the ERDEN bit in the ECR register must first be set high to enable the read function. After this a read cycle will be initiated if the ERD bit in the ECR register is now set high. Note that the CPU will be stopped when the read operation is successfully activated. When the read cycle terminates, the CPU will resume executing the application program. And the ERD bit will be automatically cleared to zero by the microcontroller, informing the user that the data has been read from the Emulated EEPROM. Then the data can be read from the ED0H/ED0L data register pair by application program. The data will remain in the data register pair until another read, write or erase operation is executed.

## **Programming Considerations**

Care must be taken that data is not inadvertently written to the Emulated EEPROM. Protection can be enhanced by ensuring that the Write Enable bit is normally cleared to zero when not writing. Although certainly not necessary, consideration might be given in the application program to the checking of the validity of new write data by a simple read back process. When writing or erasing data the EWR or EER bit must be set high immediately after the EWREN or EEREN bit has been

set high, to ensure the write or erase cycle executes correctly. The global interrupt bit EMI should also be cleared before a write or erase cycle is executed and then set again after a valid write or erase activation procedure has completed. Note that the device should not enter the IDLE or SLEEP mode until Emulated EEPROM read, write or erase operation is totally complete. Otherwise, Emulated EEPROM read, write or erase operation will fail.

### Programming Examples

#### Erase a Data Page of the Emulated EEPROM – polling method

```

MOV A, EEPROM_ADRES      ; user-defined page
MOV EAR, A
MOV A, 00H                ; Erase time=2ms (40H for 4ms, 80H for 8ms, C0H for 16ms)
MOV ECR, A
CLR EMI
SET EEREN                 ; set EEREN bit, enable erase operation
SET EER                   ; start Erase Cycle - set EER bit - executed immediately
                           ; after setting EEREN bit

SET EMI
BACK:
SZ EER                    ; check for erase cycle end
JMP BACK
:

```

#### Writing Data to the Emulated EEPROM – polling method

```

MOV A, EEPROM_ADRES      ; user-defined address
MOV EAR, A
MOV A, EEPROM_DATA0_L    ; user-defined data
MOV ED0L, A
MOV A, EEPROM_DATA0_H
MOV ED0H, A
MOV A, EEPROM_DATA1_L
MOV ED1L, A
MOV A, EEPROM_DATA1_H
MOV ED1H, A
MOV A, EEPROM_DATA2_L
MOV ED2L, A
MOV A, EEPROM_DATA2_H
MOV ED2H, A
MOV A, EEPROM_DATA3_L
MOV ED3L, A
MOV A, EEPROM_DATA3_H
MOV ED3H, A
MOV A, 00H                ; Write time=2ms (40H for 4ms, 80H for 8ms, C0H for 16ms)
MOV ECR, A
CLR EMI
SET EWREN                 ; set EWREN bit, enable write operation
SET EWR                   ; start Write Cycle - set EWR bit - executed immediately
                           ; after set EWREN bit

SET EMI
BACK:
SZ EWR                    ; check for write cycle end
JMP BACK
:

```

**Reading Data from the Emulated EEPROM – polling method**

```

MOV A, EEPROM_ADRES      ; user-defined address
MOV EAR, A
SET ERDEN                ; set ERDEN bit, enable read operation
SET ERD                  ; start Read Cycle - set ERD bit
BACK:
SZ ERD                   ; check for read cycle end
JMP BACK
CLR ECR                  ; disable Emulated EEPROM read if no more read operations
                          ; are required
MOV A, ED0L              ; move read data which is placed in the ED0L/ED0H
                          ; to user-defined registers

MOV READ_DATA_L, A
MOV A, ED0H
MOV READ_DATA_H, A

```

Note: For each read operation, the address register should be re-specified followed by setting the ERD bit high to activate a read cycle even if the target address is consecutive.

**Oscillators**

Various oscillator options offer the user a wide range of functions according to their various application requirements. The flexible features of the oscillator functions ensure that the best optimisation can be achieved in terms of speed and power saving. Oscillator selections and operation are selected through the application program by using relevant control registers.

**Oscillator Overview**

In addition to being the source of the main system clock the oscillators also provide clock sources for the Watchdog Timer and Time Base Interrupts. Two fully integrated internal oscillators, requiring no external components, are provided to form a wide range of both fast and slow system oscillators. The higher frequency oscillators provide higher performance but carry with it the disadvantage of higher power requirements, while the opposite is of course true for the lower frequency oscillators. With the capability of dynamically switching between fast and slow system clock, the device has the flexibility to optimize the performance/power ratio, a feature especially important in power sensitive portable applications.

Type	Name	Frequency
Internal High Speed RC	HIRC	8MHz
Internal Low Speed RC	LIRC	32kHz

**Oscillator Types**

**System Clock Configurations**

There are two methods of generating the system clock, one high speed oscillator and one low speed oscillator. The high speed oscillator is the internal 8MHz RC oscillator, HIRC. The low speed oscillator is the internal 32kHz RC oscillator, LIRC. Selecting whether the low or high speed oscillator is used as the system oscillator is implemented using the CKS2~CKS0 bits in the SCC register and as the system clock can be dynamically selected.

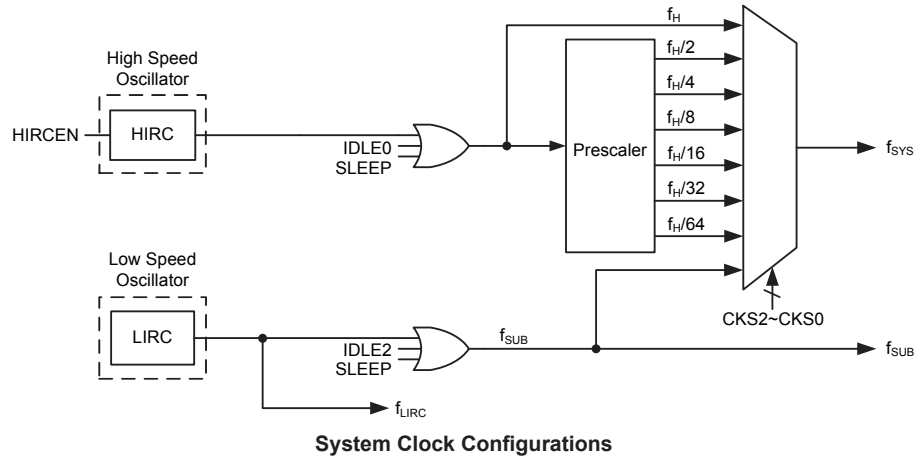

### Internal High Speed RC Oscillator – HIRC

The internal high speed RC oscillator is a fully integrated system oscillator requiring no external components. The internal RC oscillator has a fixed frequency of 8MHz. Device trimming during the manufacturing process and the inclusion of internal frequency compensation circuits are used to ensure that the influence of the power supply voltage, temperature and process variations on the oscillation frequency are minimised.

### Internal 32kHz Oscillator – LIRC

The Internal 32kHz System Oscillator is the low frequency oscillator. It is a fully integrated RC oscillator with a typical frequency of 32kHz, requiring no external components for its implementation.

## Operating Modes and System Clocks

Present day applications require that their microcontrollers have high performance but often still demand that they consume as little power as possible, conflicting requirements that are especially true in battery powered portable applications. The fast clocks required for high performance will by their nature increase current consumption and of course vice versa, lower speed clocks reduce current consumption. As Holtek has provided the device with both high and low speed clock sources and the means to switch between them dynamically, the user can optimise the operation of their microcontroller to achieve the best performance/power ratio.

### System Clocks

The device has many different clock sources for both the CPU and peripheral function operation. By providing the user with a wide range of clock options using register programming, a clock system can be configured to obtain maximum application performance.

The main system clock, can come from either a high frequency,  $f_{H}$ , or low frequency,  $f_{SUB}$ , source, and is selected using the CKS2~CKS0 bits in the SCC register. The high speed system clock is sourced from the HIRC oscillator. The low speed system clock source is sourced from the LIRC oscillator. The other choice, which is a divided version of the high speed system oscillator has a range of  $f_{H}/2 \sim f_{H}/64$ .

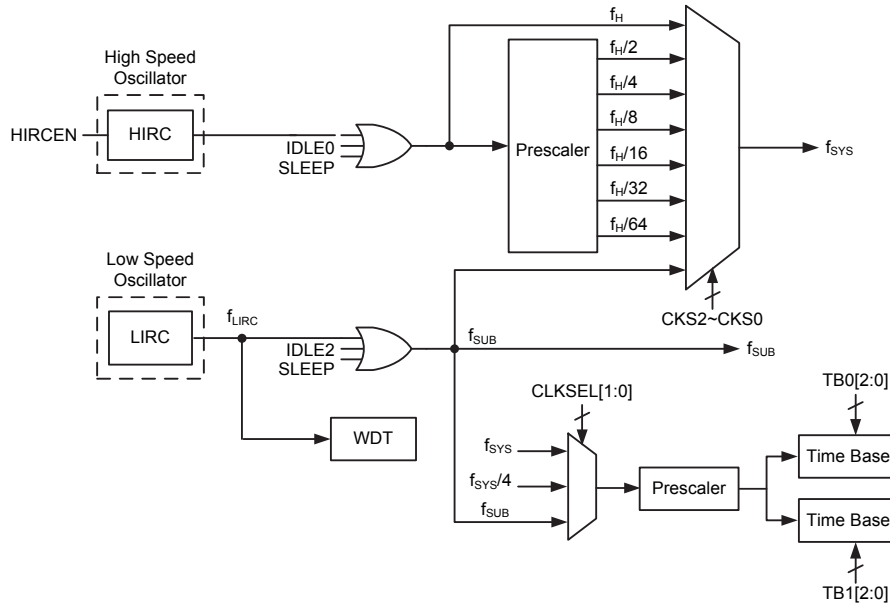

**Device Clock Configurations**

Note: When the system clock source  $f_{SYS}$  is switched to  $f_{SUB}$  from  $f_H$ , the high speed oscillator will stop to conserve the power or continue to oscillate to provide the clock source,  $f_H \sim f_H/64$ , for peripheral circuit to use, which is determined by configuring the corresponding high speed oscillator enable control bit.

**System Operation Modes**

There are six different modes of operation for the microcontroller, each one with its own special characteristics and which can be chosen according to the specific performance and power requirements of the application. There are two modes allowing normal operation of the microcontroller, the FAST Mode and SLOW Mode. The remaining four modes, the SLEEP, IDLE0, IDLE1 and IDLE2 Mode are used when the microcontroller CPU is switched off to conserve power.

Operation Mode	CPU	Register Setting			$f_{SYS}$	$f_H$	$f_{SUB}$	$f_{LIRC}$
		FHIDEN	FSIDEN	CKS2~CKS0				
FAST	On	x	x	000~110	$f_H \sim f_H/64$	On	On	On
SLOW	On	x	x	111	$f_{SUB}$	On/Off <sup>(1)</sup>	On	On
IDLE0	Off	0	1	000~110	Off	Off	On	On
				111	On			
IDLE1	Off	1	1	xxx	On	On	On	On
IDLE2	Off	1	0	000~110	On	On	Off	On
				111	Off			
SLEEP	Off	0	0	xxx	Off	Off	Off	On/Off <sup>(2)</sup>

"x": Don't care

Note: 1. The  $f_H$  clock will be switched on or off by configuring the corresponding oscillator enable bit in the SLOW mode.

2. The  $f_{LIRC}$  clock can be switched on or off which is controlled by the WDT function being enabled or disabled in the SLEEP mode.

### FAST Mode

This is one of the main operating modes where the microcontroller has all of its functions operational and where the system clock is provided by the high speed oscillator. This mode operates allowing the microcontroller to operate normally with a clock source will come from the high speed oscillator HIRC. The high speed oscillator will however first be divided by a ratio ranging from 1 to 64, the actual ratio being selected by the CKS2~CKS0 bits in the SCC register. Although a high speed oscillator is used, running the microcontroller at a divided clock ratio reduces the operating current.

### SLOW Mode

This is also a mode where the microcontroller operates normally although now with a slower speed clock source. The clock source used will be from  $f_{SUB}$ . The  $f_{SUB}$  clock is derived from the LIRC oscillator. Running the microcontroller in this mode allows it to run with much lower operating currents

### SLEEP Mode

The SLEEP Mode is entered when a HALT instruction is executed and when the FHIDEN and FSIDEN bits are low. In the SLEEP mode the CPU will be stopped. The  $f_{SUB}$  clock provided to the peripheral function will also be stopped, too. However the  $f_{LIRC}$  clock can continue to operate if the WDT function is enabled.

### IDLE0 Mode

The IDLE0 Mode is entered when a HALT instruction is executed and when the FHIDEN bit in the SCC register is low and the FSIDEN bit in the SCC register is high. In the IDLE0 Mode the CPU will be switched off but the low speed oscillator will be turned on to drive some peripheral functions.

### IDLE1 Mode

The IDLE1 Mode is entered when a HALT instruction is executed and when the FHIDEN bit in the SCC register is high and the FSIDEN bit in the SCC register is high. In the IDLE1 Mode the CPU will be switched off but both the high and low speed oscillators will be turned on to provide a clock source to keep some peripheral functions operational.

### IDLE2 Mode

The IDLE2 Mode is entered when a HALT instruction is executed and when the FHIDEN bit in the SCC register is high and the FSIDEN bit in the SCC register is low. In the IDLE2 Mode the CPU will be switched off but the high speed oscillator will be turned on to provide a clock source to keep some peripheral functions operational.

## Control Registers

The registers, SCC and HIRCC, are used to control the system clock and the corresponding oscillator configurations.

Register Name	Bit							
	7	6	5	4	3	2	1	0
SCC	CKS2	CKS1	CKS0	—	—	—	FHIDEN	FSIDEN
HIRCC	—	—	—	—	—	—	HIRCF	HIRCEN

**System Operating Mode Control Register List**

• **SCC Register**

Bit	7	6	5	4	3	2	1	0
Name	CKS2	CKS1	CKS0	—	—	—	FHIDEN	FSIDEN
R/W	R/W	R/W	R/W	—	—	—	R/W	R/W
POR	0	0	0	—	—	—	0	0

Bit 7~5     **CKS2~CKS0**: System clock selection

000:  $f_H$   
 001:  $f_H/2$   
 010:  $f_H/4$   
 011:  $f_H/8$   
 100:  $f_H/16$   
 101:  $f_H/32$   
 110:  $f_H/64$   
 111:  $f_{SUB}$

These three bits are used to select which clock is used as the system clock source. In addition to the system clock source directly derived from  $f_H$  or  $f_{SUB}$ , a divided version of the high speed system oscillator can also be chosen as the system clock source.

Bit 4~2     Unimplemented, read as “0”

Bit 1       **FHIDEN**: High Frequency oscillator control when CPU is switched off

0: Disable  
 1: Enable

This bit is used to control whether the high speed oscillator is activated or stopped when the CPU is switched off by executing an “HALT” instruction.

Bit 0       **FSIDEN**: Low Frequency oscillator control when CPU is switched off

0: Disable  
 1: Enable

This bit is used to control whether the low speed oscillator is activated or stopped when the CPU is switched off by executing an “HALT” instruction.

• **HIRCC Register**

Bit	7	6	5	4	3	2	1	0
Name	—	—	—	—	—	—	HIRCF	HIRCEN
R/W	—	—	—	—	—	—	R	R/W
POR	—	—	—	—	—	—	0	1

Bit 7~2     Unimplemented, read as “0”

Bit 1       **HIRCF**: HIRC oscillator stable flag

0: HIRC unstable  
 1: HIRC stable

This bit is used to indicate whether the HIRC oscillator is stable or not. When the HIRCEN bit is set to 1 to enable the HIRC oscillator, the HIRCF bit will first be cleared to 0 and then set to 1 after the HIRC oscillator is stable.

Bit 0       **HIRCEN**: HIRC oscillator enable control

0: Disable  
 1: Enable

### Operating Mode Switching

The device can switch between operating modes dynamically allowing the user to select the best performance/power ratio for the present task in hand. In this way microcontroller operations that do not require high performance can be executed using slower clocks thus requiring less operating current and prolonging battery life in portable applications.

In simple terms, Mode Switching between the FAST Mode and SLOW Mode is executed using the CKS2~CKS0 bits in the SCC register while Mode Switching from the FAST/SLOW Modes to the SLEEP/IDLE Modes is executed via the HALT instruction. When a HALT instruction is executed, whether the device enters the IDLE Mode or the SLEEP Mode is determined by the condition of the FHIDEN and FSIDEN bits in the SCC register.

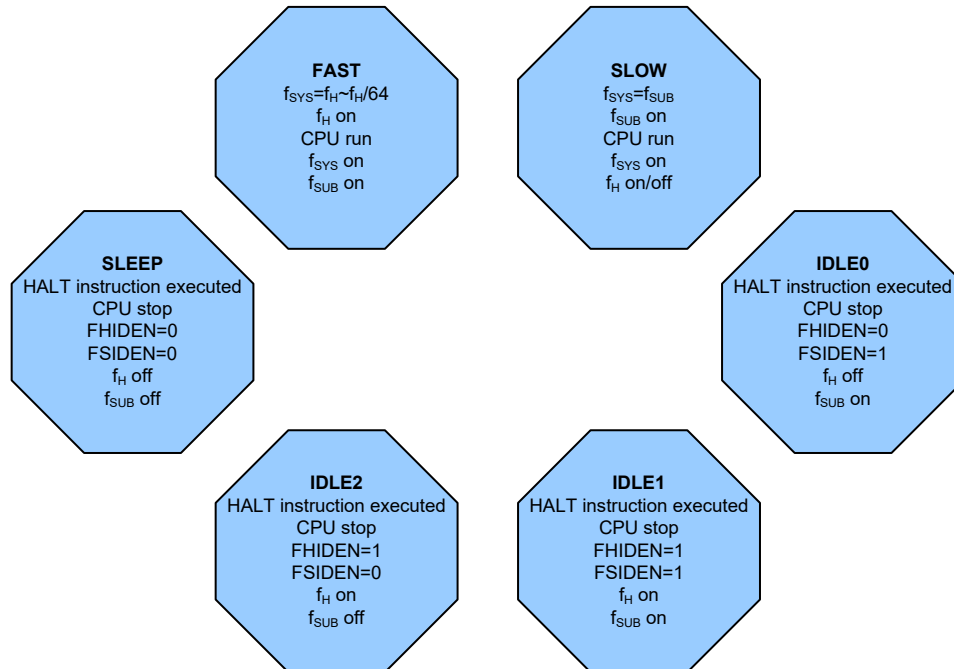

### FAST Mode to SLOW Mode Switching

When running in the FAST Mode, which uses the high speed system oscillator, and therefore consumes more power, the system clock can switch to run in the SLOW Mode by setting the CKS2~CKS0 bits to “111” in the SCC register. This will then use the low speed system oscillator which will consume less power. Users may decide to do this for certain operations which do not require high performance and can subsequently reduce power consumption.

The SLOW Mode is sourced from the LIRC oscillator and therefore requires this oscillator to be stable before full mode switching occurs.

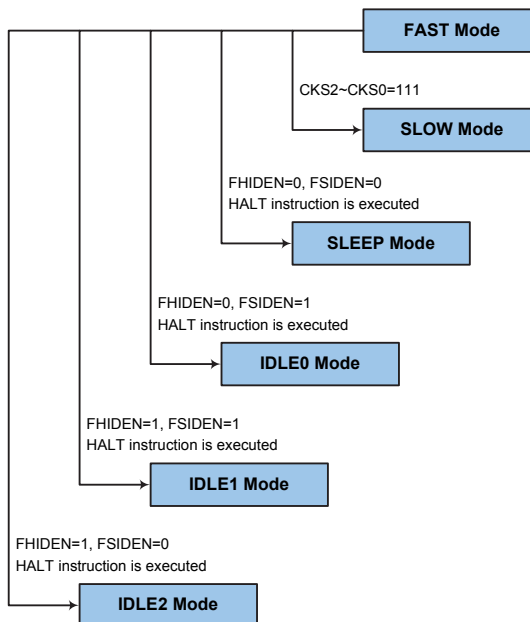

### SLOW Mode to FAST Mode Switching

In SLOW mode the system clock is derived from  $f_{SUB}$ . When system clock is switched back to the FAST mode from  $f_{SUB}$ , the CKS2~CKS0 bits should be set to “000”~“110” and then the system clock will respectively be switched to  $f_H \sim f_H/64$ .

However, if  $f_H$  is not used in SLOW mode and thus switched off, it will take some time to re-oscillate and stabilise when switching to the FAST mode from the SLOW Mode. This is monitored using the HIRCF bit in the HIRCC register. The time duration required for the high speed system oscillator stabilization is specified in the System Start Up Time Characteristics.

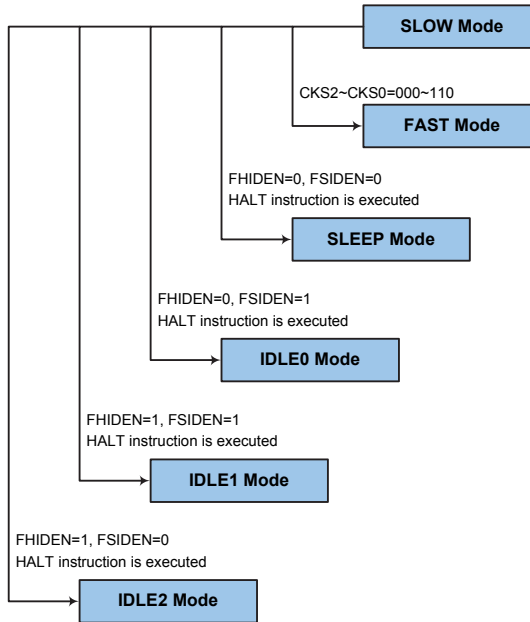

### Entering the SLEEP Mode

There is only one way for the device to enter the SLEEP Mode and that is to execute the “HALT” instruction in the application program with both the FHIDEN and FSIDEN bits in the SCC register equal to “0”. In this mode all the clocks and functions will be switched off except the WDT function. When this instruction is executed under the conditions described above, the following will occur:

- The system clock will be stopped and the application program will stop at the “HALT” instruction.
- The Data Memory contents and registers will maintain their present condition.
- The I/O ports will maintain their present conditions.
- In the status register, the Power Down flag, PDF, will be set and the Watchdog time-out flag, TO, will be cleared.
- The WDT will be cleared and resume counting if the WDT function is enabled. If the WDT function is disabled, the WDT will be cleared and then stopped.

### **Entering the IDLE0 Mode**

There is only one way for the device to enter the IDLE0 Mode and that is to execute the “HALT” instruction in the application program with the FHIDEN bit in the SCC register equal to “0” and the FSIDEN bit in the SCC register equal to “1”. When this instruction is executed under the conditions described above, the following will occur:

- The  $f_H$  clock will be stopped and the application program will stop at the “HALT” instruction, but the  $f_{SUB}$  clock will be on.
- The Data Memory contents and registers will maintain their present condition.
- The I/O ports will maintain their present conditions.
- In the status register, the Power Down flag, PDF, will be set and the Watchdog time-out flag, TO, will be cleared.
- The WDT will be cleared and resume counting if the WDT function is enabled. If the WDT function is disabled, the WDT will be cleared and then stopped.

### **Entering the IDLE1 Mode**

There is only one way for the device to enter the IDLE1 Mode and that is to execute the “HALT” instruction in the application program with both the FHIDEN and FSIDEN bits in the SCC register equal to “1”. When this instruction is executed under the conditions described above, the following will occur:

- The  $f_H$  and  $f_{SUB}$  clocks will be on but the application program will stop at the “HALT” instruction.
- The Data Memory contents and registers will maintain their present condition.
- The I/O ports will maintain their present conditions.
- In the status register, the Power Down flag, PDF, will be set and the Watchdog time-out flag, TO, will be cleared.
- The WDT will be cleared and resume counting if the WDT function is enabled. If the WDT function is disabled, the WDT will be cleared and then stopped.

### **Entering the IDLE2 Mode**

There is only one way for the device to enter the IDLE2 Mode and that is to execute the “HALT” instruction in the application program with the FHIDEN bit in the SCC register equal to “1” and the FSIDEN bit in the SCC register equal to “0”. When this instruction is executed under the conditions described above, the following will occur:

- The  $f_H$  clock will be on but the  $f_{SUB}$  clock will be off and the application program will stop at the “HALT” instruction.
- The Data Memory contents and registers will maintain their present condition.
- The I/O ports will maintain their present conditions.
- In the status register, the Power Down flag, PDF, will be set and the Watchdog time-out flag, TO, will be cleared.
- The WDT will be cleared and resume counting if the WDT function is enabled. If the WDT function is disabled, the WDT will be cleared and then stopped.

## Standby Current Considerations

As the main reason for entering the SLEEP or IDLE Mode is to keep the current consumption of the device to as low a value as possible, perhaps only in the order of several micro-amps except in the IDLE1 and IDLE2 Mode, there are other considerations which must also be taken into account by the circuit designer if the power consumption is to be minimised. Special attention must be made to the I/O pins on the device. All high-impedance input pins must be connected to either a fixed high or low level as any floating input pins could create internal oscillations and result in increased current consumption. This also applies to the device which has different package types, as there may be unbonded pins. These must either be setup as outputs or if setup as inputs must have pull-high resistors connected.

Care must also be taken with the loads, which are connected to I/O pins, which are setup as outputs. These should be placed in a condition in which minimum current is drawn or connected only to external circuits that do not draw current, such as other CMOS inputs. Also note that additional standby current will also be required if the LIRC oscillator has enabled.

In the IDLE1 and IDLE2 Mode the high speed oscillator is on, if the peripheral function clock source is derived from the high speed oscillator, the additional standby current will also be perhaps in the order of several hundred micro-amps.

## Wake-up

To minimise power consumption the device can enter the SLEEP or any IDLE Mode, where the CPU will be switched off. However, when the device is woken up again, it will take a considerable time for the original system oscillator to restart, stabilise and allow normal operation to resume.

After the system enters the SLEEP or IDLE Mode, it can be woken up from one of various sources listed as follows:

- An external falling edge on Port A
- A system interrupt
- A WDT overflow

When the device executes the “HALT” instruction, the PDF flag will be set to 1. The PDF flag will be cleared to 0 if the device experiences a system power-up or executes the clear Watchdog Timer instruction. If the system is woken up by a WDT overflow, a Watchdog Timer reset will be initiated and the TO flag will be set to 1. The TO flag is set if a WDT time-out occurs and causes a wake-up that only resets the Program Counter and Stack Pointer, other flags remain in their original status.

Each pin on Port A can be setup using the PAWU register to permit a negative transition on the pin to wake-up the system. When a pin wake-up occurs, the program will resume execution at the instruction following the “HALT” instruction. If the system is woken up by an interrupt, then two possible situations may occur. The first is where the related interrupt is disabled or the interrupt is enabled but the stack is full, in which case the program will resume execution at the instruction following the “HALT” instruction. In this situation, the interrupt which woke-up the device will not be immediately serviced, but will rather be serviced later when the related interrupt is finally enabled or when a stack level becomes free. The other situation is where the related interrupt is enabled and the stack is not full, in which case the regular interrupt response takes place. If an interrupt request flag is set high before entering the SLEEP or IDLE Mode, the wake-up function of the related interrupt will be disabled.

## Watchdog Timer

The Watchdog Timer is provided to prevent program malfunctions or sequences from jumping to unknown locations, due to certain uncontrollable external events such as electrical noise.

### Watchdog Timer Clock Source

The Watchdog Timer clock source is provided by the internal  $f_{LIRC}$  clock which is sourced from the LIRC oscillator. The LIRC internal oscillator has an approximate frequency of 32kHz and this specified internal clock period can vary with  $V_{DD}$ , temperature and process variations. The Watchdog Timer source clock is then subdivided by a ratio of  $2^8$  to  $2^{15}$  to give longer timeouts, the actual value being chosen using the WS2~WS0 bits in the WDTC register.

### Watchdog Timer Control Register

A single register, WDTC, controls the required time-out period as well as the enable/disable and reset MCU operation.

#### • WDTC Register

Bit	7	6	5	4	3	2	1	0
Name	WE4	WE3	WE2	WE1	WE0	WS2	WS1	WS0
R/W	R/W	R/W	R/W	R/W	R/W	R/W	R/W	R/W
POR	0	1	0	1	0	0	1	1

Bit 7~3 **WE4~WE0**: WDT function software control

10101: Disable

01010: Enable

Other values: Reset MCU

When these bits are changed to any other values by the environmental noise to reset the microcontroller, the reset operation will be activated after a delay time,  $t_{SRESET}$ , and the WRF bit in the RSTFC register will be set to 1 to indicate the reset source.

Bit 2~0 **WS2~WS0**: WDT time-out period selection

000:  $2^8/f_{LIRC}$

001:  $2^9/f_{LIRC}$

010:  $2^{10}/f_{LIRC}$

011:  $2^{11}/f_{LIRC}$

100:  $2^{12}/f_{LIRC}$

101:  $2^{13}/f_{LIRC}$

110:  $2^{14}/f_{LIRC}$

111:  $2^{15}/f_{LIRC}$

These three bits determine the division ratio of the Watchdog Timer source clock, which in turn determines the timeout period.

#### • RSTFC Register

Bit	7	6	5	4	3	2	1	0
Name	—	—	—	—	—	LVRF	LRF	WRF
R/W	—	—	—	—	—	R/W	R/W	R/W
POR	—	—	—	—	—	x	0	0

"x": unknown

Bit 7~3 Unimplemented, read as "0"

Bit 2 **LVRF**: LVR function reset flag

Described elsewhere

Bit 1 **LRF**: LVR control register software reset flag

Described elsewhere

Bit 0 **WRF**: WDT control register software reset flag  
 0: Not occurred  
 1: Occurred

This bit is set to 1 by the WDT Control register software reset and cleared by the application program. Note that this bit can only be cleared to 0 by the application program.

### Watchdog Timer Operation

The Watchdog Timer operates by providing a device reset when its timer overflows. This means that in the application program and during normal operation the user has to strategically clear the Watchdog Timer before it overflows to prevent the Watchdog Timer from executing a reset. This is done using the clear watchdog instruction. If the program malfunctions for whatever reason, jumps to an unknown location, or enters an endless loop, the clear WDT instruction will not be executed in the correct manner, in which case the Watchdog Timer will overflow and reset the device. There are five bits, WE4~WE0, in the WDTC register to offer the enable/disable control and reset control of the Watchdog Timer. The WDT function will be disabled when the WE4~WE0 bits are set to a value of 10101B while the WDT function will be enabled if the WE4~WE0 bits are equal to 01010B. If the WE4~WE0 bits are set to any other values, other than 01010B and 10101B, it will reset the device after a delay time,  $t_{SRESET}$ . After power on these bits will have a value of 01010B.

WE4~WE0 Bits	WDT Function
10101B	Disable
01010B	Enable
Any other value	Reset MCU

#### Watchdog Timer Enable/Disable Control

Under normal program operation, a Watchdog Timer time-out will initialise a device reset and set the status bit TO. However, if the system is in the SLEEP or IDLE Mode, when a Watchdog Timer time-out occurs, the TO and PDF bits in the status register will be set high and only the Program Counter and Stack Pointer will be reset. Three methods can be adopted to clear the contents of the Watchdog Timer. The first is a WDT software reset, which means a certain value except 01010B and 10101B written into the WE4~WE0 bits, the second is using the Watchdog Timer software clear instruction, the third is via a HALT instruction.

There is only one method of using software instruction to clear the Watchdog Timer. That is to use the single “CLR WDT” instruction to clear the WDT.

The maximum time-out period is when the  $2^{18}$  division ratio is selected. As an example, with a 32kHz LIRC oscillator as its source clock, this will give a maximum watchdog period of around 1 second for the  $2^{15}$  division ratio, and a minimum timeout of 8ms for the  $2^8$  division ration.

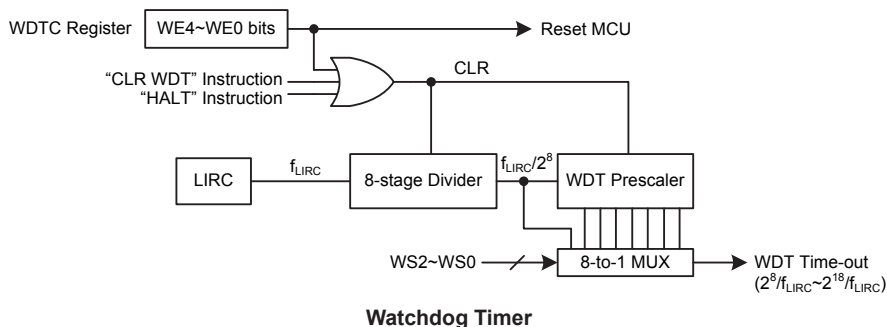

## Reset and Initialisation

A reset function is a fundamental part of any microcontroller ensuring that the device can be set to some predetermined condition irrespective of outside parameters. The most important reset condition is after power is first applied to the microcontroller. In this case, internal circuitry will ensure that the microcontroller, after a short delay, will be in a well-defined state and ready to execute the first program instruction. After this power-on reset, certain important internal registers will be set to defined states before the program commences. One of these registers is the Program Counter, which will be reset to zero forcing the microcontroller to begin program execution from the lowest Program Memory address.

In addition to the power-on reset, another reset exists in the form of a Low Voltage Reset, LVR, where a full reset is implemented in situations where the power supply voltage falls below a certain threshold. Another type of reset is when the Watchdog Timer overflows and resets the microcontroller. All types of reset operations result in different register conditions being setup.

### Reset Functions

There are several ways in which a microcontroller reset can occur through events occurring internally:

#### Power-on Reset

The most fundamental and unavoidable reset is the one that occurs after power is first applied to the microcontroller. As well as ensuring that the Program Memory begins execution from the first memory address, a power-on reset also ensures that certain other registers are preset to known conditions. All the I/O port and port control registers will power up in a high condition ensuring that all pins will be first set to inputs.

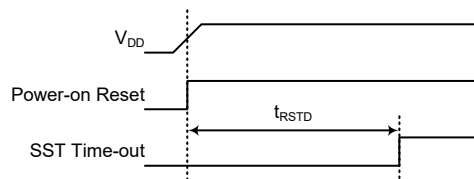

Note:  $t_{RSTD}$  is power-on delay specified in System Start Up Time Characteristics.

**Power-on Reset Timing Chart**

#### Low Voltage Reset – LVR

The microcontroller contains a low voltage reset circuit in order to monitor the supply voltage of the device and provides an MCU reset should the value fall below a certain predefined level.

The LVR function can be enabled or disabled by the LVRC control register. If the LVRC control register is configured to enable the LVR, the LVR function will be always enabled with a specific LVR voltage  $V_{LVR}$  in the FAST/SLOW mode. If the supply voltage of the device drops to within a range of  $0.9V \sim V_{LVR}$  such as might occur when changing the battery in battery powered applications, the LVR will automatically reset the device internally and the LVRF bit in the RSTFC register will also be set to 1. For a valid LVR signal, a low supply voltage, i.e., a voltage in the range between  $0.9V \sim V_{LVR}$  must exist for a time greater than that specified by  $t_{LVR}$  in the LVR Electrical Characteristics. If the low supply voltage state does not exceed this value, the LVR will ignore the low supply voltage and will not perform a reset function. The actual  $V_{LVR}$  value is fixed at 2.1V by the LVS7~LVS0 bits in the LVRC register. If the LVS7~LVS0 bits are changed to some different values, other than 01011010B and 10100101B, by environmental noise, the LVR will reset the device after a delay time,  $t_{SRESET}$ . When this happens, the LRF bit in the RSTFC register will be set to 1. After power on the register will have the value of 01011010B. Note that the LVR function will be automatically disabled when the device enters the SLEEP/IDLE mode.

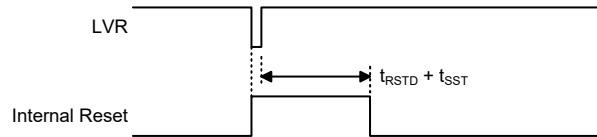

Note:  $t_{RSTD}$  is power-on delay specified in System Start Up Time Characteristics.

**Low Voltage Reset Timing Chart**

• **LVRC Register**

Bit	7	6	5	4	3	2	1	0
Name	LVS7	LVS6	LVS5	LVS4	LVS3	LVS2	LVS1	LVS0
R/W	R/W	R/W	R/W	R/W	R/W	R/W	R/W	R/W
POR	0	1	0	1	1	0	1	0

Bit 7~0 **LVS7~LVS0**: LVR Voltage Select control  
 01011010: 2.1V  
 10100101: Disable

Any other value: Generates MCU reset – register is reset to POR value

When an actual low voltage condition occurs, as specified by the defined LVR voltage value, an MCU reset will be generated. The reset operation will be activated after the low voltage condition keeps more than a  $t_{LVR}$  time. In this situation the register contents will remain the same after such a reset occurs.

Any register value, other than 01011010B and 10100101B, will also result in the generation of an MCU reset. The reset operation will be activated after a delay time,  $t_{SRESET}$ . However in this situation the register contents will be reset to the POR value.

• **RSTFC Register**

Bit	7	6	5	4	3	2	1	0
Name	—	—	—	—	—	LVRF	LRF	WRF
R/W	—	—	—	—	—	R/W	R/W	R/W
POR	—	—	—	—	—	x	0	0

“x”: unknown

Bit 7~3 Unimplemented, read as “0”

Bit 2 **LVRF**: LVR function reset flag  
 0: Not occurred  
 1: Occurred

This bit is set to 1 when a specific Low Voltage Reset situation condition occurs. This bit can only be cleared to 0 by the application program.

Bit 1 **LRF**: LVR control register software reset flag  
 0: Not occurred  
 1: Occurred

This bit is set to 1 if the LVRC register contains any non-defined LVR voltage register values. This in effect acts like a software-reset function. This bit can only be cleared to 0 by the application program.

Bit 0 **WRF**: WDT control register software reset flag  
 Described elsewhere

**Watchdog Time-out Reset during Normal Operation**

When the Watchdog time-out Reset during normal operation occurs, the Watchdog time-out flag TO will be set to “1”.

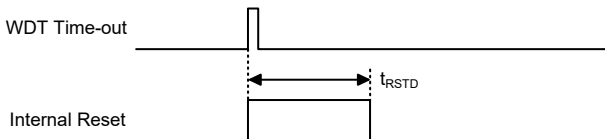

Note:  $t_{RSTD}$  is power-on delay specified in System Start Up Time Characteristics.

**WDT Time-out Reset during Normal Operation Timing Chart**

**Watchdog Time-out Reset during SLEEP or IDLE Mode**

The Watchdog time-out Reset during SLEEP or IDLE Mode is a little different from other kinds of reset. Most of the conditions remain unchanged except that the Program Counter and the Stack Pointer will be cleared to “0” and the TO and PDF flags will be set to “1”. Refer to the System Start Up Time Characteristics for  $t_{SST}$  details.

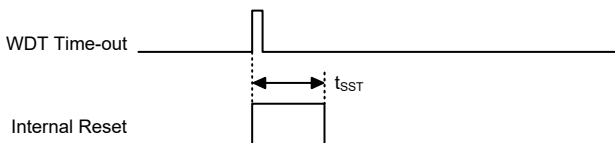

**WDT Time-out Reset during SLEEP or IDLE Timing Chart**

**Reset Initial Conditions**

The different types of reset described affect the reset flags in different ways. These flags, known as PDF and TO are located in the status register and are controlled by various microcontroller operations, such as the SLEEP or IDLE Mode function or Watchdog Timer. The reset flags are shown in the table:

TO	PDF	RESET Conditions
0	0	Power-on reset
u	u	LVR reset during FAST or SLOW Mode operation
1	u	WDT time-out reset during FAST or SLOW Mode operation
1	1	WDT time-out reset during IDLE or SLEEP Mode operation

“u”: unchanged

The following table indicates the way in which the various components of the microcontroller are affected after a power-on reset occurs.

Item	Condition After RESET
Program Counter	Reset to zero
Interrupts	All interrupts will be disabled
WDT, Time Bases	Clear after reset, WDT begins counting
Timer Modules	Timer Modules will be turned off
Input/Output Ports	I/O ports will be setup as inputs
Stack Pointer	Stack Pointer will point to the top of the stack

The different kinds of resets all affect the internal registers of the microcontroller in different ways. To ensure reliable continuation of normal program execution after a reset occurs, it is important to know what condition the microcontroller is in after a particular reset occurs. The following table describes how each type of reset affects each of the microcontroller internal registers.

Register Name	Power On Reset	LVR Reset (Normal Operation)	WDT Time-out (Normal Operation)	WDT Time-out (IDLE/SLEEP)
IAR0	x x x x x x x x	u u u u u u u u	u u u u u u u u	u u u u u u u u
MP0	x x x x x x x x	u u u u u u u u	u u u u u u u u	u u u u u u u u
IAR1	x x x x x x x x	u u u u u u u u	u u u u u u u u	u u u u u u u u
MP1	x x x x x x x x	u u u u u u u u	u u u u u u u u	u u u u u u u u
BP	- - - - - 0	- - - - - 0	- - - - - 0	- - - - - u
ACC	x x x x x x x x	u u u u u u u u	u u u u u u u u	u u u u u u u u
PCL	0 0 0 0 0 0 0 0	0 0 0 0 0 0 0 0	0 0 0 0 0 0 0 0	0 0 0 0 0 0 0 0
TBLP	x x x x x x x x	u u u u u u u u	u u u u u u u u	u u u u u u u u
TBLH	- x x x x x x x	- u u u u u u u	- u u u u u u u	- u u u u u u u
TBHP	- - - - x x x x	- - - - u u u u	- - - - u u u u	- - - - u u u u
STATUS	- - 0 0 x x x x	- - u u u u u u	- - 1 u u u u u	- - 1 1 u u u u
RSTFC	- - - - - x 0 0	- - - - - 1 u u	- - - - - u u u	- - - - - u u u
SADOL	x x x x - - - -	x x x x - - - -	x x x x - - - -	u u u u - - - - (ADRF5=0)
				u u u u u u u u (ADRF5=1)
SADOH	x x x x x x x x	x x x x x x x x	x x x x x x x x	u u u u u u u u (ADRF5=0)
				- - - - u u u u (ADRF5=1)
SADC0	0 0 0 0 0 0 0 0	0 0 0 0 0 0 0 0	0 0 0 0 0 0 0 0	u u u u u u u u
SADC1	0 0 0 0 0 0 0 0	0 0 0 0 0 0 0 0	0 0 0 0 0 0 0 0	u u u u u u u u
PA	1 1 1 1 1 1 1 1	1 1 1 1 1 1 1 1	1 1 1 1 1 1 1 1	u u u u u u u u
PAC	1 1 1 1 1 1 1 1	1 1 1 1 1 1 1 1	1 1 1 1 1 1 1 1	u u u u u u u u
PAPU	0 0 0 0 0 0 0 0	0 0 0 0 0 0 0 0	0 0 0 0 0 0 0 0	u u u u u u u u
PAWU	0 0 0 0 0 0 0 0	0 0 0 0 0 0 0 0	0 0 0 0 0 0 0 0	u u u u u u u u
IECC	0 0 0 0 0 0 0 0	0 0 0 0 0 0 0 0	0 0 0 0 0 0 0 0	u u u u u u u u
PB	1 1 1 1 1 1 1 1	1 1 1 1 1 1 1 1	1 1 1 1 1 1 1 1	u u u u u u u u
PBC	1 1 1 1 1 1 1 1	1 1 1 1 1 1 1 1	1 1 1 1 1 1 1 1	u u u u u u u u
PBPU	0 0 0 0 0 0 0 0	0 0 0 0 0 0 0 0	0 0 0 0 0 0 0 0	u u u u u u u u
PC	- 1 1 1 1 1 1 1 1	- 1 1 1 1 1 1 1 1	- 1 1 1 1 1 1 1 1	- u u u u u u u u
PCC	- 1 1 1 1 1 1 1 1	- 1 1 1 1 1 1 1 1	- 1 1 1 1 1 1 1 1	- u u u u u u u u
PCPU	- 0 0 0 0 0 0 0 0	- 0 0 0 0 0 0 0 0	- 0 0 0 0 0 0 0 0	- u u u u u u u u
SCOMC	- 0 0 0 - - - -	- 0 0 0 - - - -	- 0 0 0 - - - -	- u u u - - - -
DA0L	0 1 0 0 0 0 0 0	0 1 0 0 0 0 0 0	0 1 0 0 0 0 0 0	u u u u u u u u
DA0H	- - 0 0 0 0 0 0	- - 0 0 0 0 0 0	- - 0 0 0 0 0 0	- - u u u u u u
DA1L	0 0 0 0 0 0 0 0	0 0 0 0 0 0 0 0	0 0 0 0 0 0 0 0	u u u u u u u u
DA1H	- - - - 1 0 0 0	- - - - 1 0 0 0	- - - - 1 0 0 0	- - - - u u u u
DAOPC	1 1 0 - - - 0 0	1 1 0 - - - 0 0	1 1 0 - - - 0 0	u u u - - - u u
OPVOS	0 - 1 0 0 0 0 0	0 - 1 0 0 0 0 0	0 - 1 0 0 0 0 0	u - u u u u u u
CRCCR	- - - - - 0	- - - - - 0	- - - - - 0	- - - - - u
CRCIN	0 0 0 0 0 0 0 0	0 0 0 0 0 0 0 0	0 0 0 0 0 0 0 0	u u u u u u u u
CRCDL	0 0 0 0 0 0 0 0	0 0 0 0 0 0 0 0	0 0 0 0 0 0 0 0	u u u u u u u u
CRCDH	0 0 0 0 0 0 0 0	0 0 0 0 0 0 0 0	0 0 0 0 0 0 0 0	u u u u u u u u
CTMC0	0 0 0 0 0 0 0 0	0 0 0 0 0 0 0 0	0 0 0 0 0 0 0 0	u u u u u u u u
CTMC1	0 0 0 0 0 0 0 0	0 0 0 0 0 0 0 0	0 0 0 0 0 0 0 0	u u u u u u u u
CTMDL	0 0 0 0 0 0 0 0	0 0 0 0 0 0 0 0	0 0 0 0 0 0 0 0	u u u u u u u u
CTMDH	- - - - - 0 0	- - - - - 0 0	- - - - - 0 0	- - - - - u u
CTMAL	0 0 0 0 0 0 0 0	0 0 0 0 0 0 0 0	0 0 0 0 0 0 0 0	u u u u u u u u
CTMAH	- - - - - 0 0	- - - - - 0 0	- - - - - 0 0	- - - - - u u

Register Name	Power On Reset	LVR Reset (Normal Operation)	WDT Time-out (Normal Operation)	WDT Time-out (IDLE/SLEEP)
ECR	0000 0000	0000 0000	0000 0000	uuuu uuuu
EAR	---0 0000	---0 0000	---0 0000	---u uuuu
ED0L	0000 0000	0000 0000	0000 0000	uuuu uuuu
ED0H	-000 0000	-000 0000	-000 0000	-uuu uuuu
ED1L	0000 0000	0000 0000	0000 0000	uuuu uuuu
ED1H	-000 0000	-000 0000	-000 0000	-uuu uuuu
ED2L	0000 0000	0000 0000	0000 0000	uuuu uuuu
ED2H	-000 0000	-000 0000	-000 0000	-uuu uuuu
ED3L	0000 0000	0000 0000	0000 0000	uuuu uuuu
ED3H	-000 0000	-000 0000	-000 0000	-uuu uuuu
LVRC	0101 1010	uuuu uuuu	0101 1010	uuuu uuuu
WDTC	0101 0011	0101 0011	0101 0011	uuuu uuuu
SCC	000- --00	000- --00	000- --00	uuu- --uu
HIRCC	---- --0 1	---- --0 1	---- --0 1	---- --uu
PSCR	---- --0 0	---- --0 0	---- --0 0	---- --uu
STMC0	0000 0000	0000 0000	0000 0000	uuuu uuuu
STMC1	0000 0000	0000 0000	0000 0000	uuuu uuuu
STMDL	0000 0000	0000 0000	0000 0000	uuuu uuuu
STMDH	---- --0 0	---- --0 0	---- --0 0	---- --uu
STMAL	0000 0000	0000 0000	0000 0000	uuuu uuuu
STMAH	---- --0 0	---- --0 0	---- --0 0	---- --uu
TB0C	0--- -000	0--- -000	0--- -000	u--- -uuu
TB1C	0--- -000	0--- -000	0--- -000	u--- -uuu
SIMC0	1110 0000	1110 0000	1110 0000	uuuu uuuu
SIMC1 (UMD=0)	1000 0001	1000 0001	1000 0001	uuuu uuuu
UUCR1* (UMD=1)	0000 00x0	0000 00x0	0000 00x0	uuuu uuuu
SIMD/UTXR_RXR	xxxx xxxx	xxxx xxxx	xxxx xxxx	uuuu uuuu
SIMA/SIMC2/UUCR2	0000 0000	0000 0000	0000 0000	uuuu uuuu
SIMTOC (UMD=0)	0000 0000	0000 0000	0000 0000	uuuu uuuu
UBRG* (UMD=1)	xxxx xxxx	xxxx xxxx	xxxx xxxx	uuuu uuuu
UUSR	0000 1011	0000 1011	0000 1011	uuuu uuuu
INTC0	-000 0000	-000 0000	-000 0000	-uuu uuuu
INTC1	0000 0000	0000 0000	0000 0000	uuuu uuuu
INTC2	---0 ---0	---0 ---0	---0 ---0	---u uuuu
MFI0	--00 --00	--00 --00	--00 --00	--uu --uu
MFI1	--00 --00	--00 --00	--00 --00	--uu --uu
INTEG	---- 0000	---- 0000	---- 0000	---- uuuu
IFS	---- -000	---- -000	---- -000	---- -uuu
PAS0	0 0-- 0 0--	0 0-- 0 0--	0 0-- 0 0--	uu-- uu--
PAS1	0000 0000	0000 0000	0000 0000	uuuu uuuu
PBS0	0000 0000	0000 0000	0000 0000	uuuu uuuu
PBS1	0000 0000	0000 0000	0000 0000	uuuu uuuu
PCS0	0000 0000	0000 0000	0000 0000	uuuu uuuu
PCS1	--00 0000	--00 0000	--00 0000	--uu uuuu

Note: “u” stands for unchanged

“x” stands for unknown

“-” stands for unimplemented

“\*” The UUCR1 and SIMC1 registers share the same memory address while the UBRG and SIMTOC registers share the same memory address. The default value of the UUCR1 or UBRG register can be obtained when the UMD bit is set high by application program after a reset.

## Input/Output Ports

Holtek microcontrollers offer considerable flexibility on their I/O ports. With the input or output designation of every pin fully under user program control, pull-high selections for all ports and wake-up selections on certain pins, the user is provided with an I/O structure to meet the needs of a wide range of application possibilities.

The device provides bidirectional input/output lines labeled with port names PA~PC. These I/O ports are mapped to the RAM Data Memory with specific addresses as shown in the Special Purpose Data Memory table. All of these I/O ports can be used for input and output operations. For input operation, these ports are non-latching, which means the inputs must be ready at the T2 rising edge of instruction “MOV A, [m]”, where m denotes the port address. For output operation, all the data is latched and remains unchanged until the output latch is rewritten.

Register Name	Bit							
	7	6	5	4	3	2	1	0
PA	PA7	PA6	PA5	PA4	PA3	PA2	PA1	PA0
PAC	PAC7	PAC6	PAC5	PAC4	PAC3	PAC2	PAC1	PAC0
PAPU	PAPU7	PAPU6	PAPU5	PAPU4	PAPU3	PAPU2	PAPU1	PAPU0
PAWU	PAWU7	PAWU6	PAWU5	PAWU4	PAWU3	PAWU2	PAWU1	PAWU0
PB	PB7	PB6	PB5	PB4	PB3	PB2	PB1	PB0
PBC	PBC7	PBC6	PBC5	PBC4	PBC3	PBC2	PBC1	PBC0
PBPU	PBPU7	PBPU6	PBPU5	PBPU4	PBPU3	PBPU2	PBPU1	PBPU0
PC	—	PC6	PC5	PC4	PC3	PC2	PC1	PC0
PCC	—	PCC6	PCC5	PCC4	PCC3	PCC2	PCC1	PCC0
PCPU	—	PCPU6	PCPU5	PCPU4	PCPU3	PCPU2	PCPU1	PCPU0

“—”: Unimplemented, read as “0”

### I/O Logic Function Register List

## Pull-high Resistors

Many product applications require pull-high resistors for their switch inputs usually requiring the use of an external resistor. To eliminate the need for these external resistors, all I/O pins, when configured as a digital input have the capability of being connected to an internal pull-high resistor. These pull-high resistors are selected using registers, namely PAPU~PCPU, and are implemented using weak PMOS transistors.

Note that the pull-high resistor can be controlled by the relevant pull-high control register only when the pin-shared functional pin is selected as a digital input or NMOS output. Otherwise, the pull-high resistors cannot be enabled.

### • PxPU Register

Bit	7	6	5	4	3	2	1	0
Name	PxPU7	PxPU6	PxPU5	PxPU4	PxPU3	PxPU2	PxPU1	PxPU0
R/W	R/W	R/W	R/W	R/W	R/W	R/W	R/W	R/W
POR	0	0	0	0	0	0	0	0

**PxPU<sub>n</sub>**: I/O Port x Pin pull-high function control

0: Disable

1: Enable

The PxPU<sub>n</sub> bit is used to control the pin pull-high function. Here the “x” can be A, B and C. However, the actual available bits for each I/O Port may be different.

## Port A Wake-up

The HALT instruction forces the microcontroller into the SLEEP or IDLE Mode which preserves power, a feature that is important for battery and other low-power applications. Various methods exist to wake-up the microcontroller, one of which is to change the logic condition on one of the Port A pins from high to low. This function is especially suitable for applications that can be woken up via external switches. Each pin on Port A can be selected individually to have this wake-up feature using the PAWU register.

Note that the wake-up function can be controlled by the wake-up control registers only when the pin is selected as a general purpose input and the MCU enters the IDLE or SLEEP mode.

### • PAWU Register

Bit	7	6	5	4	3	2	1	0
Name	PAWU7	PAWU6	PAWU5	PAWU4	PAWU3	PAWU2	PAWU1	PAWU0
R/W	R/W	R/W	R/W	R/W	R/W	R/W	R/W	R/W
POR	0	0	0	0	0	0	0	0

Bit 7~0      **PAWU7~PAWU0**: PA7~PA0 wake-up function control  
 0: Disable  
 1: Enable

## I/O Port Control Registers

Each I/O port has its own control register known as PAC~PCC, to control the input/output configuration. With this control register, each CMOS output or input can be reconfigured dynamically under software control. Each pin of the I/O ports is directly mapped to a bit in its associated port control register. For the I/O pin to function as an input, the corresponding bit of the control register must be written as a “1”. This will then allow the logic state of the input pin to be directly read by instructions. When the corresponding bit of the control register is written as a “0”, the I/O pin will be setup as a CMOS output. If the pin is currently setup as an output, instructions can still be used to read the output register. However, it should be noted that the program will in fact only read the status of the output data latch and not the actual logic status of the output pin when the IECM is set to “0”.

### • PxC Register

Bit	7	6	5	4	3	2	1	0
Name	PxC7	PxC6	PxC5	PxC4	PxC3	PxC2	PxC1	PxC0
R/W	R/W	R/W	R/W	R/W	R/W	R/W	R/W	R/W
POR	1	1	1	1	1	1	1	1

**PxCn**: I/O Port x Pin type selection

0: Output  
 1: Input

The PxCn bit is used to control the pin type selection. Here the “x” can be A, B and C. However, the actual available bits for each I/O Port may be different.

## Pin-shared Functions

The flexibility of the microcontroller range is greatly enhanced by the use of pins that have more than one function. Limited numbers of pins can force serious design constraints on designers but by supplying pins with multi-functions, many of these difficulties can be overcome. For these pins, the desired function of the multi-function I/O pins is selected by a series of registers via the application program control.

### Pin-shared Function Selection Registers

The limited number of supplied pins in a package can impose restrictions on the amount of functions a certain device can contain. However by allowing the same pins to share several different functions and providing a means of function selection, a wide range of different functions can be incorporated into even relatively small package sizes. The device includes Port “x” Output Function Selection register “n”, labeled as P<sub>x</sub>S<sub>n</sub>, and Input Function Selection register, labeled as IFS, which can select the desired functions of the multi-function pin-shared pins.

The most important point to note is to make sure that the desired pin-shared function is properly selected and also deselected. For most pin-shared functions, to select the desired pin-shared function, the pin-shared function should first be correctly selected using the corresponding pin-shared control register. After that the corresponding peripheral functional setting should be configured and then the peripheral function can be enabled. However, a special point must be noted for some digital input pins, such as INT0, CTCK, etc., which share the same pin-shared control configuration with their corresponding general purpose I/O functions when setting the relevant pin-shared control bit fields. To select these pin functions, in addition to the necessary pin-shared control and peripheral functional setup aforementioned, they must also be setup as input by setting the corresponding bit in the I/O port control register. To correctly deselect the pin-shared function, the peripheral function should first be disabled and then the corresponding pin-shared function control register can be modified to select other pin-shared functions.

Register Name	Bit							
	7	6	5	4	3	2	1	0
PAS0	PAS07	PAS06	—	—	PAS03	PAS02	—	—
PAS1	PAS17	PAS16	PAS15	PAS14	PAS13	PAS12	PAS11	PAS10
PBS0	PBS07	PBS06	PBS05	PBS04	PBS03	PBS02	PBS01	PBS00
PBS1	PBS17	PBS16	PBS15	PBS14	PBS13	PBS12	PBS11	PBS10
PCS0	PCS07	PCS06	PCS05	PCS04	PCS03	PCS02	PCS01	PCS00
PCS1	—	—	PCS15	PCS14	PCS13	PCS12	PCS11	PCS10
IFS	—	—	—	—	—	IFS2	IFS1	IFS0

Pin-shared Function Selection Register List

#### • PAS0 Register

Bit	7	6	5	4	3	2	1	0
Name	PAS07	PAS06	—	—	PAS03	PAS02	—	—
R/W	R/W	R/W	—	—	R/W	R/W	—	—
POR	0	0	—	—	0	0	—	—

Bit 7~6 **PAS07~PAS06**: PA3 Pin-Shared function selection

00: PA3/CTCK/INT0

01: CTP

10: SDO/TX

11: PA3/CTCK/INT0

Bit 5~4 Unimplemented, read as “0”

Bit 3~2 **PAS03~PAS02**: PA1 Pin-Shared function selection

00: PA1

01: OPA2P

10: PA1

11: PA1

Bit 1~0 Unimplemented, read as “0”

• **PAS1 Register**

Bit	7	6	5	4	3	2	1	0
Name	PAS17	PAS16	PAS15	PAS14	PAS13	PAS12	PAS11	PAS10
R/W	R/W	R/W	R/W	R/W	R/W	R/W	R/W	R/W
POR	0	0	0	0	0	0	0	0

Bit 7~6 **PAS17~PAS16:** PA7 Pin-Shared function selection

00: PA7  
 01: SDO/TX  
 10: PA7  
 11: PA7

Bit 5~4 **PAS15~PAS14:** PA6 Pin-Shared function selection

00: PA6  
 01: STPB  
 10: OPA1P  
 11: PA6

Bit 3~2 **PAS13~PAS12:** PA5 Pin-Shared function selection

00: PA5  
 01: CTPB  
 10: OPA0P  
 11: PA5

Bit 1~0 **PAS11~PAS10:** PA4 Pin-Shared function selection

00: PA4/STCK  
 01: STP  
 10: SDI/SDA/RX  
 11: PA4/STCK

• **PBS0 Register**

Bit	7	6	5	4	3	2	1	0
Name	PBS07	PBS06	PBS05	PBS04	PBS03	PBS02	PBS01	PBS00
R/W	R/W	R/W	R/W	R/W	R/W	R/W	R/W	R/W
POR	0	0	0	0	0	0	0	0

Bit 7~6 **PBS07~PBS06:** PB3 Pin-Shared function selection

00: PB3  
 01: PB3  
 10: PB3  
 11: AN3

Bit 5~4 **PBS05~PBS04:** PB2 Pin-Shared function selection

00: PB2/STPI  
 01: PB2/STPI  
 10: PB2/STPI  
 11: AN2

Bit 3~2 **PBS03~PBS02:** PB1 Pin-Shared function selection

00: PB1  
 01: PB1  
 10: VREF  
 11: AN1

Bit 1~0 **PBS01~PBS00:** PB0 Pin-Shared function selection

00: PB0  
 01: PB0  
 10: PB0  
 11: AN0

• **PBS1 Register**

Bit	7	6	5	4	3	2	1	0
Name	PBS17	PBS16	PBS15	PBS14	PBS13	PBS12	PBS11	PBS10
R/W	R/W	R/W	R/W	R/W	R/W	R/W	R/W	R/W
POR	0	0	0	0	0	0	0	0

Bit 7~6     **PBS17~PBS16:** PB7 Pin-Shared function selection

00: PB7  
01: PB7  
10: PB7  
11: AN7

Bit 5~4     **PBS15~PBS14:** PB6 Pin-Shared function selection

00: PB6/INT1  
01: PB6/INT1  
10: PB6/INT1  
11: AN6

Bit 3~2     **PBS13~PBS12:** PB5 Pin-Shared function selection

00: PB5  
01: PB5  
10: PB5  
11: AN5

Bit 1~0     **PBS11~PBS10:** PB4 Pin-Shared function selection

00: PB4  
01: PB4  
10: PB4  
11: AN4

• **PCS0 Register**

Bit	7	6	5	4	3	2	1	0
Name	PCS07	PCS06	PCS05	PCS04	PCS03	PCS02	PCS01	PCS00
R/W	R/W	R/W	R/W	R/W	R/W	R/W	R/W	R/W
POR	0	0	0	0	0	0	0	0

Bit 7~6     **PCS07~PCS06:** PC3 Pin-Shared function selection

00: PC3  
01: SCOM0  
10: SCK/SCL  
11: PC3

Bit 5~4     **PCS05~PCS04:** PC2 Pin-Shared function selection

00: PC2  
01: SDI/SDA/RX  
10: PC2  
11: PC2

Bit 3~2     **PCS03~PCS02:** PC1 Pin-Shared function selection

00: PC1  
01: SCK/SCL  
10: PC1  
11: AN9

Bit 1~0     **PCS01~PCS00:** PC0 Pin-Shared function selection

00: PC0  
01:  $\overline{SCS}$   
10: PC0  
11: AN8

• **PCS1 Register**

Bit	7	6	5	4	3	2	1	0
Name	—	—	PCS15	PCS14	PCS13	PCS12	PCS11	PCS10
R/W	—	—	R/W	R/W	R/W	R/W	R/W	R/W
POR	—	—	0	0	0	0	0	0

- Bit 7~6 Unimplemented, read as “0”
- Bit 5~4 **PCS15~PCS14**: PC6 Pin-Shared function selection  
 00: PC6  
 01: SCOM3  
 10: PC6  
 11: PC6
- Bit 3~2 **PCS13~PCS12**: PC5 Pin-Shared function selection  
 00: PC5  
 01: SCOM2  
 10: PC5  
 11: PC5
- Bit 1~0 **PCS11~PCS10**: PC4 Pin-Shared function selection  
 00: PC4  
 01: SCOM1  
 10:  $\overline{SCS}$   
 11: PC4

• **IFS Register**

Bit	7	6	5	4	3	2	1	0
Name	—	—	—	—	—	IFS2	IFS1	IFS0
R/W	—	—	—	—	—	R/W	R/W	R/W
POR	—	—	—	—	—	0	0	0

- Bit 7~3 Unimplemented, read as “0”
- Bit 2 **IFS2**: SCK/SCL input source pin selection  
 0: PC1  
 1: PC3
- Bit 1 **IFS1**: SDI/SDA/RX input source pin selection  
 0: PC2  
 1: PA4
- Bit 0 **IFS0**:  $\overline{SCS}$  input source pin selection  
 0: PC0  
 1: PC4

### I/O Pin Structures

The accompanying diagram illustrates the internal structures of the I/O logic function. As the exact logical construction of the I/O pin will differ from this diagram, it is supplied as a guide only to assist with the functional understanding of the logic function I/O pins. The wide range of pin-shared structures does not permit all types to be shown.

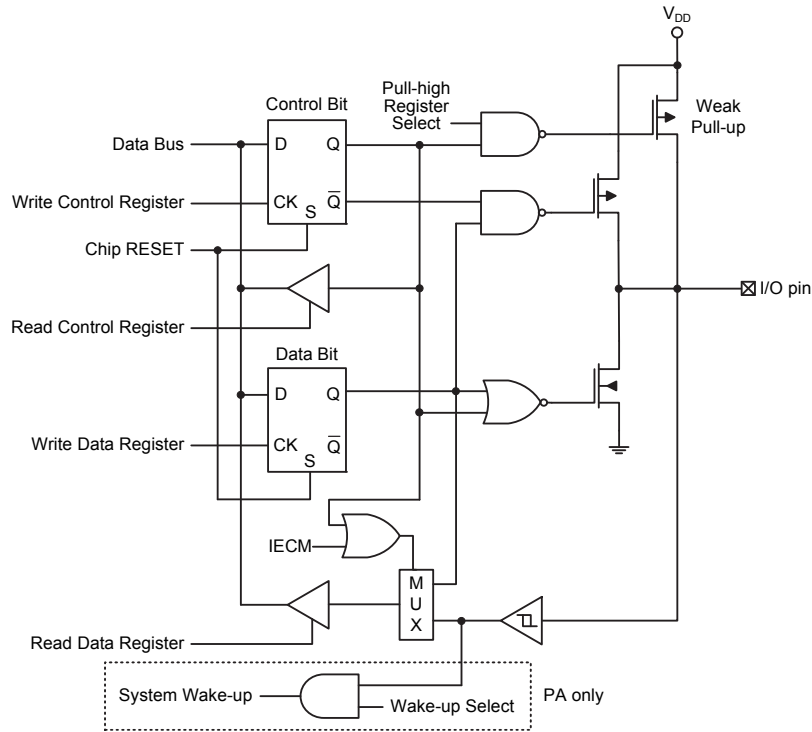

Logic Function Input/Output Structure

### READ PORT Function

The READ PORT function is used to read data from I/O pins, which is specially designed for the IEC 60730 self-diagnostic test on the I/O function and A/D paths. After the self-diagnostic test on the I/O function and A/D paths are completed, users must disable the READ PORT function immediately. In cases other than the I/O function and A/D path self-diagnostic test, it is strongly recommended to disable the READ PORT function to avoid affecting other peripheral functions and causing unexpected consequences.

There is a register, IECC, which is used to control the READ PORT function. When a specific data pattern, “11001010”, is written into the IECC register, the internal signal named IECM will be set high to enable the READ PORT function. If the READ PORT function is enabled, the reading path is from the I/O pins. The value on the corresponding pins will be passed to the accumulator ACC when the read port instruction “mov a, Px” is executed, where the “x” stands for the corresponding I/O port name. However, when the IECC register content is set to any other values rather than “11001010”, the IECM internal signal will be cleared to 0 to disable the READ PORT function, and the reading path will be from the data latch or I/O pins. If the READ PORT function is disabled, the pin function will operate as the selected pin-shared function.

• **IECC Register**

Bit	7	6	5	4	3	2	1	0
Name	IECS7	IECS6	IECS5	IECS4	IECS3	IECS2	IECS1	IECS0
R/W	R/W	R/W	R/W	R/W	R/W	R/W	R/W	R/W
POR	0	0	0	0	0	0	0	0

Bit 7~0     **IECS7~IECS0:** READ PORT function enable control bit 7~ bit 0  
 11001010: IECS7=1 – READ PORT function is enabled  
 Others: IECS7=0 – READ PORT function is disabled

READ PORT Function	Disabled		Enabled	
	1	0	1	0
Port Control Register Bit – PxC.n				
I/O Function	Pin value	Data latch value	Pin value	
A/D Function	0			

Note: The value on the above table is the content of the ACC register after “mov a, Px” instruction is executed where “x” means the relevant port name.

The additional function of the READ PORT mode is to check the A/D path. When the READ PORT function is disabled, the A/D path from the external pin to the internal analog input will be switched off if the A/D input pin function is not selected by the corresponding selection bits. For the MCU with A/D converter channels, the desired A/D channel can be switched on by properly configuring the external analog input channel selection bits in the A/D Control Register together with the corresponding analog input pin function is selected. However, the additional function of the READ PORT mode is to force the A/D path to be switched on. As shown in the following example, when the AN0 is selected as the analog input channel as the READ PORT function is enabled, the AN0 analog input path will be switched on even if the AN0 analog input pin function is not selected. In this way, the AN0 analog input path can be examined by internally connecting the digital output on this shared pin with the AN0 analog input pin switch and then converting the corresponding digital data without any external analog input voltage connected.

Note that the A/D converter reference voltage should be equal to the I/O power supply voltage when examining the A/D path using the READ PORT function.

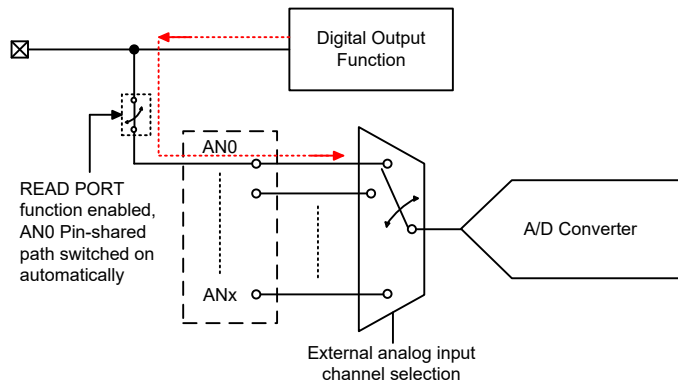

**A/D Channel Input Path Internal Connection**

## Programming Considerations

Within the user program, one of the first things to consider is port initialisation. After a reset, all of the I/O data and port control registers will be set high. This means that all I/O pins will default to an input state, the level of which depends on the other connected circuitry and whether pull-high selections have been chosen. If the port control registers are then programmed to setup some pins as outputs, these output pins will have an initial high output value unless the associated port data registers are first programmed. Selecting which pins are inputs and which are outputs can be achieved byte-wide by loading the correct values into the appropriate port control register or by programming individual bits in the port control register using the “SET [m].i” and “CLR [m].i” instructions. Note that when using these bit control instructions, a read-modify-write operation takes place. The microcontroller must first read in the data on the entire port, modify it to the required new bit values and then rewrite this data back to the output ports.

Port A has the additional capability of providing wake-up function. When the device is in the SLEEP or IDLE Mode, various methods are available to wake the device up. One of these is a high to low transition of any of the Port A pins. Single or multiple pins on Port A can be setup to have this function.

## Timer Modules – TM

One of the most fundamental functions in any microcontroller device is the ability to control and measure time. To implement time related functions each device includes several Timer Modules, abbreviated to the name TM. The TMs are multi-purpose timing units and serve to provide operations such as Timer/Counter, Input Capture, Compare Match Output and Single Pulse Output as well as being the functional unit for the generation of PWM signals. Each of the TMs has two individual interrupts. The addition of input and output pins for each TM ensures that users are provided with timing units with a wide and flexible range of features.

The common features of the different TM types are described here with more detailed information provided in the individual Compact and Standard TM sections.

### Introduction

The device contains two TMs and each individual TM can be categorised as a certain type, namely Compact Type TM or Standard Type TM. Although similar in nature, the different TM types vary in their feature complexity. The common features to all of the Compact and Standard TMs will be described in this section. The detailed operation regarding each of the TM types will be described in separate sections. The main features and differences between the two types of TMs are summarised in the accompanying table.

Function	CTM	STM
Timer/Counter	√	√
Input Capture	—	√
Compare Match Output	√	√
PWM Output	√	√
Single Pulse Output	—	√
PWM Alignment	Edge	Edge
PWM Adjustment Period & Duty	Duty or Period	Duty or Period

**TM Function Summary**

## TM Operation

The different types of TM offer a diverse range of functions, from simple timing operations to PWM signal generation. The key to understanding how the TM operates is to see it in terms of a free running counter whose value is then compared with the value of pre-programmed internal comparators. When the free running counter has the same value as the pre-programmed comparator, known as a compare match situation, a TM interrupt signal will be generated which can clear the counter and perhaps also change the condition of the TM output pin. The internal TM counter is driven by a user selectable clock source, which can be an internal clock or an external pin.

## TM Clock Source

The clock source which drives the main counter in each TM can originate from various sources. The selection of the required clock source is implemented using the xTCK2~xTCK0 bits in the xTM control registers, where “x” stands for C or S type TM. The clock source can be a ratio of the system clock  $f_{SYS}$  or the internal high clock  $f_{IH}$ , the  $f_{SUB}$  clock source or the external xTCK pin. The xTCK pin clock source is used to allow an external signal to drive the TM as an external clock source or for event counting.

## TM Interrupts

The Compact and Standard type TMs each have two internal interrupts, one for each of the internal comparator A or comparator P, which generate a TM interrupt when a compare match condition occurs. When a TM interrupt is generated it can be used to clear the counter and also to change the state of the TM output pin.

## TM External Pins

Each of the TMs, irrespective of what type, has one input pin with the label xTCK while the Standard type TM has another input pin with the label STPI. The xTM input pin, xTCK, is essentially a clock source for the xTM and is selected using the xTCK2~xTCK0 bits in the xTMC0 register. This external TM input pin allows an external clock source to drive the internal TM. The xTCK input pin can be chosen to have either a rising or falling active edge. The STCK pin is also used as the external trigger input pin in single pulse output mode. The other STM input pin, STPI, is the capture input whose active edge can be a rising edge, a falling edge or both rising and falling edges and the active edge transition type is selected using the STIO1~STIO0 bits in the STMC1 register.

The TMs each have two output pins with the label xTP and xTPB. When the TM is in the Compare Match Output Mode, these pins can be controlled by the TM to switch to a high or low level or to toggle when a compare match situation occurs. The external xTP and xTPB output pins are also the pins where the TM generates the PWM output waveform.

As the TM input and output pins are pin-shared with other functions, the TM input and output functions must first be setup using relevant pin-shared function selection register. The details of the pin-shared function selection are described in the pin-shared function section.

CTM		STM	
Input	Output	Input	Output
CTCK	CTP, CTPB	STCK, STPI	STP, STPB

**TM External Pins**

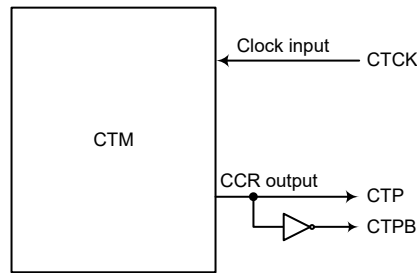

CTM Function Pin Block Diagram

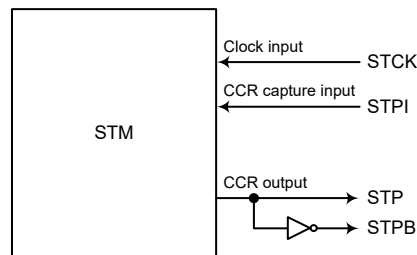

STM Function Pin Block Diagram

### Programming Considerations

The TM Counter Registers and the Capture/Compare CCRA registers, all have a low and high byte structure. The high bytes can be directly accessed, but as the low bytes can only be accessed via an internal 8-bit buffer, reading or writing to these register pairs must be carried out in a specific way. The important point to note is that data transfer to and from the 8-bit buffer and its related low byte only takes place when a write or read operation to its corresponding high byte is executed.

As the CCRA register is implemented in the way shown in the following diagram and accessing these register pairs is carried out in a specific way as described above, it is recommended to use the "MOV" instruction to access the CCRA low byte registers, named xTMAL, using the following access procedures. Accessing the CCRA low byte register without following these access procedures will result in unpredictable values.

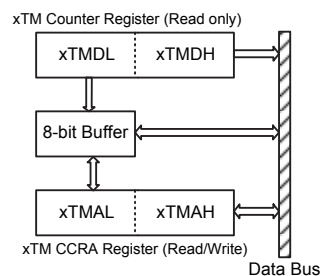

The following steps show the read and write procedures:

- Writing Data to CCRA
  - ♦ Step 1. Write data to Low Byte xTMAL
    - Note that here data is only written to the 8-bit buffer.
  - ♦ Step 2. Write data to High Byte xTMAH
    - Here data is written directly to the high byte registers and simultaneously data is latched from the 8-bit buffer to the Low Byte registers.

- Reading Data from the Counter Registers and or CCRA
  - ♦ Step 1. Read data from the High Byte xTMDH or xTMAH
    - Here data is read directly from the High Byte registers and simultaneously data is latched from the Low Byte register into the 8-bit buffer.
  - ♦ Step 2. Read data from the Low Byte xTMDL or xTMAL
    - This step reads data from the 8-bit buffer.

## Compact Type TM – CTM

The Compact Type TM contains three operating modes, which are Compare Match Output, Timer/Event Counter and PWM Output modes. The Compact Type TM can also be controlled with an external input pin and can drive two external output pins.

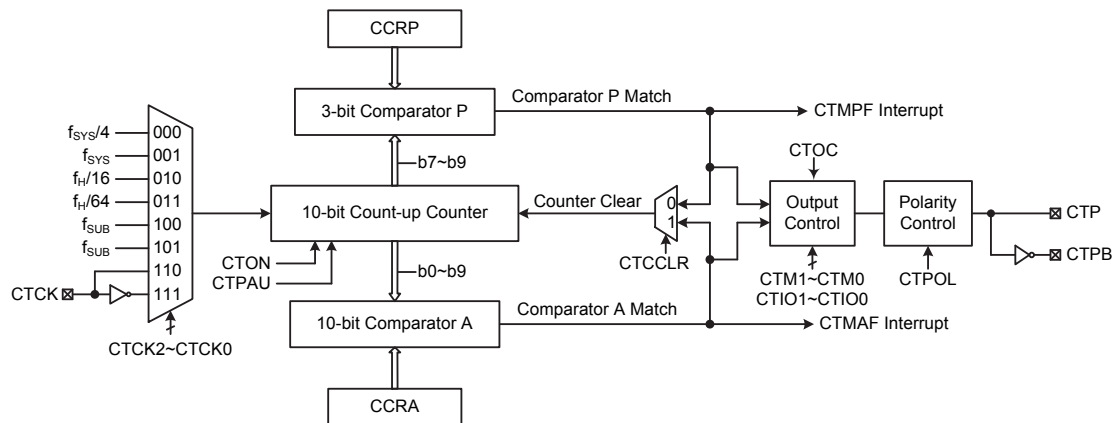

Note: The CTM external pins are pin-shared with other functions, so before using the CTM function, the pin-shared function registers must be set properly to enable the CTM pin function.

**Compact Type TM Block Diagram**

### Compact Type TM Operation

The size of Compact Type TM is 10-bit wide and its core is a 10-bit count-up counter which is driven by a user selectable internal or external clock source. There are also two internal comparators with the names, Comparator A and Comparator P. These comparators will compare the value in the counter with CCRP and CCRA registers. The CCRP comparator is 3-bit wide whose value is compared with the highest 3 bits in the counter while the CCRA is the 10 bits and therefore compares all counter bits.

The only way of changing the value of the 10-bit counter using the application program, is to clear the counter by changing the CTON bit from low to high. The counter will also be cleared automatically by a counter overflow or a compare match with one of its associated comparators. When these conditions occur, a CTM interrupt signal will also usually be generated. The Compact Type TM can operate in a number of different operational modes, can be driven by different clock sources including an input pin and can also control two output pins. All operating setup conditions are selected using relevant internal registers.

### Compact Type TM Register Description

Overall operation of the Compact Type TM is controlled using a series of registers. A read only register pair exists to store the internal counter 10-bit value, while a read/write register pair exists to store the internal 10-bit CCRA value. The remaining two registers are control registers which setup the different operating and control modes as well as three CCRP bits.

Register Name	Bit							
	7	6	5	4	3	2	1	0
CTMC0	CTPAU	CTCK2	CTCK1	CTCK0	CTON	CTRP2	CTRP1	CTRP0
CTMC1	CTM1	CTM0	CTIO1	CTIO0	CTOC	CTPOL	CTDPX	CTCCLR
CTMDL	D7	D6	D5	D4	D3	D2	D1	D0
CTMDH	—	—	—	—	—	—	D9	D8
CTMAL	D7	D6	D5	D4	D3	D2	D1	D0
CTMAH	—	—	—	—	—	—	D9	D8

**10-bit Compact Type TM Register List**

• **CTMC0 Register**

Bit	7	6	5	4	3	2	1	0
Name	CTPAU	CTCK2	CTCK1	CTCK0	CTON	CTRP2	CTRP1	CTRP0
R/W	R/W	R/W	R/W	R/W	R/W	R/W	R/W	R/W
POR	0	0	0	0	0	0	0	0

**Bit 7 CTPAU:** CTM Counter Pause control  
0: Run  
1: Pause

The counter can be paused by setting this bit high. Clearing the bit to zero restores normal counter operation. When in a Pause condition the CTM will remain powered up and continue to consume power. The counter will retain its residual value when this bit changes from low to high and resume counting from this value when the bit changes to a low value again.

**Bit 6~4 CTCK2~CTCK0:** Select CTM Counter clock  
000:  $f_{SYS}/4$   
001:  $f_{SYS}$   
010:  $f_H/16$   
011:  $f_H/64$   
100:  $f_{SUB}$   
101:  $f_{SUB}$   
110: CTCK rising edge clock  
111: CTCK falling edge clock

These three bits are used to select the clock source for the CTM. The external pin clock source can be chosen to be active on the rising or falling edge. The clock source  $f_{SYS}$  is the system clock, while  $f_H$  and  $f_{SUB}$  are other internal clocks, the details of which can be found in the oscillator section.

**Bit 3 CTON:** CTM Counter On/Off control  
0: Off  
1: On

This bit controls the overall on/off function of the CTM. Setting the bit high enables the counter to run while clearing the bit disables the CTM. Clearing this bit to zero will stop the counter from counting and turn off the CTM which will reduce its power consumption. When the bit changes state from low to high the internal counter value will be reset to zero, however when the bit changes from high to low, the internal counter will retain its residual value until the bit returns high again. If the CTM is in the Compare Match Output Mode or the PWM Output Mode then the CTM output pin will be reset to its initial condition, as specified by the CTOC bit, when the CTON bit changes from low to high.

Bit 2~0     **CTRP2~CTRP0**: CTM CCRP 3-bit register, compared with the CTM counter bit 9 ~ bit 7  
 Comparator P match period=  
     000: 1024 CTM clocks  
     001: 128 CTM clocks  
     010: 256 CTM clocks  
     011: 384 CTM clocks  
     100: 512 CTM clocks  
     101: 640 CTM clocks  
     110: 768 CTM clocks  
     111: 896 CTM clocks

These three bits are used to setup the value on the internal CCRP 3-bit register, which are then compared with the internal counter's highest three bits. The result of this comparison can be selected to clear the internal counter if the CTCCLR bit is set to zero. Setting the CTCCLR bit to zero ensures that a compare match with the CCRP values will reset the internal counter. As the CCRP bits are only compared with the highest three counter bits, the compare values exist in 128 clock cycle multiples. Clearing all three bits to zero is in effect allowing the counter to overflow at its maximum value.

• **CTMC1 Register**

Bit	7	6	5	4	3	2	1	0
Name	CTM1	CTM0	CTIO1	CTIO0	CTOC	CTPOL	CTDPX	CTCCLR
R/W	R/W	R/W	R/W	R/W	R/W	R/W	R/W	R/W
POR	0	0	0	0	0	0	0	0

Bit 7~6     **CTM1~CTM0**: Select CTM Operating Mode  
     00: Compare Match Output Mode  
     01: Undefined  
     10: PWM Output Mode  
     11: Timer/Counter Mode

These bits setup the required operating mode for the CTM. To ensure reliable operation the CTM should be switched off before any changes are made to the CTM1 and CTM0 bits. In the Timer/Counter Mode, the CTM output pin state is undefined.

Bit 5~4     **CTIO1~CTIO0**: Select CTM external pin function  
 Compare Match Output Mode  
     00: No change  
     01: Output low  
     10: Output high  
     11: Toggle output  
 PWM Output Mode  
     00: PWM output inactive state  
     01: PWM output active state  
     10: PWM output  
     11: Undefined  
 Timer/Counter Mode  
     Unused

These two bits are used to determine how the CTM external pin changes state when a certain condition is reached. The function that these bits select depends upon in which mode the CTM is running.

In the Compare Match Output Mode, the CTIO1 and CTIO0 bits determine how the CTM output pin changes state when a compare match occurs from the Comparator A. The CTM output pin can be setup to switch high, switch low or to toggle its present state when a compare match occurs from the Comparator A. When the bits are both zero, then no change will take place on the output. The initial value of the CTM output pin should be setup using the CTOC bit in the CTMC1 register. Note that the output level requested by the CTIO1 and CTIO0 bits must be different from the initial value

setup using the CTOC bit otherwise no change will occur on the CTM output pin when a compare match occurs. After the CTM output pin changes state, it can be reset to its initial level by changing the level of the CTON bit from low to high.

In the PWM Output Mode, the CTIO1 and CTIO0 bits determine how the CTM output pin changes state when a certain compare match condition occurs. The PWM output function is modified by changing these two bits. It is necessary to only change the values of the CTIO1 and CTIO0 bits only after the CTM has been switched off. Unpredictable PWM outputs will occur if the CTIO1 and CTIO0 bits are changed when the CTM is running.

Bit 3 **CTOC**: CTM CTP Output control

Compare Match Output Mode

0: Initial low

1: Initial high

PWM Output Mode/Single Pulse Output Mode

0: Active low

1: Active high

This is the output control bit for the CTM output pin. Its operation depends upon whether CTM is being used in the Compare Match Output Mode or in the PWM Output Mode. It has no effect if the CTM is in the Timer/Counter Mode. In the Compare Match Output Mode it determines the logic level of the CTM output pin before a compare match occurs. In the PWM Output Mode it determines if the PWM signal is active high or active low.

Bit 2 **CTPOL**: CTM CTP Output polarity control

0: Non-invert

1: Invert

This bit controls the polarity of the CTP output pin. When the bit is set high the CTM output pin will be inverted and not inverted when the bit is zero. It has no effect if the CTM is in the Timer/Counter Mode.

Bit 1 **CTDPX**: CTM PWM duty/period control

0: CCRP – period; CCRA – duty

1: CCRP – duty; CCRA – period

This bit determines which of the CCRA and CCRP registers are used for period and duty control of the PWM waveform.

Bit 0 **CTCCLR**: CTM Counter Clear condition selection

0: CTM Comparator P match

1: CTM Comparator A match

This bit is used to select the method which clears the counter. Remember that the Compact TM contains two comparators, Comparator A and Comparator P, either of which can be selected to clear the internal counter. With the CTCCLR bit set high, the counter will be cleared when a compare match occurs from the Comparator A. When the bit is low, the counter will be cleared when a compare match occurs from the Comparator P or with a counter overflow. A counter overflow clearing method can only be implemented if the CCRP bits are all cleared to zero. The CTCCLR bit is not used in the PWM Output mode.

• **CTMDL Register**

Bit	7	6	5	4	3	2	1	0
Name	D7	D6	D5	D4	D3	D2	D1	D0
R/W	R	R	R	R	R	R	R	R
POR	0	0	0	0	0	0	0	0

Bit 7~0      **D7~D0**: CTM Counter Low Byte Register bit 7 ~ bit 0  
 CTM 10-bit Counter bit 7 ~ bit 0

• **CTMDH Register**

Bit	7	6	5	4	3	2	1	0
Name	—	—	—	—	—	—	D9	D8
R/W	—	—	—	—	—	—	R	R
POR	—	—	—	—	—	—	0	0

Bit 7~2      Unimplemented, read as “0”  
 Bit 1~0      **D9~D8**: CTM Counter High Byte Register bit 1 ~ bit 0  
 CTM 10-bit Counter bit 9 ~ bit 8

• **CTMAL Register**

Bit	7	6	5	4	3	2	1	0
Name	D7	D6	D5	D4	D3	D2	D1	D0
R/W	R/W	R/W	R/W	R/W	R/W	R/W	R/W	R/W
POR	0	0	0	0	0	0	0	0

Bit 7~0      **D7~D0**: CTM CCRA Low Byte Register bit 7 ~ bit 0  
 CTM 10-bit CCRA bit 7 ~ bit 0

• **CTMAH Register**

Bit	7	6	5	4	3	2	1	0
Name	—	—	—	—	—	—	D9	D8
R/W	—	—	—	—	—	—	R/W	R/W
POR	—	—	—	—	—	—	0	0

Bit 7~2      Unimplemented, read as “0”  
 Bit 1~0      **D9~D8**: CTM CCRA High Byte Register bit 7 ~ bit 0  
 CTM 10-bit CCRA bit 9 ~ bit 8

## Compact Type TM Operation Modes

The Compact Type TM can operate in one of three operating modes, Compare Match Output Mode, PWM Output Mode or Timer/Counter Mode. The operating mode is selected using the CTM1 and CTM0 bits in the CTMC1 register.

### Compare Match Output Mode

To select this mode, bits CTM1 and CTM0 in the CTMC1 register, should be set to 00 respectively. In this mode once the counter is enabled and running it can be cleared by three methods. These are a counter overflow, a compare match from Comparator A and a compare match from Comparator P. When the CTCCLR bit is low, there are two ways in which the counter can be cleared. One is when a compare match from Comparator P, the other is when the CCRP bits are all zero which allows the counter to overflow. Here both CTMAF and CTMPF interrupt request flags for Comparator A and Comparator P respectively, will both be generated.

If the CTCCLR bit in the CTMC1 register is high then the counter will be cleared when a compare match occurs from Comparator A. However, here only the CTMAF interrupt request flag will be generated even if the value of the CCRP bits is less than that of the CCRA registers. Therefore when CTCCLR is high no CTMPF interrupt request flag will be generated. If the CCRA bits are all zero, the counter will overflow when it reaches its maximum 10-bit, 3FF Hex, value. However, here the CTMAF interrupt request flag will not be generated.

As the name of the mode suggests, after a comparison is made, the CTM output pin, will change state. The CTM output pin condition however only changes state when a CTMAF interrupt request flag is generated after a compare match occurs from Comparator A. The CTMPF interrupt request flag, generated from a compare match occurs from Comparator P, will have no effect on the CTM output pin. The way in which the CTM output pin changes state are determined by the condition of the CTIO1 and CTIO0 bits in the CTMC1 register. The CTM output pin can be selected using the CTIO1 and CTIO0 bits to go high, to go low or to toggle from its present condition when a compare match occurs from Comparator A. The initial condition of the CTM output pin, which is setup after the CTON bit changes from low to high, is setup using the CTOC bit. Note that if the CTIO1 and CTIO0 bits are zero then no pin change will take place.

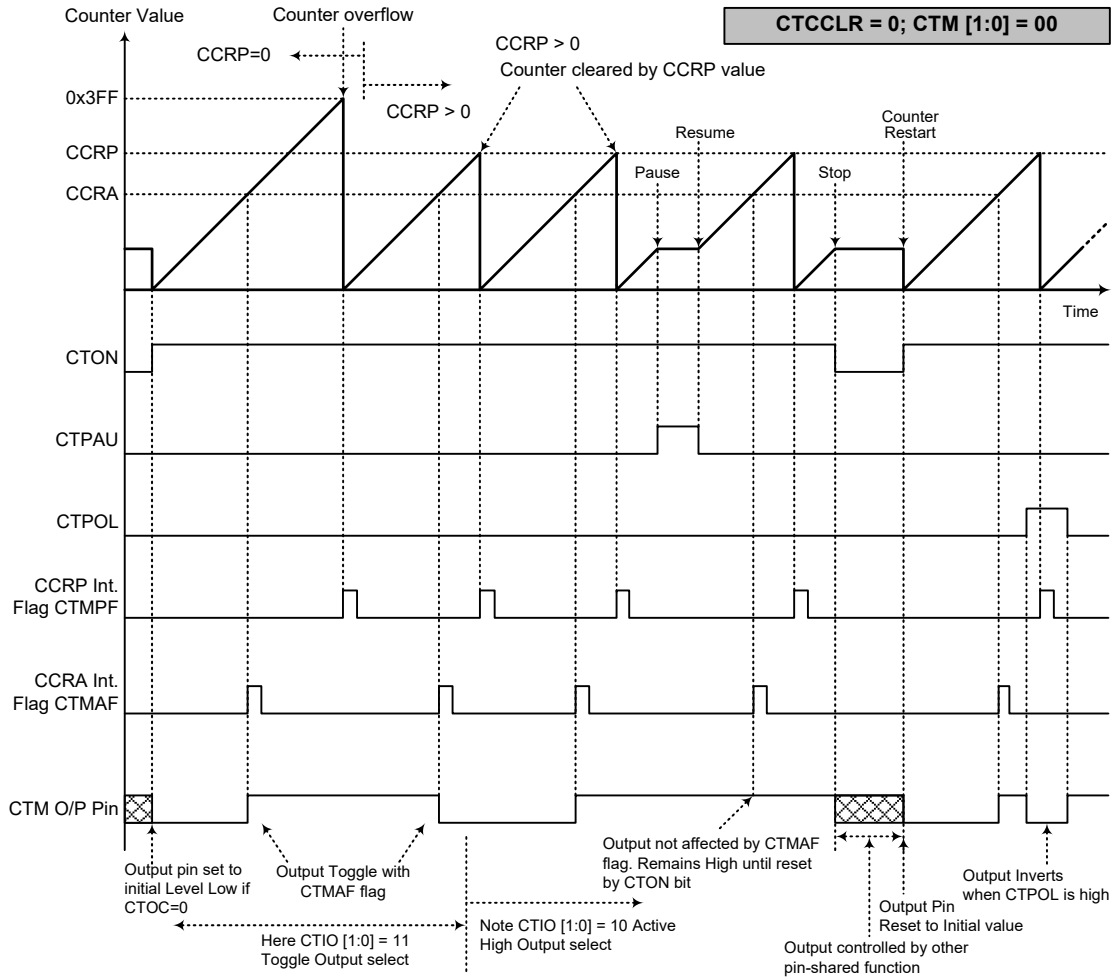

**Compare Match Output Mode – CTCCLR=0**

- Note: 1. With CTCCLR=0 a Comparator P match will clear the counter  
 2. The CTM output pin is controlled only by the CTMAF flag  
 3. The output pin is reset to its initial state by a CTON bit rising edge

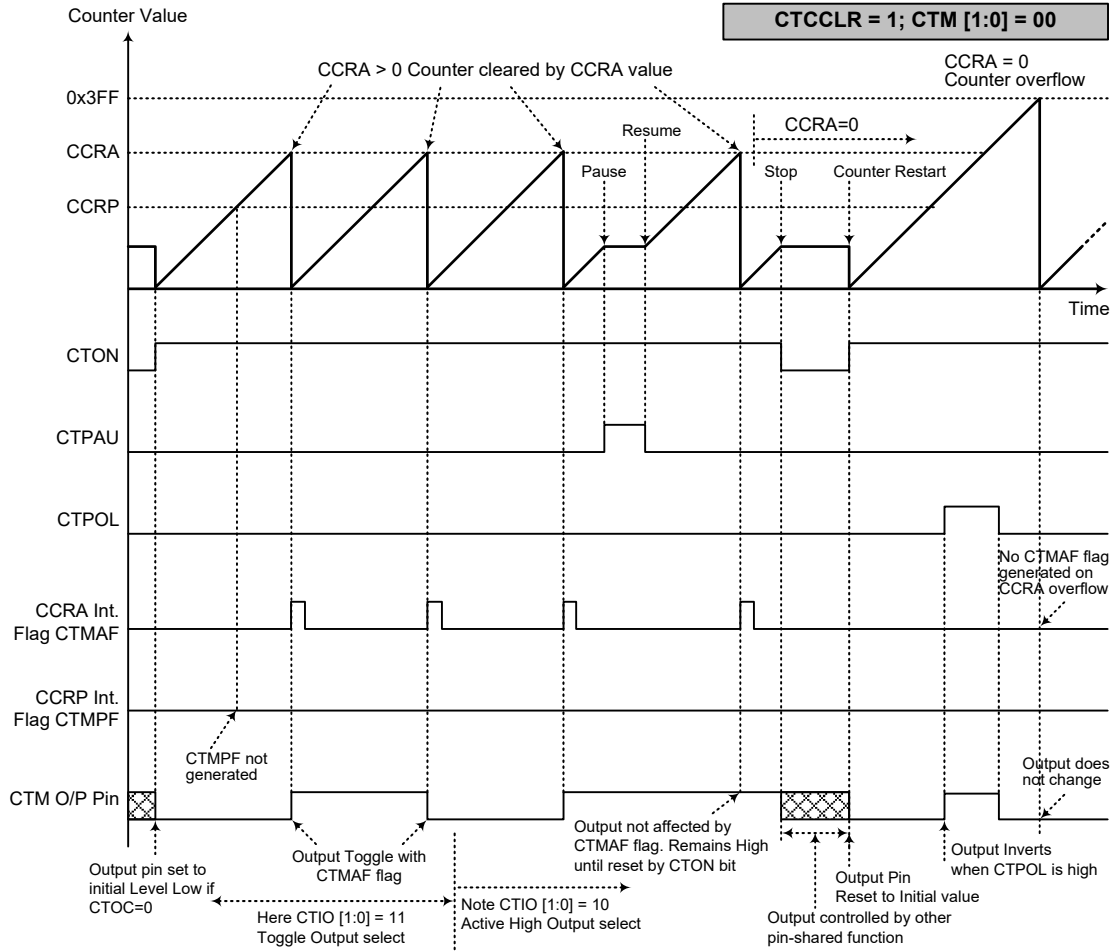

**Compare Match Output Mode – CTCCLR=1**

- Note:
1. With CTCCLR=1 a Comparator A match will clear the counter
  2. The CTM output pin is controlled only by the CTMAF flag
  3. The output pin is reset to its initial state by a CTON bit rising edge
  4. A CTMPF flag is not generated when CTCCLR=1

**Timer/Counter Mode**

To select this mode, bits CTM1 and CTM0 in the CTMC1 register should be set to 11 respectively. The Timer/Counter Mode operates in an identical way to the Compare Match Output Mode generating the same interrupt flags. The exception is that in the Timer/Counter Mode the CTM output pin is not used. Therefore the above description and Timing Diagrams for the Compare Match Output Mode can be used to understand its function. As the CTM output pin is not used in this mode, the pin can be used as a normal I/O pin or other pin-shared function.

**PWM Output Mode**

To select this mode, bits CTM1 and CTM0 in the CTMC1 register should be set to 10 respectively. The PWM function within the CTM is useful for applications which require functions such as motor control, heating control, illumination control, etc. By providing a signal of fixed frequency but of varying duty cycle on the CTM output pin, a square wave AC waveform can be generated with varying equivalent DC RMS values.

As both the period and duty cycle of the PWM waveform can be controlled, the choice of generated waveform is extremely flexible. In the PWM Output Mode, the CTCCLR bit has no effect as the PWM period. Both of the CCRA and CCRP registers are used to generate the PWM waveform, one register is used to clear the internal counter and thus control the PWM waveform frequency, while the other one is used to control the duty cycle. Which register is used to control either frequency or duty cycle is determined using the CTDPIX bit in the CTMC1 register. The PWM waveform frequency and duty cycle can therefore be controlled by the values in the CCRA and CCRP registers.

An interrupt flag, one for each of the CCRA and CCRP, will be generated when a compare match occurs from either Comparator A or Comparator P. The CTOC bit in the CTMC1 register is used to select the required polarity of the PWM waveform while the two CTIO1 and CTIO0 bits are used to enable the PWM output or to force the CTM output pin to a fixed high or low level. The CTPOL bit is used to reverse the polarity of the PWM output waveform.

• **10-bit CTM, PWM Output Mode, Edge-aligned Mode, CTDPIX=0**

CCRP	001b	010b	011b	100b	101b	110b	111b	000b
Period	128	256	384	512	640	768	896	1024
Duty	CCRA							

If  $f_{SYS}=8\text{MHz}$ , CTM clock source is  $f_{SYS}/4$ , CCRP=100b, CCRA=128,

The CTM PWM output frequency= $(f_{SYS}/4)/512=f_{SYS}/2048=4\text{kHz}$ , duty=128/512=25%.

If the Duty value defined by the CCRA register is equal to or greater than the Period value, then the PWM output duty is 100%.

• **10-bit CTM, PWM Output Mode, Edge-aligned Mode, CTDPIX=1**

CCRP	001b	010b	011b	100b	101b	110b	111b	000b
Period	CCRA							
Duty	128	256	384	512	640	768	896	1024

The PWM output period is determined by the CCRA register value together with the CTM clock while the PWM duty cycle is defined by the CCRP register value except when the CCRP value is equal to 0.



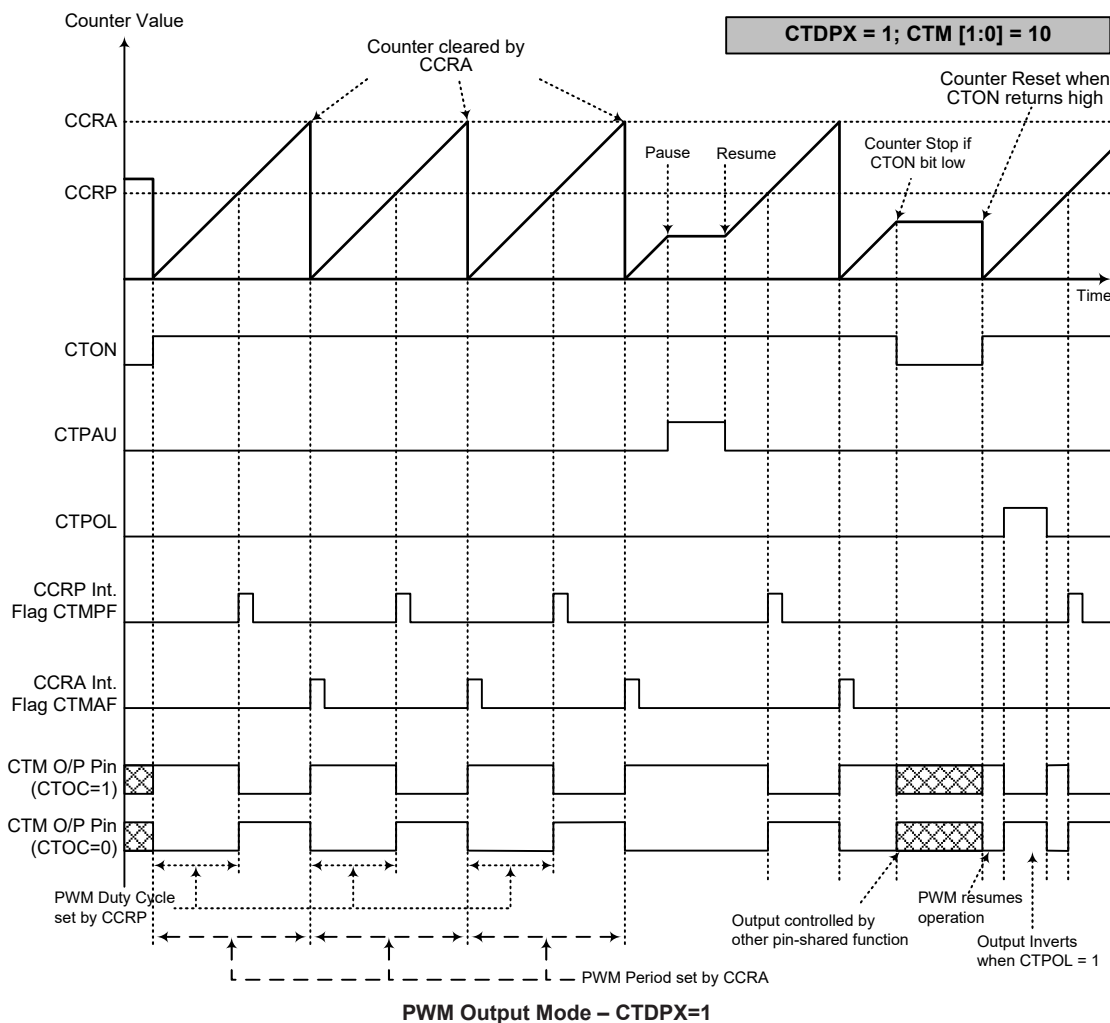

- Note: 1. Here CTDPX=1 – Counter cleared by CCRA  
 2. A counter clear sets the PWM Period  
 3. The internal PWM function continues even when CTIO[1:0]=00 or 01  
 4. The CTCCLR bit has no influence on PWM operation

## Standard Type TM – STM

The Standard Type TM contains five operating modes, which are Compare Match Output, Timer/Event Counter, Capture Input, Single Pulse Output and PWM Output modes. The Standard TM can be controlled with two external input pins and can drive two external output pins.

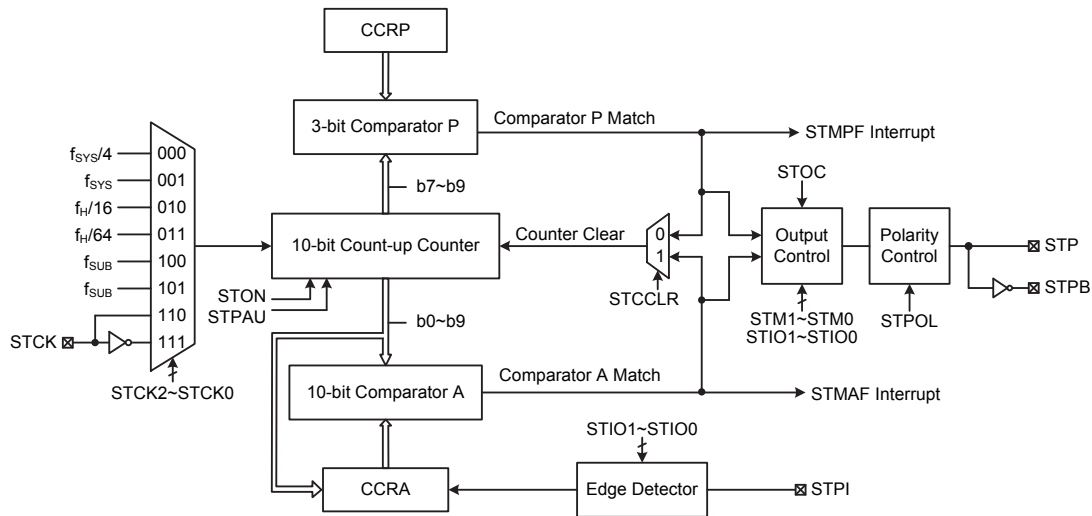

Note: The STM external pins are pin-shared with other functions, so before using the STM function the pin-shared function registers must be set properly to enable the STM pin function.

Standard Type TM Block Diagram

### Standard TM Operation

The size of Standard TM is 10-bit wide and its core is a 10-bit count-up counter which is driven by a user selectable internal or external clock source. There are also two internal comparators with the names, Comparator A and Comparator P. These comparators will compare the value in the counter with CCRP and CCRA registers. The CCRP comparator is 3-bit wide whose value is compared with the highest 3 bits in the counter while the CCRA is the 10 bits and therefore compares all counter bits.

The only way of changing the value of the 10-bit counter using the application program, is to clear the counter by changing the STON bit from low to high. The counter will also be cleared automatically by a counter overflow or a compare match with one of its associated comparators. When these conditions occur, a STM interrupt signal will also usually be generated. The Standard Type TM can operate in a number of different operational modes, can be driven by different clock sources including an input pin and can also control two output pins. All operating setup conditions are selected using relevant internal registers.

### Standard Type TM Register Description

Overall operation of the Standard TM is controlled using a series of registers. A read only register pair exists to store the internal counter 10-bit value, while a read/write register pair exists to store the internal 10-bit CCRA value. The remaining two registers are control registers which setup the different operating and control modes as well as three CCRP bits.

Register Name	Bit							
	7	6	5	4	3	2	1	0
STMC0	STPAU	STCK2	STCK1	STCK0	STON	STRP2	STRP1	STRP0
STMC1	STM1	STM0	STIO1	STIO0	STOC	STPOL	STDPX	STCCLR
STMDL	D7	D6	D5	D4	D3	D2	D1	D0
STMDH	—	—	—	—	—	—	D9	D8
STMAL	D7	D6	D5	D4	D3	D2	D1	D0
STMAH	—	—	—	—	—	—	D9	D8

10-bit Standard TM Register List

• **STMC0 Register**

Bit	7	6	5	4	3	2	1	0
Name	STPAU	STCK2	STCK1	STCK0	STON	STRP2	STRP1	STRP0
R/W	R/W	R/W	R/W	R/W	R/W	R/W	R/W	R/W
POR	0	0	0	0	0	0	0	0

Bit 7 **STPAU**: STM Counter Pause control  
0: Run  
1: Pause

The counter can be paused by setting this bit high. Clearing the bit to zero restores normal counter operation. When in a Pause condition the STM will remain powered up and continue to consume power. The counter will retain its residual value when this bit changes from low to high and resume counting from this value when the bit changes to a low value again.

Bit 6~4 **STCK2~STCK0**: Select STM Counter clock  
000:  $f_{SYS}/4$   
001:  $f_{SYS}$   
010:  $f_H/16$   
011:  $f_H/64$   
100:  $f_{SUB}$   
101:  $f_{SUB}$   
110: STCK rising edge clock  
111: STCK falling edge clock

These three bits are used to select the clock source for the STM. The external pin clock source can be chosen to be active on the rising or falling edge. The clock source  $f_{SYS}$  is the system clock, while  $f_H$  and  $f_{SUB}$  are other internal clocks, the details of which can be found in the oscillator section.

Bit 3 **STON**: STM Counter On/Off control  
0: Off  
1: On

This bit controls the overall on/off function of the STM. Setting the bit high enables the counter to run while clearing the bit disables the STM. Clearing this bit to zero will stop the counter from counting and turn off the STM which will reduce its power consumption. When the bit changes state from low to high the internal counter value will be reset to zero, however when the bit changes from high to low, the internal counter will retain its residual value until the bit returns high again. If the STM is in the Compare Match Output Mode, PWM Output Mode or Single Pulse Output Mode then the STM output pin will be reset to its initial condition, as specified by the STOC bit, when the STON bit changes from low to high.

Bit 2~0     **STRP2~STRP0**: STM CCRP 3-bit register, compared with the STM counter bit 9 ~ bit 7  
 Comparator P Match Period=  
     000: 1024 STM clocks  
     001: 128 STM clocks  
     010: 256 STM clocks  
     011: 384 STM clocks  
     100: 512 STM clocks  
     101: 640 STM clocks  
     110: 768 STM clocks  
     111: 896 STM clocks

These three bits are used to setup the value on the internal CCRP 3-bit register, which are then compared with the internal counter's highest three bits. The result of this comparison can be selected to clear the internal counter if the STCCLR bit is set to zero. Setting the STCCLR bit to zero ensures that a compare match with the CCRP values will reset the internal counter. As the CCRP bits are only compared with the highest three counter bits, the compare values exist in 128 clock cycle multiples. Clearing all three bits to zero is in effect allowing the counter to overflow at its maximum value.

• **STMC1 Register**

Bit	7	6	5	4	3	2	1	0
Name	STM1	STM0	STIO1	STIO0	STOC	STPOL	STDPX	STCCLR
R/W	R/W	R/W	R/W	R/W	R/W	R/W	R/W	R/W
POR	0	0	0	0	0	0	0	0

Bit 7~6     **STM1~STM0**: Select STM Operating Mode  
     00: Compare Match Output Mode  
     01: Capture Input Mode  
     10: PWM Output Mode or Single Pulse Output Mode  
     11: Timer/Counter Mode

These bits setup the required operating mode for the STM. To ensure reliable operation the STM should be switched off before any changes are made to the STM1 and STM0 bits. In the Timer/Counter Mode, the STM output pin state is undefined.

Bit 5~4     **STIO1~STIO0**: Select STM external pin function  
 Compare Match Output Mode  
     00: No change  
     01: Output low  
     10: Output high  
     11: Toggle output  
 PWM Output Mode/Single Pulse Output Mode  
     00: PWM output inactive state  
     01: PWM output active state  
     10: PWM output  
     11: Single Pulse Output  
 Capture Input Mode  
     00: Input capture at rising edge of STPI  
     01: Input capture at falling edge of STPI  
     10: Input capture at rising/falling edge of STPI  
     11: Input capture disabled

Timer/Counter Mode  
 Unused

These two bits are used to determine how the STM external pin changes state when a certain condition is reached. The function that these bits select depends upon in which mode the STM is running.

In the Compare Match Output Mode, the STIO1 and STIO0 bits determine how the STM output pin changes state when a compare match occurs from the Comparator A. The STM output pin can be setup to switch high, switch low or to toggle its present state when a compare match occurs from the Comparator A. When the bits are both zero, then no change will take place on the output. The initial value of the STM output pin should be setup using the STOC bit in the STMC1 register. Note that the output level requested by the STIO1 and STIO0 bits must be different from the initial value setup using the STOC bit otherwise no change will occur on the STM output pin when a compare match occurs. After the STM output pin changes state, it can be reset to its initial level by changing the level of the STON bit from low to high.

In the PWM Output Mode, the STIO1 and STIO0 bits determine how the STM output pin changes state when a certain compare match condition occurs. The PWM output function is modified by changing these two bits. It is necessary to only change the values of the STIO1 and STIO0 bits only after the STM has been switched off. Unpredictable PWM outputs will occur if the STIO1 and STIO0 bits are changed when the STM is running.

Bit 3 **STOC: STM STP Output control**

Compare Match Output Mode

0: Initial low

1: Initial high

PWM Output Mode/Single Pulse Output Mode

0: Active low

1: Active high

This is the output control bit for the STM output pin. Its operation depends upon whether STM is being used in the Compare Match Output Mode or in the PWM Output Mode/Single Pulse Output Mode. It has no effect if the STM is in the Timer/Counter Mode. In the Compare Match Output Mode it determines the logic level of the STM output pin before a compare match occurs. In the PWM Output Mode it determines if the PWM signal is active high or active low. In the Single Pulse Output Mode it determines the logic level of the STM output pin when the STON bit changes from low to high.

Bit 2 **STPOL: STM STP Output polarity control**

0: Non-invert

1: Invert

This bit controls the polarity of the STP output pin. When the bit is set high the STM output pin will be inverted and not inverted when the bit is zero. It has no effect if the STM is in the Timer/Counter Mode.

Bit 1 **STDPX: STM PWM duty/period control**

0: CCRP – period; CCRA – duty

1: CCRP – duty; CCRA – period

This bit determines which of the CCRA and CCRP registers are used for period and duty control of the PWM waveform.

Bit 0 **STCCLR: STM Counter Clear condition selection**

0: Comparator P match

1: Comparator A match

This bit is used to select the method which clears the counter. Remember that the Standard TM contains two comparators, Comparator A and Comparator P, either of which can be selected to clear the internal counter. With the STCCLR bit set high, the counter will be cleared when a compare match occurs from the Comparator A. When the bit is low, the counter will be cleared when a compare match occurs from the Comparator P or with a counter overflow. A counter overflow clearing method can only be implemented if the CCRP bits are all cleared to zero. The STCCLR bit is not used in the PWM Output, Single Pulse Output or Capture Input Mode.

• **STMDL Register**

Bit	7	6	5	4	3	2	1	0
Name	D7	D6	D5	D4	D3	D2	D1	D0
R/W	R	R	R	R	R	R	R	R
POR	0	0	0	0	0	0	0	0

Bit 7~0      **D7~D0**: STM Counter Low Byte Register bit 7 ~ bit 0  
STM 10-bit Counter bit 7 ~ bit 0

• **STMDH Register**

Bit	7	6	5	4	3	2	1	0
Name	—	—	—	—	—	—	D9	D8
R/W	—	—	—	—	—	—	R	R
POR	—	—	—	—	—	—	0	0

Bit 7~2      Unimplemented, read as “0”  
Bit 1~0      **D9~D8**: STM Counter High Byte Register bit 1 ~ bit 0  
STM 10-bit Counter bit 9 ~ bit 8

• **STMAL Register**

Bit	7	6	5	4	3	2	1	0
Name	D7	D6	D5	D4	D3	D2	D1	D0
R/W	R/W	R/W	R/W	R/W	R/W	R/W	R/W	R/W
POR	0	0	0	0	0	0	0	0

Bit 7~0      **D7~D0**: STM CCRA Low Byte Register bit 7 ~ bit 0  
STM 10-bit CCRA bit 7 ~ bit 0

• **STMAH Register**

Bit	7	6	5	4	3	2	1	0
Name	—	—	—	—	—	—	D9	D8
R/W	—	—	—	—	—	—	R/W	R/W
POR	—	—	—	—	—	—	0	0

Bit 7~2      Unimplemented, read as “0”  
Bit 1~0      **D9~D8**: STM CCRA High Byte Register bit 1 ~ bit 0  
STM 10-bit CCRA bit 9 ~ bit 8

## **Standard Type TM Operation Modes**

The Standard Type TM can operate in one of five operating modes, Compare Match Output Mode, PWM Output Mode, Single Pulse Output Mode, Capture Input Mode or Timer/Counter Mode. The operating mode is selected using the STM1 and STM0 bits in the STMC1 register.

### **Compare Match Output Mode**

To select this mode, bits STM1 and STM0 in the STMC1 register, should be set to 00 respectively. In this mode once the counter is enabled and running it can be cleared by three methods. These are a counter overflow, a compare match from Comparator A and a compare match from Comparator P. When the STCCLR bit is low, there are two ways in which the counter can be cleared. One is when a compare match from Comparator P, the other is when the CCRP bits are all zero which allows the counter to overflow. Here both STMAF and STMPF interrupt request flags for Comparator A and Comparator P respectively, will both be generated.

If the STCCLR bit in the STMC1 register is high then the counter will be cleared when a compare match occurs from Comparator A. However, here only the STMAF interrupt request flag will be generated even if the value of the CCRP bits is less than that of the CCRA registers. Therefore when STCCLR is high no STMPF interrupt request flag will be generated. In the Compare Match Output Mode, the CCRA cannot be set to “0”.

If the CCRA bits are all zero, the counter will overflow when it reaches its maximum 3FF Hex, value, however here the STMAF interrupt request flag will not be generated.

As the name of the mode suggests, after a comparison is made, the STM output pin, will change state. The STM output pin condition however only changes state when a STMAF interrupt request flag is generated after a compare match occurs from Comparator A. The STMPF interrupt request flag, generated from a compare match occurs from Comparator P, will have no effect on the STM output pin. The way in which the STM output pin changes state are determined by the condition of the STIO1 and STIO0 bits in the STMC1 register. The STM output pin can be selected using the STIO1 and STIO0 bits to go high, to go low or to toggle from its present condition when a compare match occurs from Comparator A. The initial condition of the STM output pin, which is setup after the STON bit changes from low to high, is setup using the STOC bit. Note that if the STIO1 and STIO0 bits are zero then no pin change will take place.

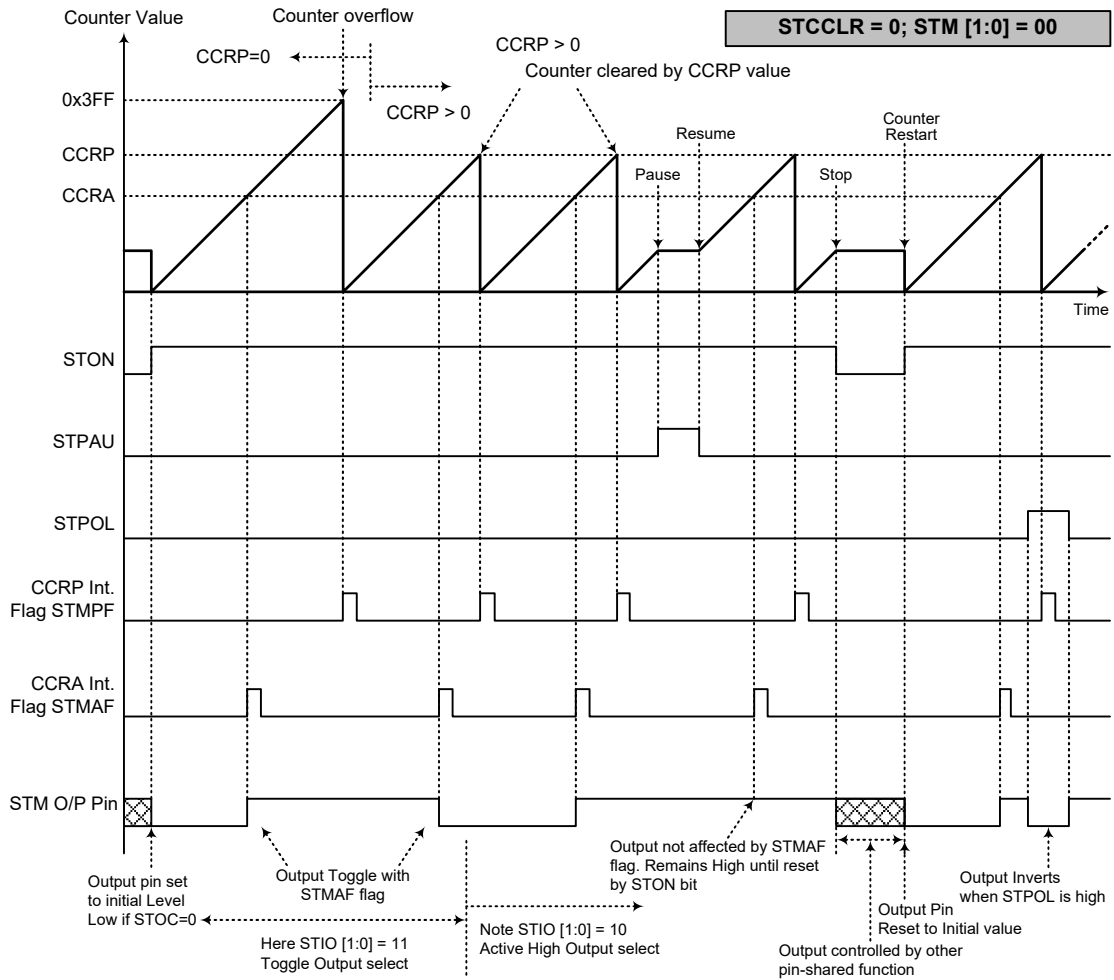

**Compare Match Output Mode – STCCLR=0**

- Note: 1. With STCCLR=0 a Comparator P match will clear the counter  
 2. The STM output pin is controlled only by the STMAF flag  
 3. The output pin is reset to its initial state by a STON bit rising edge

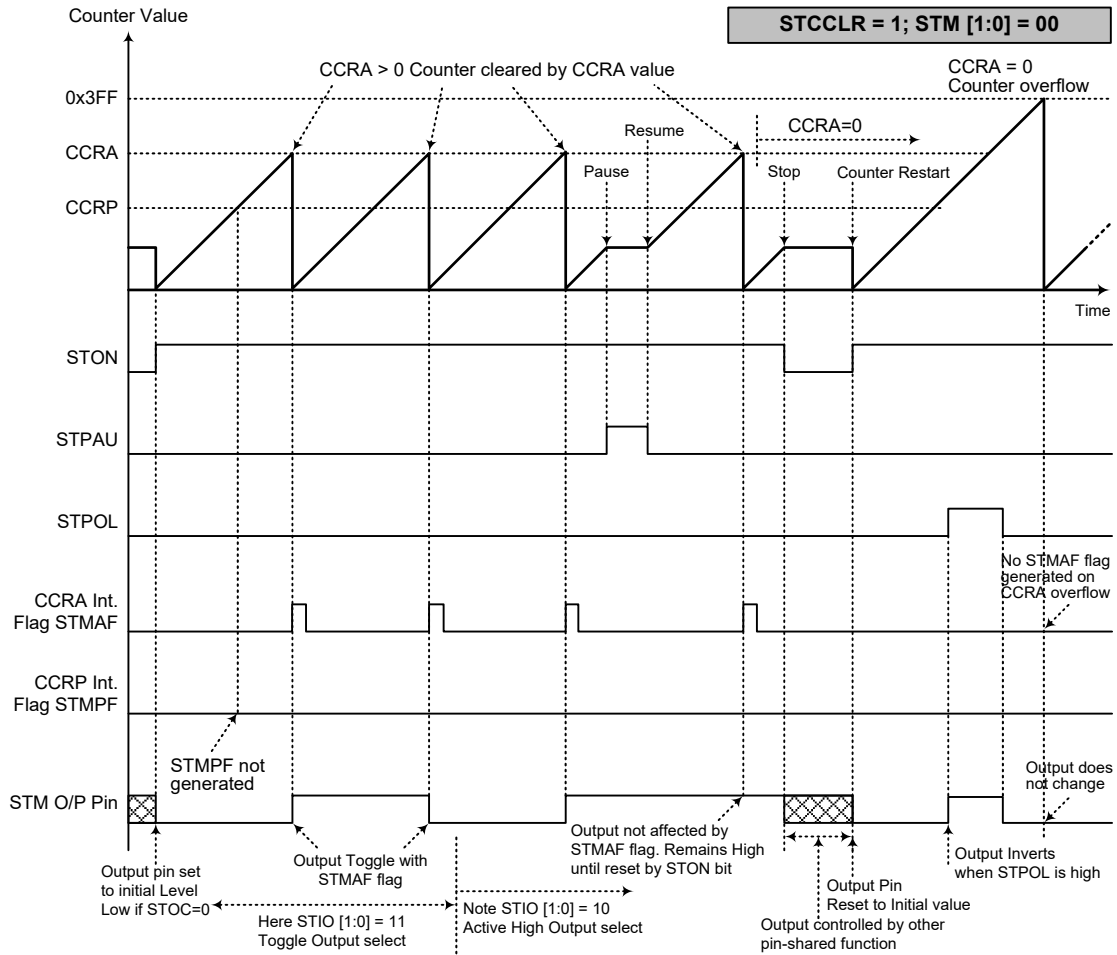

**Compare Match Output Mode – STCCLR=1**

- Note: 1. With STCCLR=1 a Comparator A match will clear the counter  
 2. The STM output pin is controlled only by the STMAF flag  
 3. The output pin is reset to its initial state by a STON bit rising edge  
 4. A STMPF flag is not generated when STCCLR=1

**Timer/Counter Mode**

To select this mode, bits STM1 and STM0 in the STMC1 register should be set to 11 respectively. The Timer/Counter Mode operates in an identical way to the Compare Match Output Mode generating the same interrupt flags. The exception is that in the Timer/Counter Mode the STM output pin is not used. Therefore the above description and Timing Diagrams for the Compare Match Output Mode can be used to understand its function. As the STM output pin is not used in this mode, the pin can be used as a normal I/O pin or other pin-shared function.

**PWM Output Mode**

To select this mode, bits STM1 and STM0 in the STMC1 register should be set to 10 respectively and also the STIO1 and STIO0 bits should be set to 10 respectively. The PWM function within the STM is useful for applications which require functions such as motor control, heating control, illumination control etc. By providing a signal of fixed frequency but of varying duty cycle on the STM output pin, a square wave AC waveform can be generated with varying equivalent DC RMS values.

As both the period and duty cycle of the PWM waveform can be controlled, the choice of generated waveform is extremely flexible. In the PWM Output Mode, the STCCLR bit has no effect as the PWM period. Both of the CCRA and CCRP registers are used to generate the PWM waveform, one register is used to clear the internal counter and thus control the PWM waveform frequency, while the other one is used to control the duty cycle. Which register is used to control either frequency or duty cycle is determined using the STDPX bit in the STMC1 register. The PWM waveform frequency and duty cycle can therefore be controlled by the values in the CCRA and CCRP registers.

An interrupt flag, one for each of the CCRA and CCRP, will be generated when a compare match occurs from either Comparator A or Comparator P. The STOC bit in the STMC1 register is used to select the required polarity of the PWM waveform while the two STIO1 and STIO0 bits are used to enable the PWM output or to force the STM output pin to a fixed high or low level. The STPOL bit is used to reverse the polarity of the PWM output waveform.

• **10-bit STM, PWM Output Mode, Edge-aligned Mode, STDPX=0**

CCRP	001b	010b	011b	100b	101b	110b	111b	000b
Period	128	256	384	512	640	768	896	1024
Duty	CCRA							

If  $f_{SYS}=8\text{MHz}$ , TM clock source is  $f_{SYS}/4$ , CCRP=100b and CCRA=128,

The STM PWM output frequency= $(f_{SYS}/4)/512=f_{SYS}/2048=4\text{kHz}$ , duty=128/512=25%.

If the Duty value defined by the CCRA register is equal to or greater than the Period value, then the PWM output duty is 100%.

• **10-bit STM, PWM Output Mode, Edge-aligned Mode, STDPX=1**

CCRP	001b	010b	011b	100b	101b	110b	111b	000b
Period	CCRA							
Duty	128	256	384	512	640	768	896	1024

The PWM output period is determined by the CCRA register value together with the STM clock while the PWM duty cycle is defined by the CCRP register value.

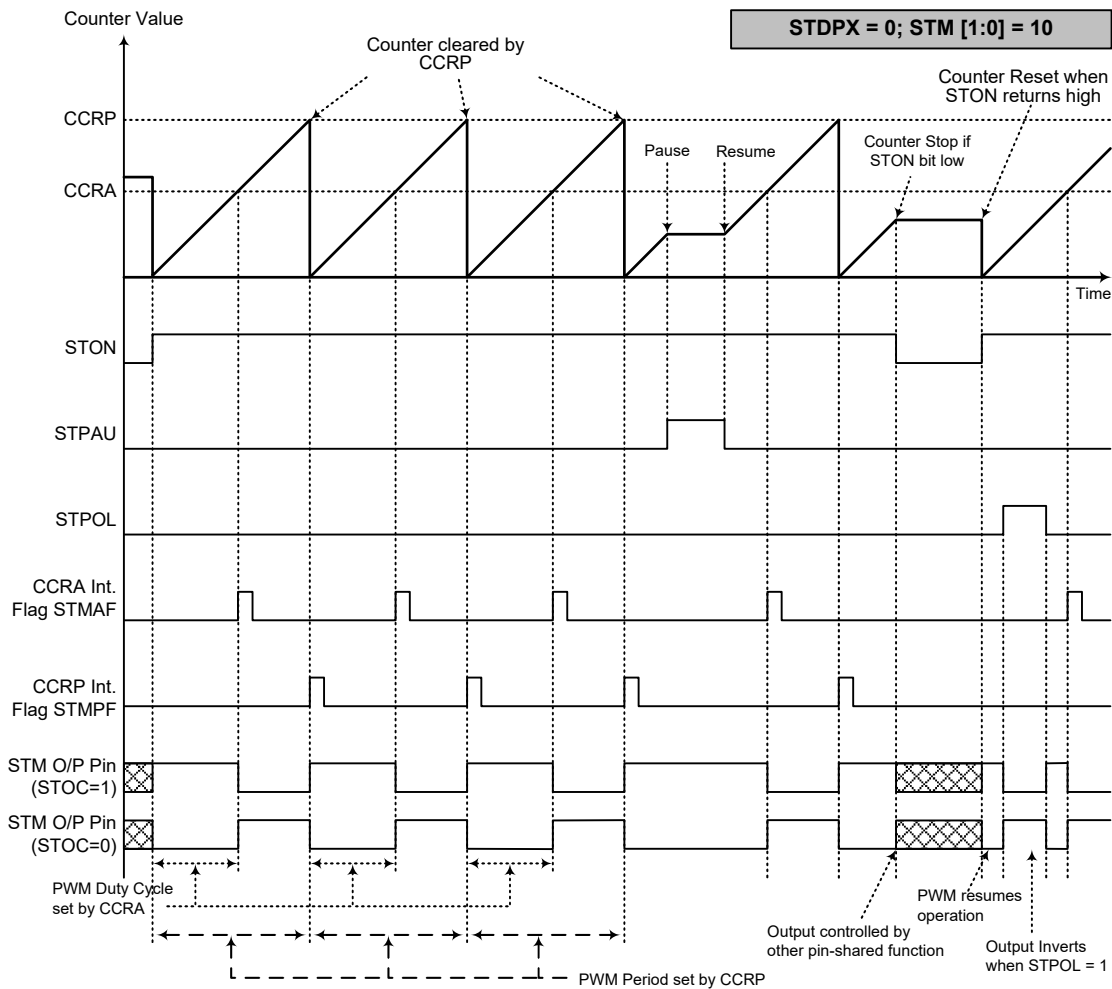

- Note: 1. Here STDPX=0 – Counter cleared by CCRP  
 2. A counter clear sets the PWM Period  
 3. The internal PWM function continues running even when STIO[1:0]=00 or 01  
 4. The STCCLR bit has no influence on PWM operation

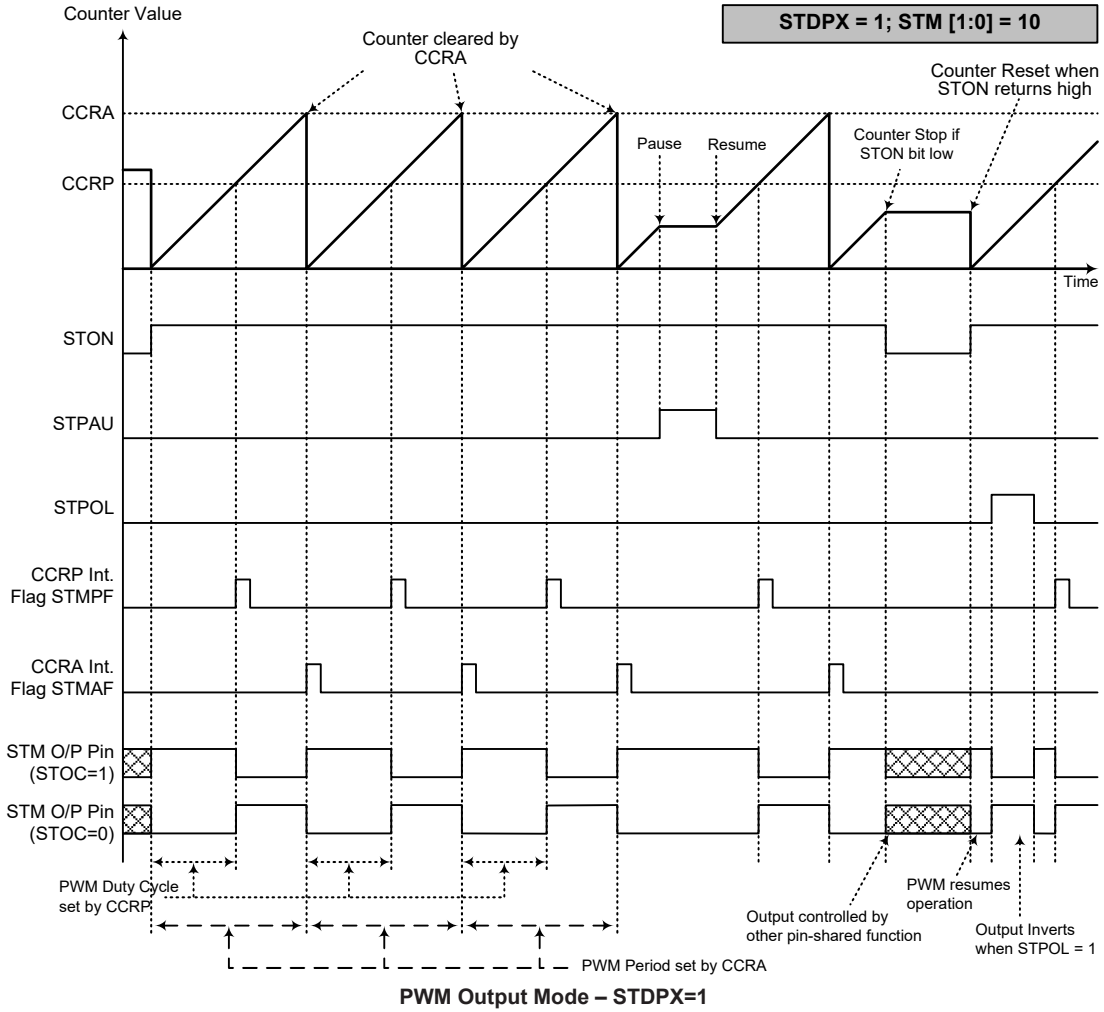

- Note: 1. Here STDPX=1 – Counter cleared by CCRA  
 2. A counter clear sets the PWM Period  
 3. The internal PWM function continues even when STIO[1:0]=00 or 01  
 4. The STCCLR bit has no influence on PWM operation

### Single Pulse Output Mode

To select this mode, bits STM1 and STM0 in the STMC1 register should be set to 10 respectively and also the STIO1 and STIO0 bits should be set to 11 respectively. The Single Pulse Output Mode, as the name suggests, will generate a single shot pulse on the STM output pin.

The trigger for the pulse output leading edge is a low to high transition of the STON bit, which can be implemented using the application program. However in the Single Pulse Output Mode, the STON bit can also be made to automatically change from low to high using the external STCK pin, which will in turn initiate the Single Pulse output. When the STON bit transitions to a high level, the counter will start running and the pulse leading edge will be generated. The STON bit should remain high when the pulse is in its active state. The generated pulse trailing edge will be generated when the STON bit is cleared to zero, which can be implemented using the application program or when a compare match occurs from Comparator A.

However a compare match from Comparator A will also automatically clear the STON bit and thus generate the Single Pulse output trailing edge. In this way the CCRA value can be used to control the pulse width. A compare match from Comparator A will also generate a STM interrupt. The counter can only be reset back to zero when the STON bit changes from low to high when the counter restarts. In the Single Pulse Output Mode CCRP is not used. The STCCLR and STDPX bits are not used in this Mode.

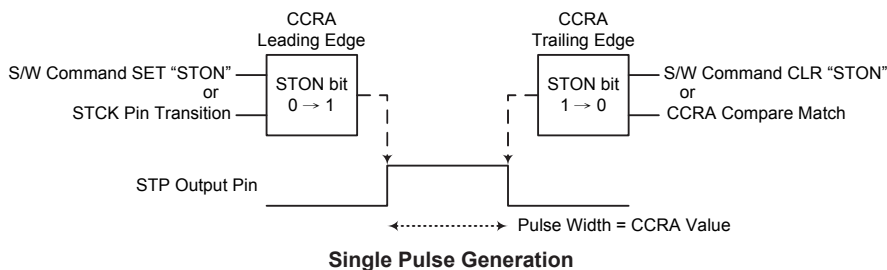

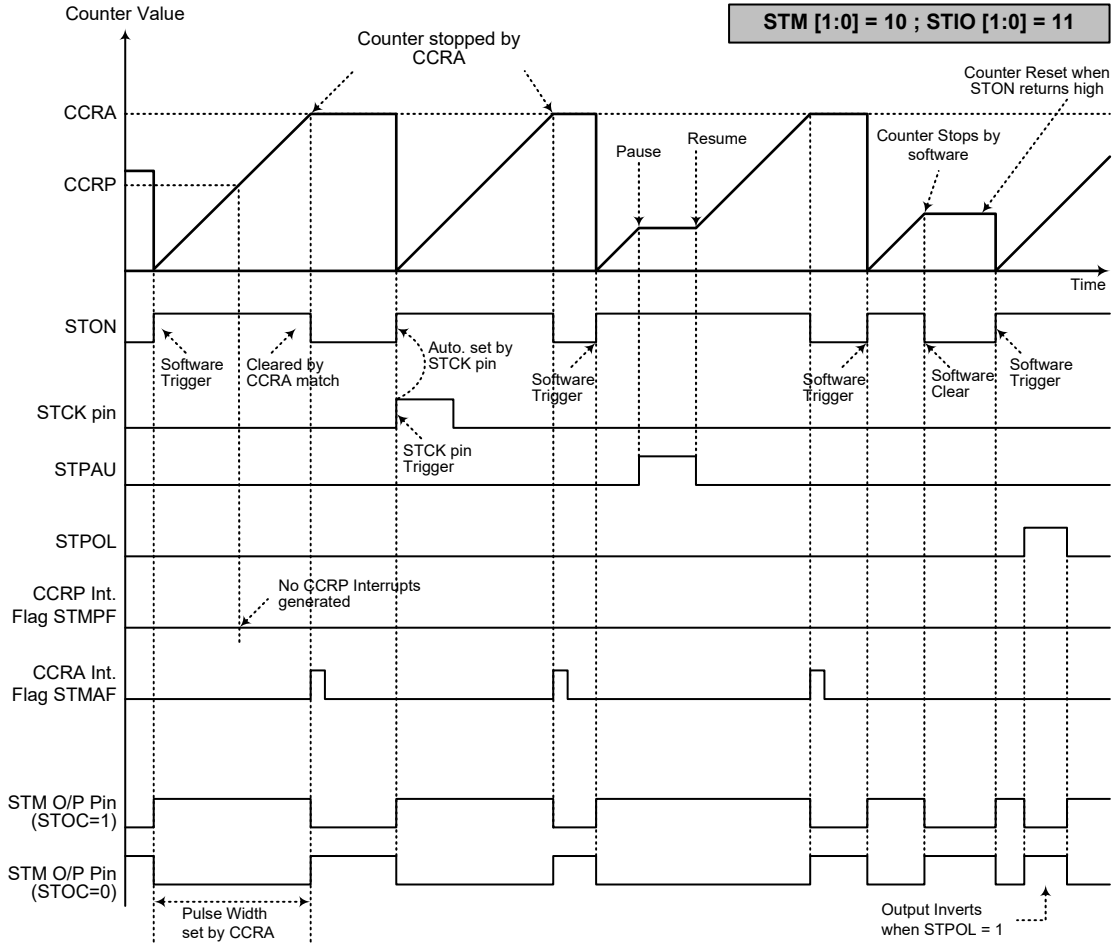

**Single Pulse Output Mode**

- Note:
1. Counter stopped by CCRA
  2. CCRP is not used
  3. The pulse triggered by the STCK pin or by setting the STON bit high
  4. A STCK pin active edge will automatically set the STON bit high
  5. In the Single Pulse Output Mode, STIO[1:0] must be set to "11" and cannot be changed

### **Capture Input Mode**

To select this mode bits STM1 and STM0 in the STMC1 register should be set to 01 respectively. This mode enables external signals to capture and store the present value of the internal counter and can therefore be used for applications such as pulse width measurements. The external signal is supplied on the STPI pin, whose active edge can be a rising edge, a falling edge or both rising and falling edges; the active edge transition type is selected using the STIO1 and STIO0 bits in the STMC1 register. The counter is started when the STON bit changes from low to high which is initiated using the application program.

When the required edge transition appears on the STPI pin the present value in the counter will be latched into the CCRA registers and a STM interrupt generated. Irrespective of what events occur on the STPI pin the counter will continue to free run until the STON bit changes from high to low. When a CCRP compare match occurs the counter will reset back to zero; in this way the CCRP value can be used to control the maximum counter value. When a CCRP compare match occurs from Comparator P, a STM interrupt will also be generated. Counting the number of overflow interrupt signals from the CCRP can be a useful method in measuring long pulse widths. The STIO1 and STIO0 bits can select the active trigger edge on the STPI pin to be a rising edge, falling edge or both edge types. If the STIO1 and STIO0 bits are both set high, then no capture operation will take place irrespective of what happens on the STPI pin, however it must be noted that the counter will continue to run. The STCCLR and STDPX bits are not used in this Mode.

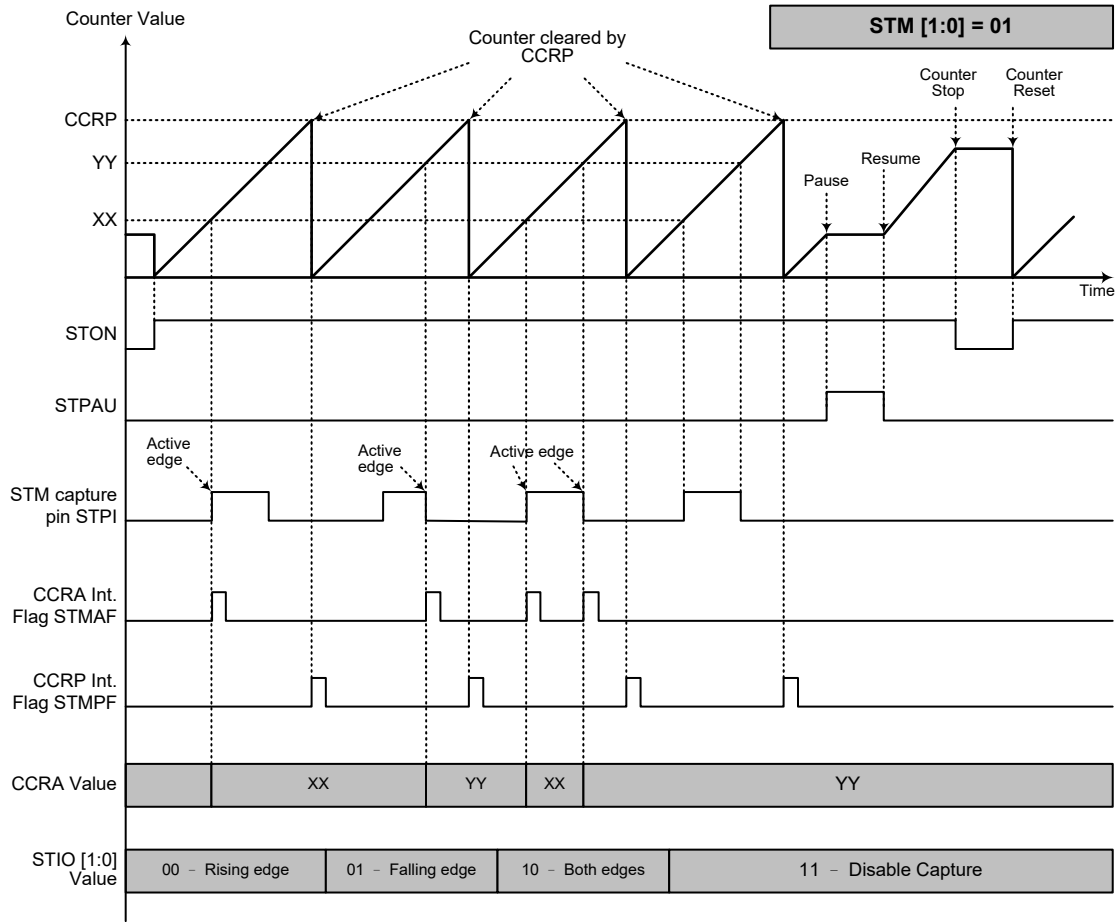

**Capture Input Mode**

- Note: 1. STM[1:0]=01 and active edge set by the STIO[1:0] bits  
 2. A STM Capture input pin active edge transfers the counter value to CCRA  
 3. STCCLR bit not used  
 4. No output function – STOC and STPOL bits are not used  
 5. CCRP determines the counter value and the counter has a maximum count value when CCRP is equal to zero.

## Analog to Digital Converter

The need to interface to real world analog signals is a common requirement for many electronic systems. However, to properly process these signals by a microcontroller, they must first be converted into digital signals by A/D converters. By integrating the A/D conversion electronic circuitry into the microcontroller, the need for external components is reduced significantly with the corresponding follow-on benefits of lower costs and reduced component space requirements.

### A/D Converter Overview

This device contains a multi-channel analog to digital converter which can directly interface to external analog signals, such as that from sensors or other control signals, or internal analog signals, such as the OPA2 output voltage,  $20 \times A2P$ , and convert these signals directly into a 12-bit digital value. The external or internal analog signal to be converted is determined by the SAINS2~SAINS0 bits together with the SACS3~SACS0 bits. More detailed information about the A/D input signal is described in the “A/D Converter Control Registers” and “A/D Converter Input Signals” sections respectively.

External Input Channels	Internal Input Signals	A/D Input Select Bits
AN0~AN9	$20 \times A2P$	SAINS2~SAINS0, SACS3~SACS0

The accompanying block diagram shows the overall internal structure of the A/D converter, together with its associated registers.

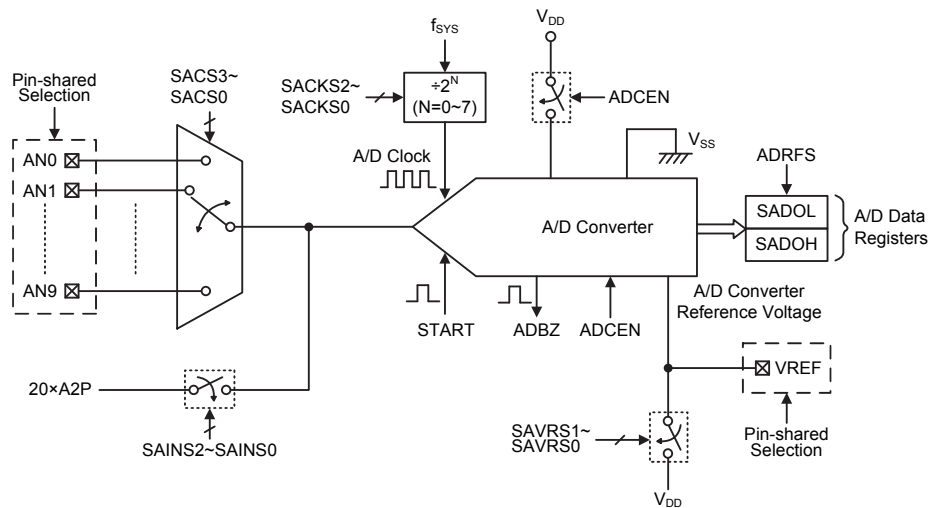

**A/D Converter Structure**

Note:  $20 \times A2P$  is 20 times OPA2 positive input voltage signal. More details can be obtained in the Battery Charge Module section.

### A/D Converter Register Description

Overall operation of the A/D converter is controlled using a series of registers. A read only register pair exists to store the A/D converter data 12-bit value. The remaining two registers are control registers which setup the operating and control function of the A/D converter.

Register Name	Bit							
	7	6	5	4	3	2	1	0
SADOL (ADRF5=0)	D3	D2	D1	D0	—	—	—	—
SADOL (ADRF5=1)	D7	D6	D5	D4	D3	D2	D1	D0
SADOH (ADRF5=0)	D11	D10	D9	D8	D7	D6	D5	D4
SADOH (ADRF5=1)	—	—	—	—	D11	D10	D9	D8
SADC0	START	ADBZ	ADCEN	ADRF5	SACS3	SACS2	SACS1	SACS0
SADC1	SAINS2	SAINS1	SAINS0	SAVRS1	SAVRS0	SACKS2	SACKS1	SACKS0

**A/D Converter Register List**

### A/D Converter Data Registers – SADOL, SADOH

As the device contains an internal 12-bit A/D converter, it requires two data registers to store the converted value. These are a high byte register, known as SADOH, and a low byte register, known as SADOL. After the conversion process takes place, these registers can be directly read by the microcontroller to obtain the digitised conversion value. As only 12 bits of the 16-bit register space is utilised, the format in which the data is stored is controlled by the ADRF5 bit in the SADC0 register as shown in the accompanying table. D0~D11 are the A/D conversion result data bits. Any unused bits will be read as zero. Note that the A/D converter data register contents will be unchanged if the A/D converter is disabled.

ADRF5	SADOH								SADOL							
	7	6	5	4	3	2	1	0	7	6	5	4	3	2	1	0
0	D11	D10	D9	D8	D7	D6	D5	D4	D3	D2	D1	D0	0	0	0	0
1	0	0	0	0	D11	D10	D9	D8	D7	D6	D5	D4	D3	D2	D1	D0

**A/D Data Registers**

### A/D Converter Control Registers – SADC0, SADC1

To control the function and operation of the A/D converter, several control registers known as SADC0 and SADC1 are provided. These 8-bit registers define functions such as the selection of which analog channel is connected to the internal A/D converter, the digitised data format, the A/D clock source as well as controlling the start function and monitoring the A/D converter busy status. As the device contains only one actual analog to digital converter hardware circuit, each of the external or internal analog signal inputs must be routed to the converter. The SACS3~SACS0 bits in the SADC0 register are used to determine which external channel input is selected to be converted. The SAINS2~SAINS0 bits in the SADC1 register are used to determine that the analog signal to be converted comes from the internal analog signal or external analog channel input.

The pin-shared function selection bits determine which pins on I/O Ports are used as analog inputs for the A/D converter input and which pins are not to be used as the A/D converter input. When the pin is selected to be an A/D input, its original function, whether it is an I/O or other pin-shared function will be removed. In addition, any internal pull-high resistors connected to these pins will be automatically removed if the pin is selected to be an A/D input.

• **SADC0 Register**

Bit	7	6	5	4	3	2	1	0
Name	START	ADBZ	ADCEN	ADRF5	SACS3	SACS2	SACS1	SACS0
R/W	R/W	R	R/W	R/W	R/W	R/W	R/W	R/W
POR	0	0	0	0	0	0	0	0

- Bit 7**     **START:** Start the A/D conversion  
0→1→0: Start  
This bit is used to initiate an A/D conversion process. The bit is normally low but if set high and then cleared low again, the A/D converter will initiate a conversion process.
- Bit 6**     **ADBZ:** A/D converter busy flag  
0: No A/D conversion is in progress  
1: A/D conversion is in progress  
This read only flag is used to indicate whether the A/D conversion is in progress or not. When the START bit is set from low to high and then to low again, the ADBZ flag will be set to 1 to indicate that the A/D conversion is initiated. The ADBZ flag will be cleared to 0 after the A/D conversion is complete.
- Bit 5**     **ADCEN:** A/D converter function enable control  
0: Disable  
1: Enable  
This bit controls the A/D internal function. This bit should be set to one to enable the A/D converter. If the bit is set low, then the A/D converter will be switched off reducing the device power consumption. When the A/D converter function is disabled, the contents of the A/D data register pair known as SADOH and SADOL will be unchanged.
- Bit 4**     **ADRF5:** A/D converter data format selection  
0: A/D converter data format → SADOH=D[11:4]; SADOL=D[3:0]  
1: A/D converter data format → SADOH=D[11:8]; SADOL=D[7:0]  
This bit controls the format of the 12-bit converted A/D value in the two A/D data registers. Details are provided in the A/D data register section.
- Bit 3~0**   **SACS3~SACS0:** A/D converter external analog input channel selection  
0000: AN0  
0001: AN1  
0010: AN2  
0011: AN3  
0100: AN4  
0101: AN5  
0110: AN6  
0111: AN7  
1000: AN8  
1001: AN9  
1010~1111: Undefined, input floating

• **SADC1 Register**

Bit	7	6	5	4	3	2	1	0
Name	SAINS2	SAINS1	SAINS0	SAVRS1	SAVRS0	SACKS2	SACKS1	SACKS0
R/W	R/W	R/W	R/W	R/W	R/W	R/W	R/W	R/W
POR	0	0	0	0	0	0	0	0

- Bit 7~5**   **SAINS2~SAINS0:** A/D converter input signal selection  
000: External source – External analog channel input, ANn  
001: Internal source – Internal OPA2 output voltage, 20×A2P  
010~100: Unused, connected to ground  
101~111: External source – External analog channel input, ANn

Care must be taken if the SAINS2~SAINS0 bits are set to “001” to select the internal analog signal to be converted. When the internal analog signal is selected to be converted, the external input pin must never be selected as the A/D input signal by properly setting the SACS3~SACS0 bits with a value from 1010 to 1111. Otherwise, the external channel input will be connected together with the internal analog signal. This will result in unpredictable situations such as an irreversible damage.

- Bit 4~3 **SAVRS1~SAVRS0**: A/D converter reference voltage selection
- 00: External VREF pin
  - 01: Internal A/D converter power,  $V_{DD}$
  - 1x: External VREF pin

These bits are used to select the A/D converter reference voltage source. Care must be taken if the SAVRS1~SAVRS0 bits are set to “01” to select the internal A/D converter power as the reference voltage source. When the internal A/D converter power is selected as the reference voltage, the VREF pin cannot be configured as the reference voltage input by properly configuring the corresponding pin-shared function control bits. Otherwise, the external input voltage on VREF pin will be connected to the internal A/D converter power. This will result in unpredictable situations.

- Bit 2~0 **SACKS2~SACKS0**: A/D converter clock rate selection bit
- 000:  $f_{SYS}$
  - 001:  $f_{SYS}/2$
  - 010:  $f_{SYS}/4$
  - 011:  $f_{SYS}/8$
  - 100:  $f_{SYS}/16$
  - 101:  $f_{SYS}/32$
  - 110:  $f_{SYS}/64$
  - 111:  $f_{SYS}/128$

### A/D Converter Reference Voltage

The reference voltage supply to the A/D converter can be supplied from the positive power supply,  $V_{DD}$ , or from an external reference source supplied on pin VREF. The desired selection is made using the SAVRS1 and SAVRS0 bits. When the SAVRS bit field is set to “01”, the A/D converter reference voltage will come from the  $V_{DD}$ . Otherwise, if the SAVRS bit field is set to any other value except “01”, the A/D converter reference voltage will come from the VREF pin. As the VREF pin is pin-shared with other functions, when the VREF pin is selected as the reference voltage supply pin, the VREF pin-shared function control bit should be properly configured to disable other pin functions. However, if the internal A/D converter power is selected as the reference voltage, the VREF pin must not be configured as the reference voltage input function to avoid the internal connection between the VREF pin and A/D converter power  $V_{DD}$ . The analog input values must not be allowed to exceed the value of the selected A/D reference voltage.

### A/D Converter Input Signal

All the external A/D analog channel input pins are pin-shared with the I/O pins as well as other functions. The corresponding control bits for each A/D external input pin in the PxS0 and PxS1 registers determine whether the input pins are setup as A/D converter analog inputs or whether they have other functions. If the pin is setup to be as an A/D analog channel input, the original pin functions will be disabled. In this way, pins can be changed under program control to change their function between A/D inputs and other functions. All pull high resistors, which are setup through register programming, will be automatically disconnected if the pins are setup as A/D inputs. Note that it is not necessary to first setup the A/D pin as an input in the port control register to enable the A/D input as when the pin-shared function control bits enable an A/D input, the status of the port control register will be overridden.

There is an internal analog signal derived from 20×A2P, which can be connected to the A/D converter as the analog input signal by configuring the SAINS2~SAINS0 bits. If the external channel input is selected to be converted, the SAINS2~SAINS0 bits should be set to “000” or “101~111” and the SACS3~SACS0 bits can determine which external channel is selected. If the internal analog signal is selected to be converted, the SACS3~SACS0 bits must be configured with a value from 1010 to 1111 to switch off the external analog channel input. Otherwise, the internal analog signal will be connected together with the external channel input. This will result in unpredictable situations.

SAINS[2:0]	SACS[3:0]	Input Signals	Description
000, 101~111	0000~1001 1010~1111	AN0~AN9 —	External pin analog input Floating, no external channel is selected
001	1010~1111	20×A2P	20 times OPA2 positive input voltage signal
010~100	1010~1111	—	Unused, connected to ground

**A/D Converter Input Signal Selection**

### A/D Converter Operation

The START bit in the SADC0 register is used to start the A/D conversion. When the microcontroller sets this bit from low to high and then low again, an analog to digital conversion cycle will be initiated.

The ADBZ bit in the SADC0 register is used to indicate whether the analog to digital conversion process is in progress or not. This bit will be automatically set to 1 by the microcontroller after an A/D conversion is successfully initiated. When the A/D conversion is complete, the ADBZ will be cleared to 0. In addition, the corresponding A/D interrupt request flag will be set in the interrupt control register, and if the interrupts are enabled, an appropriate internal interrupt signal will be generated. This A/D internal interrupt signal will direct the program flow to the associated A/D internal interrupt address for processing. If the A/D internal interrupt is disabled, the microcontroller can poll the ADBZ bit in the SADC0 register to check whether it has been cleared as an alternative method of detecting the end of an A/D conversion cycle.

The clock source for the A/D converter, which originates from the system clock  $f_{SYS}$ , can be chosen to be either  $f_{SYS}$  or a subdivided version of  $f_{SYS}$ . The division ratio value is determined by the SACKS2~SACKS0 bits in the SADC1 register. Although the A/D clock source is determined by the system clock  $f_{SYS}$  and by bits SACKS2~SACKS0, there are some limitations on the maximum A/D clock source speed that can be selected. As the recommended range of permissible A/D clock period,  $t_{ADCK}$ , is from 0.5 $\mu$ s to 10 $\mu$ s, care must be taken for system clock frequencies. For example, if the system clock operates at a frequency of 8MHz, the SACKS2~SACKS0 bits should not be set to 000, 001 or 111. Doing so will give A/D clock periods that are less than the minimum A/D clock period or greater than the maximum A/D clock period which may result in inaccurate A/D conversion values. Refer to the following table for examples, where values marked with an asterisk \* show where, depending upon the device, special care must be taken, as the values may be exceeding the specified A/D Clock Period range.

$f_{SYS}$	A/D Clock Period ( $t_{ADCK}$ )							
	SACKS[2:0] = 000 ( $f_{SYS}$ )	SACKS[2:0] = 001 ( $f_{SYS}/2$ )	SACKS[2:0] = 010 ( $f_{SYS}/4$ )	SACKS[2:0] = 011 ( $f_{SYS}/8$ )	SACKS[2:0] = 100 ( $f_{SYS}/16$ )	SACKS[2:0] = 101 ( $f_{SYS}/32$ )	SACKS[2:0] = 110 ( $f_{SYS}/64$ )	SACKS[2:0] = 111 ( $f_{SYS}/128$ )
1MHz	1 $\mu$ s	2 $\mu$ s	4 $\mu$ s	8 $\mu$ s	16 $\mu$ s *	32 $\mu$ s *	64 $\mu$ s *	128 $\mu$ s *
2MHz	500ns	1 $\mu$ s	2 $\mu$ s	4 $\mu$ s	8 $\mu$ s	16 $\mu$ s *	32 $\mu$ s *	64 $\mu$ s *
4MHz	250ns *	500ns	1 $\mu$ s	2 $\mu$ s	4 $\mu$ s	8 $\mu$ s	16 $\mu$ s *	32 $\mu$ s *
8MHz	125ns *	250ns *	500ns	1 $\mu$ s	2 $\mu$ s	4 $\mu$ s	8 $\mu$ s	16 $\mu$ s *

**A/D Clock Period Examples**

Controlling the power on/off function of the A/D converter circuitry is implemented using the ADCEN bit in the SADC0 register. This bit must be set high to power on the A/D converter. When the ADCEN bit is set high to power on the A/D converter internal circuitry a certain delay, as indicated in the timing diagram, must be allowed before an A/D conversion is initiated. Even if no pins are selected for use as A/D inputs, if the ADCEN bit is high, then some power will still be consumed. In power conscious applications it is therefore recommended that the ADCEN is set low to reduce power consumption when the A/D converter function is not being used.

### Conversion Rate and Timing Diagram

A complete A/D conversion contains two parts, data sampling and data conversion. The data sampling which is defined as  $t_{ADS}$  takes 4 A/D clock cycles and the data conversion takes 12 A/D clock cycles. Therefore a total of 16 A/D clock cycles for an external input A/D conversion which is defined as  $t_{ADC}$  are necessary.

$$\text{Maximum single A/D conversion rate} = \text{A/D clock period} / 16$$

The accompanying diagram shows graphically the various stages involved in an analog to digital conversion process and its associated timing. After an A/D conversion process has been initiated by the application program, the microcontroller internal hardware will begin to carry out the conversion, during which time the program can continue with other functions. The time taken for the A/D conversion is 16  $t_{ADCK}$  clock cycles where  $t_{ADCK}$  is equal to the A/D clock period.

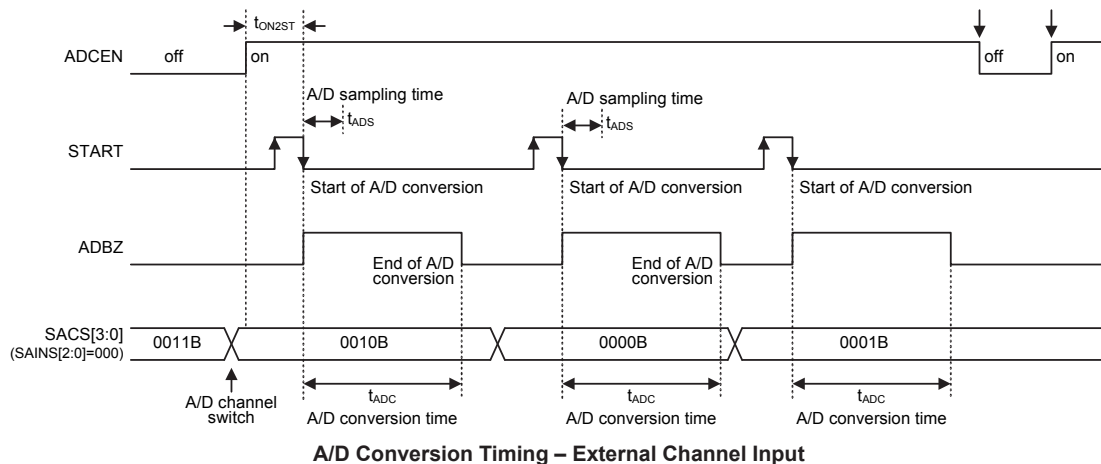

### Summary of A/D Conversion Steps

The following summarises the individual steps that should be executed in order to implement an A/D conversion process.

- Step 1  
Select the required A/D conversion clock by correctly programming bits SACKS2~SACKS0 in the SADC1 register.
- Step 2  
Enable the A/D converter by setting the ADCEN bit in the SADC0 register to 1.
- Step 3  
Select which signal is to be connected to the internal A/D converter by correctly configuring the SAINS2~SAINS0 bits.  
Select the external channel input to be converted, go to Step 4.  
Select the internal analog signal to be converted, go to Step 5.

- Step 4  
If the A/D converter input signal comes from the external channel input selecting by configuring the SAINS bit field, the corresponding pins should be configured as A/D converter input function by configuring the relevant pin-shared function control bits. The desired analog channel then should be selected by configuring the SACS bit field. After this step, go to Step 6.
- Step 5  
Before the A/D converter input signal is selected to come from the internal analog signal by configuring the SAINS bit field, the corresponding external input pin must be switched to a non-existent channel input by setting the SACS3~SACS0 bits with a value from 1010 to 1111. The desired internal analog signal then can be selected by configuring the SAINS bit field. After this step, go to Step 6.
- Step 6  
Select the reference voltage source by configuring the SAVRS1~SAVRS0 bits in the SADC1 register.
- Step 7  
Select A/D converter output data format by setting the ADRFS bit in the SADC0 register.
- Step 8  
If A/D conversion interrupt is used, the interrupt control registers must be correctly configured to ensure the A/D interrupt function is active. The master interrupt control bit, EMI, and the A/D conversion interrupt control bit, ADE, must both be set high in advance.
- Step 9  
The A/D conversion procedure can now be initialized by setting the START bit from low to high and then low again.
- Step 10  
If A/D conversion is in progress, the ADBZ flag will be set high. After the A/D conversion process is complete, the ADBZ flag will go low and then the output data can be read from SADOH and SADOL registers.

Note: When checking for the end of the conversion process, if the method of polling the ADBZ bit in the SADC0 register is used, the interrupt enable step above can be omitted.

## Programming Considerations

During microcontroller operations where the A/D converter is not being used, the A/D internal circuitry can be switched off to reduce power consumption, by clearing bit ADCEN to 0 in the SADC0 register. When this happens, the internal A/D converter circuits will not consume power irrespective of what analog voltage is applied to their input lines. If the A/D converter input lines are used as normal I/O pins, then care must be taken as if the input voltage is not at a valid logic level, then this may lead to some increase in power consumption.

## A/D Conversion Function

As the device contains a 12-bit A/D converter, its full-scale converted digitised value is equal to FFFH. Since the full-scale analog input value is equal to the actual A/D converter reference voltage,  $V_{REF}$ , this gives a single bit analog input value of  $V_{REF}$  divided by 4096.

$$1 \text{ LSB} = V_{REF}/4096$$

The A/D Converter input voltage value can be calculated using the following equation:

$$\text{A/D input voltage} = \text{A/D output digital value} \times (V_{REF}/4096)$$

The diagram shows the ideal transfer function between the analog input value and the digitised output value for the A/D converter. Except for the digitised zero value, the subsequent digitised values will change at a point 0.5 LSB below where they would change without the offset, and the last full scale digitised value will change at a point 1.5 LSB below the  $V_{REF}$  level.

Note that here the  $V_{REF}$  voltage is the actual A/D converter reference voltage determined by the SAVRS field.

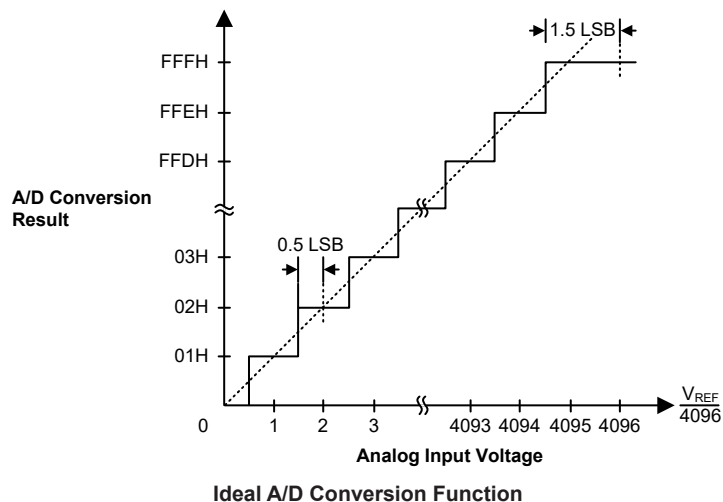

### A/D Conversion Programming Examples

The following two programming examples illustrate how to setup and implement an A/D conversion. In the first example, the method of polling the ADBZ bit in the SADC0 register is used to detect when the conversion cycle is complete, whereas in the second example, the A/D interrupt is used to determine when the conversion is complete.

#### Example: using an EOCB polling method to detect the end of conversion

```

clr ADE           ; disable A/D converter interrupt
mov a,03h        ; select fsys/8 as A/D clock and
mov SADC1,a      ; select external channel input and external reference input
mov a,0Ah        ; setup PBS0 to configure pin AN0 and pin VREF
mov PBS0,a
mov a,20h
mov SADC0,a      ; enable A/D and connect AN0 channel to A/D converter
:
start_conversion:
clr START        ; high pulse on start bit to initiate conversion
set START        ; reset A/D
clr START        ; start A/D
polling_EOC:
sz ADBZ          ; poll the SADC0 register ADBZ bit to detect end of A/D conversion
jmp polling_EOC  ; continue polling
mov a,SADOL      ; read low byte conversion result value
mov SADOL_buffer,a ; save result to user defined register
mov a,SADOH      ; read high byte conversion result value
mov SADOH_buffer,a ; save result to user defined register
:
:
jmp start_conversion ; start next A/D conversion
    
```

**Example: using the interrupt method to detect the end of conversion**

```
clr ADE          ; disable A/D converter interrupt
mov a,03h        ; select fsys/8 as A/D clock and
mov SADC1,a      ; select external channel input and external reference input
mov a,0Ah        ; setup PBS0 to configure pin AN0 and pin VREF
mov PBS0,a
mov a,20h
mov SADC0,a      ; enable A/D and connect AN0 channel to A/D converter
Start_conversion:
clr START        ; high pulse on START bit to initiate conversion
set START        ; reset A/D
clr START        ; start A/D
clr ADF          ; clear ADC interrupt request flag
set ADE          ; enable A/D converter interrupt
set EMI          ; enable global interrupt
:
:
; ADC interrupt service routine
ADC_ISR:
mov acc_stack,a  ; save ACC to user defined memory
mov a,STATUS
mov status_stack,a ; save STATUS to user defined memory
:
:
mov a,SADOL      ; read low byte conversion result value
mov SADOL_buffer,a ; save result to user defined register
mov a,SADOH      ; read high byte conversion result value
mov SADOH_buffer,a ; save result to user defined register
:
:
EXIT_INT_ISR:
mov a,status_stack
mov STATUS,a    ; restore STATUS from user defined memory
mov a,acc_stack ; restore ACC from user defined memory
reti
```

## Battery Charge Module

The device contains a battery charge module which consists of three operational amplifiers, a 14-bit and a 12-bit D/A converters. The OPA0 together with DAC0 and OPA1 together with DAC1 are used for battery charge constant current (CC) and constant voltage (CV) control respectively. The OPA2 is used for battery charge current amplification.

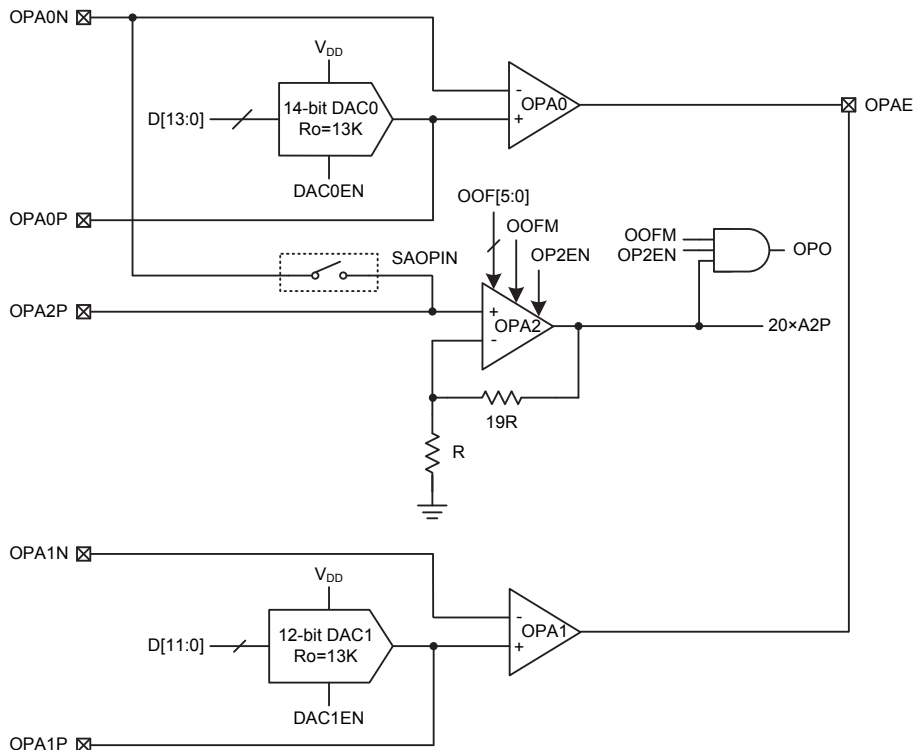

**Battery Charge Module Structure**

- Note:
1. The OPA0 and OPA1 are always enabled, while the OPA2 is controlled by the OP2EN bit in DAOPC register.
  2. The OPA0 and OPA1 are open drain outputs.
  3. The OPA0 and OPA1 do not need to calibrate the input offset.
  4. The OPA2 needs to calibrate the input offset.
  5. When the DAC0 or DAC1 is disabled, the output will be in a floating state.

## Battery Charge Module Registers

Overall operation of the battery charge module is controlled using a series of registers and the corresponding register definitions are described in the accompanying sections.

Register Name	Bit							
	7	6	5	4	3	2	1	0
DA0L	D7	D6	D5	D4	D3	D2	D1	D0
DA0H	—	—	D13	D12	D11	D10	D9	D8
DA1L	D7	D6	D5	D4	D3	D2	D1	D0
DA1H	—	—	—	—	D11	D10	D9	D8
DAOPC	DAC1EN	DAC0EN	OP2EN	—	—	—	SAOPIN	OPO
OPVOS	OOFM	—	OOF5	OOF4	OOF3	OOF2	OOF1	OOF0

**Battery Charge Module Register List**

## Digital to Analog Converter

The battery charge module contains a 14-bit and 12-bit R2R D/A converters, namely DAC0 and DAC1. Their reference input voltage comes from  $V_{DD}$ , and can be power down to save power.

The DAC0 and DAC1 are enabled or disabled by the DAOPC register. They are used to set a reference charging current and voltage using the DA0H/DA0L and DA1H/DA1L registers respectively.

### • DA0L Register

Bit	7	6	5	4	3	2	1	0
Name	D7	D6	D5	D4	D3	D2	D1	D0
R/W	R/W	R/W	R/W	R/W	R/W	R/W	R/W	R/W
POR	0	1	0	0	0	0	0	0

Bit 7~0 **D7~D0**: D/A converter 0 output control code low byte

Writing this register will only write the data to a shadow buffer and writing the DA0H register will simultaneously copy the shadow buffer data to the DA0L register.

### • DA0H Register

Bit	7	6	5	4	3	2	1	0
Name	—	—	D13	D12	D11	D10	D9	D8
R/W	—	—	R/W	R/W	R/W	R/W	R/W	R/W
POR	—	—	0	0	0	0	0	0

Bit 7~6 Unimplemented, read as “0”

Bit 5~0 **D13~D8**: D/A converter 0 output control code high byte

The D/A converter 0 output voltage is calculated using the following equation:

$$DAC0OUT = (V_{DD}/2^{14}) \times D[13:0], \text{ where } V_{DD} \text{ is D/A converter 0 reference input voltage.}$$

### • DA1L Register

Bit	7	6	5	4	3	2	1	0
Name	D7	D6	D5	D4	D3	D2	D1	D0
R/W	R/W	R/W	R/W	R/W	R/W	R/W	R/W	R/W
POR	0	0	0	0	0	0	0	0

Bit 7~0 **D7~D0**: D/A converter 1 output control code low byte

Writing this register will only write the data to a shadow buffer and writing the DA1H register will simultaneously copy the shadow buffer data to the DA1L register.

### • DA1H Register

Bit	7	6	5	4	3	2	1	0
Name	—	—	—	—	D11	D10	D9	D8
R/W	—	—	—	—	R/W	R/W	R/W	R/W
POR	—	—	—	—	1	0	0	0

Bit 7~4 Unimplemented, read as “0”

Bit 3~0 **D11~D8**: D/A converter 1 output control code high byte

The D/A converter 1 output voltage is calculated using the following equation:

$$DAC1OUT = (V_{DD}/2^{12}) \times D[11:0], \text{ where } V_{DD} \text{ is D/A converter 1 reference input voltage.}$$

• **DAOPC Register**

Bit	7	6	5	4	3	2	1	0
Name	DAC1EN	DAC0EN	OP2EN	—	—	—	SAOPIN	OPO
R/W	R/W	R/W	R/W	—	—	—	R/W	R
POR	1	1	0	—	—	—	0	0

- Bit 7      **DAC1EN**: D/A converter 1 enable control  
0: Disable, D/A converter 1 output floating  
1: Enable
- Bit 6      **DAC0EN**: D/A converter 0 enable control  
0: Disable, D/A converter 0 output floating  
1: Enable
- Bit 5      **OP2EN**: OPA2 enable control  
0: Disable  
1: Enable
- Bit 4~2    Unimplemented, read as “0”
- Bit 1      **SAOPIN**: Switch OPA0N signal to OPA2P  
0: Disable  
1: Enable
- Bit 0      **OPO**: OPA2 digital logic output  
The OPO is cleared to 0 when the OPA2 is disabled.

**Operational Amplifiers**

The battery charge module contains three operational amplifiers, namely OPA0, OPA1 and OPA2. The OPA0 and OPA1 are always enabled and do not need to calibrate the input offset. The OPA2 related functions are controlled using the DAOPC and OPVOS registers.

The DAOPC register is used for control OPA2 enable/disable and output status monitoring. The OPVOS register is used for OPA2 input offset calibration voltage selection and control.

• **OPVOS Register**

Bit	7	6	5	4	3	2	1	0
Name	OOFM	—	OOF5	OOF4	OOF3	OOF2	OOF1	OOF0
R/W	R/W	—	R/W	R/W	R/W	R/W	R/W	R/W
POR	0	—	1	0	0	0	0	0

- Bit 7      **OOFM**: OPA2 normal operation or input offset voltage cancellation mode selection bit  
0: Normal operation  
1: Offset calibration mode  
The input reference voltage comes from OPA2 positive input pin at offset voltage cancellation mode.
- Bit 6      Unimplemented, read as “0”
- Bit 5~0    **OOF5~OOF0**: OPA2 input offset voltage calibration control bits

**Operational Amplifier 2 Operation**

The OPA2 provides input offset calibration function. The calibrated data is stored in the OOF bit field. The OOFM bit is used to control cancellation mode selection. The input reference voltage comes from the OPA2P pin in calibration mode. The OPA2P pin is the OPA2 positive input and the 20×A2P signal is the OPA2 analog output voltage. The OPA2 digital output flag is OPO, which is used for OPA2 calibration mode. Finally, the OP2EN bit is used to enable or disable the OPA2 function.

### Offset Calibration Procedure

As the OPA2 input pin is pin-shared with other functions, it should be configured as the operational amplifier input first by the corresponding pin-shared function selection register.

Step1: Set OOFM=1, the OPA2 is now under offset calibration mode. To make sure the input offset voltage  $V_{OS}$  as minimise as possible after calibration, the input reference voltage in calibration mode should be the same as input DC operating voltage in normal mode operation.

Step2: Set OOF[5:0]=000000 then read OPO flag.

Step3: Let OOF[5:0]=OOF[5:0]+1 then read OPO flag, if the OPO flag state is changed, record the data as  $V_{OS1}$ .

Step4: Set OOF[5:0]=111111 then read OPO flag.

Step5: Let OOF[5:0]=OOF[5:0]-1 then read OPO flag, if the OPO flag state is changed; record the data as  $V_{OS2}$ .

Step6: restore  $V_{OS}=(V_{OS1}+V_{OS2})/2$  to OOF[5:0] bits, the calibration is finished.

If  $(V_{OS1}+V_{OS2})/2$  is not integral, discard the decimal.

Residue  $V_{OS}=V_{OUT}-V_{IN}$ .

## Universal Serial Interface Module – USIM

The device contains a Universal Serial Interface Module, which includes the four-line SPI interface, the two-line I<sup>2</sup>C interface and the two-line UART interface types, to allow an easy method of communication with external peripheral hardware. Having relatively simple communication protocols, these serial interface types allow the microcontroller to interface to external SPI, I<sup>2</sup>C or UART based hardware such as sensors, Flash or EEPROM memory, etc. The USIM interface pins are pin-shared with other I/O pins therefore the USIM interface functional pins must first be selected using the corresponding pin-shared function selection bits. As all the interface types share the same pins and registers, the choice of whether the UART, SPI or I<sup>2</sup>C type is used is made using the UART mode selection bit, named UMD, and the SPI/I<sup>2</sup>C operating mode control bits, named SIM2~SIM0, in the SIMC0 register. These pull-high resistors of the USIM pin-shared I/O are selected using pull-high control registers when the USIM function is enabled and the corresponding pins are used as USIM input pins.

### SPI Interface

The SPI interface is often used to communicate with external peripheral devices such as sensors, Flash or EEPROM memory devices etc. Originally developed by Motorola, the four line SPI interface is a synchronous serial data interface that has a relatively simple communication protocol simplifying the programming requirements when communicating with external hardware devices.

The communication is full duplex and operates as a slave/master type, where the device can be either master or slave. Although the SPI interface specification can control multiple slave devices from a single master, but the device provides only one  $\overline{SCS}$  pin. If the master needs to control multiple slave devices from a single master, the master can use I/O pin to select the slave devices.

### SPI Interface Operation

The SPI interface is a full duplex synchronous serial data link. It is a four line interface with pin names SDI, SDO, SCK and  $\overline{SCS}$ . Pins SDI and SDO are the Serial Data Input and Serial Data Output lines, the SCK pin is the Serial Clock line and  $\overline{SCS}$  is the Slave Select line. As the SPI interface pins are pin-shared with normal I/O pins and with the I<sup>2</sup>C/UART function pins, the SPI interface pins must first be selected by configuring the pin-shared function selection bits and setting the correct bits in the SIMC0 and SIMC2 registers. Communication between devices connected to the SPI interface is carried out in a slave/master mode with all data transfer initiations being implemented by the master. The Master also controls the clock signal. As the device only contains a single  $\overline{SCS}$  pin only one slave device can be utilized. The  $\overline{SCS}$  pin is controlled by software, set

CSEN bit to 1 to enable  $\overline{SCS}$  pin function, set CSEN bit to 0 the  $\overline{SCS}$  pin will be floating state.

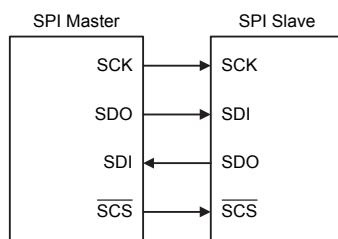

SPI Master/Slave Connection

The SPI function in the device offers the following features:

- Full duplex synchronous data transfer
- Both Master and Slave modes
- LSB first or MSB first data transmission modes
- Transmission complete flag
- Rising or falling active clock edge

The status of the SPI interface pins is determined by a number of factors such as whether the device is in the master or slave mode and upon the condition of certain control bits such as CSEN and SIMEN.

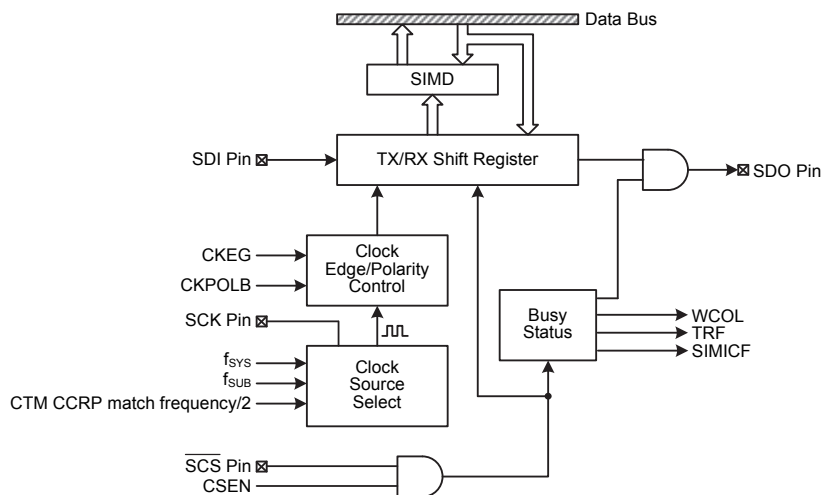

SPI Block Diagram

### SPI Registers

There are three internal registers which control the overall operation of the SPI interface. These are the SIMD data register and two control registers, SIMC0 and SIMC2. Note that the SIMC2 and SIMD registers and their POR values are only available when the SPI mode is selected by properly configuring the UMD and SIM2~SIM0 bits in the SIMC0 register.

Register Name	Bit							
	7	6	5	4	3	2	1	0
SIMC0	SIM2	SIM1	SIM0	UMD	SIMDEB1	SIMDEB0	SIMEN	SIMICF
SIMC2	D7	D6	CKPOLB	CKEG	MLS	CSEN	WCOL	TRF
SIMD	D7	D6	D5	D4	D3	D2	D1	D0

SPI Register List

### SPI Data Register

The SIMD register is used to store the data being transmitted and received. The same register is used by both the SPI and I<sup>2</sup>C functions. Before the device writes data to the SPI bus, the actual data to be transmitted must be placed in the SIMD register. After the data is received from the SPI bus, the device can read it from the SIMD register. Any transmission or reception of data from the SPI bus must be made via the SIMD register.

#### • SIMD Register

Bit	7	6	5	4	3	2	1	0
Name	D7	D6	D5	D4	D3	D2	D1	D0
R/W	R/W	R/W	R/W	R/W	R/W	R/W	R/W	R/W
POR	x	x	x	x	x	x	x	x

"x": unknown

Bit 7~0      **D7~D0**: USIM SPI/I<sup>2</sup>C data register bit 7 ~ bit 0

### SPI Control Registers

There are also two control registers for the SPI interface, SIMC0 and SIMC2. The SIMC0 register is used to control the enable/disable function and to set the data transmission clock frequency. The SIMC2 register is used for other control functions such as LSB/MSB selection, write collision flag etc.

#### • SIMC0 Register

Bit	7	6	5	4	3	2	1	0
Name	SIM2	SIM1	SIM0	UMD	SIMDEB1	SIMDEB0	SIMEN	SIMICF
R/W	R/W	R/W	R/W	R/W	R/W	R/W	R/W	R/W
POR	1	1	1	0	0	0	0	0

Bit 7~5      **SIM2~SIM0**: USIM SPI/I<sup>2</sup>C Operating Mode Control

- 000: SPI master mode; SPI clock is  $f_{SYS}/4$
- 001: SPI master mode; SPI clock is  $f_{SYS}/16$
- 010: SPI master mode; SPI clock is  $f_{SYS}/64$
- 011: SPI master mode; SPI clock is  $f_{SUB}$
- 100: SPI master mode; SPI clock is CTM CCRP match frequency/2
- 101: SPI slave mode
- 110: I<sup>2</sup>C slave mode
- 111: Unused mode

When the UMD bit is cleared to zero, these bits setup the SPI or I<sup>2</sup>C operating mode of the USIM function. As well as selecting if the I<sup>2</sup>C or SPI function, they are used to control the SPI Master/Slave selection and the SPI Master clock frequency. The SPI clock is a function of the system clock but can also be chosen to be sourced from CTM and  $f_{SUB}$ . If the SPI Slave Mode is selected then the clock will be supplied by an external Master device.

Bit 4      **UMD**: UART mode selection bit

- 0: SPI or I<sup>2</sup>C mode
- 1: UART mode

This bit is used to select the UART mode. When this bit is cleared to zero, the actual SPI or I<sup>2</sup>C mode can be selected using the SIM2~SIM0 bits. Note that the UMD bit must be set low for SPI or I<sup>2</sup>C mode.

Bit 3~2      **SIMDEB1~SIMDEB0**: I<sup>2</sup>C Debounce Time Selection

These bits are only available when the USIM is configured to operate in the I<sup>2</sup>C mode. Refer to the I<sup>2</sup>C register section.

- Bit 1     **SIMEN**: USIM SPI/I<sup>2</sup>C Enable Control  
           0: Disable  
           1: Enable
- The bit is the overall on/off control for the USIM SPI/I<sup>2</sup>C interface. When the SIMEN bit is cleared to zero to disable the USIM SPI/I<sup>2</sup>C interface, the SDI, SDO, SCK and SCS, or SDA and SCL lines will lose their SPI or I<sup>2</sup>C function and the USIM operating current will be reduced to a minimum value. When the bit is high the USIM SPI/I<sup>2</sup>C interface is enabled. If the USIM is configured to operate as an SPI interface via the UMD and SIM2~SIM0 bits, the contents of the SPI control registers will remain at the previous settings when the SIMEN bit changes from low to high and should therefore be first initialised by the application program. If the USIM is configured to operate as an I<sup>2</sup>C interface via the UMD and SIM2~SIM0 bits and the SIMEN bit changes from low to high, the contents of the I<sup>2</sup>C control bits such as HTX and TXAK will remain at the previous settings and should therefore be first initialised by the application program while the relevant I<sup>2</sup>C flags such as HCF, HAAS, HBB, SRW and RXAK will be set to their default states.
- Bit 0     **SIMICF**: USIM SPI Incomplete Flag  
           0: USIM SPI incomplete condition is not occurred  
           1: USIM SPI incomplete condition is occurred
- This bit is only available when the USIM is configured to operate in an SPI slave mode. If the SPI operates in the slave mode with the SIMEN and CSEN bits both being set to 1 but the  $\overline{SCS}$  line is pulled high by the external master device before the SPI data transfer is completely finished, the SIMICF bit will be set to 1 together with the TRF bit. When this condition occurs, the corresponding interrupt will occur if the interrupt function is enabled. However, the TRF bit will not be set to 1 if the SIMICF bit is set to 1 by software application program.

• **SIMC2 Register**

Bit	7	6	5	4	3	2	1	0
Name	D7	D6	CKPOLB	CKEG	MLS	CSEN	WCOL	TRF
R/W	R/W	R/W	R/W	R/W	R/W	R/W	R/W	R/W
POR	0	0	0	0	0	0	0	0

- Bit 7~6    **D7~D6**: Undefined bits  
 These bits can be read or written by the application program.
- Bit 5     **CKPOLB**: SPI clock line base condition selection  
           0: The SCK line will be high when the clock is inactive  
           1: The SCK line will be low when the clock is inactive
- The CKPOLB bit determines the base condition of the clock line, if the bit is high, then the SCK line will be low when the clock is inactive. When the CKPOLB bit is low, then the SCK line will be high when the clock is inactive.
- Bit 4     **CKEG**: SPI SCK clock active edge type selection  
           CKPOLB=0  
           0: SCK is high base level and data capture at SCK rising edge  
           1: SCK is high base level and data capture at SCK falling edge  
           CKPOLB=1  
           0: SCK is low base level and data capture at SCK falling edge  
           1: SCK is low base level and data capture at SCK rising edge
- The CKEG and CKPOLB bits are used to setup the way that the clock signal outputs and inputs data on the SPI bus. These two bits must be configured before data transfer is executed otherwise an erroneous clock edge may be generated. The CKPOLB bit determines the base condition of the clock line, if the bit is high, then the SCK line will be low when the clock is inactive. When the CKPOLB bit is low, then the SCK line will be high when the clock is inactive. The CKEG bit determines active clock edge type which depends upon the condition of CKPOLB bit.

Bit 3	<b>MLS:</b> SPI data shift order 0: LSB first 1: MSB first  This is the data shift select bit and is used to select how the data is transferred, either MSB or LSB first. Setting the bit high will select MSB first and low for LSB first.
Bit 2	<b>CSEN:</b> SPI $\overline{SCS}$ pin control 0: Disable 1: Enable  The CSEN bit is used as an enable/disable for the $\overline{SCS}$ pin. If this bit is low, then the $\overline{SCS}$ pin will be disabled and placed into a floating condition. If the bit is high the $\overline{SCS}$ pin will be enabled and used as a select pin.
Bit 1	<b>WCOL:</b> SPI write collision flag 0: No collision 1: Collision  The WCOL flag is used to detect if a data collision has occurred. If this bit is high it means that data has been attempted to be written to the SIMD register during a data transfer operation. This writing operation will be ignored if data is being transferred. The bit can be cleared by the application program.
Bit 0	<b>TRF:</b> SPI Transmit/Receive complete flag 0: SPI data is being transferred 1: SPI data transmission is completed  The TRF bit is the Transmit/Receive Complete flag and is set “1” automatically when an SPI data transmission is completed, but must set to “0” by the application program. It can be used to generate an interrupt.

### **SPI Communication**

After the SPI interface is enabled by setting the SIMEN bit high, then in the Master Mode, when data is written to the SIMD register, transmission/reception will begin simultaneously. When the data transfer is completed, the TRF flag will be set high automatically, but must be cleared using the application program. In the Slave Mode, when the clock signal from the master has been received, any data in the SIMD register will be transmitted and any data on the SDI pin will be shifted into the SIMD register. The master should output an  $\overline{SCS}$  signal to enable the slave devices before a clock signal is provided. The slave data to be transferred should be well prepared at the appropriate moment relative to the SCK signal depending upon the configurations of the CKPOLB bit and CKEG bit. The accompanying timing diagram shows the relationship between the slave data and SCK signal for various configurations of the CKPOLB and CKEG bits.

The SPI will continue to function in certain IDLE Modes if the clock source used by the SPI interface is still active.

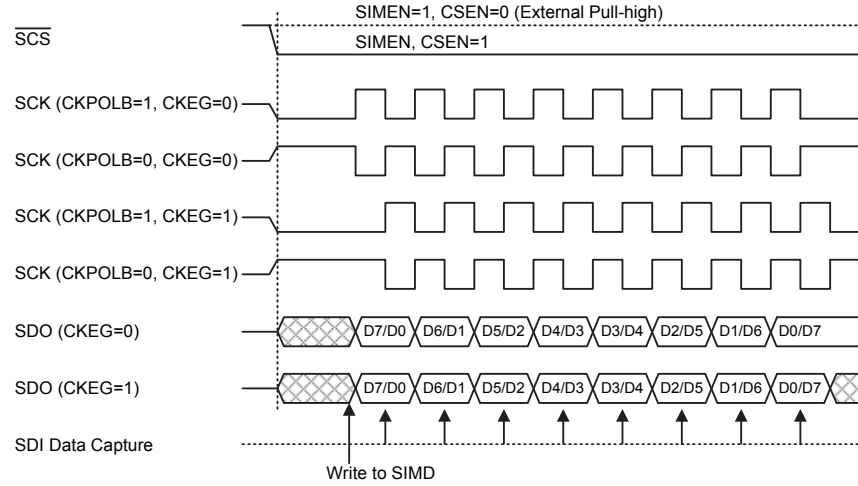

**SPI Master Mode Timing**

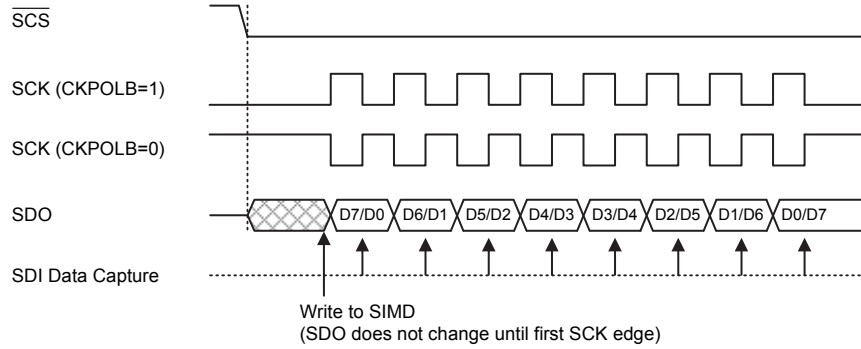

**SPI Slave Mode Timing – CKEG=0**

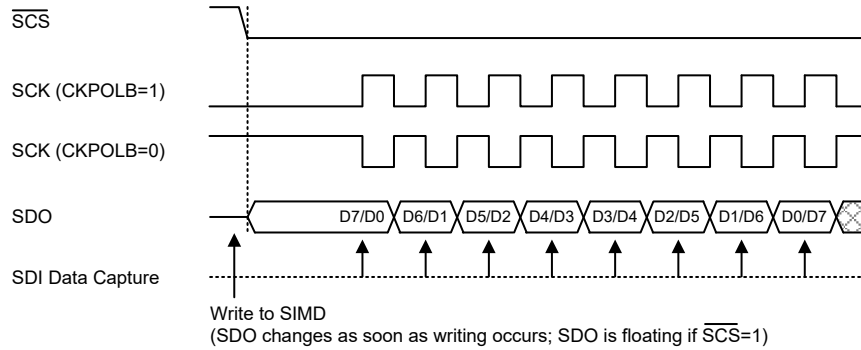

Note: For SPI slave mode, if SIMEN=1 and CSEN=0, SPI is always enabled and ignores the SCS level.

**SPI Slave Mode Timing – CKEG=1**

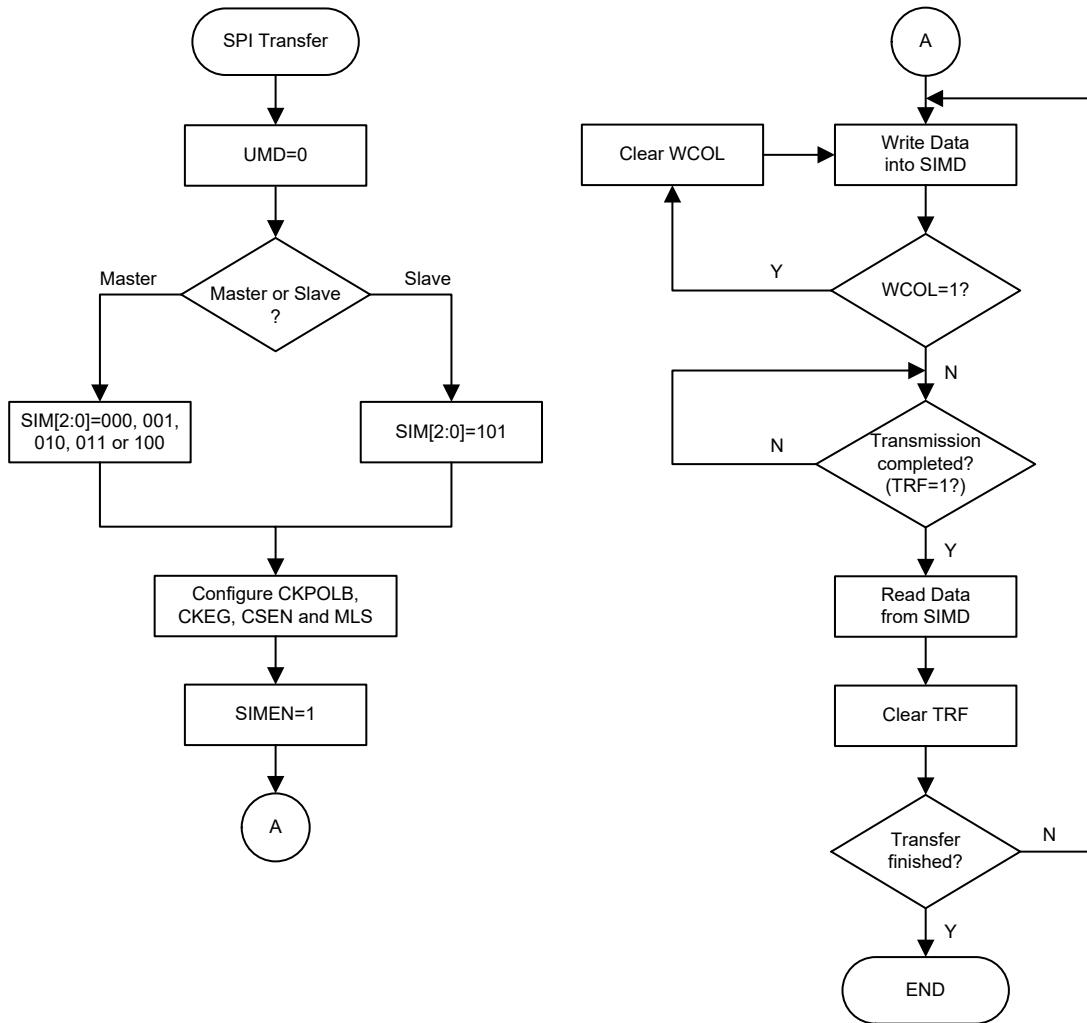

SPI Transfer Control Flowchart

### SPI Bus Enable/Disable

To enable the SPI bus, set CSEN=1 and  $\overline{\text{SCS}}=0$ , then wait for data to be written into the SIMD (TXRX buffer) register. For the Master Mode, after data has been written to the SIMD (TXRX buffer) register, then transmission or reception will start automatically. When all the data has been transferred, the TRF bit should be set. For the Slave Mode, when clock pulses are received on SCK, data in the TXRX buffer will be shifted out or data on SDI will be shifted in.

When the SPI bus is disabled, SCK, SDI, SDO and  $\overline{\text{SCS}}$  can become I/O pins or other pin-shared functions using the corresponding pin-shared control bits.

### SPI Operation Steps

All communication is carried out using the 4-line interface for either Master or Slave Mode.

The CSEN bit in the SIMC2 register controls the overall function of the SPI interface. Setting this bit high will enable the SPI interface by allowing the  $\overline{\text{SCS}}$  line to be active, which can then be used to control the SPI interface. If the CSEN bit is low, the SPI interface will be disabled and the  $\overline{\text{SCS}}$  line will be in a floating condition and can therefore not be used for control of the SPI interface. If the CSEN bit and the SIMEN bit in the SIMC0 are set high, this will place the SDI line in a floating condition and the SDO line high. If in Master Mode the SCK line will be either high or low depending upon the clock polarity selection bit CKPOLB in the SIMC2 register. If in Slave Mode the SCK line will be in a floating condition. If the SIMEN bit is low, then the bus will be disabled and  $\overline{\text{SCS}}$ , SDI, SDO and SCK will all become I/O pins or the other functions using the corresponding pin-shared control bits. In the Master Mode the Master will always generate the clock signal. The clock and data transmission will be initiated after data has been written into the SIMD register. In the Slave Mode, the clock signal will be received from an external master device for both data transmission and reception. The following sequences show the order to be followed for data transfer in both Master and Slave Mode.

#### Master Mode

- Step 1  
Select the SPI Master mode and clock source using the UMD and SIM2~SIM0 bits in the SIMC0 control register.
- Step 2  
Setup the CSEN bit and setup the MLS bit to choose if the data is MSB or LSB first, this setting must be the same with the Slave devices.
- Step 3  
Setup the SIMEN bit in the SIMC0 control register to enable the SPI interface.
- Step 4  
For write operations: write the data to the SIMD register, which will actually place the data into the TXRX buffer. Then use the SCK and  $\overline{\text{SCS}}$  lines to output the data. After this, go to step 5.  
For read operations: the data transferred in on the SDI line will be stored in the TXRX buffer until all the data has been received at which point it will be latched into the SIMD register.
- Step 5  
Check the WCOL bit if set high then a collision error has occurred so return to step 4. If equal to zero then go to the following step.
- Step 6  
Check the TRF bit or wait for a USIM SPI serial bus interrupt.
- Step 7  
Read data from the SIMD register.

- Step 8  
Clear TRF.
- Step 9  
Go to step 4.

### Slave Mode

- Step 1  
Select the SPI Slave mode using the UMD and SIM2~SIM0 bits in the SIMC0 control register
- Step 2  
Setup the CSEN bit and setup the MLS bit to choose if the data is MSB or LSB first, this setting must be the same with the Master devices.
- Step 3  
Setup the SIMEN bit in the SIMC0 control register to enable the SPI interface.
- Step 4  
For write operations: write the data to the SIMD register, which will actually place the data into the TXRX buffer. Then wait for the master clock SCK and  $\overline{\text{SCS}}$  signal. After this, go to step 5.  
For read operations: the data transferred in on the SDI line will be stored in the TXRX buffer until all the data has been received at which point it will be latched into the SIMD register.
- Step 5  
Check the WCOL bit if set high then a collision error has occurred so return to step 4. If equal to zero then go to the following step.
- Step 6  
Check the TRF bit or wait for a USIM SPI serial bus interrupt.
- Step 7  
Read data from the SIMD register.
- Step 8  
Clear TRF.
- Step 9  
Go to step 4.

### Error Detection

The WCOL bit in the SIMC2 register is provided to indicate errors during data transfer. The bit is set by the SPI serial Interface but must be cleared by the application program. This bit indicates that a data collision has occurred which happens if a write to the SIMD register takes place during a data transfer operation and will prevent the write operation from continuing.

### I<sup>2</sup>C Interface

The I<sup>2</sup>C interface is used to communicate with external peripheral devices such as sensors, EEPROM memory etc. Originally developed by Philips, it is a two line low speed serial interface for synchronous serial data transfer. The advantage of only two lines for communication, relatively simple communication protocol and the ability to accommodate multiple devices on the same bus has made it an extremely popular interface type for many applications.

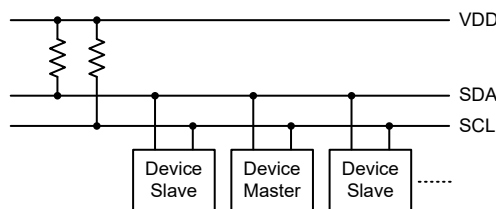

**I<sup>2</sup>C Master Slave Bus Connection**

**I<sup>2</sup>C Interface Operation**

The I<sup>2</sup>C serial interface is a two line interface, a serial data line, SDA, and serial clock line, SCL. As many devices may be connected together on the same bus, their outputs are both open drain types. For this reason it is necessary that external pull-high resistors are connected to these outputs. Note that no chip select line exists, as each device on the I<sup>2</sup>C bus is identified by a unique address which will be transmitted and received on the I<sup>2</sup>C bus.

When two devices communicate with each other on the bidirectional I<sup>2</sup>C bus, one is known as the master device and one as the slave device. Both master and slave can transmit and receive data, however, it is the master device that has overall control of the bus. For the device, which only operates in slave mode, there are two methods of transferring data on the I<sup>2</sup>C bus, the slave transmit mode and the slave receive mode. The pull-high control function pin-shared with SCL/SDA pin is still applicable even if I<sup>2</sup>C device is activated and the related internal pull-high register could be controlled by its corresponding pull-high control register.

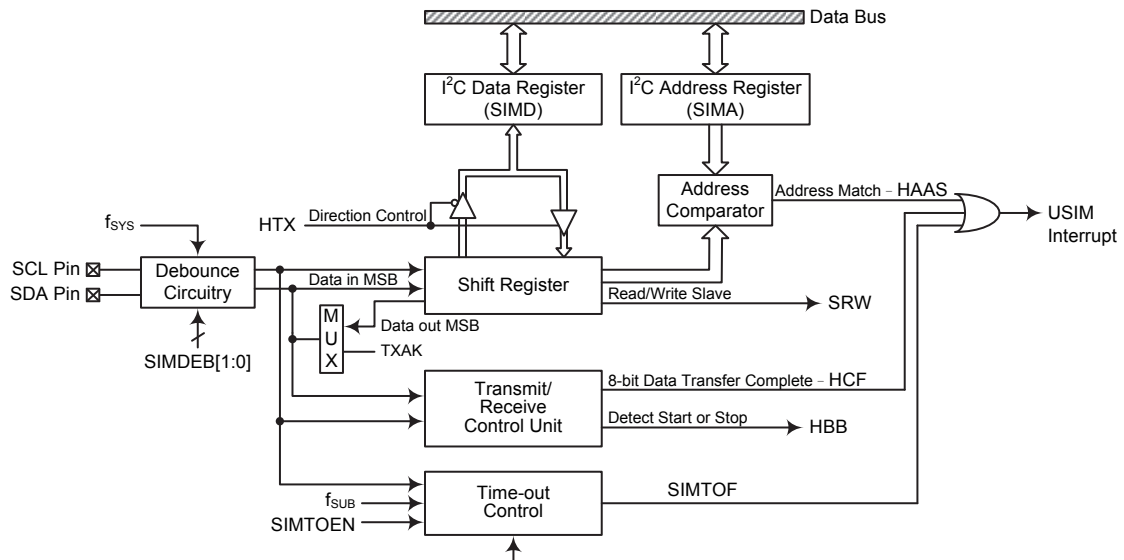

**I<sup>2</sup>C Block Diagram**

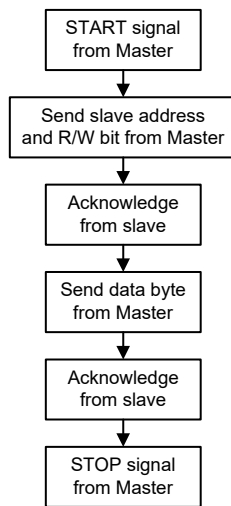

The SIMDEB1 and SIMDEB0 bits determine the debounce time of the I<sup>2</sup>C interface. This uses the internal clock to in effect add a debounce time to the external clock to reduce the possibility of glitches on the clock line causing erroneous operation. The debounce time, if selected, can be chosen to be either 2 or 4 system clocks. To achieve the required I<sup>2</sup>C data transfer speed, there exists a relationship between the system clock,  $f_{SYS}$ , and the I<sup>2</sup>C debounce time. For either the I<sup>2</sup>C Standard or Fast mode operation, users must take care of the selected system clock frequency and the configured debounce time to match the criterion shown in the following table.

I <sup>2</sup> C Debounce Time Selection	I <sup>2</sup> C Standard Mode (100kHz)	I <sup>2</sup> C Fast Mode (400kHz)
No Debounce	$f_{SYS} > 2\text{MHz}$	$f_{SYS} > 5\text{MHz}$
2 system clock debounce	$f_{SYS} > 4\text{MHz}$	$f_{SYS} > 10\text{MHz}$
4 system clock debounce	$f_{SYS} > 8\text{MHz}$	$f_{SYS} > 20\text{MHz}$

**I<sup>2</sup>C Minimum  $f_{SYS}$  Frequency Requirement**

### I<sup>2</sup>C Registers

There are three control registers associated with the I<sup>2</sup>C bus, SIMC0, SIMC1 and SIMTOC, one address register SIMA and one data register, SIMD. Note that the SIMC1, SIMD, SIMA and SIMTOC registers and their POR values are only available when the I<sup>2</sup>C mode is selected by properly configuring the UMD and SIM2~SIM0 bits in the SIMC0 register.

Register Name	Bit							
	7	6	5	4	3	2	1	0
SIMC0	SIM2	SIM1	SIM0	UMD	SIMDEB1	SIMDEB0	SIMEN	SIMICF
SIMC1	HCF	HAAS	HBB	HTX	TXAK	SRW	IAMWU	RXAK
SIMD	D7	D6	D5	D4	D3	D2	D1	D0
SIMA	SIMA6	SIMA5	SIMA4	SIMA3	SIMA2	SIMA1	SIMA0	D0
SIMTOC	SIMTOEN	SIMTOF	SIMTOS5	SIMTOS4	SIMTOS3	SIMTOS2	SIMTOS1	SIMTOS0

**I<sup>2</sup>C Register List**

### I<sup>2</sup>C Data Register

The SIMD register is used to store the data being transmitted and received. The same register is used by both the SPI and I<sup>2</sup>C functions. Before the device writes data to the I<sup>2</sup>C bus, the actual data to be transmitted must be placed in the SIMD register. After the data is received from the I<sup>2</sup>C bus, the device can read it from the SIMD register. Any transmission or reception of data from the I<sup>2</sup>C bus must be made via the SIMD register.

#### • SIMD Register

Bit	7	6	5	4	3	2	1	0
Name	D7	D6	D5	D4	D3	D2	D1	D0
R/W	R/W	R/W	R/W	R/W	R/W	R/W	R/W	R/W
POR	x	x	x	x	x	x	x	x

“x”: unknown

Bit 7~0      **D7~D0**: USIM SPI/I<sup>2</sup>C data register bit 7 ~ bit 0

### I<sup>2</sup>C Address Register

The SIMA register is also used by the SPI interface but has the name SIMC2. The SIMA register is the location where the 7-bit slave address of the slave device is stored. Bits 7~1 of the SIMA register define the device slave address. Bit 0 is not defined. When a master device, which is connected to the I<sup>2</sup>C bus, sends out an address, which matches the slave address in the SIMA register, the slave device will be selected.

• **SIMA Register**

Bit	7	6	5	4	3	2	1	0
Name	SIMA6	SIMA5	SIMA4	SIMA3	SIMA2	SIMA1	SIMA0	D0
R/W	R/W	R/W	R/W	R/W	R/W	R/W	R/W	R/W
POR	0	0	0	0	0	0	0	0

Bit 7~1     **SIMA6~SIMA0**: I<sup>2</sup>C slave address  
SIMA6~SIMA0 is the I<sup>2</sup>C slave address bit 6 ~ bit 0.

Bit 0       **D0**: Reserved bit, can be read or written

**I<sup>2</sup>C Control Registers**

There are three control registers for the I<sup>2</sup>C interface, SIMC0, SIMC1 and SIMTOC. The SIMC0 register is used to control the enable/disable function and to set the data transmission clock frequency. The SIMC1 register contains the relevant flags which are used to indicate the I<sup>2</sup>C communication status. Another register, SIMTOC, is used to control the I<sup>2</sup>C time-out function and is described in the corresponding section.

• **SIMC0 Register**

Bit	7	6	5	4	3	2	1	0
Name	SIM2	SIM1	SIM0	UMD	SIMDEB1	SIMDEB0	SIMEN	SIMICF
R/W	R/W	R/W	R/W	R/W	R/W	R/W	R/W	R/W
POR	1	1	1	0	0	0	0	0

Bit 7~5     **SIM2~SIM0**: USIM SPI/I<sup>2</sup>C Operating Mode Control  
 000: SPI master mode; SPI clock is  $f_{SYS}/4$   
 001: SPI master mode; SPI clock is  $f_{SYS}/16$   
 010: SPI master mode; SPI clock is  $f_{SYS}/64$   
 011: SPI master mode; SPI clock is  $f_{SUB}$   
 100: SPI master mode; SPI clock is CTM CCRP match frequency/2  
 101: SPI slave mode  
 110: I<sup>2</sup>C slave mode  
 111: Unused mode

When the UMD bit is cleared to zero, these bits setup the SPI or I<sup>2</sup>C operating mode of the USIM function. As well as selecting if the I<sup>2</sup>C or SPI function, they are used to control the SPI Master/Slave selection and the SPI Master clock frequency. The SPI clock is a function of the system clock but can also be chosen to be sourced from CTM and  $f_{SUB}$ . If the SPI Slave Mode is selected then the clock will be supplied by an external Master device.

Bit 4       **UMD**: UART mode selection bit  
 0: SPI or I<sup>2</sup>C mode  
 1: UART mode

This bit is used to select the UART mode. When this bit is cleared to zero, the actual SPI or I<sup>2</sup>C mode can be selected using the SIM2~SIM0 bits. Note that the UMD bit must be set low for SPI or I<sup>2</sup>C mode.

Bit 3~2     **SIMDEB1~SIMDEB0**: I<sup>2</sup>C Debounce Time Selection  
 00: No debounce  
 01: 2 system clock debounce  
 1x: 4 system clock debounce

These bits are used to select the I<sup>2</sup>C debounce time when the USIM is configured as the I<sup>2</sup>C interface function by setting the UMD bit to “0” and the SIM2~SIM0 bits to “110”.

Bit 1 **SIMEN**: USIM SPI/I<sup>2</sup>C Enable Control  
 0: Disable  
 1: Enable

The bit is the overall on/off control for the USIM SPI/I<sup>2</sup>C interface. When the SIMEN bit is cleared to zero to disable the USIM SPI/I<sup>2</sup>C interface, the SDI, SDO, SCK and SCS, or SDA and SCL lines will lose their SPI or I<sup>2</sup>C function and the USIM operating current will be reduced to a minimum value. When the bit is high the USIM SPI/I<sup>2</sup>C interface is enabled. If the USIM is configured to operate as an SPI interface via the UMD and SIM2~SIM0 bits, the contents of the SPI control registers will remain at the previous settings when the SIMEN bit changes from low to high and should therefore be first initialised by the application program. If the USIM is configured to operate as an I<sup>2</sup>C interface via the UMD and SIM2~SIM0 bits and the SIMEN bit changes from low to high, the contents of the I<sup>2</sup>C control bits such as HTX and TXAK will remain at the previous settings and should therefore be first initialised by the application program while the relevant I<sup>2</sup>C flags such as HCF, HAAS, HBB, SRW and RXAK will be set to their default states.

Bit 0 **SIMICF**: USIM SPI Incomplete Flag

This bit is only available when the USIM is configured to operate in an SPI slave mode. Refer to the SPI register section.

• **SIMC1 Register**

Bit	7	6	5	4	3	2	1	0
Name	HCF	HAAS	HBB	HTX	TXAK	SRW	IAMWU	RXAK
R/W	R	R	R	R/W	R/W	R	R/W	R
POR	1	0	0	0	0	0	0	1

Bit 7 **HCF**: I<sup>2</sup>C Bus data transfer completion flag  
 0: Data is being transferred  
 1: Completion of an 8-bit data transfer

The HCF flag is the data transfer flag. This flag will be zero when data is being transferred. Upon completion of an 8-bit data transfer the flag will go high and an interrupt will be generated.

Bit 6 **HAAS**: I<sup>2</sup>C Bus address match flag  
 0: Not address match  
 1: Address match

The HAAS flag is the address match flag. This flag is used to determine if the slave device address is the same as the master transmit address. If the addresses match then this bit will be high, if there is no match then the flag will be low.

Bit 5 **HBB**: I<sup>2</sup>C Bus busy flag  
 0: I<sup>2</sup>C Bus is not busy  
 1: I<sup>2</sup>C Bus is busy

The HBB flag is the I<sup>2</sup>C busy flag. This flag will be “1” when the I<sup>2</sup>C bus is busy which will occur when a START signal is detected. The flag will be set to “0” when the bus is free which will occur when a STOP signal is detected.

Bit 4 **HTX**: I<sup>2</sup>C slave device is transmitter or receiver selection  
 0: Slave device is the receiver  
 1: Slave device is the transmitter

Bit 3 **TXAK**: I<sup>2</sup>C Bus transmit acknowledge flag  
 0: Slave send acknowledge flag  
 1: Slave do not send acknowledge flag

The TXAK bit is the transmit acknowledge flag. After the slave device receipt of 8 bits of data, this bit will be transmitted to the bus on the 9th clock from the slave device. The slave device must always set TXAK bit to “0” before further data is received.

- Bit 2      **SRW:** I<sup>2</sup>C Slave Read/Write flag  
             0: Slave device should be in receive mode  
             1: Slave device should be in transmit mode
- The SRW flag is the I<sup>2</sup>C Slave Read/Write flag. This flag determines whether the master device wishes to transmit or receive data from the I<sup>2</sup>C bus. When the transmitted address and slave address is match, that is when the HAAS flag is set high, the slave device will check the SRW flag to determine whether it should be in transmit mode or receive mode. If the SRW flag is high, the master is requesting to read data from the bus, so the slave device should be in transmit mode. When the SRW flag is zero, the master will write data to the bus, therefore the slave device should be in receive mode to read this data.
- Bit 1      **IAMWU:** I<sup>2</sup>C Address Match Wake-up control  
             0: Disable  
             1: Enable
- This bit should be set to 1 to enable the I<sup>2</sup>C address match wake up from the SLEEP or IDLE Mode. If the IAMWU bit has been set before entering either the SLEEP or IDLE mode to enable the I<sup>2</sup>C address match wake up, then this bit must be cleared by the application program after wake-up to ensure correction device operation.
- Bit 0      **RXAK:** I<sup>2</sup>C Bus Receive acknowledge flag  
             0: Slave receive acknowledge flag  
             1: Slave does not receive acknowledge flag
- The RXAK flag is the receiver acknowledge flag. When the RXAK flag is “0”, it means that a acknowledge signal has been received at the 9th clock, after 8 bits of data have been transmitted. When the slave device in the transmit mode, the slave device checks the RXAK flag to determine if the master receiver wishes to receive the next byte. The slave transmitter will therefore continue sending out data until the RXAK flag is “1”. When this occurs, the slave transmitter will release the SDA line to allow the master to send a STOP signal to release the I<sup>2</sup>C Bus.

### I<sup>2</sup>C Bus Communication

Communication on the I<sup>2</sup>C bus requires four separate steps, a START signal, a slave device address transmission, a data transmission and finally a STOP signal. When a START signal is placed on the I<sup>2</sup>C bus, all devices on the bus will receive this signal and be notified of the imminent arrival of data on the bus. The first seven bits of the data will be the slave address with the first bit being the MSB. If the address of the slave device matches that of the transmitted address, the HAAS bit in the SIMC1 register will be set and an USIM interrupt will be generated. After entering the interrupt service routine, the slave device must first check the condition of the HAAS and SIMTOF bits to determine whether the interrupt source originates from an address match or from the completion of an 8-bit data transfer completion or from the I<sup>2</sup>C bus time-out occurrence. During a data transfer, note that after the 7-bit slave address has been transmitted, the following bit, which is the 8th bit, is the read/write bit whose value will be placed in the SRW bit. This bit will be checked by the slave device to determine whether to go into transmit or receive mode. Before any transfer of data to or from the I<sup>2</sup>C bus, the microcontroller must initialise the bus, the following are steps to achieve this:

- Step 1  
Set the UMD, SIM2~SIM0 and SIMEN bits in the SIMC0 register to “0”, “110” and “1” respectively to enable the I<sup>2</sup>C bus.
- Step 2  
Write the slave address of the device to the I<sup>2</sup>C bus address register SIMA.
- Step 3  
Set the USIME interrupt enable bit of the interrupt control register to enable the USIM interrupt.

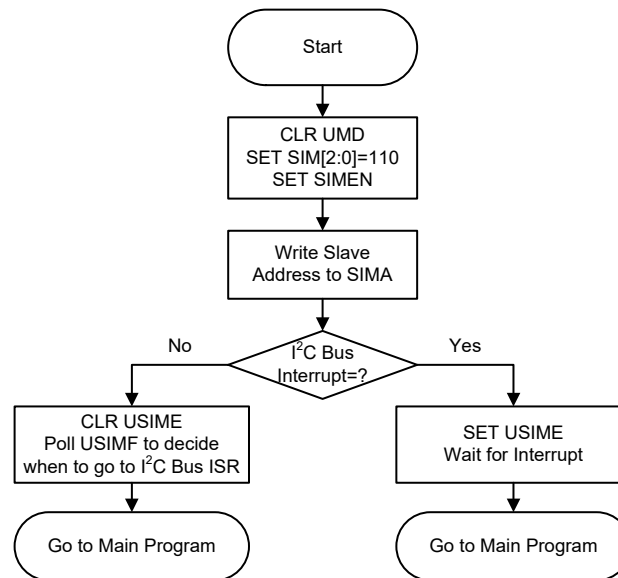

I<sup>2</sup>C Bus Initialisation Flow Chart

### I<sup>2</sup>C Bus Start Signal

The START signal can only be generated by the master device connected to the I<sup>2</sup>C bus and not by the slave device. This START signal will be detected by all devices connected to the I<sup>2</sup>C bus. When detected, this indicates that the I<sup>2</sup>C bus is busy and therefore the HBB bit will be set. A START condition occurs when a high to low transition on the SDA line takes place when the SCL line remains high.

### I<sup>2</sup>C Slave Address

The transmission of a START signal by the master will be detected by all devices on the I<sup>2</sup>C bus. To determine which slave device the master wishes to communicate with, the address of the slave device will be sent out immediately following the START signal. All slave devices, after receiving this 7-bit address data, will compare it with their own 7-bit slave address. If the address sent out by the master matches the internal address of the microcontroller slave device, then an internal USIM I<sup>2</sup>C bus interrupt signal will be generated. The next bit following the address, which is the 8th bit, defines the read/write status and will be saved to the SRW bit of the SIMC1 register. The slave device will then transmit an acknowledge bit, which is a low level, as the 9th bit. The slave device will also set the status flag HAAS when the addresses match.

As an USIM I<sup>2</sup>C bus interrupt can come from three sources, when the program enters the interrupt subroutine, the HAAS and SIMTOF bits should be examined to see whether the interrupt source has come from a matching slave address or from the completion of a data byte transfer or from the I<sup>2</sup>C bus time-out occurrence. When a slave address is matched, the device must be placed in either the transmit mode and then write data to the SIMD register, or in the receive mode where it must implement a dummy read from the SIMD register to release the SCL line.

### I<sup>2</sup>C Bus Read/Write Signal

The SRW bit in the SIMC1 register defines whether the master device wishes to read data from the I<sup>2</sup>C bus or write data to the I<sup>2</sup>C bus. The slave device should examine this bit to determine if it is to be a transmitter or a receiver. If the SRW flag is "1" then this indicates that the master device wishes to read data from the I<sup>2</sup>C bus, therefore the slave device must be setup to send data to the I<sup>2</sup>C bus as a transmitter. If the SRW flag is "0" then this indicates that the master wishes to send data to the I<sup>2</sup>C bus, therefore the slave device must be setup to read data from the I<sup>2</sup>C bus as a receiver.

**I<sup>2</sup>C Bus Slave Address Acknowledge Signal**

After the master has transmitted a calling address, any slave device on the I<sup>2</sup>C bus, whose own internal address matches the calling address, must generate an acknowledge signal. The acknowledge signal will inform the master that a slave device has accepted its calling address. If no acknowledge signal is received by the master then a STOP signal must be transmitted by the master to end the communication. When the HAAS flag is high, the addresses have matched and the slave device must check the SRW flag to determine if it is to be a transmitter or a receiver. If the SRW flag is high, the slave device should be setup to be a transmitter so the HTX bit in the SIMC1 register should be set to “1”. If the SRW flag is low, then the microcontroller slave device should be setup as a receiver and the HTX bit in the SIMC1 register should be set to “0”.

**I<sup>2</sup>C Bus Data and Acknowledge Signal**

The transmitted data is 8-bit wide and is transmitted after the slave device has acknowledged receipt of its slave address. The order of serial bit transmission is the MSB first and the LSB last. After receipt of 8 bits of data, the receiver must transmit an acknowledge signal, level “0”, before it can receive the next data byte. If the slave transmitter does not receive an acknowledge bit signal from the master receiver, then the slave transmitter will release the SDA line to allow the master to send a STOP signal to release the I<sup>2</sup>C Bus. The corresponding data will be stored in the SIMD register. If setup as a transmitter, the slave device must first write the data to be transmitted into the SIMD register. If setup as a receiver, the slave device must read the transmitted data from the SIMD register.

When the slave receiver receives the data byte, it must generate an acknowledge bit, known as TXAK, on the 9th clock. The slave device, which is setup as a transmitter will check the RXAK bit in the SIMC1 register to determine if it is to send another data byte, if not then it will release the SDA line and await the receipt of a STOP signal from the master.

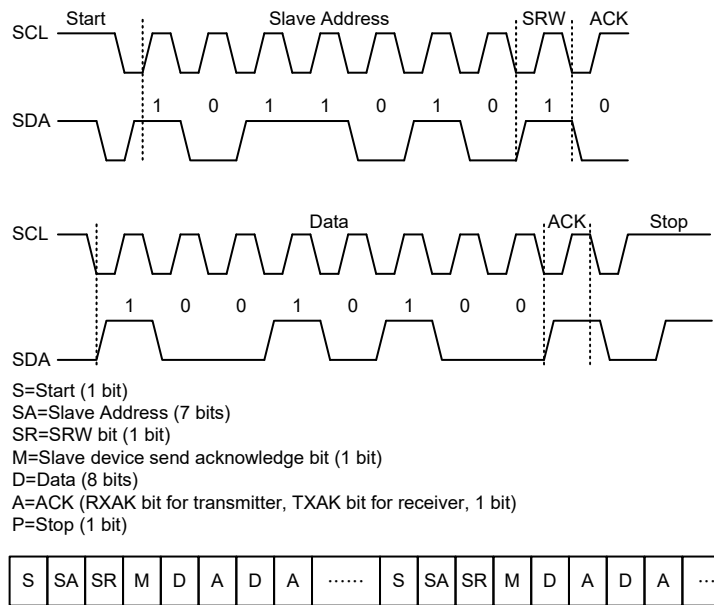

**I<sup>2</sup>C Communication Timing Diagram**

Note: When a slave address is matched, the device must be placed in either the transmit mode and then write data to the SIMD register, or in the receive mode where it must implement a dummy read from the SIMD register to release the SCL line.

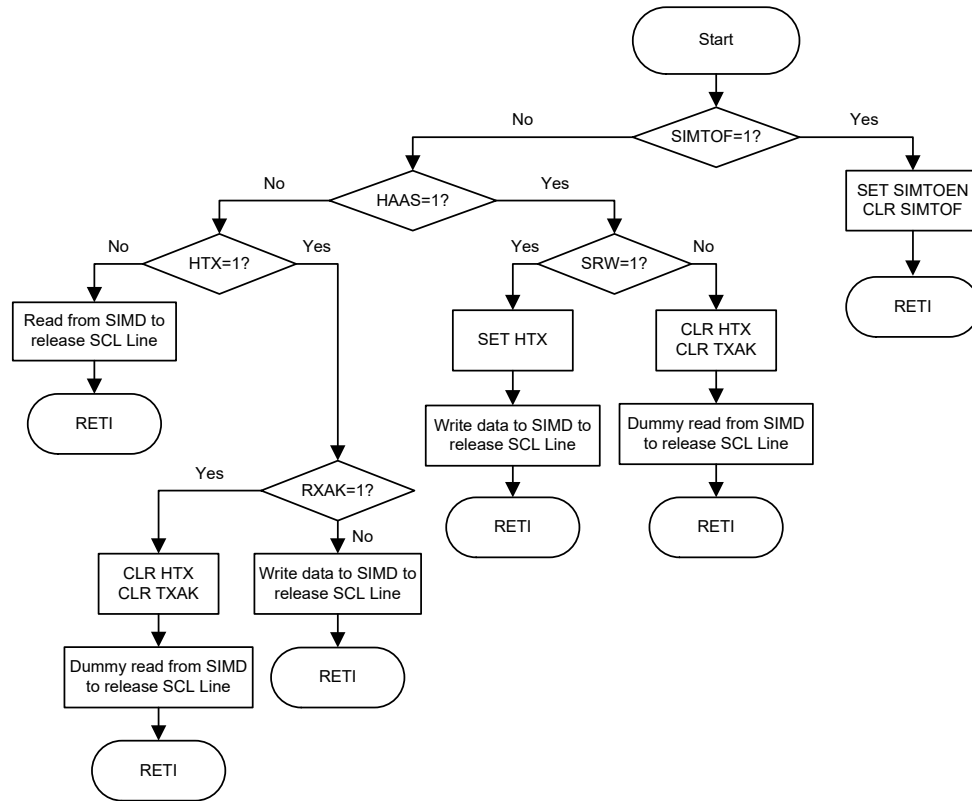

I<sup>2</sup>C Bus ISR Flow Chart

**I<sup>2</sup>C Time-out Control**

In order to reduce the problem of I<sup>2</sup>C lockup due to reception of erroneous clock sources, a time-out function is provided. If the clock source to the I<sup>2</sup>C is not received for a while, then the I<sup>2</sup>C circuitry and registers will be reset after a certain time-out period. The time-out counter starts counting on an I<sup>2</sup>C bus “START” & “address match” condition, and is cleared by an SCL falling edge. Before the next SCL falling edge arrives, if the time elapsed is greater than the time-out setup by the SIMTOC register, then a time-out condition will occur. The time-out function will stop when an I<sup>2</sup>C “STOP” condition occurs.

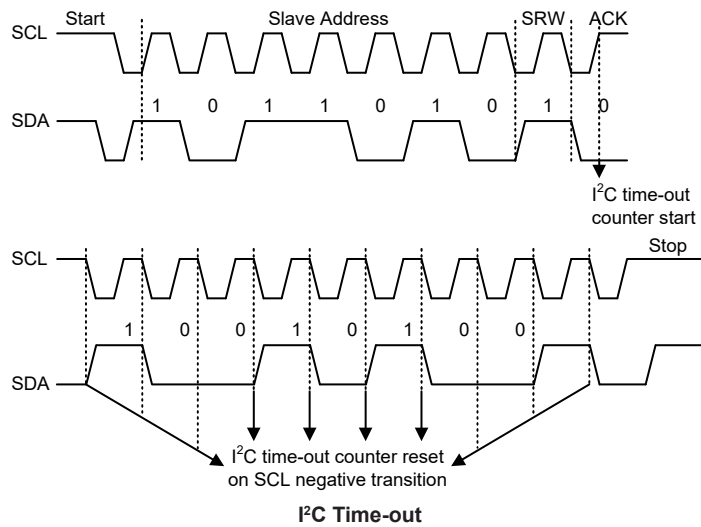

When an I<sup>2</sup>C time-out counter overflow occurs, the counter will stop and the SIMTOEN bit will be cleared to zero and the SIMTOF bit will be set high to indicate that a time-out condition has occurred. The time-out condition will also generate an interrupt which uses the USIM interrupt vector. When an I<sup>2</sup>C time-out occurs, the I<sup>2</sup>C internal circuitry will be reset and the registers will be reset into the following condition:

Registers	After I <sup>2</sup> C Time-out
SIMD, SIMA, SIMC0	No change
SIMC1	Reset to POR condition

**I<sup>2</sup>C Registers after Time-out**

The SIMTOF flag can be cleared by the application program. There are 64 time-out periods which can be selected using SIMTOS bit field in the SIMTOC register. The time-out time is given by the formula:  $((1\sim64)\times32)/f_{SUB}$ . This gives a time-out period which ranges from about 1ms to 64ms.

• **SIMTOC Register**

Bit	7	6	5	4	3	2	1	0
Name	SIMTOEN	SIMTOF	SIMTOS5	SIMTOS4	SIMTOS3	SIMTOS2	SIMTOS1	SIMTOS0
R/W	R/W	R/W	R/W	R/W	R/W	R/W	R/W	R/W
POR	0	0	0	0	0	0	0	0

Bit 7      **SIMTOEN**: USIM I<sup>2</sup>C Time-out control  
0: Disable  
1: Enable

Bit 6      **SIMTOF**: USIM I<sup>2</sup>C Time-out flag  
0: No time-out occurred  
1: Time-out occurred

This bit is set high when time-out occurs and can only be cleared by application program.

Bit 5~0    **SIMTOS5~SIMTOS0**: USIM I<sup>2</sup>C Time-out period selection  
I<sup>2</sup>C time-out clock source is  $f_{SUB}/32$ .  
I<sup>2</sup>C time-out time is equal to  $(SIMTOS[5:0]+1)\times(32/f_{SUB})$ .

## UART Interface

The device contains an integrated full-duplex asynchronous serial communications UART interface that enables communication with external devices that contain a serial interface. The UART function has many features and can transmit and receive data serially by transferring a frame of data with eight or nine data bits per transmission as well as being able to detect errors when the data is overwritten or incorrectly framed. The UART function shares the same internal interrupt vector with the SPI and I<sup>2</sup>C interfaces which can be used to indicate when a reception occurs or when a transmission terminates.

The integrated UART function contains the following features:

- Full-duplex, asynchronous communication
- 8 or 9 bits character length
- Even, odd or no parity options
- One or two stop bits
- Baud rate generator with 8-bit prescaler
- Parity, framing, noise and overrun error detection
- Support for interrupt on address detect (last character bit=1)

- Separately enabled transmitter and receiver
- 2-byte Deep FIFO Receive Data Buffer
- RX pin wake-up function
- Transmit and receive interrupts
- Interrupts can be triggered by the following conditions:
  - ♦ Transmitter Empty
  - ♦ Transmitter Idle
  - ♦ Receiver Full
  - ♦ Receiver Overrun
  - ♦ Address Mode Detect

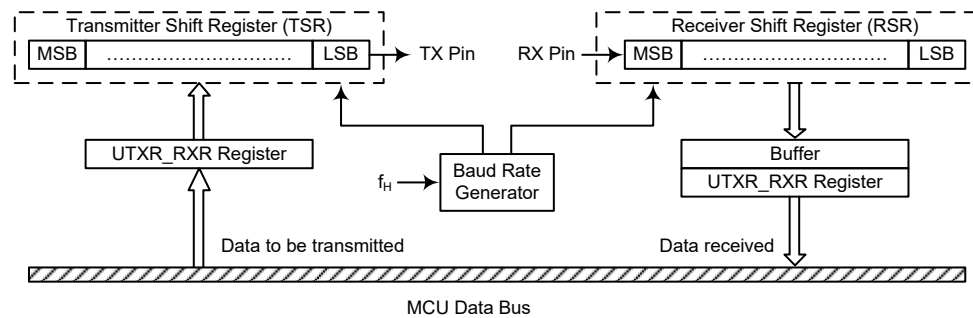

**UART Data Transfer Block Diagram**

### UART External Pins

To communicate with an external serial interface, the internal UART has two external pins known as TX and RX. The TX and RX pins are the UART transmitter and receiver pins respectively. The TX and RX pin function should first be selected by the corresponding pin-shared function selection register before the UART function is used. Along with the UMD bit, the UREN bit, the UTXEN and URXEN bits, if set, will setup these pins to their respective TX output and RX input conditions and disable any pull-high resistor option which may exist on the TX and RX pins. When the TX or RX pin function is disabled by clearing the UMD, UREN, UTXEN or URXEN bit, the TX or RX pin will be set to a floating state. At this time whether the internal pull-high resistor is connected to the TX or RX pin or not is determined by the corresponding I/O pull-high function control bit.

### UART Data Transfer Scheme

The above block diagram shows the overall data transfer structure arrangement for the UART. The actual data to be transmitted from the MCU is first transferred to the UTXR\_RXR register by the application program. The data will then be transferred to the Transmit Shift Register from where it will be shifted out, LSB first, onto the TX pin at a rate controlled by the Baud Rate Generator. Only the UTXR\_RXR register is mapped onto the MCU Data Memory, the Transmit Shift Register is not mapped and is therefore inaccessible to the application program.

Data to be received by the UART is accepted on the external RX pin, from where it is shifted in, LSB first, to the Receiver Shift Register at a rate controlled by the Baud Rate Generator. When the shift register is full, the data will then be transferred from the shift register to the internal UTXR\_RXR register, where it is buffered and can be manipulated by the application program. Only the UTXR\_RXR register is mapped onto the MCU Data Memory, the Receiver Shift Register is not mapped and is therefore inaccessible to the application program.

It should be noted that the actual register for data transmission and reception only exists as a single shared register in the Data Memory. This shared register known as the UTXR\_RXR register is used for both data transmission and data reception.

### UART Status and Control Registers

There are six control registers associated with the UART function. The UMD bit in the SIMC0 register can be used to select the UART mode. The UUSR, UUCR1 and UUCR2 registers control the overall function of the UART, while the UBRG register controls the Baud rate. The actual data to be transmitted and received on the serial interface is managed through the UTXR\_RXR data register. Note that UART related registers and their POR values are only available when the UART mode is selected by setting the UMD bit in the SIMC0 register to “1”.

Register Name	Bit							
	7	6	5	4	3	2	1	0
SIMC0	SIM2	SIM1	SIM0	UMD	SIMDEB1	SIMDEB0	SIMEN	SIMICF
UUSR	UPERR	UNF	UFERR	UOERR	URIDLE	URXIF	UTIDLE	UTXIF
UUCR1	UREN	UBNO	UPREN	UPRT	USTOPS	UTXBRK	URX8	UTX8
UUCR2	UTXEN	URXEN	UBRGH	UADDEN	UWAKE	URIE	UTIIE	UTEIE
UTXR_RXR	UTXR7	UTXR6	UTXR5	UTXR4	UTXR3	UTXR2	UTXR1	UTXR0
UBRG	UBRG7	UBRG6	UBRG5	UBRG4	UBRG3	UBRG2	UBRG1	UBRG0

**UART Register List**

#### • SIMC0 Register

Bit	7	6	5	4	3	2	1	0
Name	SIM2	SIM1	SIM0	UMD	SIMDEB1	SIMDEB0	SIMEN	SIMICF
R/W	R/W	R/W	R/W	R/W	R/W	R/W	R/W	R/W
POR	1	1	1	0	0	0	0	0

- Bit 7~5     **SIM2~SIM0**: USIM SPI/I<sup>2</sup>C Operating Mode Control  
When the UMD bit is cleared to zero, these bits setup the SPI or I<sup>2</sup>C operating mode of the USIM function. Refer to the SPI or I<sup>2</sup>C register section for more details.
- Bit 4     **UMD**: UART mode selection bit  
0: SPI or I<sup>2</sup>C mode  
1: UART mode  
  
This bit is used to select the UART mode. When this bit is cleared to zero, the actual SPI or I<sup>2</sup>C mode can be selected using the SIM2~SIM0 bits. Note that the UMD bit must be set low for SPI or I<sup>2</sup>C mode.
- Bit 3~2     **SIMDEB1~SIMDEB0**: I<sup>2</sup>C Debounce Time Selection  
Refer to the I<sup>2</sup>C register section.
- Bit 1     **SIMEN**: USIM SPI/I<sup>2</sup>C Enable Control  
This bit is only available when the USIM is configured to operate in an SPI or I<sup>2</sup>C mode with the UMD bit set low. Refer to the SPI or I<sup>2</sup>C register section for more details.
- Bit 0     **SIMICF**: USIM SPI Incomplete Flag  
Refer to the SPI register section.

• **UUSR Register**

The UUSR register is the status register for the UART, which can be read by the program to determine the present status of the UART. All flags within the UUSR register are read only. Further explanation on each of the flags is given below:

Bit	7	6	5	4	3	2	1	0
Name	UPERR	UNF	UFERR	UOERR	URIDLE	URXIF	UTIDLE	UTXIF
R/W	R	R	R	R	R	R	R	R
POR	0	0	0	0	1	0	1	1

**Bit 7**      **UPERR:** Parity error flag  
                  0: No parity error is detected  
                  1: Parity error is detected  
 The UPERR flag is the parity error flag. When this read only flag is “0”, it indicates a parity error has not been detected. When the flag is “1”, it indicates that the parity of the received word is incorrect. This error flag is applicable only if Parity mode (odd or even) is selected. The flag can also be cleared by a software sequence which involves a read to the status register UUSR followed by an access to the UTXR\_RXR data register.

**Bit 6**      **UNF:** Noise flag  
                  0: No noise is detected  
                  1: Noise is detected  
 The UNF flag is the noise flag. When this read only flag is “0”, it indicates no noise condition. When the flag is “1”, it indicates that the UART has detected noise on the receiver input. The UNF flag is set during the same cycle as the URXIF flag but will not be set in the case of an overrun. The UNF flag can be cleared by a software sequence which will involve a read to the status register UUSR followed by an access to the UTXR\_RXR data register.

**Bit 5**      **UFERR:** Framing error flag  
                  0: No framing error is detected  
                  1: Framing error is detected  
 The UFERR flag is the framing error flag. When this read only flag is “0”, it indicates that there is no framing error. When the flag is “1”, it indicates that a framing error has been detected for the current character. The flag can also be cleared by a software sequence which will involve a read to the status register UUSR followed by an access to the UTXR\_RXR data register.

**Bit 4**      **UOERR:** Overrun error flag  
                  0: No overrun error is detected  
                  1: Overrun error is detected  
 The UOERR flag is the overrun error flag which indicates when the receiver buffer has overflowed. When this read only flag is “0”, it indicates that there is no overrun error. When the flag is “1”, it indicates that an overrun error occurs which will inhibit further transfers to the UTXR\_RXR receive data register. The flag is cleared by a software sequence, which is a read to the status register UUSR followed by an access to the UTXR\_RXR data register.

**Bit 3**      **URIDLE:** Receiver status  
                  0: Data reception is in progress (Data being received)  
                  1: No data reception is in progress (Receiver is idle)  
 The URIDLE flag is the receiver status flag. When this read only flag is “0”, it indicates that the receiver is between the initial detection of the start bit and the completion of the stop bit. When the flag is “1”, it indicates that the receiver is idle. Between the completion of the stop bit and the detection of the next start bit, the URIDLE bit is “1” indicating that the UART receiver is idle and the RX pin stays in logic high condition.

- Bit 2      **URXIF**: Receive UTXR\_RXR data register status  
             0: UTXR\_RXR data register is empty  
             1: UTXR\_RXR data register has available data  
 The URXIF flag is the receive data register status flag. When this read only flag is “0”, it indicates that the UTXR\_RXR read data register is empty. When the flag is “1”, it indicates that the UTXR\_RXR read data register contains new data. When the contents of the shift register are transferred to the UTXR\_RXR register, an interrupt is generated if URIE=1 in the UUCR2 register. If one or more errors are detected in the received word, the appropriate receive-related flags UNF, UFERR, and/or UPERR are set within the same clock cycle. The URXIF flag will eventually be cleared when the UUSR register is read with URXIF set, followed by a read from the UTXR\_RXR register, and if the UTXR\_RXR register has no more new data available.
- Bit 1      **UTIDLE**: Transmission idle  
             0: Data transmission is in progress (Data being transmitted)  
             1: No data transmission is in progress (Transmitter is idle)  
 The UTIDLE flag is known as the transmission complete flag. When this read only flag is “0”, it indicates that a transmission is in progress. This flag will be set high when the UTXIF flag is “1” and when there is no transmit data or break character being transmitted. When UTIDLE is equal to “1”, the TX pin becomes idle with the pin state in logic high condition. The UTIDLE flag is cleared by reading the UUSR register with UTIDLE set and then writing to the UTXR\_RXR register. The flag is not generated when a data character or a break is queued and ready to be sent.
- Bit 0      **UTXIF**: Transmit UTXR\_RXR data register status  
             0: Character is not transferred to the transmit shift register  
             1: Character has transferred to the transmit shift register (UTXR\_RXR data register is empty)  
 The UTXIF flag is the transmit data register empty flag. When this read only flag is “0”, it indicates that the character is not transferred to the transmitter shift register. When the flag is “1”, it indicates that the transmitter shift register has received a character from the UTXR\_RXR data register. The UTXIF flag is cleared by reading the UART status register (UUSR) with UTXIF set and then writing to the UTXR\_RXR data register. Note that when the UTXEN bit is set, the UTXIF flag bit will also be set since the transmit data register is not yet full.

• **UUCR1 Register**

The UUCR1 register together with the UUCR2 register are the two UART control registers that are used to set the various options for the UART function, such as overall on/off control, parity control, data transfer bit length etc. Further explanation on each of the bits is given below:

Bit	7	6	5	4	3	2	1	0
Name	UREN	UBNO	UPREN	UPRT	USTOPS	UTXBRK	URX8	UTX8
R/W	R/W	R/W	R/W	R/W	R/W	R/W	R	W
POR	0	0	0	0	0	0	x	0

“x”: unknown

- Bit 7      **UREN**: UART function enable control  
             0: Disable UART. TX and RX pins are in a floating state  
             1: Enable UART. TX and RX pins function as UART pins  
 The UREN bit is the UART enable bit. When this bit is equal to “0”, the UART will be disabled and the RX pin as well as the TX pin will be set in a floating state. When the bit is equal to “1”, the UART will be enabled if the UMD bit is set and the TX and RX pins will function as defined by the UTXEN and URXEN enable control bits.

When the UART is disabled, it will empty the buffer so any character remaining in the buffer will be discarded. In addition, the value of the baud rate counter will be reset. If the UART is disabled, all error and status flags will be reset. Also the UTXEN, URXEN, UTXBRK, URXIF, UOERR, UFERR, UPERR and UNF bits will be cleared, while the UTIDLE, UTXIF and URIDLE bits will be set. Other control bits in UUCR1, UUCR2 and UBRG registers will remain unaffected. If the UART is active and the UREN bit is cleared, all pending transmissions and receptions will be terminated and the module will be reset as defined above. When the UART is re-enabled, it will restart in the same configuration.

- Bit 6     **UBNO:** Number of data transfer bits selection  
          0: 8-bit data transfer  
          1: 9-bit data transfer
- This bit is used to select the data length format, which can have a choice of either 8-bit or 9-bit format. When this bit is equal to “1”, a 9-bit data length format will be selected. If the bit is equal to “0”, then an 8-bit data length format will be selected. If 9-bit data length format is selected, then bits URX8 and UTX8 will be used to store the 9th bit of the received and transmitted data respectively.
- Bit 5     **UPREN:** Parity function enable control  
          0: Parity function is disabled  
          1: Parity function is enabled
- This is the parity enable bit. When this bit is equal to “1”, the parity function will be enabled. If the bit is equal to “0”, then the parity function will be disabled.
- Bit 4     **UPRT:** Parity type selection bit  
          0: Even parity for parity generator  
          1: Odd parity for parity generator
- This bit is the parity type selection bit. When this bit is equal to “1”, odd parity type will be selected. If the bit is equal to “0”, then even parity type will be selected.
- Bit 3     **USTOPS:** Number of Stop bits selection  
          0: One stop bit format is used  
          1: Two stop bits format is used
- This bit determines if one or two stop bits are to be used. When this bit is equal to “1”, two stop bits are used. If this bit is equal to “0”, then only one stop bit is used.
- Bit 2     **UTXBRK:** Transmit break character  
          0: No break character is transmitted  
          1: Break characters transmit
- The UTXBRK bit is the Transmit Break Character bit. When this bit is “0”, there are no break characters and the TX pin operates normally. When the bit is “1”, there are transmit break characters and the transmitter will send logic zeros. When this bit is equal to “1”, after the buffered data has been transmitted, the transmitter output is held low for a minimum of a 13-bit length and until the UTXBRK bit is reset.
- Bit 1     **URX8:** Receive data bit 8 for 9-bit data transfer format (read only)
- This bit is only used if 9-bit data transfers are used, in which case this bit location will store the 9th bit of the received data known as URX8. The UBNO bit is used to determine whether data transfers are in 8-bit or 9-bit format.
- Bit 0     **UTX8:** Transmit data bit 8 for 9-bit data transfer format (write only)
- This bit is only used if 9-bit data transfers are used, in which case this bit location will store the 9th bit of the transmitted data known as UTX8. The UBNO bit is used to determine whether data transfers are in 8-bit or 9-bit format.

• **UUCR2 Register**

The UUCR2 register is the second of the two UART control registers and serves several purposes. One of its main functions is to control the basic enable/disable operation of the UART Transmitter and Receiver as well as enabling the various USIM UART mode interrupt sources. The register also serves to control the baud rate speed, receiver wake-up enable and the address detect enable. Further explanation on each of the bits is given below:

Bit	7	6	5	4	3	2	1	0
Name	UTXEN	URXEN	UBRGH	UADDEN	UWAKE	URIE	UTIIE	UTEIE
R/W	R/W	R/W	R/W	R/W	R/W	R/W	R/W	R/W
POR	0	0	0	0	0	0	0	0

Bit 7      **UTXEN:** UART Transmitter enabled control

- 0: UART transmitter is disabled
- 1: UART transmitter is enabled

The bit named UTXEN is the Transmitter Enable Bit. When this bit is equal to “0”, the transmitter will be disabled with any pending data transmissions being aborted. In addition the buffers will be reset. In this situation the TX pin will be set in a floating state.

If the UTXEN bit is equal to “1” and the UMD and UREN bit are also equal to “1”, the transmitter will be enabled and the TX pin will be controlled by the UART. Clearing the UTXEN bit during a transmission will cause the data transmission to be aborted and will reset the transmitter. If this situation occurs, the TX pin will be set in a floating state.

Bit 6      **URXEN:** UART Receiver enabled control

- 0: UART receiver is disabled
- 1: UART receiver is enabled

The bit named URXEN is the Receiver Enable Bit. When this bit is equal to “0”, the receiver will be disabled with any pending data receptions being aborted. In addition the receive buffers will be reset. In this situation the RX pin will be set in a floating state. If the URXEN bit is equal to “1” and the UMD and UREN bit are also equal to “1”, the receiver will be enabled and the RX pin will be controlled by the UART. Clearing the URXEN bit during a reception will cause the data reception to be aborted and will reset the receiver. If this situation occurs, the RX pin will be set in a floating state.

Bit 5      **UBRGH:** Baud Rate speed selection

- 0: Low speed baud rate
- 1: High speed baud rate

The bit named UBRGH selects the high or low speed mode of the Baud Rate Generator. This bit, together with the value placed in the baud rate register UBRG, controls the Baud Rate of the UART. If this bit is equal to “1”, the high speed mode is selected. If the bit is equal to “0”, the low speed mode is selected.

Bit 4      **UADDEN:** Address detect function enable control

- 0: Address detect function is disabled
- 1: Address detect function is enabled

The bit named UADDEN is the address detect function enable control bit. When this bit is equal to “1”, the address detect function is enabled. When it occurs, if the 8th bit, which corresponds to UTXRX7 if UBNO=0 or the 9th bit, which corresponds to URX8 if UBNO=1, has a value of “1”, then the received word will be identified as an address, rather than data. If the corresponding interrupt is enabled, an interrupt request will be generated each time the received word has the address bit set, which is the 8th or 9th bit depending on the value of UBNO. If the address bit known as the 8th or 9th bit of the received word is “0” with the address detect function being enabled, an interrupt will not be generated and the received data will be discarded.

- Bit 3      **UWAKE**: RX pin wake-up UART function enable control  
             0: RX pin wake-up UART function is disabled  
             1: RX pin wake-up UART function is enabled  
 This bit is used to control the wake-up UART function when a falling edge on the RX pin occurs. Note that this bit is only available when the UART clock ( $f_{H1}$ ) is switched off. There will be no RX pin wake-up UART function if the UART clock ( $f_{H1}$ ) exists. If the UWAKE bit is set to 1 as the UART clock ( $f_{H1}$ ) is switched off, a UART wake-up request will be initiated when a falling edge on the RX pin occurs. When this request happens and the corresponding interrupt is enabled, an RX pin wake-up UART interrupt will be generated to inform the MCU to wake up the UART function by switching on the UART clock ( $f_{H1}$ ) via the application program. Otherwise, the UART function cannot resume even if there is a falling edge on the RX pin when the UWAKE bit is cleared to “0”.
- Bit 2      **URIE**: Receiver interrupt enable control  
             0: Receiver related interrupt is disabled  
             1: Receiver related interrupt is enabled  
 This bit enables or disables the receiver interrupt. If this bit is equal to “1” and when the receiver overrun flag UOERR or receive data available flag URXIF is set, the USIM interrupt request flag USIMF will be set. If this bit is equal to “0”, the USIM interrupt request flag USIMF will not be influenced by the condition of the UOERR or URXIF flags.
- Bit 1      **UTIE**: Transmitter Idle interrupt enable control  
             0: Transmitter idle interrupt is disabled  
             1: Transmitter idle interrupt is enabled  
 This bit enables or disables the transmitter idle interrupt. If this bit is equal to “1” and when the transmitter idle flag UTIDLE is set, due to a transmitter idle condition, the USIM interrupt request flag USIMF will be set. If this bit is equal to “0”, the USIM interrupt request flag USIMF will not be influenced by the condition of the UTIDLE flag.
- Bit 0      **UTEIE**: Transmitter Empty interrupt enable control  
             0: Transmitter empty interrupt is disabled  
             1: Transmitter empty interrupt is enabled  
 This bit enables or disables the transmitter empty interrupt. If this bit is equal to “1” and when the transmitter empty flag UTXIF is set, due to a transmitter empty condition, the USIM interrupt request flag USIMF will be set. If this bit is equal to “0”, the USIM interrupt request flag USIMF will not be influenced by the condition of the UTXIF flag.

• **UTXR\_RXR Register**

The UTXR\_RXR register is the data register which is used to store the data to be transmitted on the TX pin or being received from the RX pin.

Bit	7	6	5	4	3	2	1	0
Name	UTXRX7	UTXRX6	UTXRX5	UTXRX4	UTXRX3	UTXRX2	UTXRX1	UTXRX0
R/W	R/W	R/W	R/W	R/W	R/W	R/W	R/W	R/W
POR	x	x	x	x	x	x	x	x

“x”: unknown

- Bit 7~0      **UTXRX7~UTXRX0**: UART Transmit/Receive Data bit 7 ~ bit 0

• **UBRG Register**

Bit	7	6	5	4	3	2	1	0
Name	UBRG7	UBRG6	UBRG5	UBRG4	UBRG3	UBRG2	UBRG1	UBRG0
R/W	R/W	R/W	R/W	R/W	R/W	R/W	R/W	R/W
POR	x	x	x	x	x	x	x	x

“x”: unknown

Bit 7~0      **UBRG7~UBRG0:** Baud Rate values

By programming the UBRGH bit in UUCR2 Register which allows selection of the related formula described above and programming the required value in the UBRG register, the required baud rate can be setup.

Note: Baud rate= $f_{IH}/[64 \times (N+1)]$  if UBRGH=0.

Baud rate= $f_{IH}/[16 \times (N+1)]$  if UBRGH=1.

**Baud Rate Generator**

To setup the speed of the serial data communication, the UART function contains its own dedicated baud rate generator. The baud rate is controlled by its own internal free running 8-bit timer, the period of which is determined by two factors. The first of these is the value placed in the baud rate register UBRG and the second is the value of the UBRGH bit with the control register UUCR2. The UBRGH bit decides if the baud rate generator is to be used in a high speed mode or low speed mode, which in turn determines the formula that is used to calculate the baud rate. The value N in the UBRG register which is used in the following baud rate calculation formula determines the division factor. Note that N is the decimal value placed in the UBRG register and has a range of between 0 and 255.

UUCR2 UBRGH Bit	0	1
Baud Rate (BR)	$f_{IH} / [64 (N+1)]$	$f_{IH} / [16 (N+1)]$

By programming the UBRGH bit which allows selection of the related formula and programming the required value in the UBRG register, the required baud rate can be setup. Note that because the actual baud rate is determined using a discrete value, N, placed in the UBRG register, there will be an error associated between the actual and requested value. The following example shows how the UBRG register value N and the error value can be calculated.

**Calculating the Baud Rate and Error Values**

For a clock frequency of 4MHz, and with UBRGH cleared to zero determine the UBRG register value N, the actual baud rate and the error value for a desired baud rate of 4800.

From the above table the desired baud rate  $BR=f_{IH}/[64 (N+1)]$

Re-arranging this equation gives  $N=[f_{IH}/(BR \times 64)]-1$

Giving a value for  $N=[4000000/(4800 \times 64)]-1=12.0208$

To obtain the closest value, a decimal value of 12 should be placed into the UBRG register. This gives an actual or calculated baud rate value of  $BR=4000000/[64 \times (12+1)]=4808$

Therefore the error is equal to  $(4808-4800)/4800=0.16\%$

**UART Setup and Control**

For data transfer, the UART function utilizes a non-return-to-zero, more commonly known as NRZ, format. This is composed of one start bit, eight or nine data bits, and one or two stop bits. Parity is supported by the UART hardware, and can be setup to be even, odd or no parity. For the most common data format, 8 data bits along with no parity and one stop bit, denoted as 8, N, 1, is used as the default setting, which is the setting at power-on. The number of data bits and stop bits, along with the parity, are setup by programming the corresponding UBNO, UPRT, UPREN, and USTOPS bits in the UUCR1 register. The baud rate used to transmit and receive data is setup using the internal 8-bit baud rate generator, while the data is transmitted and received LSB first. Although the

UART transmitter and receiver are functionally independent, they both use the same data format and baud rate. In all cases stop bits will be used for data transmission.

**Enabling/Disabling the UART Interface**

The basic on/off function of the internal UART function is controlled using the UREN bit in the UUCR1 register. When the UART mode is selected by setting the UMD bit in the SIMC0 register to “1”, if the UREN, UTXEN and URXEN bits are set, then these two UART pins will act as normal TX output pin and RX input pin respectively. If no data is being transmitted on the TX pin, then it will default to a logic high value.

Clearing the UREN bit will disable the TX and RX pins and allow these two pins to be used as normal I/O or other pin-shared functional pins by configuring the corresponding pin-shared control bits. When the UART function is disabled the buffer will be reset to an empty condition, at the same time discarding any remaining residual data. Disabling the UART will also reset the error and status flags with bits UTXEN, URXEN, UTXBRK, URXIF, UOERR, UFERR, UPERR and UNF being cleared while bits UTIDLE, UTXIF and URIDLE will be set. The remaining control bits in the UUCR1, UUCR2 and UBRG registers will remain unaffected. If the UREN bit in the UUCR1 register is cleared while the UART is active, then all pending transmissions and receptions will be immediately suspended and the UART will be reset to a condition as defined above. If the UART is then subsequently re-enabled, it will restart again in the same configuration.

**Data, Parity and Stop Bit Selection**

The format of the data to be transferred is composed of various factors such as data bit length, parity on/off, parity type, address bits and the number of stop bits. These factors are determined by the setup of various bits within the UUCR1 register. The UBNO bit controls the number of data bits which can be set to either 8 or 9, the UPRT bit controls the choice of odd or even parity, the UPREN bit controls the parity on/off function and the USTOPS bit decides whether one or two stop bits are to be used. The following table shows various formats for data transmission. The address bit, which is the MSB of the data byte, identifies the frame as an address character or data if the address detect function is enabled. The number of stop bits, which can be either one or two, is independent of the data length and is only used for the transmitter. There is only one stop bit for the receiver.

Start Bit	Data Bits	Address Bit	Parity Bit	Stop Bit
<b>Example of 8-bit Data Formats</b>				
1	8	0	0	1
1	7	0	1	1
1	7	1	0	1
<b>Example of 9-bit Data Formats</b>				
1	9	0	0	1
1	8	0	1	1
1	8	1	0	1

**Transmitter Receiver Data Format**

The following diagram shows the transmit and receive waveforms for both 8-bit and 9-bit data formats.

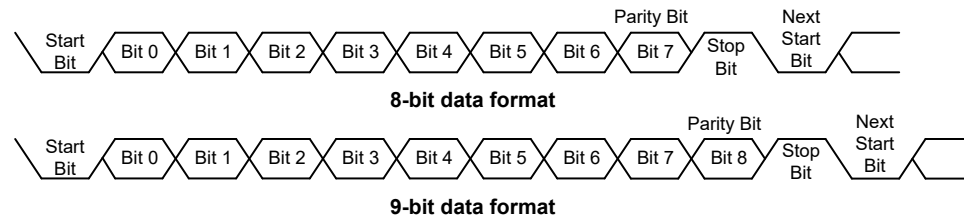

### UART Transmitter

Data word lengths of either 8 or 9 bits can be selected by programming the UBNO bit in the UUCR1 register. When UBNO bit is set, the word length will be set to 9 bits. In this case the 9th bit, which is the MSB, needs to be stored in the UTX8 bit in the UUCR1 register. At the transmitter core lies the Transmitter Shift Register, more commonly known as the TSR, whose data is obtained from the transmit data register, which is known as the UTXR\_RXR register. The data to be transmitted is loaded into this UTXR\_RXR register by the application program. The TSR register is not written to with new data until the stop bit from the previous transmission has been sent out. As soon as this stop bit has been transmitted, the TSR can then be loaded with new data from the UTXR\_RXR register, if it is available. It should be noted that the TSR register, unlike many other registers, is not directly mapped into the Data Memory area and as such is not available to the application program for direct read/write operations. An actual transmission of data will normally be enabled when the UTXEN bit is set, but the data will not be transmitted until the UTXR\_RXR register has been loaded with data and the baud rate generator has defined a shift clock source. However, the transmission can also be initiated by first loading data into the UTXR\_RXR register, after which the UTXEN bit can be set. When a transmission of data begins, the TSR is normally empty, in which case a transfer to the UTXR\_RXR register will result in an immediate transfer to the TSR. If during a transmission the UTXEN bit is cleared, the transmission will immediately cease and the transmitter will be reset. The TX output pin can then be configured as the I/O or other pin-shared function by configuring the corresponding pin-shared control bits.

### Transmitting Data

When the UART is transmitting data, the data is shifted on the TX pin from the shift register, with the least significant bit first. In the transmit mode, the UTXR\_RXR register forms a buffer between the internal bus and the transmitter shift register. It should be noted that if 9-bit data format has been selected, then the MSB will be taken from the UTX8 bit in the UUCR1 register. The steps to initiate a data transfer can be summarized as follows:

- Make the correct selection of the UBNO, UPRT, UPREN and USTOPS bits to define the required word length, parity type and number of stop bits.
- Setup the UBRG register to select the desired baud rate.
- Set the UTXEN bit to ensure that the TX pin is used as a UART transmitter pin.
- Access the UUSR register and write the data that is to be transmitted into the UTXR\_RXR register. Note that this step will clear the UTXIF bit.

This sequence of events can now be repeated to send additional data.

It should be noted that when UTXIF=0, data will be inhibited from being written to the UTXR\_RXR register. Clearing the UTXIF flag is always achieved using the following software sequence:

1. A UUSR register access
2. A UTXR\_RXR register write execution

The read-only UTXIF flag is set by the UART hardware and if set indicates that the UTXR\_RXR register is empty and that other data can now be written into the UTXR\_RXR register without overwriting the previous data. If the UTEIE bit is set then the UTXIF flag will generate an interrupt.

During a data transmission, a write instruction to the UTXR\_RXR register will place the data into the UTXR\_RXR register, which will be copied to the shift register at the end of the present transmission. When there is no data transmission in progress, a write instruction to the UTXR\_RXR register will place the data directly into the shift register, resulting in the commencement of data transmission, and the UTXIF bit being immediately set. When a frame transmission is complete, which happens after stop bits are sent or after the break frame, the UTIDLE bit will be set. To clear the UTIDLE bit the following software sequence is used:

1. A UUSR register access
2. A UTXR\_RXR register write execution

Note that both the UTXIF and UTIDLE bits are cleared by the same software sequence.

### **Transmitting Break**

If the UTXBRK bit is set high and the state keeps for a time of greater than  $[(UBRG+1) \times t_{th}]$  while UTIDLE=1, then break characters will be sent on the next transmission. Break character transmission consists of a start bit, followed by  $13 \times N$  '0' bits and stop bits, where  $N=1, 2, \text{etc.}$  If a break character is to be transmitted then the UTXBRK bit must be first set by the application program, and then cleared to generate the stop bits. Transmitting a break character will not generate a transmit interrupt. Note that a break condition length is at least 13 bits long. If the UTXBRK bit is continually kept at a logic high level then the transmitter circuitry will transmit continuous break characters. After the application program has cleared the UTXBRK bit, the transmitter will finish transmitting the last break character and subsequently send out one or two stop bits. The automatic logic highs at the end of the last break character will ensure that the start bit of the next frame is recognized.

### **UART Receiver**

The UART is capable of receiving word lengths of either 8 or 9 bits. If the UBNO bit is set, the word length will be set to 9 bits with the MSB being stored in the URX8 bit of the UUCR1 register. At the receiver core lies the Receive Serial Shift Register, commonly known as the RSR. The data which is received on the RX external input pin is sent to the data recovery block. The data recovery block operating speed is 16 times that of the baud rate, while the main receive serial shifter operates at the baud rate. After the RX pin is sampled for the stop bit, the received data in RSR is transferred to the receive data register, if the register is empty. The data which is received on the external RX input pin is sampled three times by a majority detect circuit to determine the logic level that has been placed onto the RX pin. It should be noted that the RSR register, unlike many other registers, is not directly mapped into the Data Memory area and as such is not available to the application program for direct read/write operations.

### **Receiving Data**

When the UART receiver is receiving data, the data is serially shifted in on the external RX input pin, LSB first. In the read mode, the UTXR\_RXR register forms a buffer between the internal bus and the receiver shift register. The UTXR\_RXR register is a two byte deep FIFO data buffer, where two bytes can be held in the FIFO while a third byte can continue to be received. Note that the application program must ensure that the data is read from UTXR\_RXR before the third byte has been completely shifted in, otherwise this third byte will be discarded and an overrun error UOERR will be subsequently indicated. The steps to initiate a data transfer can be summarized as follows:

- Make the correct selection of UBNO, UPRT and UPREN bits to define the word length, parity type.
- Setup the UBRG register to select the desired baud rate.
- Set the URXEN bit to ensure that the RX pin is used as a UART receiver pin.

At this point the receiver will be enabled which will begin to look for a start bit.

When a character is received the following sequence of events will occur:

- The URXIF bit in the UUSR register will be set when the UTXR\_RXR register has data available. There will be at most one more character available before an overrun error occurs.
- When the contents of the shift register have been transferred to the UTXR\_RXR register, then if the URIF bit is set, an interrupt will be generated.
- If during reception, a frame error, noise error, parity error, or an overrun error has been detected, then the error flags can be set.

The URXIF bit can be cleared using the following software sequence:

1. A UUSR register access
2. A UTXR\_RXR register read execution

### Receiving Break

Any break character received by the UART will be managed as a framing error. The receiver will count and expect a certain number of bit times as specified by the values programmed into the UBNO bit plus one stop bit. If the break is much longer than 13 bit times, the reception will be considered as complete after the number of bit times specified by UBNO plus one stop bit. The URXIF bit is set, UFERR is set, zeros are loaded into the receive data register, interrupts are generated if appropriate and the URIDLE bit is set. A break is regarded as a character that contains only zeros with the UFERR flag set. If a long break signal has been detected, the receiver will regard it as a data frame including a start bit, data bits and the invalid stop bit and the UFERR flag will be set. The receiver must wait for a valid stop bit before looking for the next start bit. The receiver will not make the assumption that the break condition on the line is the next start bit. The break character will be loaded into the buffer and no further data will be received until stop bits are received. It should be noted that the URIDLE read only flag will go high when the stop bits have not yet been received. The reception of a break character on the UART registers will result in the following:

- The framing error flag, UFERR, will be set.
- The receive data register, UTXR\_RXR, will be cleared.
- The UOERR, UNF, UPERR, URIDLE or URXIF flags will possibly be set.

### Idle Status

When the receiver is reading data, which means it will be in between the detection of a start bit and the reading of a stop bit, the receiver status flag in the UUSR register, otherwise known as the URIDLE flag, will have a zero value. In between the reception of a stop bit and the detection of the next start bit, the URIDLE flag will have a high value, which indicates the receiver is in an idle condition.

### Receiver Interrupt

The read only receive interrupt flag URXIF in the UUSR register is set by an edge generated by the receiver. An interrupt is generated if URIE=1, when a word is transferred from the Receive Shift Register, RSR, to the Receive Data Register, UTXR\_RXR. An overrun error can also generate an interrupt if URIE=1.

### Managing Receiver Errors

Several types of reception errors can occur within the UART module, the following section describes the various types and how they are managed by the UART.

#### Overrun Error – UOERR

The UTXR\_RXR register is composed of a two byte deep FIFO data buffer, where two bytes can be held in the FIFO register, while a third byte can continue to be received. Before this third byte has been entirely shifted in, the data should be read from the UTXR\_RXR register. If this is not done, the overrun error flag UOERR will be consequently indicated.

In the event of an overrun error occurring, the following will happen:

- The UOERR flag in the UUSR register will be set.
- The UTXR\_RXR contents will not be lost.
- The shift register will be overwritten.
- An interrupt will be generated if the URIE bit is set.

The UOERR flag can be cleared by an access to the UUSR register followed by a read to the UTXR\_RXR register.

### **Noise Error – UNF**

Over-sampling is used for data recovery to identify valid incoming data and noise. If noise is detected within a frame the following will occur:

- The read only noise flag, UNF, in the UUSR register will be set on the rising edge of the URXIF bit.
- Data will be transferred from the Shift register to the UTXR\_RXR register.
- No interrupt will be generated. However this bit rises at the same time as the URXIF bit which itself generates an interrupt.

Note that the UNF flag is reset by a UUSR register read operation followed by a UTXR\_RXR register read operation.

### **Framing Error – UFERR**

The read only framing error flag, UFERR, in the UUSR register, is set if a zero is detected instead of stop bits. If two stop bits are selected, both stop bits must be high; otherwise the UFERR flag will be set. The UFERR flag and the received data will be recorded in the UUSR and UTXR\_RXR registers respectively, and the flag is cleared in any reset.

### **Parity Error – UPERR**

The read only parity error flag, UPERR, in the UUSR register, is set if the parity of the received word is incorrect. This error flag is only applicable if the parity is enabled, UPREN = 1, and if the parity type, odd or even is selected. The read only UPERR flag and the received data will be recorded in the UUSR and UTXR\_RXR registers respectively. It is cleared on any reset, it should be noted that the flags, UFERR and UPERR, in the UUSR register should first be read by the application program before reading the data word.

## **UART Interrupt Structure**

Several individual UART conditions can trigger an USIM interrupt. When these conditions exist, a low pulse will be generated to get the attention of the microcontroller. These conditions are a transmitter data register empty, transmitter idle, receiver data available, receiver overrun, address detect and an RX pin wake-up. When any of these conditions are created, if the global interrupt enable bit and the USIM interrupt control bit are enabled and the stack is not full, the program will jump to its corresponding interrupt vector where it can be serviced before returning to the main program. Four of these conditions have the corresponding UUSR register flags which will generate an USIM interrupt if its associated interrupt enable control bit in the UUCR2 register is set. The two transmitter interrupt conditions have their own corresponding enable control bits, while the two receiver interrupt conditions have a shared enable control bit. These enable bits can be used to mask out individual USIM UART mode interrupt sources.

The address detect condition, which is also an USIM UART mode interrupt source, does not have an associated flag, but will generate an USIM interrupt when an address detect condition occurs if its function is enabled by setting the UADDEN bit in the UUCR2 register. An RX pin wake-up, which is also an USIM UART mode interrupt source, does not have an associated flag, but will generate an USIM interrupt if the UART clock ( $f_{H}$ ) source is switched off and the UWAKE and URIE bits in the UUCR2 register are set when a falling edge on the RX pin occurs. Note that in the event of an RX wake-up interrupt occurring, there will be a certain period of delay, commonly known as the System Start-up Time, for the oscillator to restart and stabilize before the system resumes normal operation.

Note that the UUSR register flags are read only and cannot be cleared or set by the application program, neither will they be cleared when the program jumps to the corresponding interrupt servicing routine, as is the case for some of the other interrupts. The flags will be cleared automatically when certain actions are taken by the UART, the details of which are given in the



that the UUSR, UUCR1, UUCR2, transmit and receive registers, as well as the UBRG register will not be affected. It is recommended to make sure first that the UART data transmission or reception has been finished before the microcontroller enters the IDLE or SLEEP mode.

The UART function contains a receiver RX pin wake-up function, which is enabled or disabled by the UWAKE bit in the UUCR2 register. If this bit, along with the UART mode selection bit, UMD, the UART enable bit, UREN, the receiver enable bit, URXEN and the receiver interrupt bit, URIE, are all set when the UART clock ( $f_{H}$ ) is off, then a falling edge on the RX pin will trigger an RX pin wake-up UART interrupt. Note that as it takes certain system clock cycles after a wake-up, before normal microcontroller operation resumes, any data received during this time on the RX pin will be ignored.

For a UART wake-up interrupt to occur, in addition to the bits for the wake-up being set, the global interrupt enable bit, EMI, and the USIM interrupt enable bit, USIME, must be set. If the EMI and USIME bits are not set then only a wake up event will occur and no interrupt will be generated. Note also that as it takes certain system clock cycles after a wake-up before normal microcontroller resumes, the USIM interrupt will not be generated until after this time has elapsed.

## Software Controlled LCD Driver

The device has the capability of driving external LCD panels. The common pins for LCD driving, SCOM0~SCOM3, are pin-shared with certain pin on the I/O ports. The LCD signals (COM) are generated using the application program.

### LCD Operation

An external LCD panel can be driven using the device by configuring the I/O pins as common pins. The LCD driver function is controlled using the SCOMC register which in addition to controlling the overall on/off function also controls the R-type bias current on the SCOMn pins. This enables the LCD COM driver to generate the necessary  $V_{DD}/2$  voltage levels for LCD 1/2 bias operation.

The SCOMEN bit in the SCOMC register is the overall master control for the LCD driver. The LCD SCOMn pin is selected to be used for LCD driving by the corresponding pin-shared function selection bits. Note that the Port Control register does not need to first setup the pins as outputs to enable the LCD driver operation.

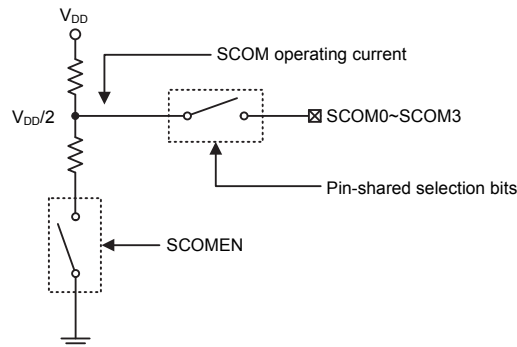

**Software Controlled LCD Driver Structure**

### LCD Bias Current Control

The LCD COM driver enables a range of selections to be provided to suit the requirement of the LCD panel which are being used. The bias current choice is implemented using the ISEL1 and ISEL0 bits in the SCOMC register.

• **SCOMC Register**

Bit	7	6	5	4	3	2	1	0
Name	—	ISEL1	ISEL0	SCOMEN	—	—	—	—
R/W	—	R/W	R/W	R/W	—	—	—	—
POR	—	0	0	0	—	—	—	—

- Bit 7 Unimplemented, read as “0”
- Bit 6~5 **ISEL1~ISEL0**: R type LCD bias current selection (@ $V_{DD}=5V$ )
  - 00:  $2 \times 100k\Omega$  (1/2 Bias),  $I_{BIAS}=25\mu A$
  - 01:  $2 \times 50k\Omega$  (1/2 Bias),  $I_{BIAS}=50\mu A$
  - 10:  $2 \times 25k\Omega$  (1/2 Bias),  $I_{BIAS}=100\mu A$
  - 11:  $2 \times 12.5k\Omega$  (1/2 Bias),  $I_{BIAS}=200\mu A$
- Bit 4 **SCOMEN**: Software controlled LCD driver enable control
  - 0: Disable
  - 1: Enable

When SCOMEN is set, it will turn on the DC path of resistor to generate 1/2  $V_{DD}$  bias voltage.
- Bit 3~0 Unimplemented, read as “0”

### Cyclic Redundancy Check – CRC

The Cyclic Redundancy Check, CRC, calculation unit is an error detection technique test algorithm used to verify data transmission or storage data correctness. A CRC calculation takes a data stream or a block of data as its input and generates a 16-bit output remainder. Ordinarily, a data stream is suffixed by a CRC code and used as a checksum when being sent or stored. Therefore, the received or restored data stream is calculated by the same generator polynomial as described in the following section.

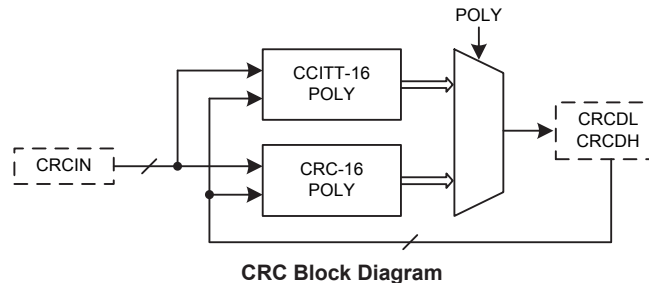

### CRC Registers

The CRC generator contains an 8-bit CRC data input register, CRCIN, and a CRC checksum register pair, CRCDH and CRCDL. The CRCIN register is used to input new data and the CRCDH and CRCDL registers are used to hold the previous CRC calculation result. A CRC control register, CRCCR, is used to select which CRC generating polynomial is used.

Register Name	Bit							
	7	6	5	4	3	2	1	0
CRCCR	—	—	—	—	—	—	—	POLY
CRCIN	D7	D6	D5	D4	D3	D2	D1	D0
CRCDL	D7	D6	D5	D4	D3	D2	D1	D0
CRCDH	D15	D14	D13	D12	D11	D10	D9	D8

**CRC Register List**

• **CRCCR Register**

Bit	7	6	5	4	3	2	1	0
Name	—	—	—	—	—	—	—	POLY
R/W	—	—	—	—	—	—	—	R/W
POR	—	—	—	—	—	—	—	0

Bit 7~1 Unimplemented, read as “0”

Bit 0 **POLY**: 16-bit CRC generating polynomial selection  
 0: CRC-CCITT:  $X^{16} + X^{12} + X^5 + 1$   
 1: CRC-16:  $X^{16} + X^{15} + X^2 + 1$

• **CRCIN Register**

Bit	7	6	5	4	3	2	1	0
Name	D7	D6	D5	D4	D3	D2	D1	D0
R/W	R/W	R/W	R/W	R/W	R/W	R/W	R/W	R/W
POR	0	0	0	0	0	0	0	0

Bit 7~0 **D7~D0**: CRC input data register

• **CRCDL Register**

Bit	7	6	5	4	3	2	1	0
Name	D7	D6	D5	D4	D3	D2	D1	D0
R/W	R/W	R/W	R/W	R/W	R/W	R/W	R/W	R/W
POR	0	0	0	0	0	0	0	0

Bit 7~0 **D7~D0**: 16-bit CRC checksum low byte data register

• **CRCDH Register**

Bit	7	6	5	4	3	2	1	0
Name	D15	D14	D13	D12	D11	D10	D9	D8
R/W	R/W	R/W	R/W	R/W	R/W	R/W	R/W	R/W
POR	0	0	0	0	0	0	0	0

Bit 7~0 **D15~D8**: 16-bit CRC checksum high byte data register

**CRC Operation**

The CRC generator provides the 16-bit CRC result calculation based on the CRC16 and CCITT CRC16 polynomials. In this CRC generator, there are only these two polynomials available for the numeric values calculation. It cannot support the 16-bit CRC calculations based on any other polynomials.

The following two expressions can be used for the CRC generating polynomial which is determined using the POLY bit in the CRC control register, CRCCR. The CRC calculation result is called as the CRC checksum, CRCSUM, and stored in the CRC checksum register pair, CRCDH and CRCDL.

- CRC-CCITT:  $X^{16} + X^{12} + X^5 + 1$ .
- CRC-16:  $X^{16} + X^{15} + X^2 + 1$ .

**CRC Computation**

Each write operation to the CRCIN register creates a combination of the previous CRC value stored in the CRCDH and CRCDL registers and the new data input. The CRC unit calculates the CRC data register value is based on byte by byte. It will take one MCU instruction cycle to calculate the CRC checksum.

### CRC Calculation Procedures

1. Clear the checksum register pair, CRCDH and CRCDL.
2. Execute an “Exclusive OR” operation with the 8-bit input data byte and the 16-bit CRCSUM high byte. The result is called the temporary CRCSUM.
3. Shift the temporary CRCSUM value left by one bit and move a “0” into the LSB.
4. Check the shifted temporary CRCSUM value after procedure 3.

If the MSB is 0, then this shifted temporary CRCSUM will be considered as a new temporary CRCSUM. Otherwise, execute an “Exclusive OR” operation with the shifted temporary CRCSUM in procedure 3 and a data “8005H”. Then the operation result will be regarded as the new temporary CRCSUM.

Note that the data to be perform an “Exclusive OR” operation is “8005H” for the CRC-16 polynomial while for the CRC-CCITT polynomial the data is “1021H”.

5. Repeat the procedure 3 ~ procedure 4 until all bits of the input data byte are completely calculated.
6. Repeat the procedure 2 ~ procedure 5 until all of the input data bytes are completely calculated. Then, the latest calculated result is the final CRC checksum, CRCSUM.

### CRC Calculation Examples

- Write 1 byte input data into the CRCIN register and the corresponding CRC checksum are individually calculated as the following table shown.

CRC Data Input	00H	01H	02H	03H	04H	05H	06H	07H
<b>CRC Polynomial</b>								
CRC-CCITT ( $X^{16}+X^{12}+X^5+1$ )	0000H	1021H	2042H	3063H	4084H	50A5H	60C6H	70E7H
CRC-16 ( $X^{16}+X^{15}+X^2+1$ )	0000H	8005H	800FH	000AH	801BH	001EH	0014H	8011H

Note: The initial value of the CRC checksum register pair, CRCDH and CRCDL, is zero before each CRC input data is written into the CRCIN register.

- Write 4 bytes input data into the CRCIN register sequentially and the CRC checksum are sequentially listed in the following table.

CRC Data Input	CRCIN = 78H→56H→34H→12H
<b>CRC Polynomial</b>	
CRC-CCITT ( $X^{16}+X^{12}+X^5+1$ )	(CRCDH, CRCDL) = FF9FH→BBC3H→A367H→D0FAH
CRC-16 ( $X^{16}+X^{15}+X^2+1$ )	(CRCDH, CRCDL) = 0110h→91F1h→F2DEh→5C43h

Note: The initial value of the CRC checksum register pair, CRCDH and CRCDL, is zero before the sequential CRC data input operation.

### Program Memory CRC Checksum Calculation Example

1. Clear the checksum register pair, CRCDH and CRCDL.
2. Select the CRC-CCITT or CRC-16 polynomial as the generating polynomial using the POLY bit in the CRCCR register.
3. Execute the table read instruction to read the program memory data value.
4. Write the table data low byte into the CRCIN register and execute the CRC calculation with the current CRCSUM value. Then a new CRCSUM result will be obtained and stored in the CRC checksum register pair, CRCDH and CRCDL.
5. Write the table data high byte into the CRCIN register and execute the CRC calculation with the current CRCSUM value. Then a new CRCSUM result will be obtained and stored in the CRC checksum register pair, CRCDH and CRCDL.
6. Repeat the procedure 3 ~ procedure 5 to read the next program memory data value and execute the CRC calculation until all program memory data are read followed by the sequential CRC calculation. Then the value in the CRC checksum register pair is the final CRC calculation result.

## Interrupts

Interrupts are an important part of any microcontroller system. When an external event or an internal function such as a Timer Module or an A/D converter requires microcontroller attention, their corresponding interrupt will enforce a temporary suspension of the main program allowing the microcontroller to direct attention to their respective needs. The device contains several external interrupt and internal interrupt functions. The external interrupt is generated by the action of the external INT0~INT1 pins, while the internal interrupts are generated by various internal functions such as the TMs, Time Bases, USIM and the A/D converter, etc.

### Interrupt Registers

Overall interrupt control, which basically means the setting of request flags when certain microcontroller conditions occur and the setting of interrupt enable bits by the application program, is controlled by a series of registers, located in the Special Purpose Data Memory, as shown in the accompanying table. The registers fall into three categories. The first is the INTC0~INTC2 registers which setup the primary interrupts, the second is the MFIO~MFI1 register which setups the Multi-function interrupts. Finally there is an INTEG register to setup the external interrupt trigger edge type.

Each register contains a number of enable bits to enable or disable individual registers as well as interrupt flags to indicate the presence of an interrupt request. The naming convention of these follows a specific pattern. First is listed an abbreviated interrupt type, then the (optional) number of that interrupt followed by either an “E” for enable/disable bit or “F” for request flag.

Function	Enable Bit	Request Flag	Notes
Global	EMI	—	—
INTn Pin	INTnE	INTnF	n=0~1
Time Base	TBnE	TBnF	n=0~1
Multi-function	MFnE	MFnF	n=0~1
A/D Converter	ADE	ADF	—
USIM	USIME	USIMF	—
CTM	CTMPE	CTMPF	—
	CTMAE	CTMAF	—
STM	STMPE	STMPF	—
	STMAE	STMAF	—

**Interrupt Register Bit Naming Conventions**

Register Name	Bit							
	7	6	5	4	3	2	1	0
INTEG	—	—	—	—	INT1S1	INT1S0	INT0S1	INT0S0
INTC0	—	TB0F	INT1F	INT0F	TB0E	INT1E	INT0E	EMI
INTC1	ADF	MF1F	MF0F	TB1F	ADE	MF1E	MF0E	TB1E
INTC2	—	—	—	USIMF	—	—	—	USIME
MFIO	—	—	CTMAF	CTMPF	—	—	CTMAE	CTMPE
MFI1	—	—	STMAF	STMPF	—	—	STMAE	STMPE

**Interrupt Register List**

• **INTEG Register**

Bit	7	6	5	4	3	2	1	0
Name	—	—	—	—	INT1S1	INT1S0	INT0S1	INT0S0
R/W	—	—	—	—	R/W	R/W	R/W	R/W
POR	—	—	—	—	0	0	0	0

- Bit 7~4      Unimplemented, read as “0”
- Bit 3~2      **INT1S1~INT1S0**: Interrupt edge control for INT1 pin  
                  00: Disable  
                  01: Rising edge  
                  10: Falling edge  
                  11: Rising and falling edges
- Bit 1~0      **INT0S1~INT0S0**: Interrupt edge control for INT0 pin  
                  00: Disable  
                  01: Rising edge  
                  10: Falling edge  
                  11: Rising and falling edges

• **INTC0 Register**

Bit	7	6	5	4	3	2	1	0
Name	—	TB0F	INT1F	INT0F	TB0E	INT1E	INT0E	EMI
R/W	—	R/W	R/W	R/W	R/W	R/W	R/W	R/W
POR	—	0	0	0	0	0	0	0

- Bit 7          Unimplemented, read as “0”
- Bit 6          **TB0F**: Time Base 0 interrupt request flag  
                  0: No request  
                  1: Interrupt request
- Bit 5          **INT1F**: INT1 interrupt request flag  
                  0: No request  
                  1: Interrupt request
- Bit 4          **INT0F**: INT0 interrupt request flag  
                  0: No request  
                  1: Interrupt request
- Bit 3          **TB0E**: Time Base 0 interrupt control  
                  0: Disable  
                  1: Enable
- Bit 2          **INT1E**: INT1 interrupt control  
                  0: Disable  
                  1: Enable
- Bit 1          **INT0E**: INT0 interrupt control  
                  0: Disable  
                  1: Enable
- Bit 0          **EMI**: Global interrupt control  
                  0: Disable  
                  1: Enable

• **INTC1 Register5**

Bit	7	6	5	4	3	2	1	0
Name	ADF	MF1F	MF0F	TB1F	ADE	MF1E	MF0E	TB1E
R/W	R/W	R/W	R/W	R/W	R/W	R/W	R/W	R/W
POR	0	0	0	0	0	0	0	0

Bit 7      **ADF**: A/D Converter interrupt request flag

0: No request

1: Interrupt request

Bit 6      **MF1F**: Multi-function 1 interrupt request flag

0: No request

1: Interrupt request

Bit 5      **MF0F**: Multi-function 0 interrupt request flag

0: No request

1: Interrupt request

Bit 4      **TB1F**: Time Base 1 interrupt request flag

0: No request

1: Interrupt request

Bit 3      **ADE**: A/D Converter interrupt control

0: Disable

1: Enable

Bit 2      **MF1E**: Multi-function 1 interrupt control

0: Disable

1: Enable

Bit 1      **MF0E**: Multi-function 0 interrupt control

0: Disable

1: Enable

Bit 0      **TB1E**: Time Base 1 interrupt control

0: Disable

1: Enable

• **INTC2 Register**

Bit	7	6	5	4	3	2	1	0
Name	—	—	—	USIMF	—	—	—	USIME
R/W	—	—	—	R/W	—	—	—	R/W
POR	—	—	—	0	—	—	—	0

Bit 7~5      Unimplemented, read as “0”

Bit 4      **USIMF**: USIM interrupt request flag

0: No request

1: Interrupt request

Bit 3~1      Unimplemented, read as “0”

Bit 0      **USIME**: USIM interrupt control

0: Disable

1: Enable

• **MFI0 Register**

Bit	7	6	5	4	3	2	1	0
Name	—	—	CTMAF	CTMPF	—	—	CTMAE	CTMPE
R/W	—	—	R/W	R/W	—	—	R/W	R/W
POR	—	—	0	0	—	—	0	0

- Bit 7~6 Unimplemented, read as “0”
- Bit 5 **CTMAF**: CTM Comparator A match interrupt request flag  
0: No request  
1: Interrupt request
- Bit 4 **CTMPF**: CTM Comparator P match interrupt request flag  
0: No request  
1: Interrupt request
- Bit 3~2 Unimplemented, read as “0”
- Bit 1 **CTMAE**: CTM Comparator A match interrupt control  
0: Disable  
1: Enable
- Bit 0 **CTMPE**: CTM Comparator P match interrupt control  
0: Disable  
1: Enable

• **MFI1 Register**

Bit	7	6	5	4	3	2	1	0
Name	—	—	STMAF	STMPF	—	—	STMAE	STMPE
R/W	—	—	R/W	R/W	—	—	R/W	R/W
POR	—	—	0	0	—	—	0	0

- Bit 7~6 Unimplemented, read as “0”
- Bit 5 **STMAF**: STM Comparator A match interrupt request flag  
0: No request  
1: Interrupt request
- Bit 4 **STMPF**: STM Comparator P match interrupt request flag  
0: No request  
1: Interrupt request
- Bit 3~2 Unimplemented, read as “0”
- Bit 1 **STMAE**: STM Comparator A match interrupt control  
0: Disable  
1: Enable
- Bit 0 **STMPE**: STM Comparator P match interrupt control  
0: Disable  
1: Enable

**Interrupt Operation**

When the conditions for an interrupt event occur, such as a TM Comparator P or Comparator A match or A/D conversion completion etc., the relevant interrupt request flag will be set. Whether the request flag actually generates a program jump to the relevant interrupt vector is determined by the condition of the interrupt enable bit. If the enable bit is set high then the program will jump to its relevant vector; if the enable bit is zero then although the interrupt request flag is set an actual interrupt will not be generated and the program will not jump to the relevant interrupt vector. The global interrupt enable bit, if cleared to zero, will disable all interrupts.

When an interrupt is generated, the Program Counter, which stores the address of the next instruction to be executed, will be transferred onto the stack. The Program Counter will then be loaded with a new address which will be the value of the corresponding interrupt vector. The microcontroller will then fetch its next instruction from this interrupt vector. The instruction at this vector will usually be a “JMP” which will jump to another section of program which is known as the interrupt service routine. Here is located the code to control the appropriate interrupt. The interrupt service routine must be terminated with a “RETI”, which retrieves the original Program Counter address from the stack and allows the microcontroller to continue with normal execution at the point where the interrupt occurred.

The various interrupt enable bits, together with their associated request flags, are shown in the accompanying diagrams with their order of priority. Some interrupt sources have their own individual vector while others share the same multi-function interrupt vector. Once an interrupt subroutine is serviced, all the other interrupts will be blocked, as the global interrupt enable bit, EMI bit will be cleared automatically. This will prevent any further interrupt nesting from occurring. However, if other interrupt requests occur during this interval, although the interrupt will not be immediately serviced, the request flag will still be recorded.

If an interrupt requires immediate servicing while the program is already in another interrupt service routine, the EMI bit should be set after entering the routine, to allow interrupt nesting. If the stack is full, the interrupt request will not be acknowledged, even if the related interrupt is enabled, until the Stack Pointer is decremented. If immediate service is desired, the stack must be prevented from becoming full. In case of simultaneous requests, the accompanying diagram shows the priority that is applied. All of the interrupt request flags when set will wake-up the device if it is in SLEEP or IDLE Mode, however to prevent a wake-up from occurring the corresponding flag should be set before the device is in SLEEP or IDLE Mode.

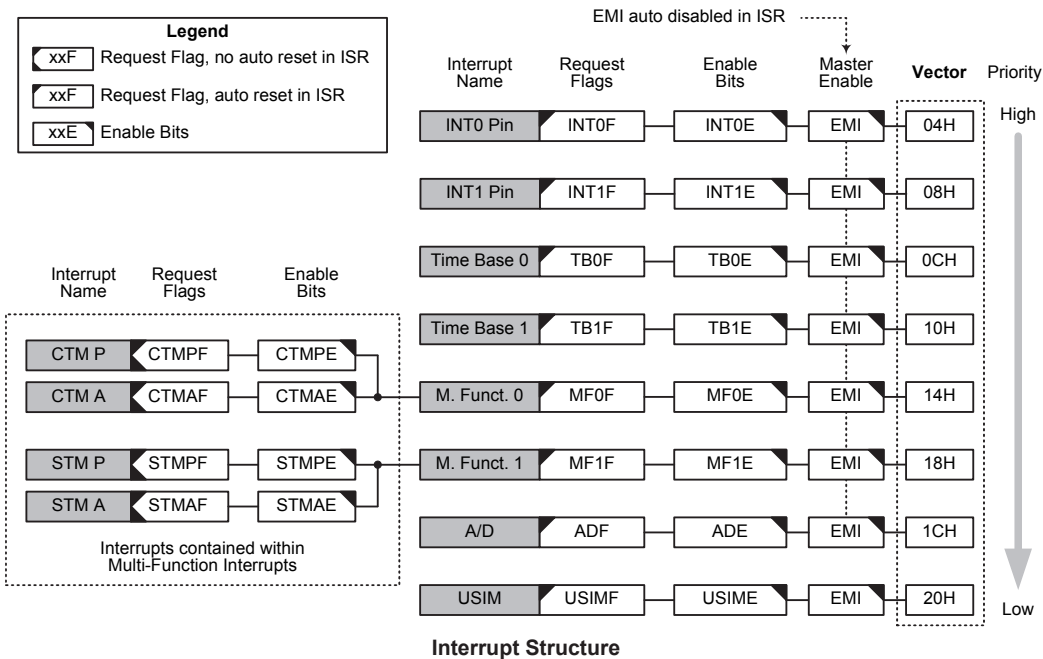

### External Interrupts

The external interrupt is controlled by signal transitions on the pins INT0~INT1. An external interrupt request will take place when the external interrupt request flags, INT0F~INT1F, is set, which will occur when a transition, whose type is chosen by the edge select bits, appears on the external interrupt pins. To allow the program to branch to their respective interrupt vector addresses, the global interrupt enable bit, EMI, and respective external interrupt enable bits, INT0E~INT1E, must first be set. Additionally the correct interrupt edge type must be selected using the INTEG register to enable the external interrupt function and to choose the trigger edge type. As the external interrupt pins are pin-shared with I/O pins, they can only be configured as external interrupt pins if their external interrupt enable bit in the corresponding interrupt register has been set and the external interrupt pin is selected by the corresponding pin-shared function selection bits. The pin must also be setup as an input by setting the corresponding bit in the port control register. When the interrupt is enabled, the stack is not full and the correct transition type appears on the external interrupt pin, a subroutine call to the external interrupt vector, will take place. When the interrupt is serviced, the external interrupt request flags, INT0F~INT1F, will be automatically reset and the EMI bit will be automatically cleared to disable other interrupts. Note that any pull-high resistor selections on the external interrupt pins will remain valid even if the pin is used as an external interrupt input.

The INTEG register is used to select the type of active edge that will trigger the external interrupt. A choice of either rising or falling or both edge types can be chosen to trigger an external interrupt. Note that the INTEG register can also be used to disable the external interrupt function.

### Time Base Interrupts

The function of the Time Base Interrupts is to provide regular time signals in the form of an internal interrupt. They are controlled by the overflow signals from their respective timer functions. When these happens their respective interrupt request flags, TB0F or TB1F will be set. To allow the program to branch to their respective interrupt vector addresses, the global interrupt enable bit, EMI and Time Base enable bits, TB0E or TB1E, must first be set. When the interrupt is enabled, the stack is not full and the Time Base overflows, a subroutine call to their respective vector locations will take place. When the interrupt is serviced, the respective interrupt request flag, TB0F or TB1F, will be automatically reset and the EMI bit will be cleared to disable other interrupts.

The purpose of the Time Base Interrupt is to provide an interrupt signal at fixed time periods. Its clock source,  $f_{PSC}$ , originates from the internal clock source  $f_{SYS}$ ,  $f_{SYS}/4$  or  $f_{SUB}$  and then passes through a divider, the division ratio of which is selected by programming the appropriate bits in the TB0C and TB1C registers to obtain longer interrupt periods whose value ranges. The clock source that generates  $f_{PSC}$ , which in turn controls the Time Base interrupt period, is selected using the CLKSEL1~CLKSEL0 bits in the PSCR register.

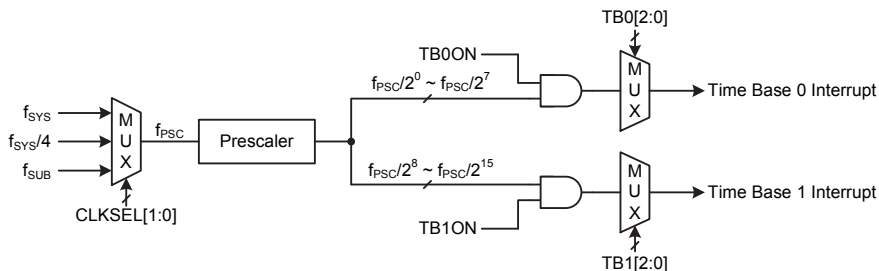

**Time Base Interrupts**

• **PSCR Register**

Bit	7	6	5	4	3	2	1	0
Name	—	—	—	—	—	—	CLKSEL1	CLKSEL0
R/W	—	—	—	—	—	—	R/W	R/W
POR	—	—	—	—	—	—	0	0

Bit 7~2 Unimplemented, read as “0”

Bit 1~0 **CLKSEL1~CLKSEL0**: Prescaler clock source selection

00:  $f_{SYS}$

01:  $f_{SYS}/4$

1x:  $f_{SUB}$

• **TB0C Register**

Bit	7	6	5	4	3	2	1	0
Name	TB0ON	—	—	—	—	TB02	TB01	TB00
R/W	R/W	—	—	—	—	R/W	R/W	R/W
POR	0	—	—	—	—	0	0	0

Bit 7 **TB0ON**: Time Base 0 Control

0: Disable

1: Enable

Bit 6~3 Unimplemented, read as “0”

Bit 2~0 **TB02~TB00**: Select Time Base 0 Time-out Period

000:  $2^0/f_{PSC}$

001:  $2^1/f_{PSC}$

010:  $2^2/f_{PSC}$

011:  $2^3/f_{PSC}$

100:  $2^4/f_{PSC}$

101:  $2^5/f_{PSC}$

110:  $2^6/f_{PSC}$

111:  $2^7/f_{PSC}$

• **TB1C Register**

Bit	7	6	5	4	3	2	1	0
Name	TB1ON	—	—	—	—	TB12	TB11	TB10
R/W	R/W	—	—	—	—	R/W	R/W	R/W
POR	0	—	—	—	—	0	0	0

Bit 7 **TB1ON**: Time Base 1 Control

0: Disable

1: Enable

Bit 6~3 Unimplemented, read as “0”

Bit 2~0 **TB12~TB10**: Select Time Base 1 Time-out Period

000:  $2^8/f_{PSC}$

001:  $2^9/f_{PSC}$

010:  $2^{10}/f_{PSC}$

011:  $2^{11}/f_{PSC}$

100:  $2^{12}/f_{PSC}$

101:  $2^{13}/f_{PSC}$

110:  $2^{14}/f_{PSC}$

111:  $2^{15}/f_{PSC}$

## Multi-function Interrupts

Within the device there are two Multi-function interrupts. Unlike the other independent interrupts, these interrupts have no independent source, but rather are formed from other existing interrupt sources, namely the TM Interrupts.

A Multi-function interrupt request will take place when any of the Multi-function interrupt request flags, MFnF are set. The Multi-function interrupt flags will be set when any of their included functions generate an interrupt request flag. When the Multi-function interrupt is enabled and the stack is not full, and either one of the interrupts contained within each of Multi-function interrupt occurs, a subroutine call to one of the Multi-function interrupt vectors will take place. When the interrupt is serviced, the related Multi-Function request flag will be automatically reset and the EMI bit will be automatically cleared to disable other interrupts.

However, it must be noted that, although the Multi-function Interrupt flags will be automatically reset when the interrupt is serviced, the request flags from the original source of the Multi-function interrupts will not be automatically reset and must be manually reset by the application program.

## TM Interrupts

The Compact Type and Standard Type TMs have two interrupts, one comes from the comparator A match situation and the other comes from the comparator P match situation. All of the TM interrupts are contained within the Multi-function Interrupts. There are two interrupt request flags, xTMPF and xTMAF, and two enable control bits, xTMPE and xTMAE. A TM interrupt request will take place when any of the TM request flags are set, a situation which occurs when a TM comparator P or A match situation happens.

To allow the program to branch to its respective interrupt vector address, the global interrupt enable bit, EMI, respective TM Interrupt enable bit, and relevant Multi-function Interrupt enable bit, MFnE, must first be set. When the interrupt is enabled, the stack is not full and a TM comparator match situation occurs, a subroutine call to the relevant Multi-function Interrupt vector locations, will take place. When the TM interrupt is serviced, the EMI bit will be automatically cleared to disable other interrupts, however only the related MFnF flag will be automatically cleared. As the TM interrupt request flags will not be automatically cleared, they have to be cleared by the application program.

## A/D Converter Interrupt

An A/D Converter Interrupt request will take place when the A/D Converter Interrupt request flag, ADF, is set, which occurs when the A/D conversion process finishes. To allow the program to branch to its respective interrupt vector address, the global interrupt enable bit, EMI, and A/D Interrupt enable bit, ADE, must first be set. When the interrupt is enabled, the stack is not full and the A/D conversion process has ended, a subroutine call to the A/D Interrupt vector, will take place. When the A/D Converter Interrupt is serviced, the A/D Interrupt flag, ADF, will be automatically cleared. The EMI bit will also be automatically cleared to disable other interrupts.

## USIM Interrupt

The Universal Serial Interface Module Interrupt, also known as the USIM interrupt, will take place when the USIM Interrupt request flag, USIMF, is set. As the USIM interface can operate in three modes which are SPI mode, I<sup>2</sup>C mode and UART mode, the USIMF flag can be set by different conditions depending on the selected interface mode.

If the SPI or I<sup>2</sup>C mode is selected, the USIM interrupt can be triggered when a byte of data has been received or transmitted by the USIM SPI or I<sup>2</sup>C interface, or an I<sup>2</sup>C slave address match occurs, or an I<sup>2</sup>C bus time-out occurs. If the UART mode is selected, several individual UART conditions including a transmitter data register empty, transmitter idle, receiver data available, receiver overrun, address

detect and an RX pin wake-up, can generate a USIM interrupt with the USIMF flag bit set high.

To allow the program to branch to its respective interrupt vector address, the global interrupt enable bit, EMI, and the Universal Serial Interface Module Interrupt enable bit, USIME, must first be set. When the interrupt is enabled, the stack is not full and any of the above described situations occurs, a subroutine call to the respective Interrupt vector, will take place. When the interrupt is serviced, the Universal Serial Interface Module Interrupt flag, USIMF, will be automatically cleared. The EMI bit will also be automatically cleared to disable other interrupts.

Note that if the USIM interrupt is triggered by the UART interface, after the interrupt has been serviced, the UUSR register flags will only be cleared when certain actions are taken by the UART, the details of which are given in the UART section.

### **Interrupt Wake-up Function**

Each of the interrupt functions has the capability of waking up the microcontroller when in the SLEEP or IDLE Mode. A wake-up is generated when an interrupt request flag changes from low to high and is independent of whether the interrupt is enabled or not. Therefore, even though the device is in the SLEEP or IDLE Mode and its system oscillator stopped, situations such as external edge transitions on the external interrupt pins may cause their respective interrupt flag to be set high and consequently generate an interrupt. Care must therefore be taken if spurious wake-up situations are to be avoided. If an interrupt wake-up function is to be disabled then the corresponding interrupt request flag should be set high before the device enters the SLEEP or IDLE Mode. The interrupt enable bits have no effect on the interrupt wake-up function.

### **Programming Considerations**

By disabling the relevant interrupt enable bits, a requested interrupt can be prevented from being serviced, however, once an interrupt request flag is set, it will remain in this condition in the interrupt register until the corresponding interrupt is serviced or until the request flag is cleared by the application program.

Where a certain interrupt is contained within a Multi-function interrupt, then when the interrupt service routine is executed, as only the Multi-function interrupt request flag, MFnF, will be automatically cleared, the individual request flag for the function needs to be cleared by the application program.

It is recommended that programs do not use the “CALL” instruction within the interrupt service subroutine. Interrupts often occur in an unpredictable manner or need to be serviced immediately. If only one stack is left and the interrupt is not well controlled, the original control sequence will be damaged once a CALL subroutine is executed in the interrupt subroutine.

Every interrupt has the capability of waking up the microcontroller when it is in the SLEEP or IDLE Mode, the wake up being generated when the interrupt request flag changes from low to high. If it is required to prevent a certain interrupt from waking up the microcontroller then its respective request flag should be first set high before enter SLEEP or IDLE Mode.

As only the Program Counter is pushed onto the stack, then when the interrupt is serviced, if the contents of the accumulator, status register or other registers are altered by the interrupt service program, their contents should be saved to the memory at the beginning of the interrupt service routine.

To return from an interrupt subroutine, either an RET or RETI instruction may be executed. The RETI instruction in addition to executing a return to the main program also automatically sets the EMI bit high to allow further interrupts. The RET instruction however only executes a return to the main program leaving the EMI bit in its present zero state and therefore disabling the execution of further interrupts.

## Application Descriptions

### Introduction

According to the battery current condition, the charger can use a Buck circuit to implement charger management. The battery charging contains constant voltage Mode and Constant current Mode. The HT45F5Q-3 device is specifically designed for battery charger applications. The above-mentioned function control can be implemented by the integrated battery charger management, these are described below.

### Functional Description

#### Operating Principle

The device contains a battery charge module which consists of three operational amplifier (OPA0~OPA2) functions, a 14-bit D/A converter (DAC0) and a 12-bit D/A converter (DAC1) functions. The open drain OPA0~OPA1 and DAC0~DAC1 are used for constant current and constant voltage signal control. The OPA output can directly drive the photo-coupler, which makes the PWM IC on the primary side can implement output power adjustment, shown in the figure below. The internal 20 times amplifier OPA2 is used to amplify the charge current signal, thus increasing the current resolution and reducing the detecting resistance power consumption. The constant voltage mode, constant current mode and constant current and constant voltage resolution increasing method are described as follows.

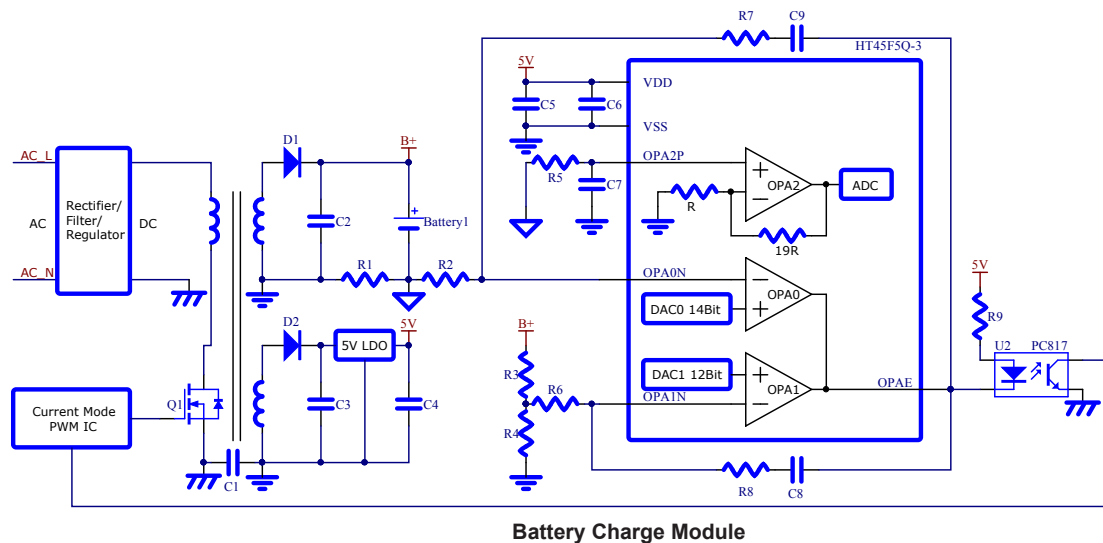

#### Constant Current Mode Description

Constant current charging means that the charge current will remain at a constant value no matter how the battery internal resistance changes. The principle is that the charge current flows through the detecting resistor R1 and in turn generates a voltage, which will be input to the OPA0 negative terminal through the OPA0N pin. The difference between the OPA0N voltage and the D/A converter voltage is amplified and then output on the OPAE pin. This output will be sent to the PWM IC via a photo-coupler. If the OPA0N voltage is lower than the DAC0 voltage, the PWM IC will increase the PWM duty cycle and vice versa.

Note: The DA0H and DA0L registers are used to set the maximum current threshold.

**Constant Voltage Mode Description**

Constant voltage charging means that the charge voltage will remain at a constant value no matter how the battery internal resistance changes. The principle is that the charge voltage B+ is divided by R3 and R4 resistors and then supplied to the OPA1N negative terminal through the OPA1N pin. The difference between the OPA1N voltage and the D/A converter voltage is amplified and then output on the OPAE pin. This output will be sent to the PWM IC via a photo-coupler. If the OPA1N voltage is lower than the DAC1 voltage, the PWM IC will increase the PWM duty cycle and vice versa.

Note: The DA1H and DA1L registers are used to set the maximum voltage threshold.

**Improving the Constant Current and Constant Voltage Resolution**

If the internal 14/12-bit D/A Converter resolution is not high enough, the OPA0 and OPA1 positive terminals can be supplied by an external divider resistor to increase the voltage and current resolution.

**Hardware Circuit**

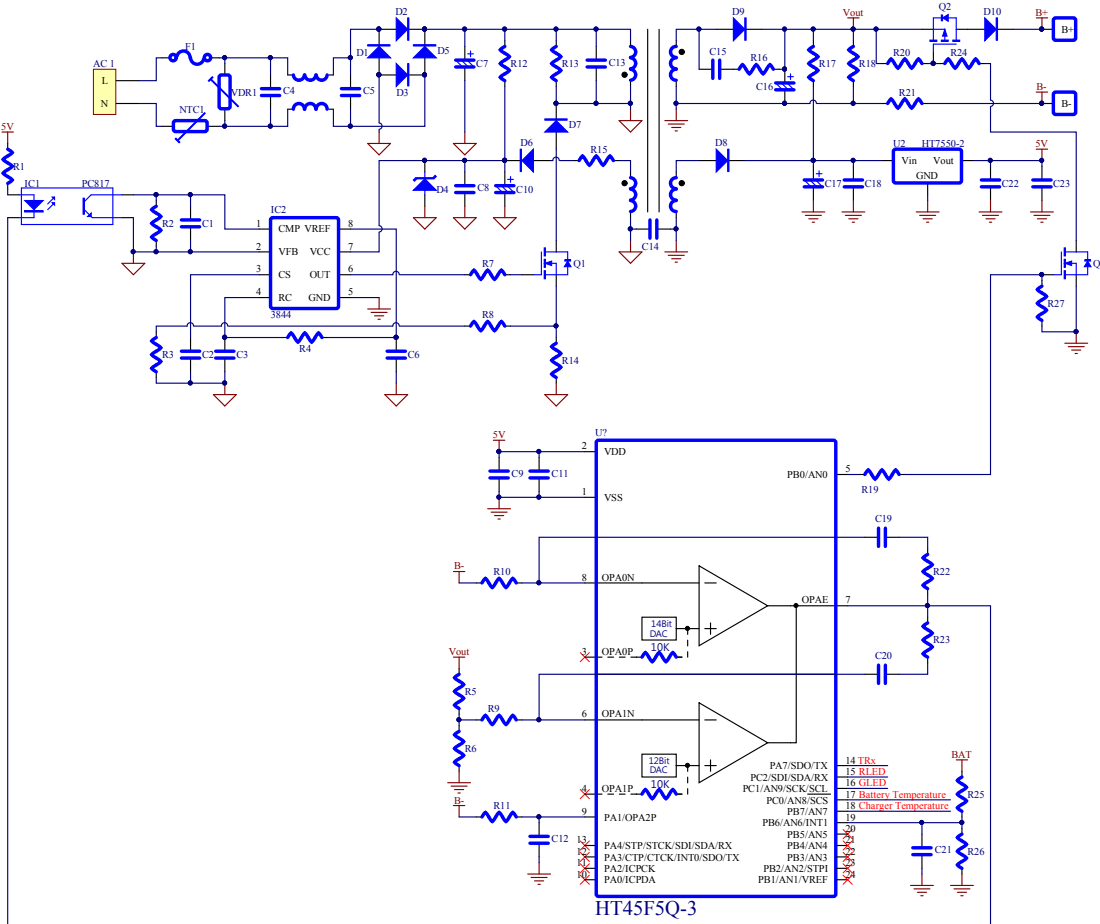

**Charger Application Circuit**

## Instruction Set

### Introduction

Central to the successful operation of any microcontroller is its instruction set, which is a set of program instruction codes that directs the microcontroller to perform certain operations. In the case of Holtek microcontroller, a comprehensive and flexible set of over 60 instructions is provided to enable programmers to implement their application with the minimum of programming overheads.

For easier understanding of the various instruction codes, they have been subdivided into several functional groupings.

### Instruction Timing

Most instructions are implemented within one instruction cycle. The exceptions to this are branch, call, or table read instructions where two instruction cycles are required. One instruction cycle is equal to 4 system clock cycles, therefore in the case of an 8MHz system oscillator, most instructions would be implemented within 0.5 $\mu$ s and branch or call instructions would be implemented within 1 $\mu$ s. Although instructions which require one more cycle to implement are generally limited to the JMP, CALL, RET, RETI and table read instructions, it is important to realize that any other instructions which involve manipulation of the Program Counter Low register or PCL will also take one more cycle to implement. As instructions which change the contents of the PCL will imply a direct jump to that new address, one more cycle will be required. Examples of such instructions would be "CLR PCL" or "MOV PCL, A". For the case of skip instructions, it must be noted that if the result of the comparison involves a skip operation then this will also take one more cycle, if no skip is involved then only one cycle is required.

### Moving and Transferring Data

The transfer of data within the microcontroller program is one of the most frequently used operations. Making use of three kinds of MOV instructions, data can be transferred from registers to the Accumulator and vice-versa as well as being able to move specific immediate data directly into the Accumulator. One of the most important data transfer applications is to receive data from the input ports and transfer data to the output ports.

### Arithmetic Operations

The ability to perform certain arithmetic operations and data manipulation is a necessary feature of most microcontroller applications. Within the Holtek microcontroller instruction set are a range of add and subtract instruction mnemonics to enable the necessary arithmetic to be carried out. Care must be taken to ensure correct handling of carry and borrow data when results exceed 255 for addition and less than 0 for subtraction. The increment and decrement instructions INC, INCA, DEC and DECA provide a simple means of increasing or decreasing by a value of one of the values in the destination specified.

## Logical and Rotate Operation

The standard logical operations such as AND, OR, XOR and CPL all have their own instruction within the Holtek microcontroller instruction set. As with the case of most instructions involving data manipulation, data must pass through the Accumulator which may involve additional programming steps. In all logical data operations, the zero flag may be set if the result of the operation is zero. Another form of logical data manipulation comes from the rotate instructions such as RR, RL, RRC and RLC which provide a simple means of rotating one bit right or left. Different rotate instructions exist depending on program requirements. Rotate instructions are useful for serial port programming applications where data can be rotated from an internal register into the Carry bit from where it can be examined and the necessary serial bit set high or low. Another application which rotate data operations are used is to implement multiplication and division calculations.

## Branches and Control Transfer

Program branching takes the form of either jumps to specified locations using the JMP instruction or to a subroutine using the CALL instruction. They differ in the sense that in the case of a subroutine call, the program must return to the instruction immediately when the subroutine has been carried out. This is done by placing a return instruction "RET" in the subroutine which will cause the program to jump back to the address right after the CALL instruction. In the case of a JMP instruction, the program simply jumps to the desired location. There is no requirement to jump back to the original jumping off point as in the case of the CALL instruction. One special and extremely useful set of branch instructions are the conditional branches. Here a decision is first made regarding the condition of a certain data memory or individual bits. Depending upon the conditions, the program will continue with the next instruction or skip over it and jump to the following instruction. These instructions are the key to decision making and branching within the program perhaps determined by the condition of certain input switches or by the condition of internal data bits.

## Bit Operations

The ability to provide single bit operations on Data Memory is an extremely flexible feature of all Holtek microcontrollers. This feature is especially useful for output port bit programming where individual bits or port pins can be directly set high or low using either the "SET [m].i" or "CLR [m].i" instructions respectively. The feature removes the need for programmers to first read the 8-bit output port, manipulate the input data to ensure that other bits are not changed and then output the port with the correct new data. This read-modify-write process is taken care of automatically when these bit operation instructions are used.

## Table Read Operations

Data storage is normally implemented by using registers. However, when working with large amounts of fixed data, the volume involved often makes it inconvenient to store the fixed data in the Data Memory. To overcome this problem, Holtek microcontrollers allow an area of Program Memory to be set as a table where data can be directly stored. A set of easy to use instructions provides the means by which this fixed data can be referenced and retrieved from the Program Memory.

## Other Operations

In addition to the above functional instructions, a range of other instructions also exist such as the "HALT" instruction for Power-down operations and instructions to control the operation of the Watchdog Timer for reliable program operations under extreme electric or electromagnetic environments. For their relevant operations, refer to the functional related sections.

## Instruction Set Summary

The following table depicts a summary of the instruction set categorised according to function and can be consulted as a basic instruction reference using the following listed conventions.

### Table Conventions

x: Bits immediate data  
 m: Data Memory address  
 A: Accumulator  
 i: 0~7 number of bits  
 addr: Program memory address

Mnemonic	Description	Cycles	Flag Affected
<b>Arithmetic</b>			
ADD A,[m]	Add Data Memory to ACC	1	Z, C, AC, OV
ADDM A,[m]	Add ACC to Data Memory	1 <sup>Note</sup>	Z, C, AC, OV
ADD A,x	Add immediate data to ACC	1	Z, C, AC, OV
ADC A,[m]	Add Data Memory to ACC with Carry	1	Z, C, AC, OV
ADCM A,[m]	Add ACC to Data memory with Carry	1 <sup>Note</sup>	Z, C, AC, OV
SUB A,x	Subtract immediate data from the ACC	1	Z, C, AC, OV
SUB A,[m]	Subtract Data Memory from ACC	1	Z, C, AC, OV
SUBM A,[m]	Subtract Data Memory from ACC with result in Data Memory	1 <sup>Note</sup>	Z, C, AC, OV
SBC A,[m]	Subtract Data Memory from ACC with Carry	1	Z, C, AC, OV
SBCM A,[m]	Subtract Data Memory from ACC with Carry, result in Data Memory	1 <sup>Note</sup>	Z, C, AC, OV
DAA [m]	Decimal adjust ACC for Addition with result in Data Memory	1 <sup>Note</sup>	C
<b>Logic Operation</b>			
AND A,[m]	Logical AND Data Memory to ACC	1	Z
OR A,[m]	Logical OR Data Memory to ACC	1	Z
XOR A,[m]	Logical XOR Data Memory to ACC	1	Z
ANDM A,[m]	Logical AND ACC to Data Memory	1 <sup>Note</sup>	Z
ORM A,[m]	Logical OR ACC to Data Memory	1 <sup>Note</sup>	Z
XORM A,[m]	Logical XOR ACC to Data Memory	1 <sup>Note</sup>	Z
AND A,x	Logical AND immediate Data to ACC	1	Z
OR A,x	Logical OR immediate Data to ACC	1	Z
XOR A,x	Logical XOR immediate Data to ACC	1	Z
CPL [m]	Complement Data Memory	1 <sup>Note</sup>	Z
CPLA [m]	Complement Data Memory with result in ACC	1	Z
<b>Increment &amp; Decrement</b>			
INCA [m]	Increment Data Memory with result in ACC	1	Z
INC [m]	Increment Data Memory	1 <sup>Note</sup>	Z
DECA [m]	Decrement Data Memory with result in ACC	1	Z
DEC [m]	Decrement Data Memory	1 <sup>Note</sup>	Z
<b>Rotate</b>			
RRA [m]	Rotate Data Memory right with result in ACC	1	None
RR [m]	Rotate Data Memory right	1 <sup>Note</sup>	None
RRCA [m]	Rotate Data Memory right through Carry with result in ACC	1	C
RRC [m]	Rotate Data Memory right through Carry	1 <sup>Note</sup>	C
RLA [m]	Rotate Data Memory left with result in ACC	1	None
RL [m]	Rotate Data Memory left	1 <sup>Note</sup>	None
RLCA [m]	Rotate Data Memory left through Carry with result in ACC	1	C
RLC [m]	Rotate Data Memory left through Carry	1 <sup>Note</sup>	C

Mnemonic	Description	Cycles	Flag Affected
<b>Data Move</b>			
MOV A,[m]	Move Data Memory to ACC	1	None
MOV [m],A	Move ACC to Data Memory	1 <sup>Note</sup>	None
MOV A,x	Move immediate data to ACC	1	None
<b>Bit Operation</b>			
CLR [m].i	Clear bit of Data Memory	1 <sup>Note</sup>	None
SET [m].i	Set bit of Data Memory	1 <sup>Note</sup>	None
<b>Branch Operation</b>			
JMP addr	Jump unconditionally	2	None
SZ [m]	Skip if Data Memory is zero	1 <sup>Note</sup>	None
SZA [m]	Skip if Data Memory is zero with data movement to ACC	1 <sup>Note</sup>	None
SZ [m].i	Skip if bit i of Data Memory is zero	1 <sup>Note</sup>	None
SNZ [m].i	Skip if bit i of Data Memory is not zero	1 <sup>Note</sup>	None
SIZ [m]	Skip if increment Data Memory is zero	1 <sup>Note</sup>	None
SDZ [m]	Skip if decrement Data Memory is zero	1 <sup>Note</sup>	None
SIZA [m]	Skip if increment Data Memory is zero with result in ACC	1 <sup>Note</sup>	None
SDZA [m]	Skip if decrement Data Memory is zero with result in ACC	1 <sup>Note</sup>	None
CALL addr	Subroutine call	2	None
RET	Return from subroutine	2	None
RET A,x	Return from subroutine and load immediate data to ACC	2	None
RETI	Return from interrupt	2	None
<b>Table Read Operation</b>			
TABRD [m]	Read table (specific page or current page) to TBLH and Data Memory	2 <sup>Note</sup>	None
TABRDL [m]	Read table (last page) to TBLH and Data Memory	2 <sup>Note</sup>	None
<b>Miscellaneous</b>			
NOP	No operation	1	None
CLR [m]	Clear Data Memory	1 <sup>Note</sup>	None
SET [m]	Set Data Memory	1 <sup>Note</sup>	None
CLR WDT	Clear Watchdog Timer	1	TO, PDF
SWAP [m]	Swap nibbles of Data Memory	1 <sup>Note</sup>	None
SWAPA [m]	Swap nibbles of Data Memory with result in ACC	1	None
HALT	Enter power down mode	1	TO, PDF

Note: 1. For skip instructions, if the result of the comparison involves a skip then two cycles are required, if no skip takes place only one cycle is required.  
2. Any instruction which changes the contents of the PCL will also require 2 cycles for execution.

## Instruction Definition

<b>ADC A,[m]</b>	Add Data Memory to ACC with Carry
Description	The contents of the specified Data Memory, Accumulator and the carry flag are added. The result is stored in the Accumulator.
Operation	$ACC \leftarrow ACC + [m] + C$
Affected flag(s)	OV, Z, AC, C
<b>ADCM A,[m]</b>	Add ACC to Data Memory with Carry
Description	The contents of the specified Data Memory, Accumulator and the carry flag are added. The result is stored in the specified Data Memory.
Operation	$[m] \leftarrow ACC + [m] + C$
Affected flag(s)	OV, Z, AC, C
<b>ADD A,[m]</b>	Add Data Memory to ACC
Description	The contents of the specified Data Memory and the Accumulator are added. The result is stored in the Accumulator.
Operation	$ACC \leftarrow ACC + [m]$
Affected flag(s)	OV, Z, AC, C
<b>ADD A,x</b>	Add immediate data to ACC
Description	The contents of the Accumulator and the specified immediate data are added. The result is stored in the Accumulator.
Operation	$ACC \leftarrow ACC + x$
Affected flag(s)	OV, Z, AC, C
<b>ADDM A,[m]</b>	Add ACC to Data Memory
Description	The contents of the specified Data Memory and the Accumulator are added. The result is stored in the specified Data Memory.
Operation	$[m] \leftarrow ACC + [m]$
Affected flag(s)	OV, Z, AC, C
<b>AND A,[m]</b>	Logical AND Data Memory to ACC
Description	Data in the Accumulator and the specified Data Memory perform a bitwise logical AND operation. The result is stored in the Accumulator.
Operation	$ACC \leftarrow ACC \text{ "AND" } [m]$
Affected flag(s)	Z
<b>AND A,x</b>	Logical AND immediate data to ACC
Description	Data in the Accumulator and the specified immediate data perform a bit wise logical AND operation. The result is stored in the Accumulator.
Operation	$ACC \leftarrow ACC \text{ "AND" } x$
Affected flag(s)	Z
<b>ANDM A,[m]</b>	Logical AND ACC to Data Memory
Description	Data in the specified Data Memory and the Accumulator perform a bitwise logical AND operation. The result is stored in the Data Memory.
Operation	$[m] \leftarrow ACC \text{ "AND" } [m]$
Affected flag(s)	Z

<b>CALL addr</b>	Subroutine call
Description	Unconditionally calls a subroutine at the specified address. The Program Counter then increments by 1 to obtain the address of the next instruction which is then pushed onto the stack. The specified address is then loaded and the program continues execution from this new address. As this instruction requires an additional operation, it is a two cycle instruction.
Operation	Stack ← Program Counter + 1 Program Counter ← addr
Affected flag(s)	None
<b>CLR [m]</b>	Clear Data Memory
Description	Each bit of the specified Data Memory is cleared to 0.
Operation	[m] ← 00H
Affected flag(s)	None
<b>CLR [m].i</b>	Clear bit of Data Memory
Description	Bit i of the specified Data Memory is cleared to 0.
Operation	[m].i ← 0
Affected flag(s)	None
<b>CLR WDT</b>	Clear Watchdog Timer
Description	The TO, PDF flags and the WDT are all cleared.
Operation	WDT cleared TO ← 0 PDF ← 0
Affected flag(s)	TO, PDF
<b>CPL [m]</b>	Complement Data Memory
Description	Each bit of the specified Data Memory is logically complemented (1's complement). Bits which previously contained a 1 are changed to 0 and vice versa.
Operation	[m] ← $\overline{[m]}$
Affected flag(s)	Z
<b>CPLA [m]</b>	Complement Data Memory with result in ACC
Description	Each bit of the specified Data Memory is logically complemented (1's complement). Bits which previously contained a 1 are changed to 0 and vice versa. The complemented result is stored in the Accumulator and the contents of the Data Memory remain unchanged.
Operation	ACC ← $\overline{[m]}$
Affected flag(s)	Z
<b>DAA [m]</b>	Decimal-Adjust ACC for addition with result in Data Memory
Description	Convert the contents of the Accumulator value to a BCD (Binary Coded Decimal) value resulting from the previous addition of two BCD variables. If the low nibble is greater than 9 or if AC flag is set, then a value of 6 will be added to the low nibble. Otherwise the low nibble remains unchanged. If the high nibble is greater than 9 or if the C flag is set, then a value of 6 will be added to the high nibble. Essentially, the decimal conversion is performed by adding 00H, 06H, 60H or 66H depending on the Accumulator and flag conditions. Only the C flag may be affected by this instruction which indicates that if the original BCD sum is greater than 100, it allows multiple precision decimal addition.
Operation	[m] ← ACC + 00H or [m] ← ACC + 06H or [m] ← ACC + 60H or [m] ← ACC + 66H
Affected flag(s)	C

<b>DEC [m]</b>	Decrement Data Memory
Description	Data in the specified Data Memory is decremented by 1.
Operation	$[m] \leftarrow [m] - 1$
Affected flag(s)	Z
<b>DECA [m]</b>	Decrement Data Memory with result in ACC
Description	Data in the specified Data Memory is decremented by 1. The result is stored in the Accumulator. The contents of the Data Memory remain unchanged.
Operation	$ACC \leftarrow [m] - 1$
Affected flag(s)	Z
<b>HALT</b>	Enter power down mode
Description	This instruction stops the program execution and turns off the system clock. The contents of the Data Memory and registers are retained. The WDT and prescaler are cleared. The power down flag PDF is set and the WDT time-out flag TO is cleared.
Operation	$TO \leftarrow 0$ $PDF \leftarrow 1$
Affected flag(s)	TO, PDF
<b>INC [m]</b>	Increment Data Memory
Description	Data in the specified Data Memory is incremented by 1.
Operation	$[m] \leftarrow [m] + 1$
Affected flag(s)	Z
<b>INCA [m]</b>	Increment Data Memory with result in ACC
Description	Data in the specified Data Memory is incremented by 1. The result is stored in the Accumulator. The contents of the Data Memory remain unchanged.
Operation	$ACC \leftarrow [m] + 1$
Affected flag(s)	Z
<b>JMP addr</b>	Jump unconditionally
Description	The contents of the Program Counter are replaced with the specified address. Program execution then continues from this new address. As this requires the insertion of a dummy instruction while the new address is loaded, it is a two cycle instruction.
Operation	Program Counter $\leftarrow$ addr
Affected flag(s)	None
<b>MOV A,[m]</b>	Move Data Memory to ACC
Description	The contents of the specified Data Memory are copied to the Accumulator.
Operation	$ACC \leftarrow [m]$
Affected flag(s)	None
<b>MOV A,x</b>	Move immediate data to ACC
Description	The immediate data specified is loaded into the Accumulator.
Operation	$ACC \leftarrow x$
Affected flag(s)	None
<b>MOV [m],A</b>	Move ACC to Data Memory
Description	The contents of the Accumulator are copied to the specified Data Memory.
Operation	$[m] \leftarrow ACC$
Affected flag(s)	None

<b>NOP</b>	No operation
Description	No operation is performed. Execution continues with the next instruction.
Operation	No operation
Affected flag(s)	None
<b>OR A,[m]</b>	Logical OR Data Memory to ACC
Description	Data in the Accumulator and the specified Data Memory perform a bitwise logical OR operation. The result is stored in the Accumulator.
Operation	ACC ← ACC "OR" [m]
Affected flag(s)	Z
<b>OR A,x</b>	Logical OR immediate data to ACC
Description	Data in the Accumulator and the specified immediate data perform a bitwise logical OR operation. The result is stored in the Accumulator.
Operation	ACC ← ACC "OR" x
Affected flag(s)	Z
<b>ORM A,[m]</b>	Logical OR ACC to Data Memory
Description	Data in the specified Data Memory and the Accumulator perform a bitwise logical OR operation. The result is stored in the Data Memory.
Operation	[m] ← ACC "OR" [m]
Affected flag(s)	Z
<b>RET</b>	Return from subroutine
Description	The Program Counter is restored from the stack. Program execution continues at the restored address.
Operation	Program Counter ← Stack
Affected flag(s)	None
<b>RET A,x</b>	Return from subroutine and load immediate data to ACC
Description	The Program Counter is restored from the stack and the Accumulator loaded with the specified immediate data. Program execution continues at the restored address.
Operation	Program Counter ← Stack ACC ← x
Affected flag(s)	None
<b>RETI</b>	Return from interrupt
Description	The Program Counter is restored from the stack and the interrupts are re-enabled by setting the EMI bit. EMI is the master interrupt global enable bit. If an interrupt was pending when the RETI instruction is executed, the pending Interrupt routine will be processed before returning to the main program.
Operation	Program Counter ← Stack EMI ← 1
Affected flag(s)	None
<b>RL [m]</b>	Rotate Data Memory left
Description	The contents of the specified Data Memory are rotated left by 1 bit with bit 7 rotated into bit 0.
Operation	[m].(i+1) ← [m].i; (i=0~6) [m].0 ← [m].7
Affected flag(s)	None

<b>RLA [m]</b>	Rotate Data Memory left with result in ACC
Description	The contents of the specified Data Memory are rotated left by 1 bit with bit 7 rotated into bit 0. The rotated result is stored in the Accumulator and the contents of the Data Memory remain unchanged.
Operation	$ACC.(i+1) \leftarrow [m].i; (i=0\sim6)$ $ACC.0 \leftarrow [m].7$
Affected flag(s)	None
<b>RLC [m]</b>	Rotate Data Memory left through Carry
Description	The contents of the specified Data Memory and the carry flag are rotated left by 1 bit. Bit 7 replaces the Carry bit and the original carry flag is rotated into bit 0.
Operation	$[m].(i+1) \leftarrow [m].i; (i=0\sim6)$ $[m].0 \leftarrow C$ $C \leftarrow [m].7$
Affected flag(s)	C
<b>RLCA [m]</b>	Rotate Data Memory left through Carry with result in ACC
Description	Data in the specified Data Memory and the carry flag are rotated left by 1 bit. Bit 7 replaces the Carry bit and the original carry flag is rotated into the bit 0. The rotated result is stored in the Accumulator and the contents of the Data Memory remain unchanged.
Operation	$ACC.(i+1) \leftarrow [m].i; (i=0\sim6)$ $ACC.0 \leftarrow C$ $C \leftarrow [m].7$
Affected flag(s)	C
<b>RR [m]</b>	Rotate Data Memory right
Description	The contents of the specified Data Memory are rotated right by 1 bit with bit 0 rotated into bit 7.
Operation	$[m].i \leftarrow [m].(i+1); (i=0\sim6)$ $[m].7 \leftarrow [m].0$
Affected flag(s)	None
<b>RRA [m]</b>	Rotate Data Memory right with result in ACC
Description	Data in the specified Data Memory is rotated right by 1 bit with bit 0 rotated into bit 7. The rotated result is stored in the Accumulator and the contents of the Data Memory remain unchanged.
Operation	$ACC.i \leftarrow [m].(i+1); (i=0\sim6)$ $ACC.7 \leftarrow [m].0$
Affected flag(s)	None
<b>RRC [m]</b>	Rotate Data Memory right through Carry
Description	The contents of the specified Data Memory and the carry flag are rotated right by 1 bit. Bit 0 replaces the Carry bit and the original carry flag is rotated into bit 7.
Operation	$[m].i \leftarrow [m].(i+1); (i=0\sim6)$ $[m].7 \leftarrow C$ $C \leftarrow [m].0$
Affected flag(s)	C

<b>RRCA [m]</b>	Rotate Data Memory right through Carry with result in ACC
Description	Data in the specified Data Memory and the carry flag are rotated right by 1 bit. Bit 0 replaces the Carry bit and the original carry flag is rotated into bit 7. The rotated result is stored in the Accumulator and the contents of the Data Memory remain unchanged.
Operation	$ACC.i \leftarrow [m].(i+1); (i=0\sim6)$ $ACC.7 \leftarrow C$ $C \leftarrow [m].0$
Affected flag(s)	C
<b>SBC A,[m]</b>	Subtract Data Memory from ACC with Carry
Description	The contents of the specified Data Memory and the complement of the carry flag are subtracted from the Accumulator. The result is stored in the Accumulator. Note that if the result of subtraction is negative, the C flag will be cleared to 0, otherwise if the result is positive or zero, the C flag will be set to 1.
Operation	$ACC \leftarrow ACC - [m] - \bar{C}$
Affected flag(s)	OV, Z, AC, C
<b>SBCM A,[m]</b>	Subtract Data Memory from ACC with Carry and result in Data Memory
Description	The contents of the specified Data Memory and the complement of the carry flag are subtracted from the Accumulator. The result is stored in the Data Memory. Note that if the result of subtraction is negative, the C flag will be cleared to 0, otherwise if the result is positive or zero, the C flag will be set to 1.
Operation	$[m] \leftarrow ACC - [m] - \bar{C}$
Affected flag(s)	OV, Z, AC, C
<b>SDZ [m]</b>	Skip if decrement Data Memory is 0
Description	The contents of the specified Data Memory are first decremented by 1. If the result is 0 the following instruction is skipped. As this requires the insertion of a dummy instruction while the next instruction is fetched, it is a two cycle instruction. If the result is not 0 the program proceeds with the following instruction.
Operation	$[m] \leftarrow [m] - 1$ Skip if $[m]=0$
Affected flag(s)	None
<b>SDZA [m]</b>	Skip if decrement Data Memory is zero with result in ACC
Description	The contents of the specified Data Memory are first decremented by 1. If the result is 0, the following instruction is skipped. The result is stored in the Accumulator but the specified Data Memory contents remain unchanged. As this requires the insertion of a dummy instruction while the next instruction is fetched, it is a two cycle instruction. If the result is not 0, the program proceeds with the following instruction.
Operation	$ACC \leftarrow [m] - 1$ Skip if $ACC=0$
Affected flag(s)	None
<b>SET [m]</b>	Set Data Memory
Description	Each bit of the specified Data Memory is set to 1.
Operation	$[m] \leftarrow FFH$
Affected flag(s)	None
<b>SET [m].i</b>	Set bit of Data Memory
Description	Bit i of the specified Data Memory is set to 1.
Operation	$[m].i \leftarrow 1$
Affected flag(s)	None

<b>SIZ [m]</b>	Skip if increment Data Memory is 0
Description	The contents of the specified Data Memory are first incremented by 1. If the result is 0, the following instruction is skipped. As this requires the insertion of a dummy instruction while the next instruction is fetched, it is a two cycle instruction. If the result is not 0 the program proceeds with the following instruction.
Operation	$[m] \leftarrow [m] + 1$ Skip if $[m]=0$
Affected flag(s)	None
<b>SIZA [m]</b>	Skip if increment Data Memory is zero with result in ACC
Description	The contents of the specified Data Memory are first incremented by 1. If the result is 0, the following instruction is skipped. The result is stored in the Accumulator but the specified Data Memory contents remain unchanged. As this requires the insertion of a dummy instruction while the next instruction is fetched, it is a two cycle instruction. If the result is not 0 the program proceeds with the following instruction.
Operation	$ACC \leftarrow [m] + 1$ Skip if $ACC=0$
Affected flag(s)	None
<b>SNZ [m].i</b>	Skip if bit i of Data Memory is not 0
Description	If bit i of the specified Data Memory is not 0, the following instruction is skipped. As this requires the insertion of a dummy instruction while the next instruction is fetched, it is a two cycle instruction. If the result is 0 the program proceeds with the following instruction.
Operation	Skip if $[m].i \neq 0$
Affected flag(s)	None
<b>SUB A,[m]</b>	Subtract Data Memory from ACC
Description	The specified Data Memory is subtracted from the contents of the Accumulator. The result is stored in the Accumulator. Note that if the result of subtraction is negative, the C flag will be cleared to 0, otherwise if the result is positive or zero, the C flag will be set to 1.
Operation	$ACC \leftarrow ACC - [m]$
Affected flag(s)	OV, Z, AC, C
<b>SUBM A,[m]</b>	Subtract Data Memory from ACC with result in Data Memory
Description	The specified Data Memory is subtracted from the contents of the Accumulator. The result is stored in the Data Memory. Note that if the result of subtraction is negative, the C flag will be cleared to 0, otherwise if the result is positive or zero, the C flag will be set to 1.
Operation	$[m] \leftarrow ACC - [m]$
Affected flag(s)	OV, Z, AC, C
<b>SUB A,x</b>	Subtract immediate data from ACC
Description	The immediate data specified by the code is subtracted from the contents of the Accumulator. The result is stored in the Accumulator. Note that if the result of subtraction is negative, the C flag will be cleared to 0, otherwise if the result is positive or zero, the C flag will be set to 1.
Operation	$ACC \leftarrow ACC - x$
Affected flag(s)	OV, Z, AC, C
<b>SWAP [m]</b>	Swap nibbles of Data Memory
Description	The low-order and high-order nibbles of the specified Data Memory are interchanged.
Operation	$[m].3\sim[m].0 \leftrightarrow [m].7\sim[m].4$
Affected flag(s)	None

<b>SWAPA [m]</b>	Swap nibbles of Data Memory with result in ACC
Description	The low-order and high-order nibbles of the specified Data Memory are interchanged. The result is stored in the Accumulator. The contents of the Data Memory remain unchanged.
Operation	ACC.3~ACC.0 ← [m].7~[m].4 ACC.7~ACC.4 ← [m].3~[m].0
Affected flag(s)	None
<b>SZ [m]</b>	Skip if Data Memory is 0
Description	If the contents of the specified Data Memory is 0, the following instruction is skipped. As this requires the insertion of a dummy instruction while the next instruction is fetched, it is a two cycle instruction. If the result is not 0 the program proceeds with the following instruction.
Operation	Skip if [m]=0
Affected flag(s)	None
<b>SZA [m]</b>	Skip if Data Memory is 0 with data movement to ACC
Description	The contents of the specified Data Memory are copied to the Accumulator. If the value is zero, the following instruction is skipped. As this requires the insertion of a dummy instruction while the next instruction is fetched, it is a two cycle instruction. If the result is not 0 the program proceeds with the following instruction.
Operation	ACC ← [m] Skip if [m]=0
Affected flag(s)	None
<b>SZ [m].i</b>	Skip if bit i of Data Memory is 0
Description	If bit i of the specified Data Memory is 0, the following instruction is skipped. As this requires the insertion of a dummy instruction while the next instruction is fetched, it is a two cycle instruction. If the result is not 0, the program proceeds with the following instruction.
Operation	Skip if [m].i=0
Affected flag(s)	None
<b>TABRD [m]</b>	Read table (specific page or current page) to TBLH and Data Memory
Description	The low byte of the program code addressed by the table pointer (TBHP and TBLP or only TBLP if no TBHP) is moved to the specified Data Memory and the high byte moved to TBLH.
Operation	[m] ← program code (low byte) TBLH ← program code (high byte)
Affected flag(s)	None
<b>TABRDL [m]</b>	Read table (last page) to TBLH and Data Memory
Description	The low byte of the program code (last page) addressed by the table pointer (TBLP) is moved to the specified Data Memory and the high byte moved to TBLH.
Operation	[m] ← program code (low byte) TBLH ← program code (high byte)
Affected flag(s)	None
<b>XOR A,[m]</b>	Logical XOR Data Memory to ACC
Description	Data in the Accumulator and the specified Data Memory perform a bitwise logical XOR operation. The result is stored in the Accumulator.
Operation	ACC ← ACC "XOR" [m]
Affected flag(s)	Z

<b>XORM A,[m]</b>	Logical XOR ACC to Data Memory
Description	Data in the specified Data Memory and the Accumulator perform a bitwise logical XOR operation. The result is stored in the Data Memory.
Operation	$[m] \leftarrow \text{ACC} \text{ "XOR" } [m]$
Affected flag(s)	Z
<b>XOR A,x</b>	Logical XOR immediate data to ACC
Description	Data in the Accumulator and the specified immediate data perform a bitwise logical XOR operation. The result is stored in the Accumulator.
Operation	$\text{ACC} \leftarrow \text{ACC} \text{ "XOR" } x$
Affected flag(s)	Z

## Package Information

Note that the package information provided here is for consultation purposes only. As this information may be updated at regular intervals users are reminded to consult the [Holtek website](#) for the latest version of the [Package/Carton Information](#).

Additional supplementary information with regard to packaging is listed below. Click on the relevant section to be transferred to the relevant website page.

- Package Information (include Outline Dimensions, Product Tape and Reel Specifications)
- The Operation Instruction of Packing Materials
- Carton information

**24-pin SSOP (150mil) Outline Dimensions**

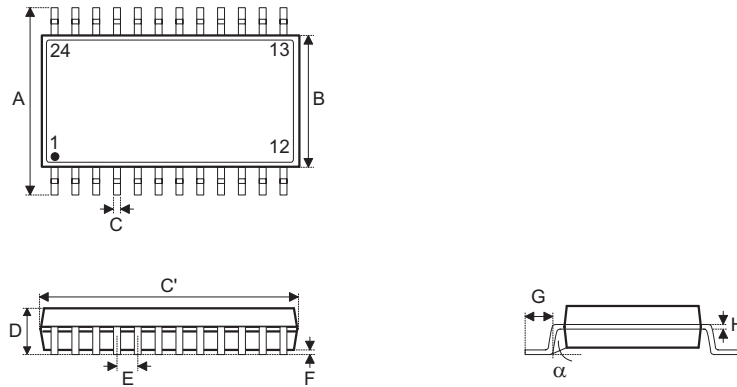

Symbol	Dimensions in inch		
	Min.	Nom.	Max.
A	0.236 BSC		
B	0.154 BSC		
C	0.008	—	0.012
C'	0.341 BSC		
D	—	—	0.069
E	0.025 BSC		
F	0.004	—	0.010
G	0.016	—	0.050
H	0.004	—	0.010
α	0°	—	8°

Symbol	Dimensions in mm		
	Min.	Nom.	Max.
A	6.00 BSC		
B	3.90 BSC		
C	0.20	—	0.30
C'	8.66 BSC		
D	—	—	1.75
E	0.635 BSC		
F	0.10	—	0.25
G	0.41	—	1.27
H	0.10	—	0.25
α	0°	—	8°

28-pin SSOP (150mil) Outline Dimensions

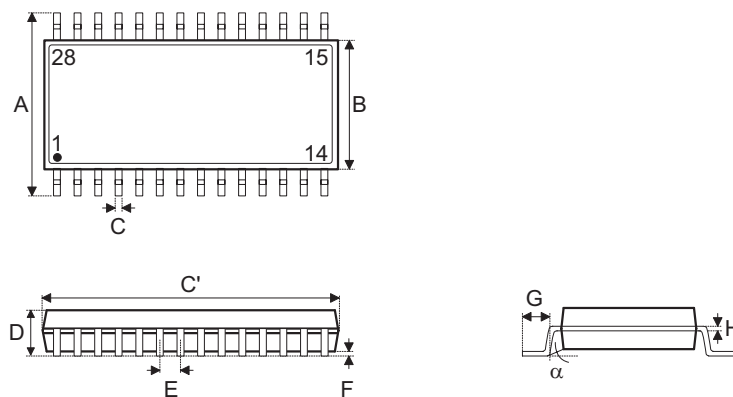

Symbol	Dimensions in inch		
	Min.	Nom.	Max.
A	0.236 BSC		
B	0.154 BSC		
C	0.008	—	0.012
C'	0.390 BSC		
D	—	—	0.069
E	0.025 BSC		
F	0.004	—	0.010
G	0.016	—	0.050
H	0.004	—	0.010
α	0°	—	8°

Symbol	Dimensions in mm		
	Min.	Nom.	Max.
A	6.00 BSC		
B	3.90 BSC		
C	0.20	—	0.30
C'	9.90 BSC		
D	—	—	1.75
E	0.635 BSC		
F	0.10	—	0.25
G	0.41	—	1.27
H	0.10	—	0.25
α	0°	—	8°

Copyright© 2025 by HOLTEK SEMICONDUCTOR INC. All Rights Reserved.

The information provided in this document has been produced with reasonable care and attention before publication, however, HOLTEK does not guarantee that the information is completely accurate. The information contained in this publication is provided for reference only and may be superseded by updates. HOLTEK disclaims any expressed, implied or statutory warranties, including but not limited to suitability for commercialization, satisfactory quality, specifications, characteristics, functions, fitness for a particular purpose, and non-infringement of any third-party's rights. HOLTEK disclaims all liability arising from the information and its application. In addition, HOLTEK does not recommend the use of HOLTEK's products where there is a risk of personal hazard due to malfunction or other reasons. HOLTEK hereby declares that it does not authorize the use of these products in life-saving, life-sustaining or safety critical components. Any use of HOLTEK's products in life-saving/sustaining or safety applications is entirely at the buyer's risk, and the buyer agrees to defend, indemnify and hold HOLTEK harmless from any damages, claims, suits, or expenses resulting from such use. The information provided in this document, including but not limited to the content, data, examples, materials, graphs, and trademarks, is the intellectual property of HOLTEK (and its licensors, where applicable) and is protected by copyright law and other intellectual property laws. No license, express or implied, to any intellectual property right, is granted by HOLTEK herein. HOLTEK reserves the right to revise the information described in the document at any time without prior notice. For the latest information, please contact us.