



DESCRIPTION

The SDD800 is composed of two distinct optically isolated optocouplers in one compact 8 PDIP package. Each optocoupler consists of a Photo Darlington transistor optically coupled to an AlGaAs LED. Optical coupling between the input LED and output Photo Darlington allows for high isolation levels while maintaining low-level DC signal control capability. The SDD800 provides an optically isolated method of controlling many interface applications such as telecommunications, industrial control and instrumentation circuitry.

FEATURES

- Two isolated optocouplers in one compact 8 pin DIP package
- High Load Voltage ($V_{ceo} = 300V$ MIN)
- High current transfer ratio (600-9000%)
- High input-to-output isolation package (5,000 Vrms)

OPTIONS/SUFFIXES*

- -H .04" (10.16mm) lead spacing (VDE0884)
- -S Surface Mount Option
- -TR Tape and Reel Option

NOTE: Suffixes listed above are not included in marking on device for part number identification.

SCHEMATIC DIAGRAM

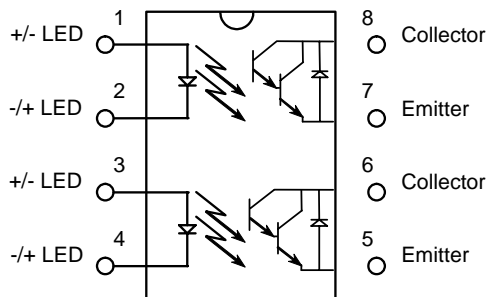

APPLICATIONS

- Home Appliances
- Office Automation Equipment
- Telecom / Datacom
- Power Supplies
- Fax / Modems

ABSOLUTE MAXIMUM RATINGS*

PARAMETER	UNIT	MIN	TYP	MAX
Storage Temperature	°C	-55		125
Operating Temperature	°C	-40		100
Continuous Forward Current	mA			50
Peak Forward Current	A			1
Reverse Voltage	V			6
Output Power Dissipation	mW			200

*The values indicated are absolute stress ratings. Functional operation of the device is not implied at these or any conditions in excess of those defined in electrical characteristics section of this document. Exposure to Absolute Ratings may cause permanent damage to the device and may adversely affect reliability.

APPROVALS

- UL / C-UL Approved, File # E201932
- VDE Approved, License # 40011227

ELECTRICAL CHARACTERISTICS - 25°C

PARAMETER	UNIT	MIN	TYP	MAX	TEST CONDITIONS
INPUT SPECIFICATIONS					
LED Forward Voltage	V		1.2	1.4	If = 20mA
Peak Forward Voltage	V			3.5	Ifm = 0.5A
Reverse Current	μ A			10	Vr = 4V
Terminal Capacitance	p F		30		V = 0, f = 1kHz
OUTPUT SPECIFICATIONS					
Collector-Emitter Breakdown Voltage	V	300			Ic = 10uA
Emitter-Collector Voltage	V	0.1			Ie = 10uA
Dark Current	μ A			1	Vce = 200V, If = 0
Floating Capacitance	p F		0.6	1	Vce = 0V, f = 1.0MHz
Saturation Voltage (Collector - Emitter)	V			1.5	If = 20mA, Ic = 5mA
Current Transfer Ratio	%	600		9000	If = 1mA, Vce = 2V
Rise Time	μ s		60		Ic = 20mA, Vce = 2V, RL = 100 ohms
Fall Time	μ s		50		Ic = 20mA, Vce = 2V, RL = 100 ohms
COUPLED SPECIFICATIONS					
Isolation Voltage	V	5000			T = 1 minute
Isolation Resistance	G Ω	50			DC 500V
Cut off Frequency	k H z		7		Ic = 2mA, Vcc = 5V, RL = 100 ohms

PERFORMANCE DATA

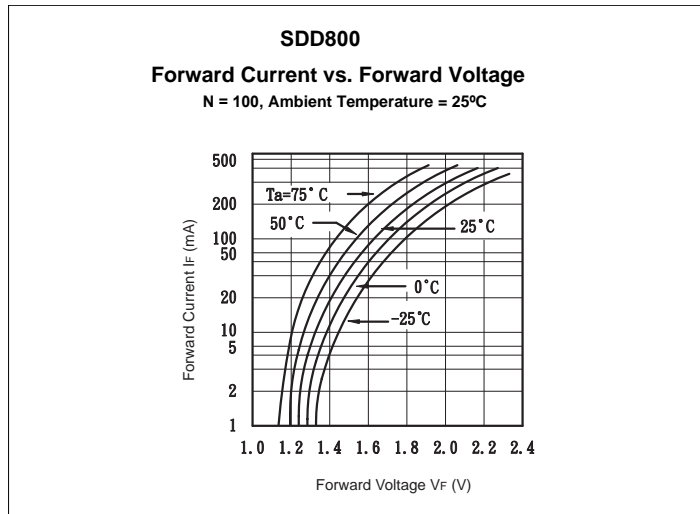
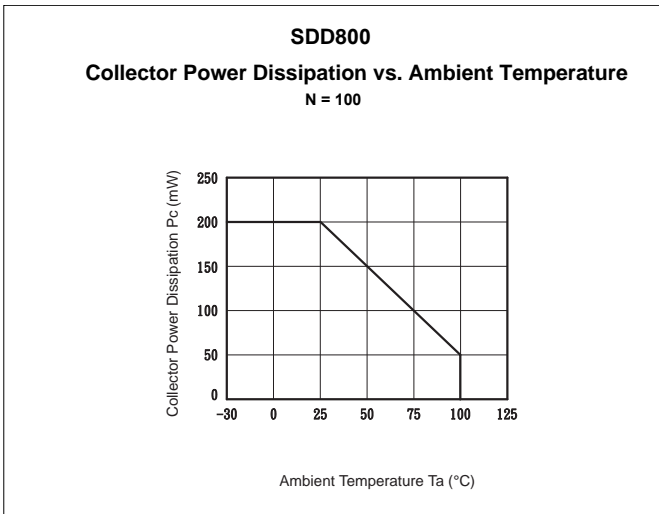
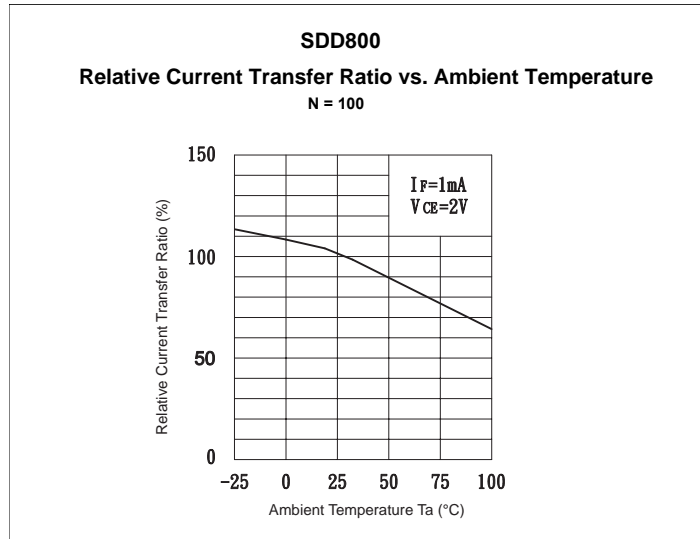
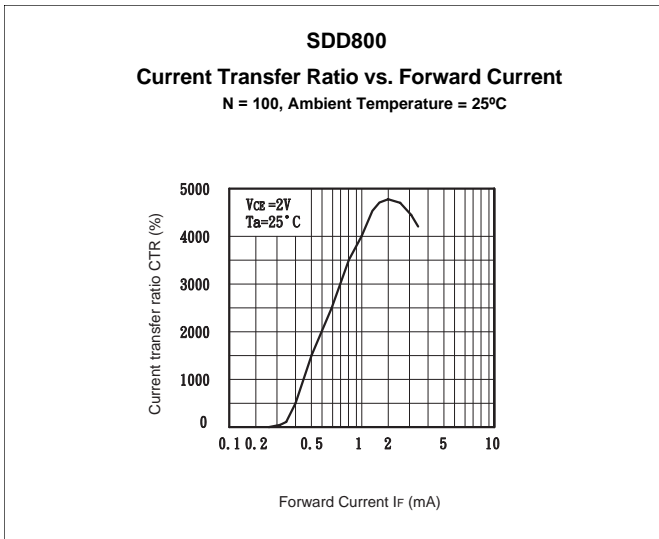
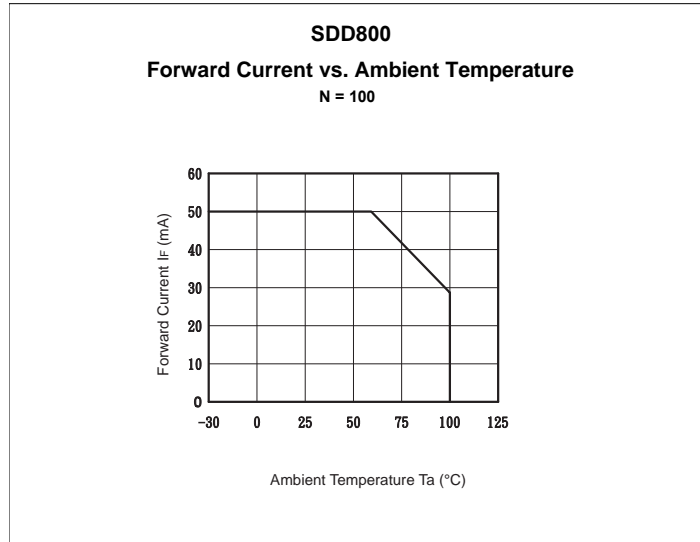
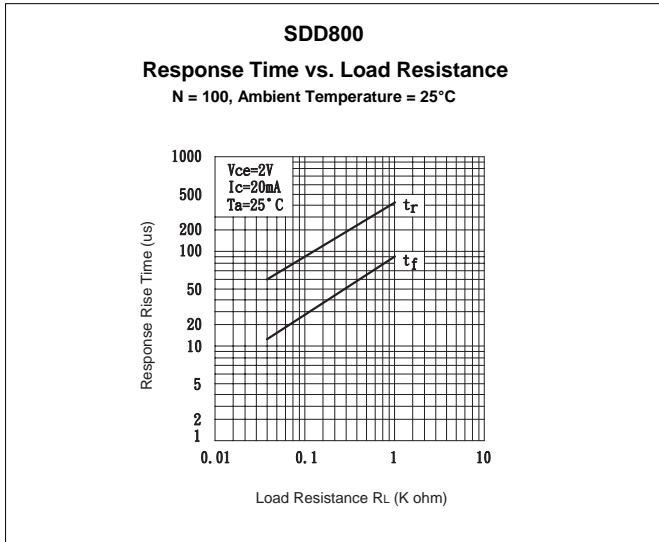

PERFORMANCE DATA

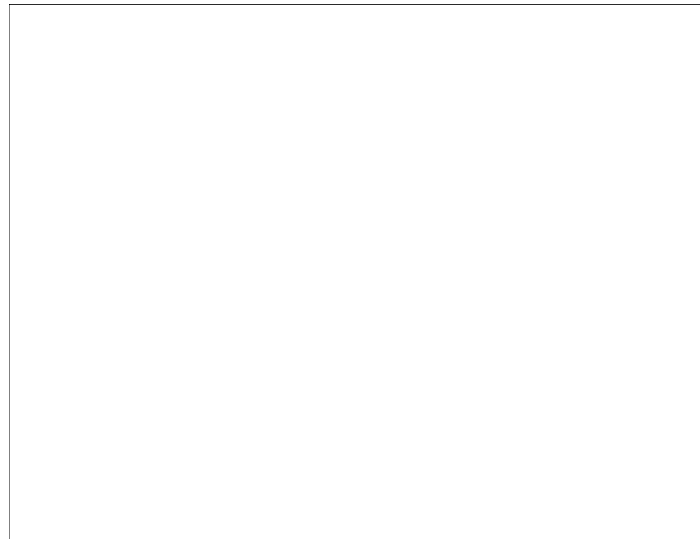
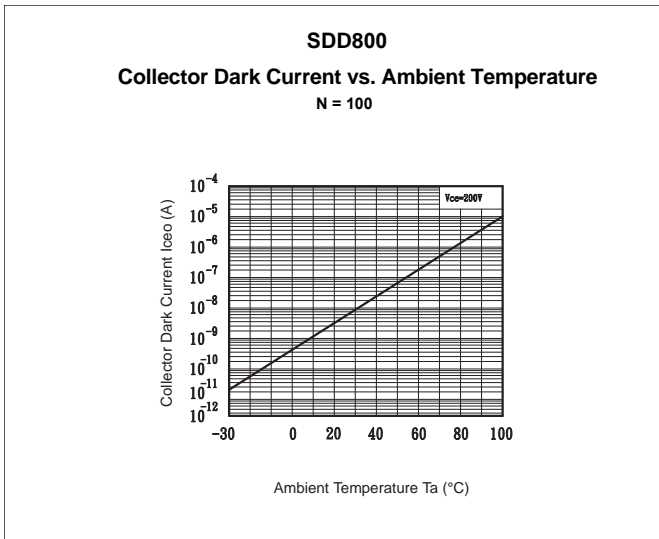
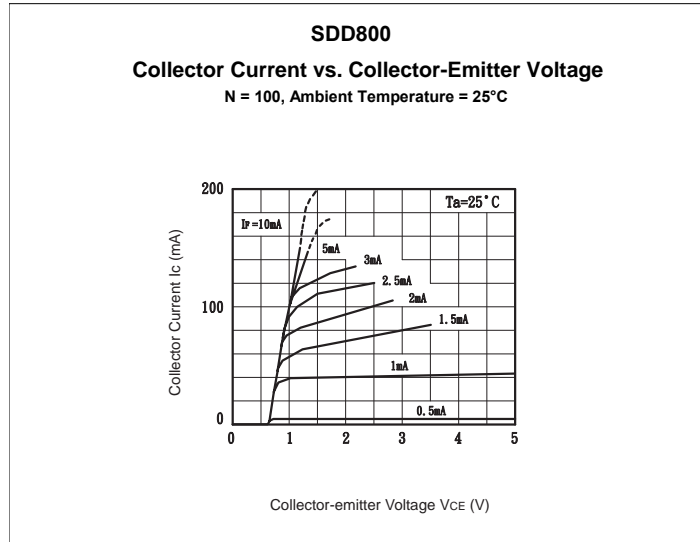
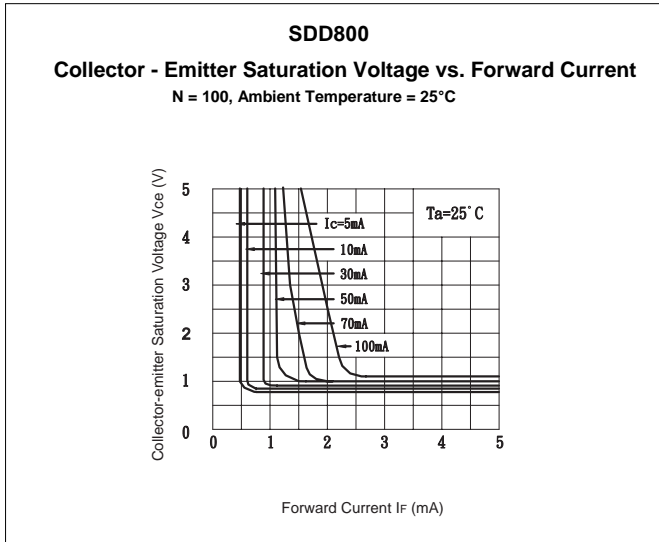

MECHANICAL DIMENSIONS

8 PIN DUAL IN-LINE PACKAGE

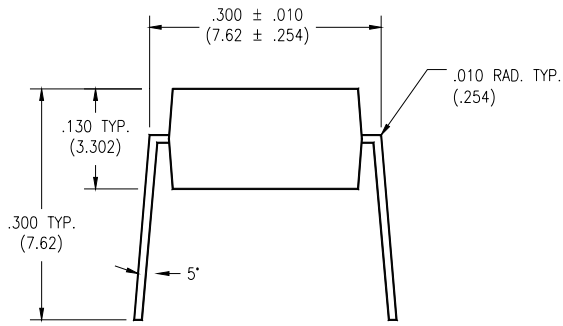

END VIEW

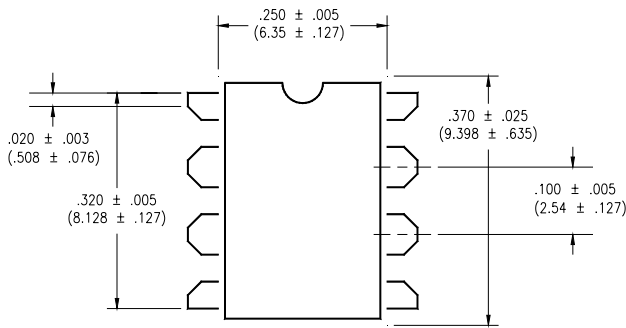

TOP VIEW

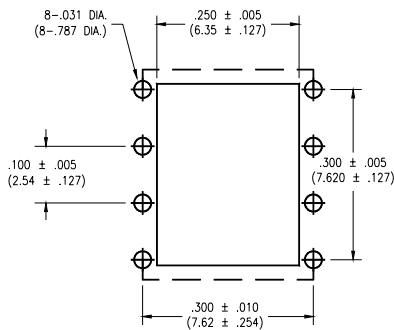

**BOTTOM VIEW/
BOARD PATTERN**

8 PIN SURFACE MOUNT DEVICE

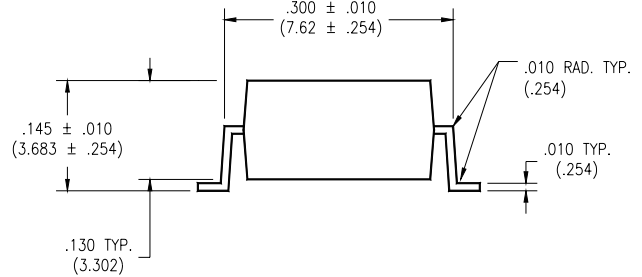

END VIEW

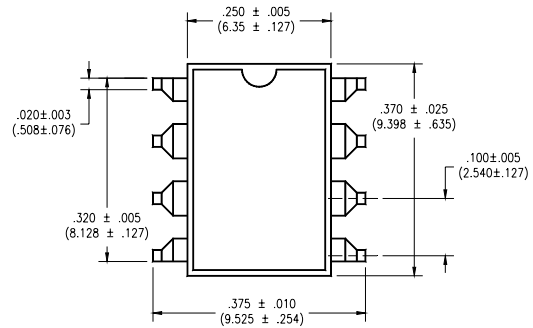

TOP VIEW

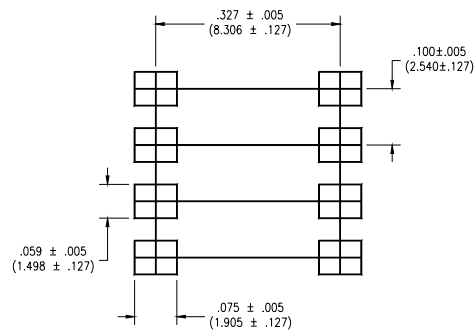

**BOTTOM VIEW/
BOARD PATTERN**

DISCLAIMER

Solid State Optronics (SSO) makes no warranties or representations with regards to the completeness and accuracy of this document. SSO reserves the right to make changes to product description, specifications at any time without further notice. SSO shall not assume any liability arising out of the application or use of any product or circuit described herein. Neither circuit patent licenses nor indemnity are expressed or implied. Except as specified in SSO's Standard Terms & Conditions, SSO disclaims liability for consequential or other damage, and we make no other warranty, expressed or implied, including merchantability and fitness for particular use.

LIFE SUPPORT POLICY

SSO does not authorize use of its devices in life support applications wherein failure or malfunction of a device may lead to personal injury or death. Users of SSO devices in life support applications assume all risks of such use and agree to indemnify SSO against any and all damages resulting from such use. Life support devices are defined as devices or systems which, (a) are intended for surgical implant into the body, or (b) support or sustain life, and (c) whose failure to perform when used properly in accordance with instructions for use can be reasonably expected to result in significant injury to the user, or (d) a critical component in any component of a life support device or system whose failure can be reasonably expected to cause failure of the life support device or system, or to affect its safety or effectiveness.