

## VKL144D

- Operating voltage:2.4-5.5V
- Built-in 32kHz RC oscillator
- Selection of 1/2 or 1/3 bias
- 1/4duty(4COM)
- Built-in 36x4 bits display RAM
- Selection of 80Hz、 71Hz、 64Hz、 53Hz Frame Frequency
- STANDBY mode (by System Set Command LCD OFF)
- Four power consumption modes can be configured
- I2C bus interface
- Display mode 36x4
- Versatile blinking modes
- Software configuration LCD parameters
- Read/Write address auto increment
- VLCD pin for adjusting LCD operating voltage( $\leq (VDD-VLCD)$ )
- Built-in power on reset circuit (POR) - TEST2 =0 enable
- Low power consumption、 High anti-interference
- Package:  
SSOP48(300mil)(15.9mm x 7.5mm PP=0.635mm)

## 1 General Description

VKL144D is a RAM Mapping LCD Driver, It can support LCD screens with a maximum of 144 pattern(36SEGx4COM) .The device communicates with host microcontrollers via a two-line bidirectional I2C bus,it is used to configure display parameters and transfer display data, , and can also enter the standby mode through System Set Command .Four power consumption modes can be configured.With the characteristics of high anti-interference and low power consumption, it is suitable for water electrical meters and industrial control instruments.

## 2 Pinouts and pin description

### 2.1 VKL144D SSOP48 Pin Assignment

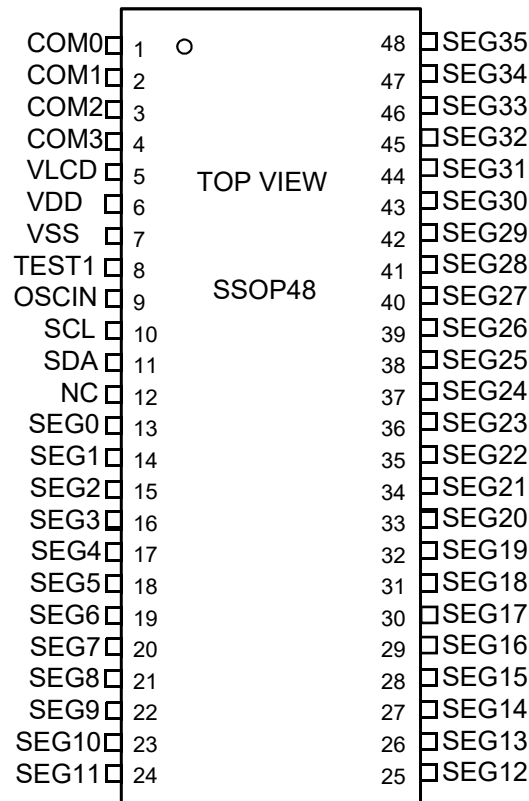

## 2.2 VKL144D SSOP48Pin Description

No.	Name	I/O	Function
1-4	COM0-COM3	O	LCD COM outputs
5	VLCD	I	LCD power input=(VDD-VLCD)
6	VDD	VDD	Positive power supply
7	VSS	VSS	Negative power supply
8	TEST1	I	TEST pin must be connect to VSS
9	OSCIN	I	External clock input pin. The software configures whether to use external clock or built-in RC oscillator. When using internal oscillator, this pin must be connect to VSS
10	SCL	I	Serial Clock Input for I2C interface
11	SDA	I/O	Serial Data Input/Output for I2C interface
12	NC	—	—
13-48	SEG0-SEG30	O	LCD SEG outputs

## 3 Functional Description

### 3.1 Block diagram

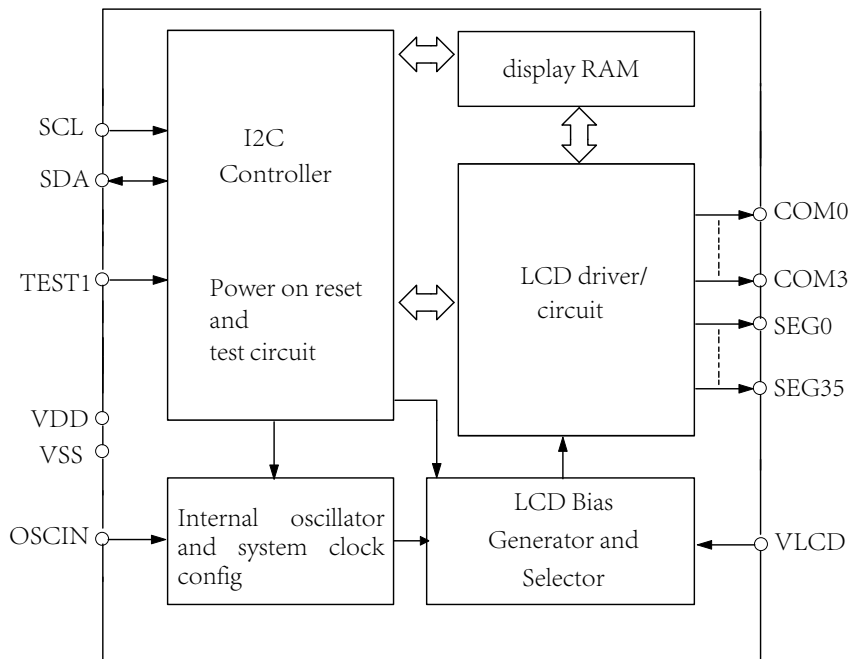

## 3.2 Display RAM

The static display memory (RAM) is organized into  $36 \times 4$  bits and stores the displayed data. The contents of the RAM are directly mapped to the contents of the LCD driver. Data in the RAM can be accessed by the I2C bus interface.

The following is a mapping from the RAM to the LCD pattern:

OUTPUT	COM3	COM2	COM1	COM0	ADDR	OUTPUT	COM3	COM2	COM1	COM0	ADDRESS
SEG1	h	g	f	e	0x01	SEG0	d	c	b	a	0x00
SEG3	p	o	n	m	0x03	SEG2	l	k	j	i	0x02
SEG5					0x05	SEG4					0x04
SEG7					0x07	SEG6					0x06
SEG9					0x09	SEG8					0x08
SEG11					0x0B	SEG10					0x0A
⋮	⋮	⋮	⋮	⋮	⋮	⋮	⋮	⋮	⋮	⋮	⋮
SEG35					0x23	SEG34					0x22
<b>Data</b>	bit7	bit6	bit5	bit4			bit3	bit2	bit1	bit0	

RAM Mapping of  $36 \times 4$

For example, display data seg0-seg3 shown in the table above and the data a-p written to the display RAM is as follows:

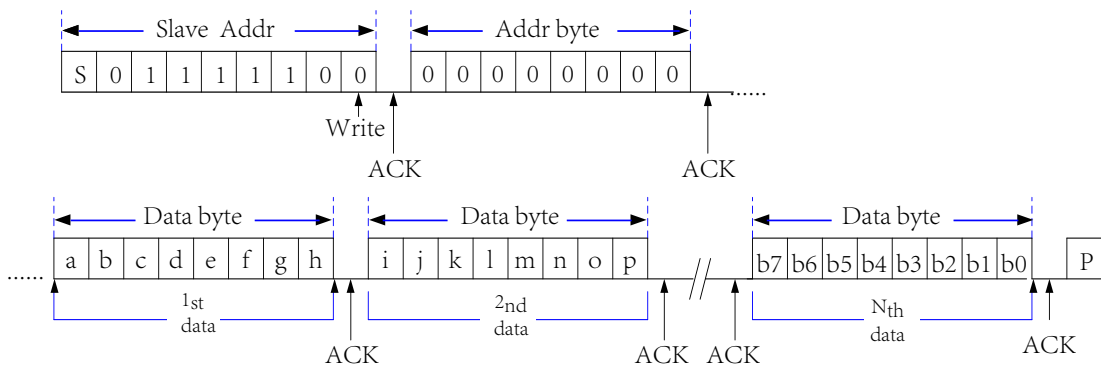

### 3.3 System Oscillator

The timing for the internal logic and the LCD drive signals are generated by an internal oscillator(32kHz) or an external clock source(OSCIN). The system clock frequency ( $f_{SYS}$ ) determines the LCD frame frequency.

System Oscillator Configuration:

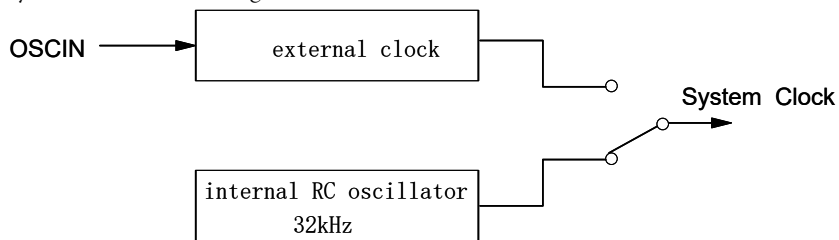

### 3.4 LCD operating voltage

It can be obtained through VLCD pin (connected a resistor to VSS pin), LCD operating voltage =  $V_{DD} - V_{LCD}$ , and built-in op amplifier to realize low-power driving.

VR is used to adjust the contrast, use  $1M\Omega$  resistor to adjust to the best display effect, and take the resistance value at this time.

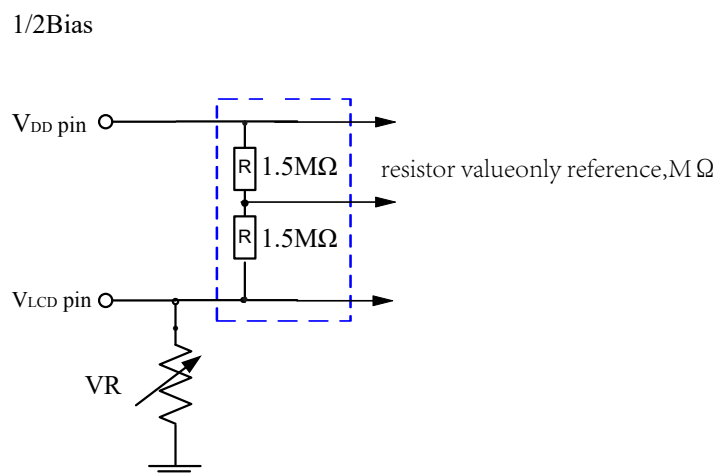
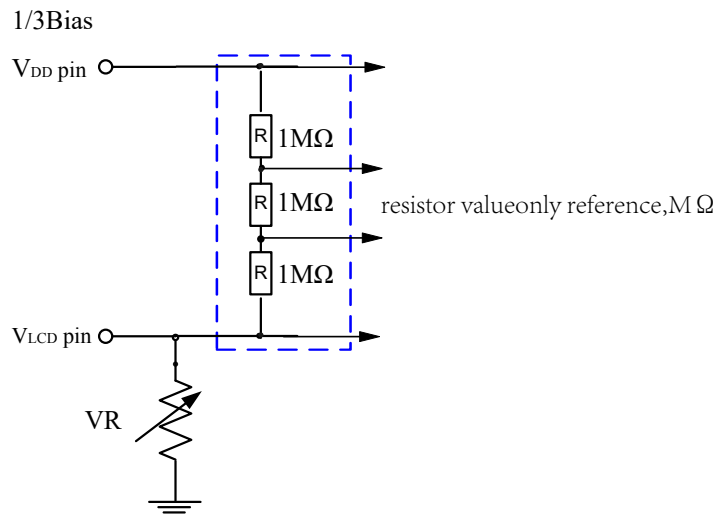

### 3.5 Power-On Reset

When the power is applied, the device is initialized by an internal power-on reset circuit. Data transfers on the I2C bus should be avoided for 1 ms following power-on.

The status of the internal circuits after initialization is as follows:

- All COM/SEG outputs are set to VDD
- 1/4 duty and 1/3 bias.
- The System Oscillator and the LCD bias generator are off state
- LCD Display is off state.
- Blinking function is switched off..

When powered on, NC pin is low-level enabling POR.

if VDD drops below the minimum voltage of operating voltage specification during operation, the power-on reset timing conditions must be also satisfied. This means that VDD must fall to 0V and remain at 0V for a minimum time of 100ms before rising to the normal operating voltage.

Power-on Reset Timing

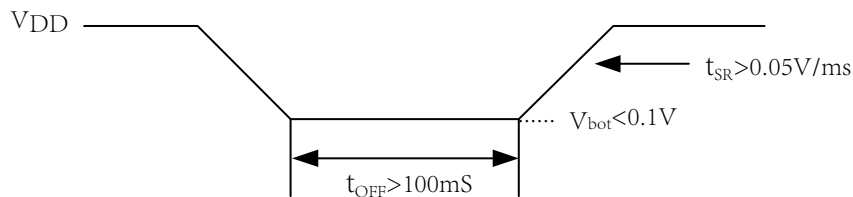

When power on, NC pin is high-level and POR is disable. In order to make the internal circuit in the reset state, it must be configured as follows:

- I. The stop condition is that when SCL = h, SDA changes from L to H
- II. Set soft reset in System set command (bit1=1)

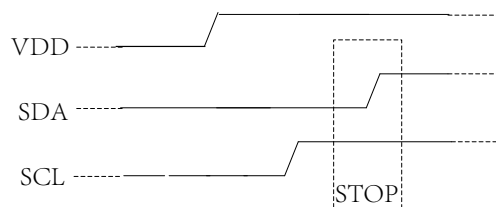

### 3.6 LCD Communication Command

The display modes supported by the LCD driver are 36SEG x 4COM, The unused SEG or COM outputs should be left open. The frame frequency can be configured as 4 frequencies, and the default is 80Hz when powered on.

Configure display parameters and read / write display data through I2C interface.

#### 3.6.1 I2C Serial Interface

The device supports I2C serial interface.

The two lines are a serial data line, SDA, and a serial clock line, SCL. Both lines are connected to the positive supply via pull-up resistors with a typical value of 4.7k. When the bus is free, both lines are high.

**START and STOP**

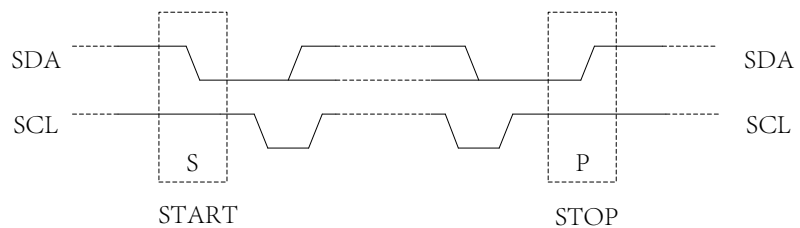

**Byte Format**

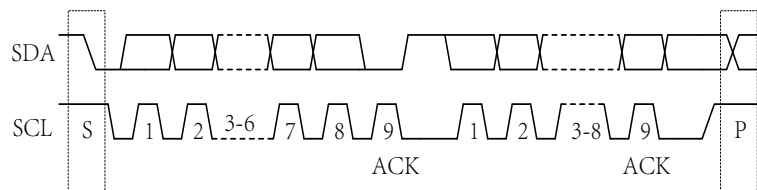

**Acknowledge**

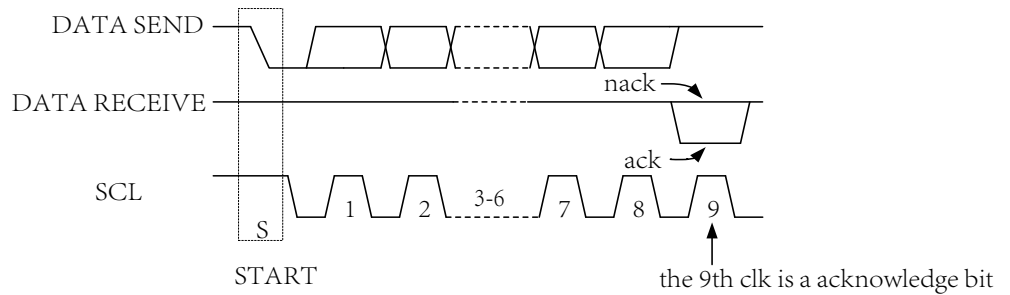

**Slave Address**

( 0x7c) bit0-R/W

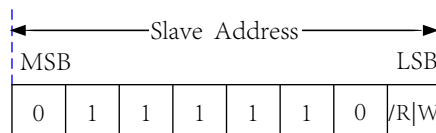

### 3.6.2 I2C Command Format

#### Write Operation

##### Write command

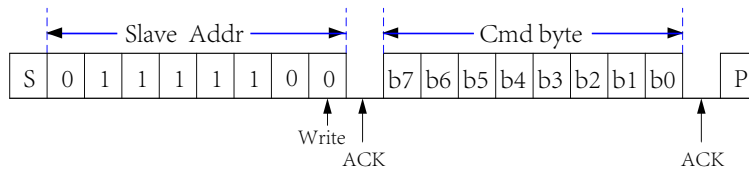

##### Display RAM Single Data Byte

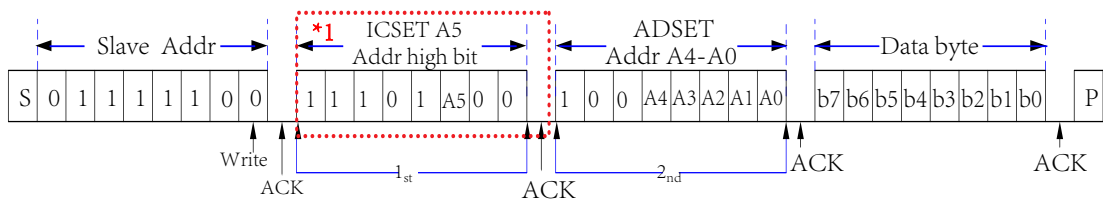

##### Display RAM Page Write Operation

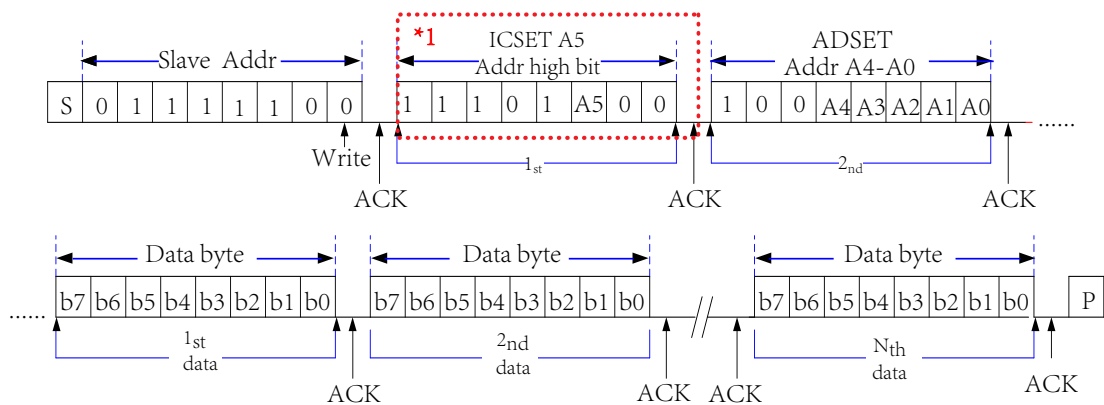

#### Read Operation

##### Display RAM Page Read Operation

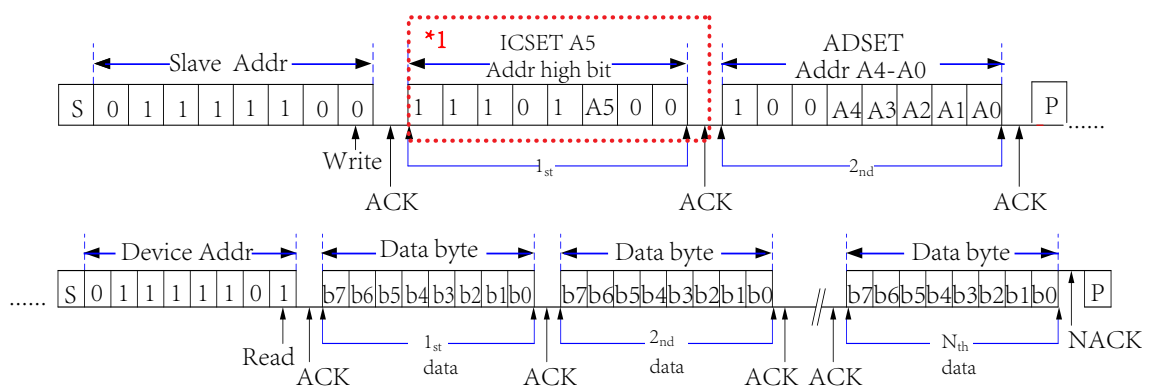

Note: \*1 bit2-A5 This byte can not be sent when A5 = 0

### 3.6.3 Command Description

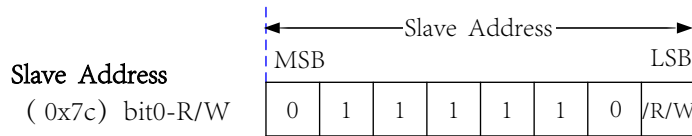

bit7 next byte is data (D) or command(C):  
 bit7=0 next byte is data, bit7=1 next byte is command

#### 3.6.3.1 Mode Set Command

Set working mode:

function	byte	Bit 7	Bit 6	Bit 5	Bit 4	Bit 3	Bit 2	Bit 1	Bit 0	Note	R/W	Def
Address pointer	1	C/D	1	0	X	E	M0	X	X		W	

Bit 3	
E	LCD On/Off
0	OFF (Def)
1	ON

Bit 2	
M0	BIAS
0	1/3 bias (Def)
1	1/2 bias

#### 3.6.3.2 System Set Command

Select the internal system oscillator external clock and set soft reset.

function	byte	Bit 7	Bit 6	Bit 5	Bit 4	Bit 3	Bit 2	Bit 1	Bit 0	Note	R/W	Def
Address pointer	1	C/D	1	1	0	1	A5	R	CLKS		W	

Bit 2	
A5	display adress bit5
0	0 (Def)
1	1

Bit 1	
R	soft reset
0	--- (Def)
1	soft reset

Bit 0	
CLKS	System clock source
0	internal oscillator (Def)
1	external clock OSCIN

note:

1. When internal RC oscillator is selected, OSCIN pin connect to VSS.
2. A5 is display address bit5,

### 3.6.3.3 Address Set Command

Display start address set:

function	byte	Bit 7	Bit 6	Bit 5	Bit 4	Bit 3	Bit 2	Bit 1	Bit 0	Note	R/W	Def
address pointer	1	C/D	0	0	A4	A3	A2	A1	A0		W	

A5	Bit4-0	Display address
	A4-A0	
0	00000	0x00 (Def)
0	00001	0x01
0	00010	0x02
.....	.....	.....
0	11111	0x1f
1	00000	0x10
1	00001	0x11
1	00010	0x12
1	00011	0x13

Note: A5 is display address bit5, refer to the System Set Command bit2

### 3.6.3.4 All Pixel On /Off Command

LCD All Pixel On /Off set:

function	byte	Bit 7	Bit 6	Bit 5	Bit 4	Bit 3	Bit 2	Bit 1	Bit 0	Note	R/W	Def
Address pointer	1	C/D	1	1	1	1	1	AP1	AP0		W	

Bit 1	Bit 0	All Pixel On /Off
AP1	AP0	
0	0	Normal (Def)
0	1	All Pixel Off
1	0	All Pixel On
1	1	All Pixel Off

Note:

- 1.This command does not affect the content display of RAM
- 2.This command is valid only when the LCD ON

### 3.6.3.5 Blinking Frequency Command

Set the blinking frequency

function	byte	Bit 7	Bit 6	Bit 5	Bit 4	Bit 3	Bit 2	Bit 1	Bit 0	Note	R/W	Def
blinking freq set	1	C/D	1	1	1	0	0	BK1	BK0		W	

Bit 1	Bit 0	blinking freq
BK1	BK0	
0	0	blinking off <b>(Def)</b>
0	1	0.5Hz
1	0	1Hz
1	1	2Hz

### 3.6.3.6 Display Control Command

Set LCD Driver Mode, Frame Frequency and 4 Power Modes

function	byte	Bit 7	Bit 6	Bit 5	Bit 4	Bit 3	Bit 2	Bit 1	Bit 0	Note	R/W	Def
Display Control set	1	C/D	0	1	FR1	FR0	DM	SR1	SR0		W	

Bit 4	Bit 3	Frame Frequency	Bit 2	Driver Mode
FR1	FR0		DM	
0	0	80Hz <b>(Def)</b>	0	Line Flip <b>(Def)</b>
0	1	71Hz	1	Frame Flip
1	0	64Hz		
1	1	53Hz		

Bit 1	Bit 0	Power Modes	Power Diss
SR1	SR0		
0	0	low power mode1 (LP1)	x0.5
0	1	low power mode2 (LP2)	0.67
1	0	normal (NP) <b>(Def)</b>	1.0
1	1	high power mode(HP)	1.8

Operating current :

1. 80Hz>71Hz>64Hz>53Hz
2. Line Flip>Frame Flip
3. high power>normal>low power mode2>low power mode1
4. power consumption data is only for reference and is also related to the LCD used

Different display control commands have different display effects, as shown in the following table:

display control	tremble	Display effect/contrast
frame freq	V	---
drive mode	V	V
power mode	---	V
The impact is not absolute, but also related to the LCD used.		

## 4 Command application

### 4.1 Start Sequence

During power on, the power on reset sequence shall be met. After power on, the parameters shall be configured first.

Config parameters through a series of commands. The command sequence is as follows:

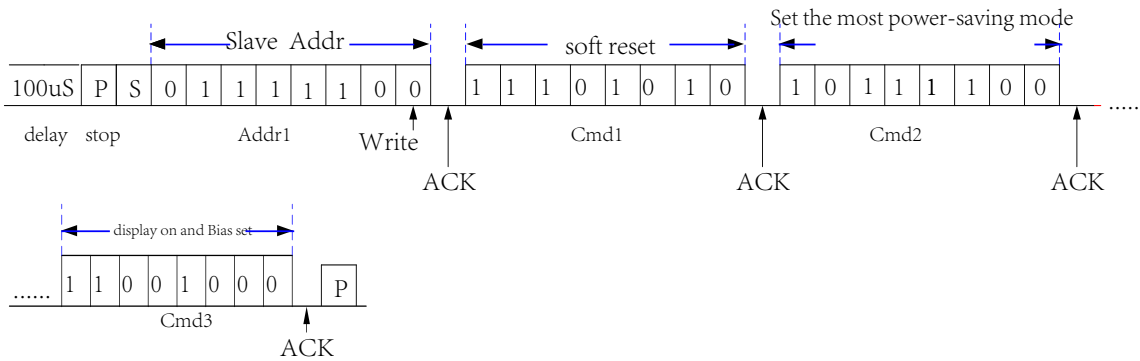

power on:	power sequence
delay:	Delay 100uS for chip initialization
STOP:	Send I2C stop signal
START:	Send I2C start signal
Addr1:	Send slave address (0x7c)
Cmd1:	System Set Cmd -SOFT reset (0xEA)
Cmd2:	Display Control Cmd -For example, set to the most power-saving mode (0xBC)
Cmd3:	Mode Set Command -display on and bias set.For example, 1/3bias display on (0xC8)
STOP	Send I2C stop signal

## 4.2 Display Control Command

The display control has been configured during initialization and does not need blinking. Only display data need to be sent.

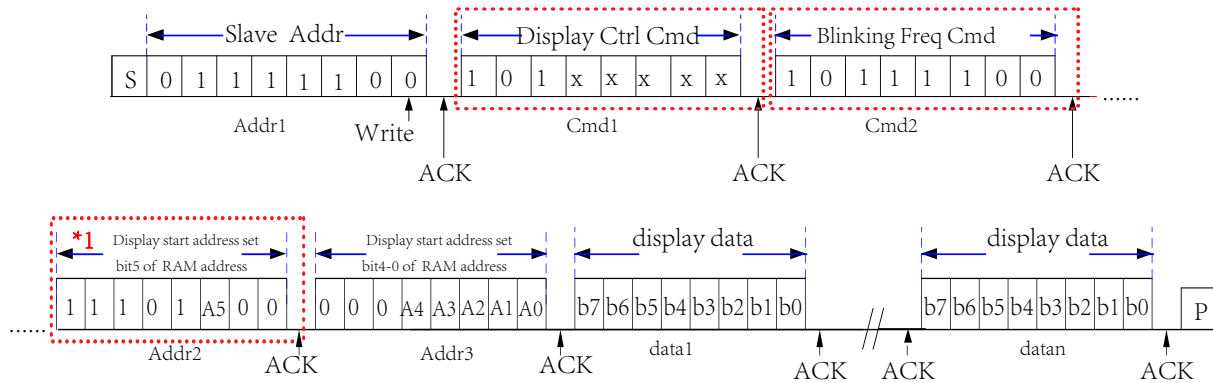

Note: \*1 bit2-A5 This byte can not be sent when A5 = 0

- START: Send I2C start signal
- Addr1: Send slave address (0x7c)
- Cmd1: Display Ctrl Cmd - do not need to send this byte when the display configuration has not changed
- Cmd2: Blanking Freq Cmd - blink does not need and this byte does not need to be sent
- Addr2-Addr3: Address Set Cmd - Display start address set (0xE8, 0x00)
- Data1-Datan: Send the display data to the set start address of the RAM and its subsequent address (up to 18 bytes)
- STOP: Send I2C stop signal

### 4.3 Display Off

Other commands can also refer to this format.

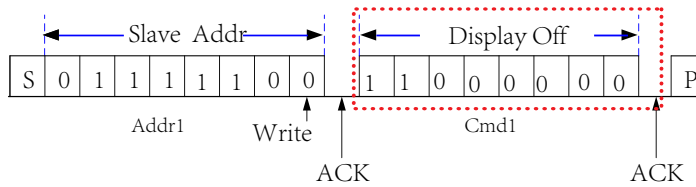

START: Send I2C start signal

Addr1: Send slave address (0x7c)

Cmd1: Mode set command -Display Off (0xC0)

STOP: Send I2C stop signal

## 5 Application Circuits

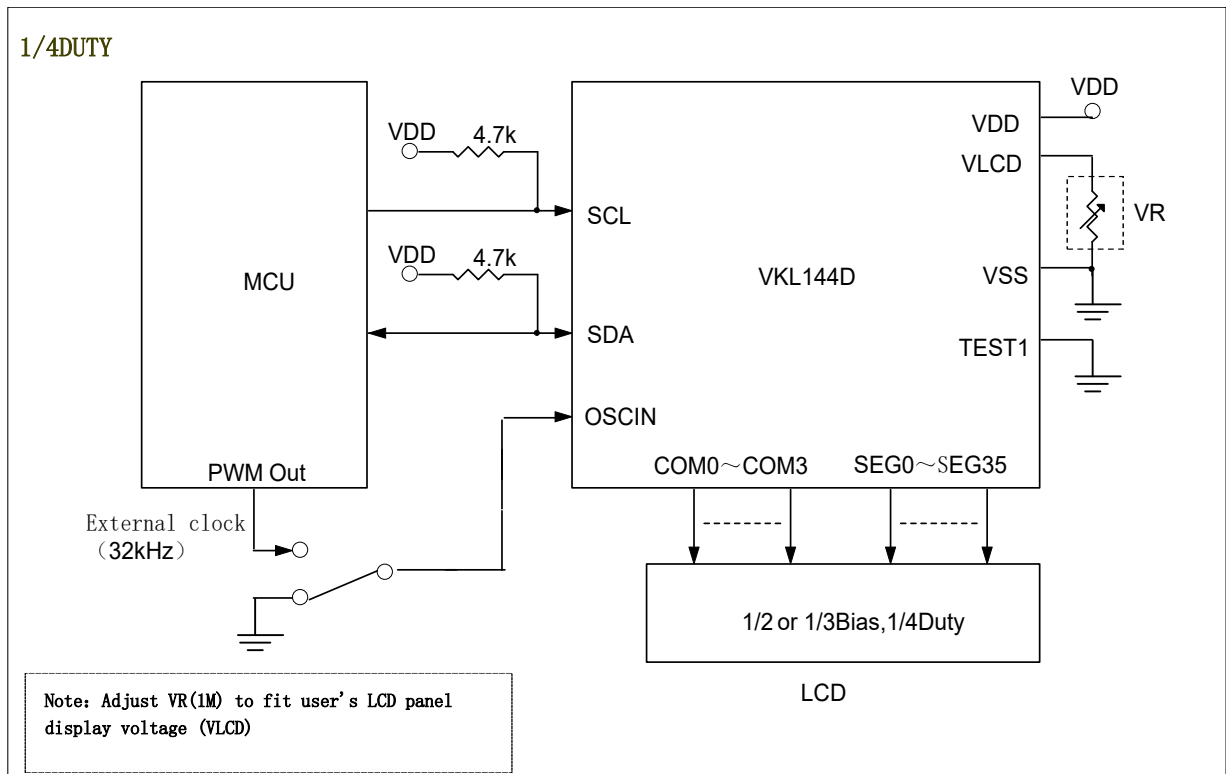

## 6 Electrical characteristics

### 6.1 Absolute Maximum Ratings

Item	Symbol	Ratings	Unit
Power voltage	VDD	-0.3~6.5	V
Input Voltage	VIN	$V_{SS}-0.3 \sim V_{DD}+0.3$	V
Storage Temperature	TSTG	-50~+125	°C
Operating Temperature	TOTG	-40~+85	°C

### 6.2 DC Characteristics

Item	Symbol	Min.	Typ.	Max.	Unit	Test Conditions	
						VDD	Conditions
Operating voltage	VDD	2.5	—	5.5	V	—	—
Operating current	I <sub>DD1</sub>	—	7.5	20	μA	3V	VDD=3.3V, 25°C, 1/3bias, power save model (LP1), frame freq 80Hz, FRAME flip
Standby Current	I <sub>STB</sub>	—	0.5	5	μA	3V	LCD off, Internal osc off
VLCD pin voltage *1	VLCD	0	—	VDD-2.4	V	3V	VDD-VLCD>=2.5V
Input Low Voltage	V <sub>IL</sub>	0	—	0.3	VDD	3V 5V	SCL, SDA
Input High Voltage	V <sub>IH</sub>	0.7	—	1.0	VDD	3V 5V	SCL, SDA
Low Level input Current	I <sub>IL</sub>	-1	—	—	μA	3V	---
High Level input Current	I <sub>IH</sub>	—	—	1	μA	3V	---
LCD ON resistor	R <sub>ON</sub>	—	3	—	kΩ	3V	I <sub>load</sub> =±10uA

\*1 LCD voltage=VDD-VLCD

## 6.3 AC Characteristics

### Frame Frequency

Item	Symbol	Min.	Typ.	Max.	Unit	Test Conditions	
						VDD	Conditions
LCD Frame Frequency	$f_{LCD1}$	56	80	104	Hz	3.3V	80Hz, -40 ~ +85 °C
LCD Frame Frequency	$f_{LCD2}$	49	71	93	Hz	3.3V	71Hz, -40 ~ +85 °C
LCD Frame Frequency	$f_{LCD3}$	44	64	84	Hz	3.3V	64Hz, -40 ~ +85 °C
LCD Frame Frequency	$f_{LCD4}$	37	53	69	Hz	3.3V	53Hz, -40 ~ +85 °C

### I2C parameter

Item	Symbol	Min.	Typ.	Max.	Unit	Test Conditions	
						VDD	Conditions
Clock Frequency	$f_{SCL}$	—	—	400	kHz	3.0-5.5V	—
Bus Free Time	$t_{BUF}$	1.3	—	—	μs	3.0-5.5V	Time in which the bus must be free before a new transmission can start
Start Condition Hold Time	$t_{HD:STA}$	0.6	—	—	μs	3.0-5.5V	After this period, the first clock pulse is generated
SCL Low Time	$t_{LOW}$	1.3	—	—	μs	3.0-5.5V	—
SCL High Time	$t_{HIGH}$	0.6	—	—	μs	3.0-5.5V	—
Start Condition Setup Time	$t_{SU:STA}$	0.6	—	—	μs	3.0-5.5V	Only relevant for repeated START condition
Data Hold Time	$t_{HD:DAT}$	0	—	—	ns	3.0-5.5V	—
Data Setup Time	$t_{SU:DAT}$	100	—	—	ns	3.0-5.5V	—
SDA and SCL Rising Time	$t_R$	—	—	0.3	μs	3.0-5.5V	periodically sampled
SDA and SCL Falling Time	$t_F$	—	—	0.3	μs	3.0-5.5V	periodically sampled
Stop Condition Setup Time	$t_{SU:STO}$	0.6	—	—	μs	3.0-5.5V	—
Output Valid from Clock	$t_{AA}$	—	—	0.9	μs	3.0-5.5V	—
Input Filter Time Constant (SDA and SCL pin)	$t_{SP}$	—	—	50	ns	3.0-5.5V	Noise suppression time

### I<sup>2</sup>C Timing

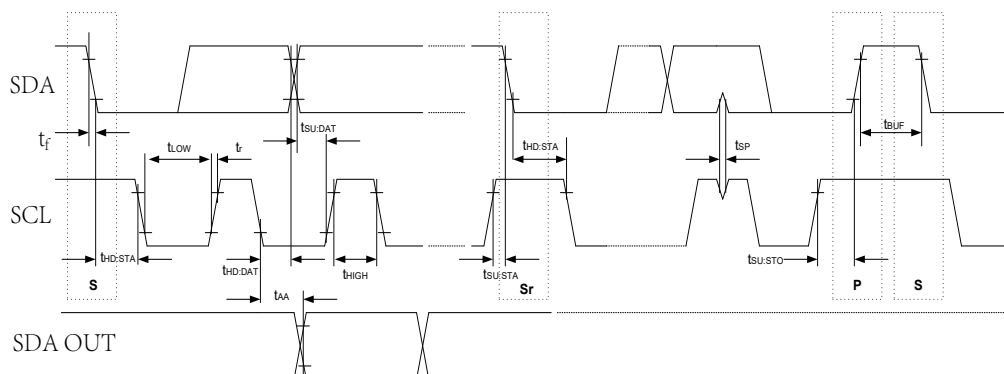

## 7 Package Information

### 7.1 SSOP48 (300mil) (15.9mm x 7.5mm PP=0.635mm)

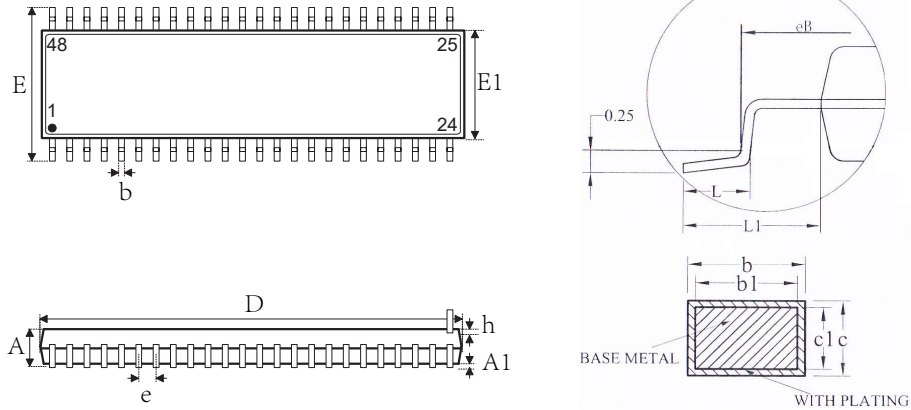

SYMBOL	MILLIMETER		
	MIN	NOM	MAX
A	--	--	2.80
A1	0.20	0.30	0.40
b	0.24	--	0.33
b1	0.23	0.25	0.28
c	0.14	--	0.23
c1	0.13	0.15	0.18
D	15.80	15.90	16.00
E	10.10	10.30	10.50
E1	7.40	7.50	7.60
e	0.635BSC		
h	0.30	--	0.50
L	0.61	--	0.91
L1	1.40REF		

## 8 Revision history

No.	Version	Date	Modify the content	Check
1	1.0	2018-08-10	Original version	Yes
2	1.1	2018-10-11	Add Ref circuits	Yes
3	1.2	2019-03-21	Check para	Yes
4	1.3	2020-04-11	Update content	Yes

### Disclaimers

Information in this document is believed to be accurate and reliable. However, VinKa does not give any representations or warranties, expressed or implied, as to the accuracy or completeness of such information. VinKa reserves the right to make changes to information published in this document, including without limitation specifications and product descriptions, at any time and without notice. This document supersedes and replaces all information supplied prior to the publication hereof. For the latest information, please visit <https://www.szvinka.com> Or contact VinKa's staff.